

RECOMMENDED PANEL MOUNTING

PANEL THICKNESS	X
0.75-1.25	30.0-30.2
1.25-2.00	30.2-30.4
2.00-3.00	30.6-30.8

SWITCH FUNCTION		
POS. 1	POS. 2	POS. 3
OFF	NONE	ON
OPEN	N/A	1-1a 2-2a

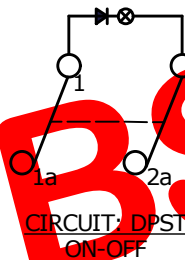

GRAPHICS: WHITE

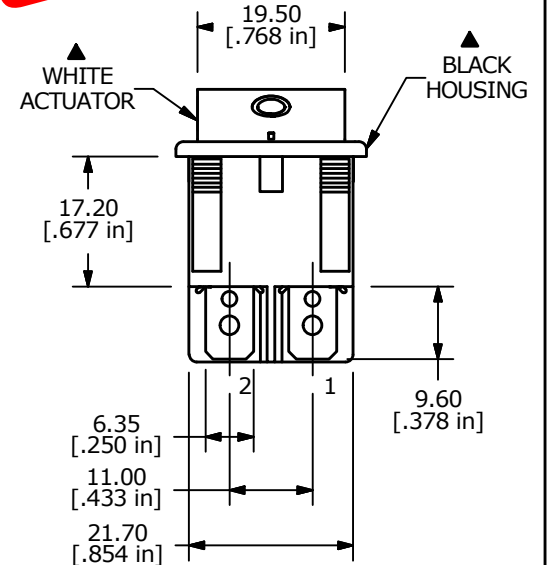
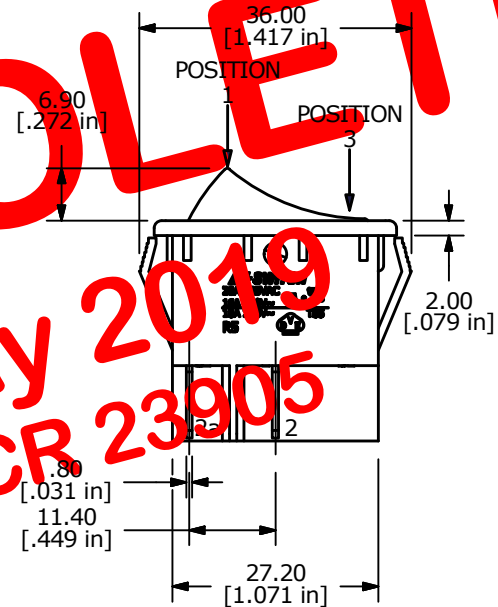
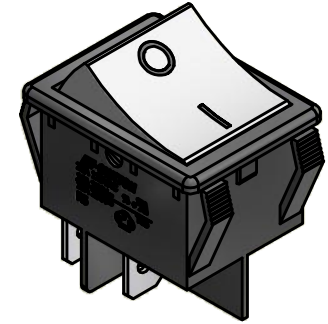
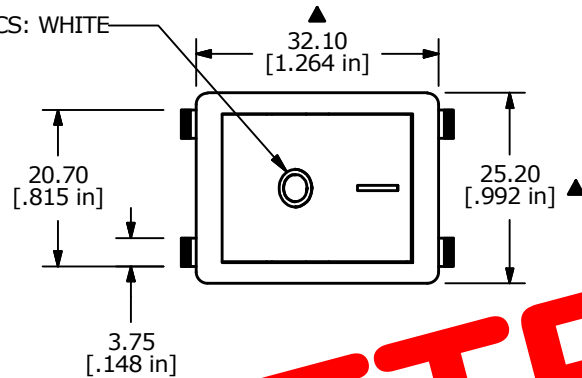

OBSOLETE
 May 2019
 PCR 23905

NOTES:

1. ALL DIMENSIONS IN MM [INCH]
2. GENERAL TOLERANCE: X.X=±0.4
X.XX=±0.25
3. TERM. NOS. FOR REF. ONLY
- ▲ 4. RATING: 20A @125VAC 3/4 HP UL APPROVED
16A @250VAC 1 HP UL APPROVED
16A @ 250VAC 1 HP VDE APPROVED
5. ELECTRICAL LIFE: 10,000 CYCLES
6. MECHANICAL LIFE: 30,000 CYCLES
7. CONTACT RESISTANCE: <20 MILLI-OHMS INITIAL
8. DIELECTRIC STRENGTH: >1,500V AC 1MIN
9. INSULATION RESISTANCE: >1000MOHMS
10. OPERATING TEMP: TERMINAL SIDE: -20°C to 85°C
ROCKER SIDE: -20°C to 55°C
- ▲ 11. LAMP: NEON 125V AC
12. ▲ DENOTES CRITICAL PARAMETER.
13. 2002/95/EC (ROHS) COMPLIANT



C	20124	ADD HP RATING	08/31/11	BMA
B	19771	UPDATE / CONVERT TO INVENTOR	03/21/11	BMA
REV	PCR NO	DESCRIPTION	DATE	BY

TITLE R5BBLKWHTFF1				
SCALE	DATE	DR	DWG	REV
1:1	3/21/2011	BA	M050230	C

THE INFORMATION CONTAINED IN THIS DOCUMENT IS PROPRIETARY TO E-SWITCH AND IS NOT TO BE COPIED OR TRANSFERRED