

EWCAP PIN	OPTION	MATING CONNECTOR COLOR
999-S-016-2-H01	H	YELLOW
999-S-016-2-G01	G	YELLOW
999-S-016-2-F01	F	YELLOW
999-S-016-2-E01	E	YELLOW
999-S-016-2-D01	D	BLACK
999-S-016-2-C01	C	DARK GREY
999-S-016-2-B01	B	GREY
999-S-016-2-A01	A	BLACK

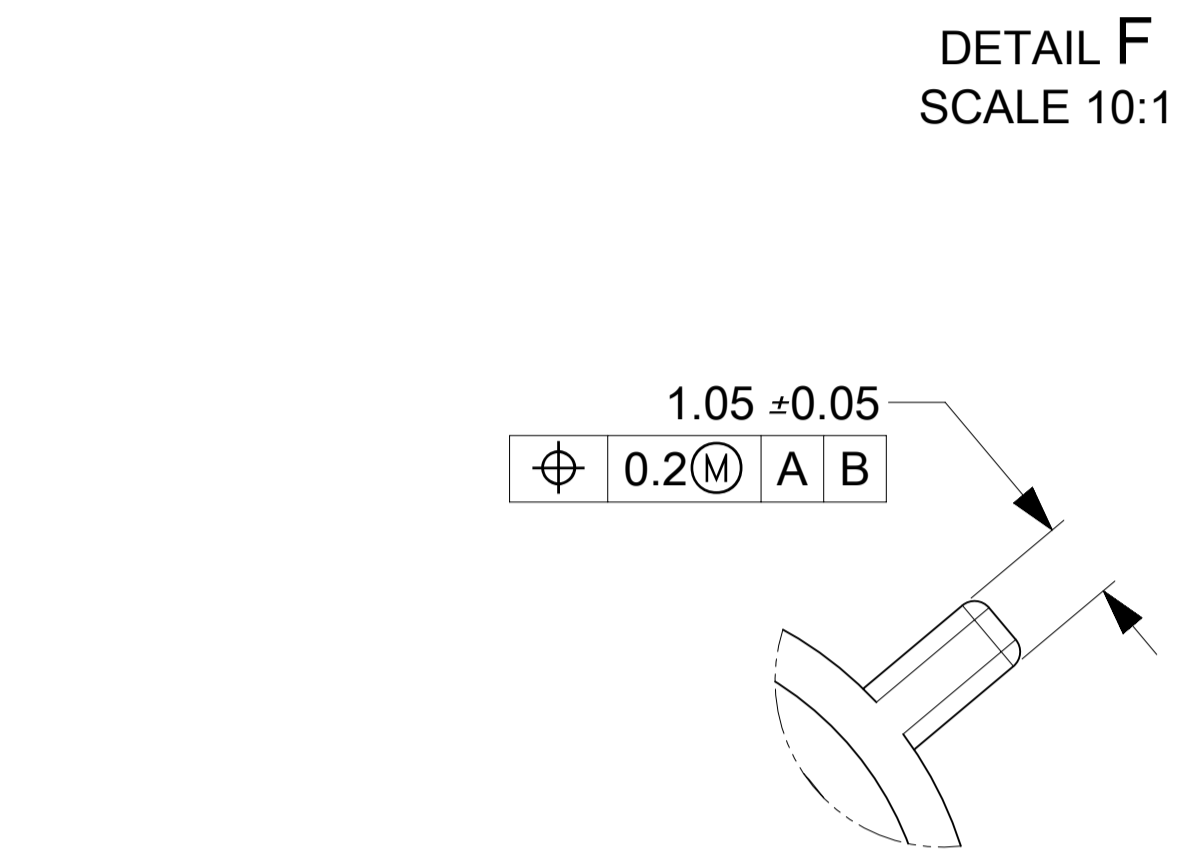

DETAIL C
SCALE 10:1
APPLIES 2X
SEE KEYING OPTION VIEWS
FOR POSITIONS

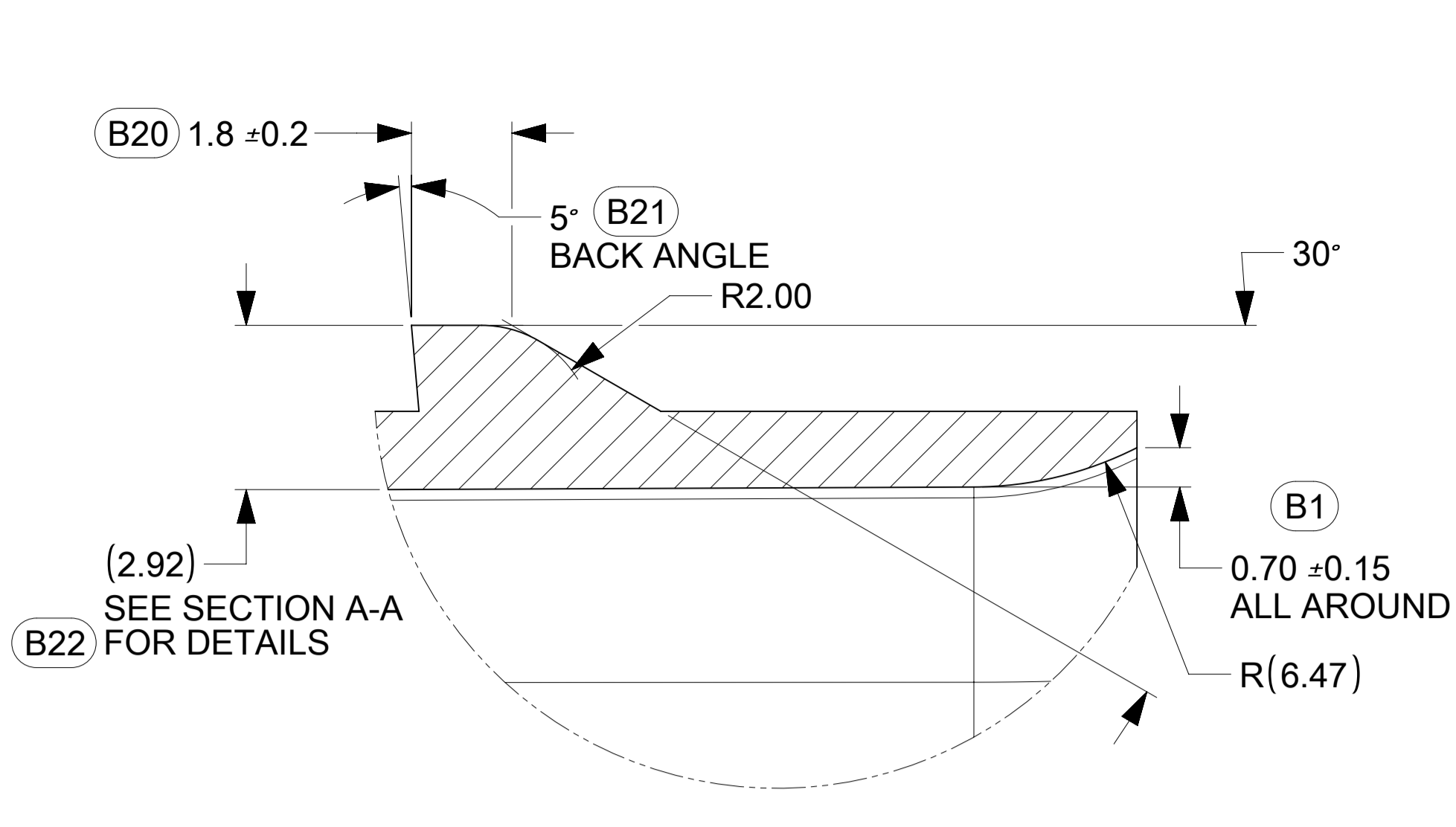
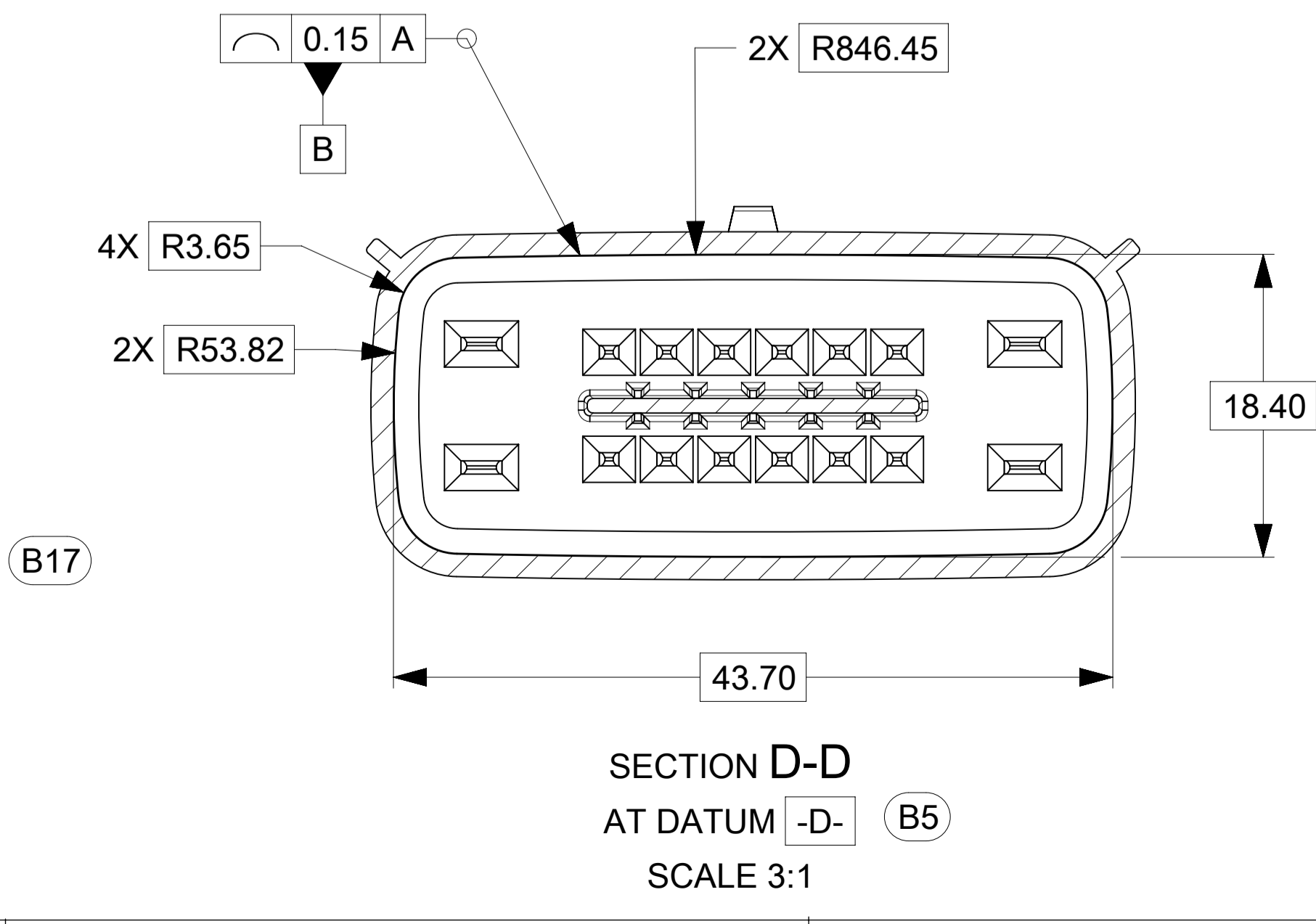
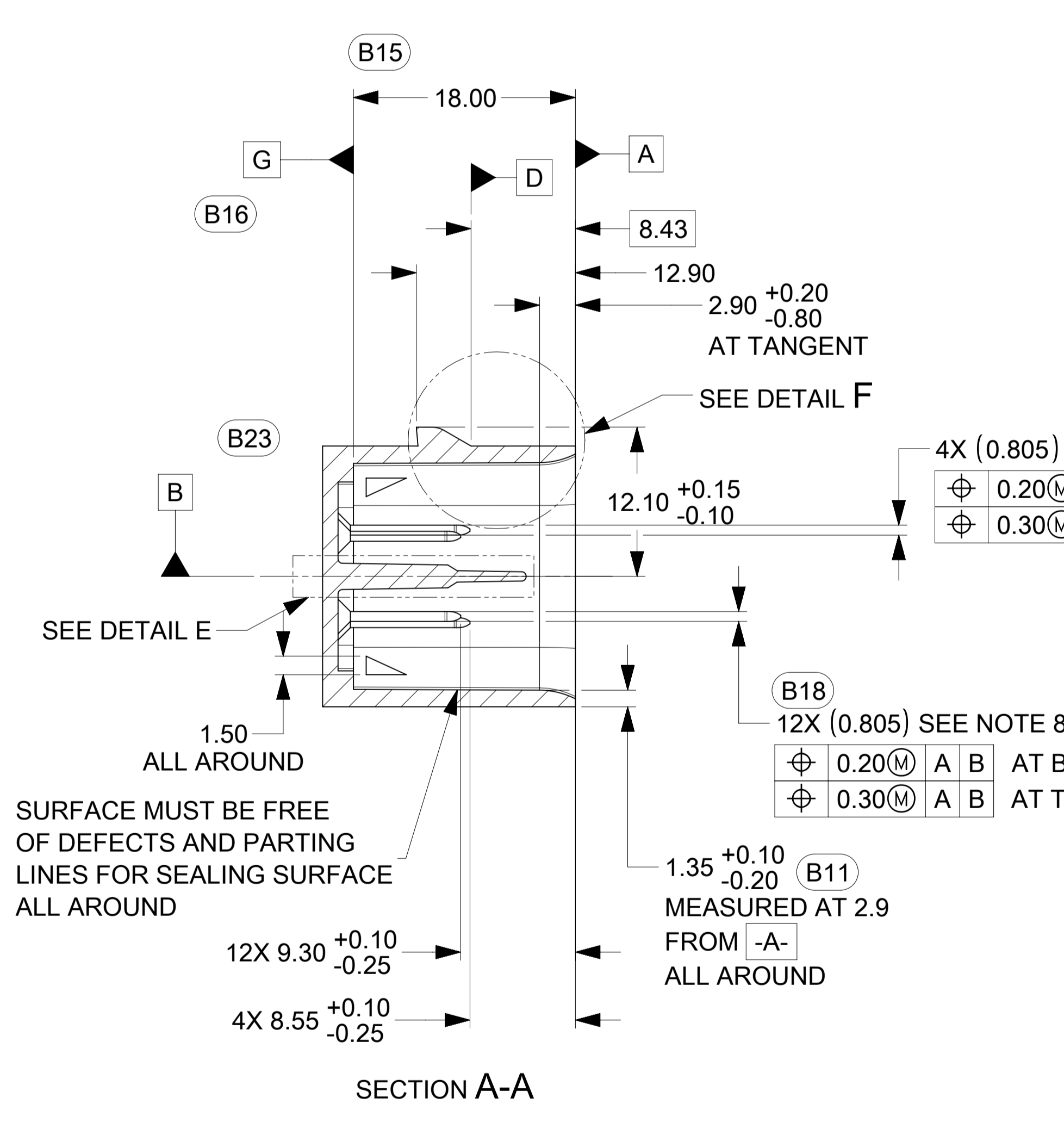

- NOTES: UNLESS OTHERWISE SPECIFIED
- DRAFT ANGLE PERMISSIBLE 0.25° MAXIMUM.
 - ALL DIMENSIONS SHOWN IN MILLIMETERS.
 - DIMENSIONING AND TOLERANCING PER ASME Y14.5M-1994
 - RADII ON ALL CORNERS SHOWN SHARP OR ALL UNSPECIFIED RADII: 0.25 EXCEPT AS NOTED.
 - STANDARD COLORS FOR POLARIZATION (SEE CHART). DEVIATION REQUIRES APPROVAL OF AUTHORIZED PERSON.
 - A FULL SHROUD ON THE MATING CONNECTOR IS REQUIRED TO INSURE THAT THE CONNECTOR-HEADER POLARIZATION FEATURES (OPTIONS A THRU H) WILL FUNCTION. THE SHROUD ALSO PREVENTS SCOOP DAMAGE TO THE HEADER PINS. REFER TO "SAE/USCAR-12 CONNECTOR DESIGN GUIDE LINES" FOR ADDITIONAL INFORMATION.
 - REFER TO USCAR/EWCAP PART LIST AS FOUND ON WEBSITE <http://www.uscarteams.org>
 - FOR BLADE TERMINAL DESIGN INFORMATION SEE EWCAP DWG. # EWCAP-001
 - THIS IS A 100% CAD GENERATED PART. THE CAD MATHEMATICAL DATA IS THE MASTER FOR THIS PART. FOR DIMENSIONAL OR ANY INFORMATION NOT SHOWN ON THIS DRAWING, ANALYZE THE CAD MODEL.

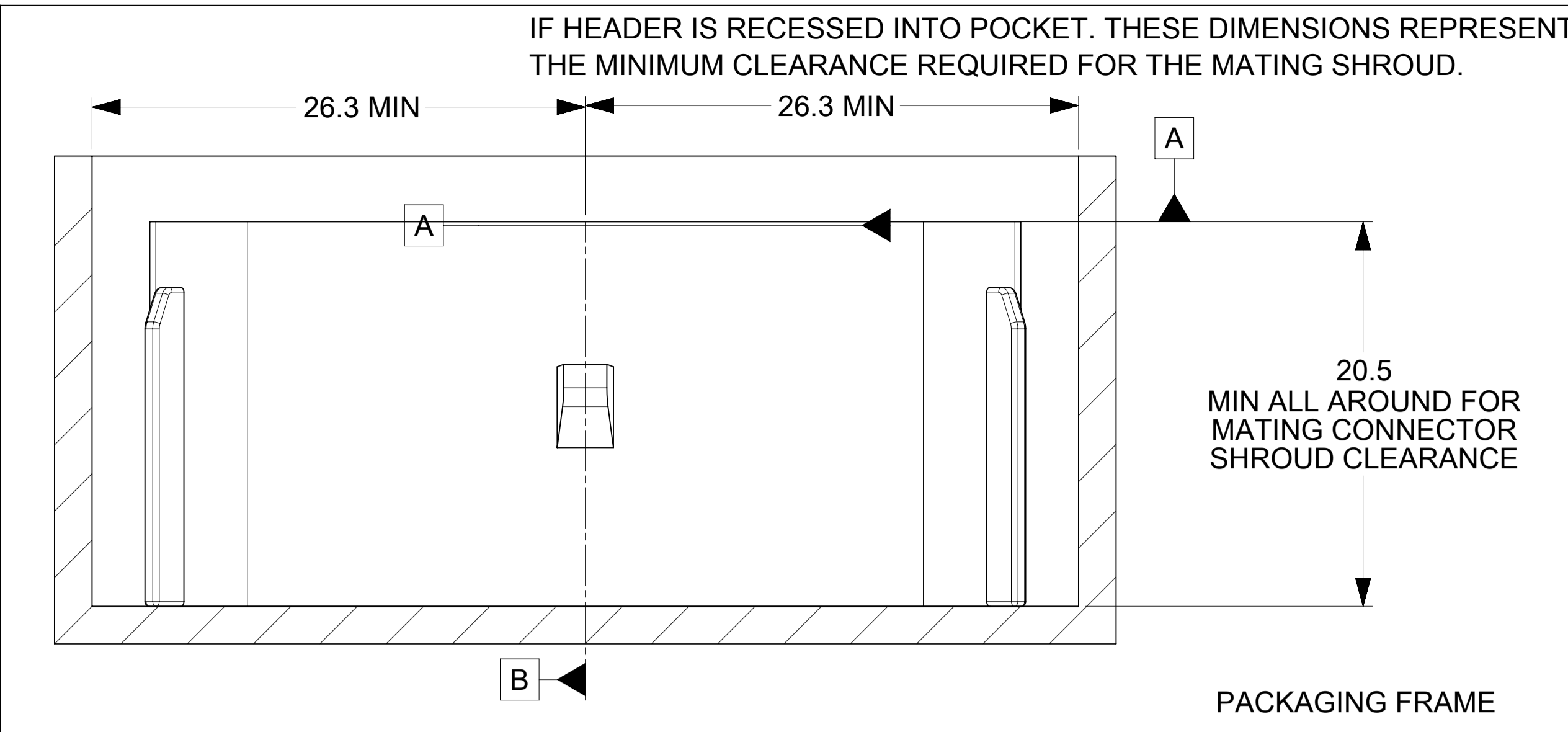

Connector Description	DIMENSION A
CONNECTOR WITHOUT CLIP-SLOT	12.7
CONNECTOR WITH CLIP-SLOT	16.7

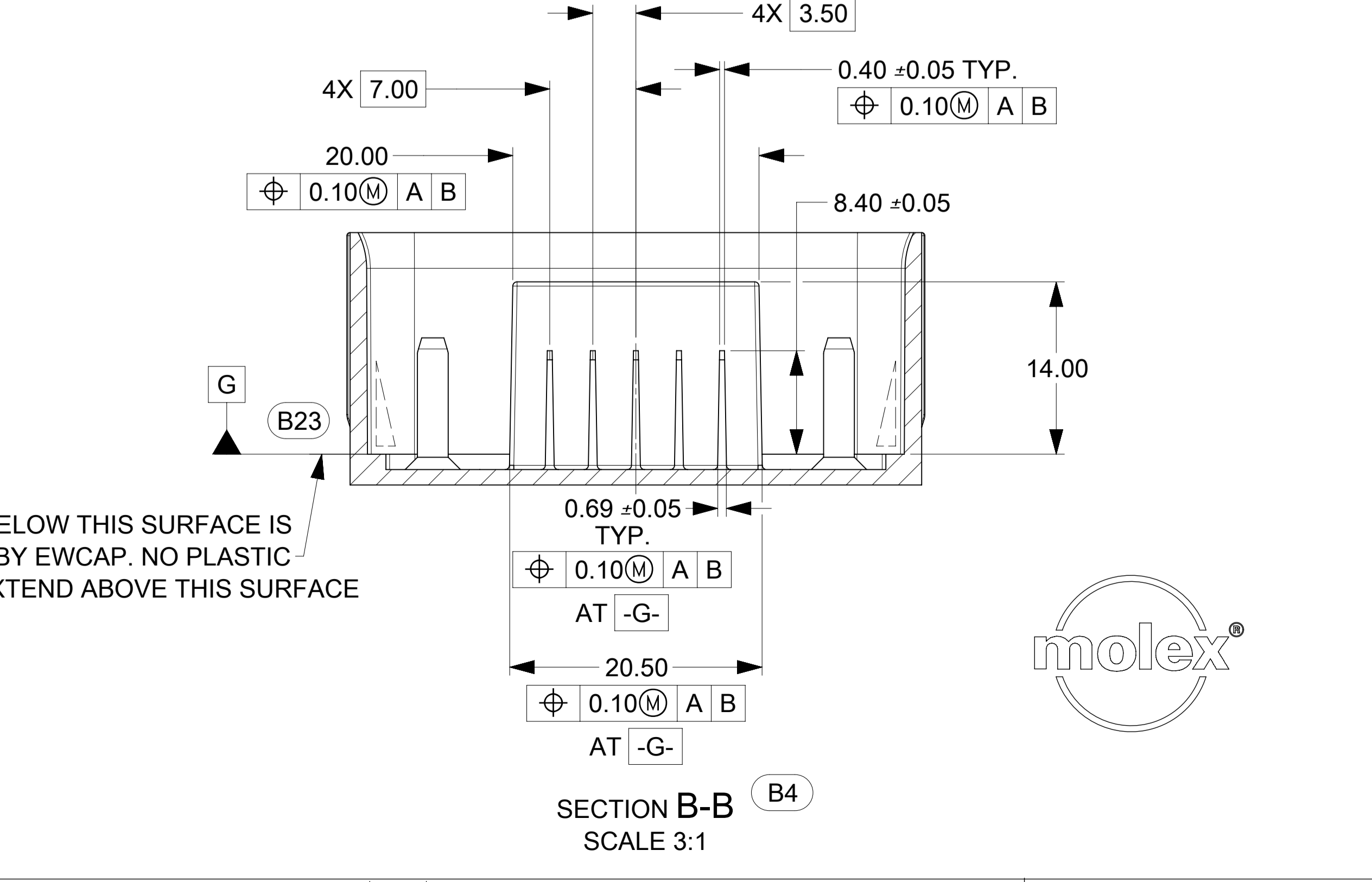
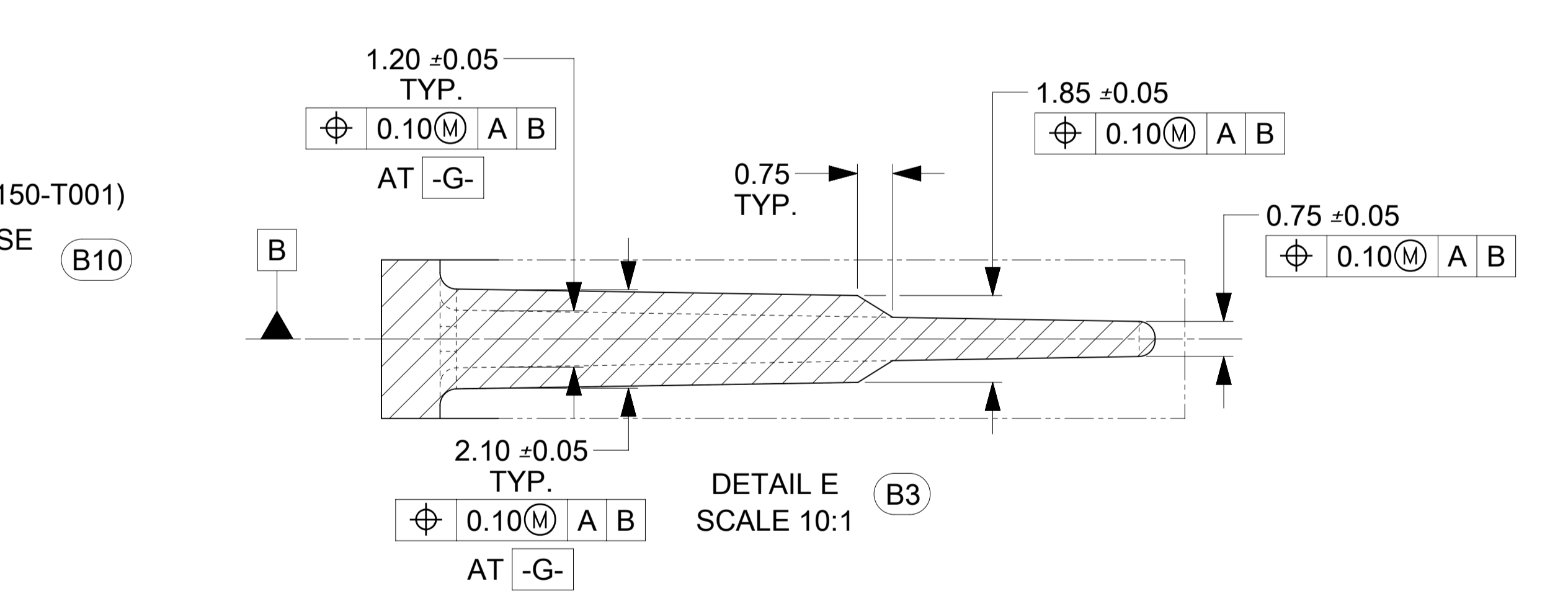
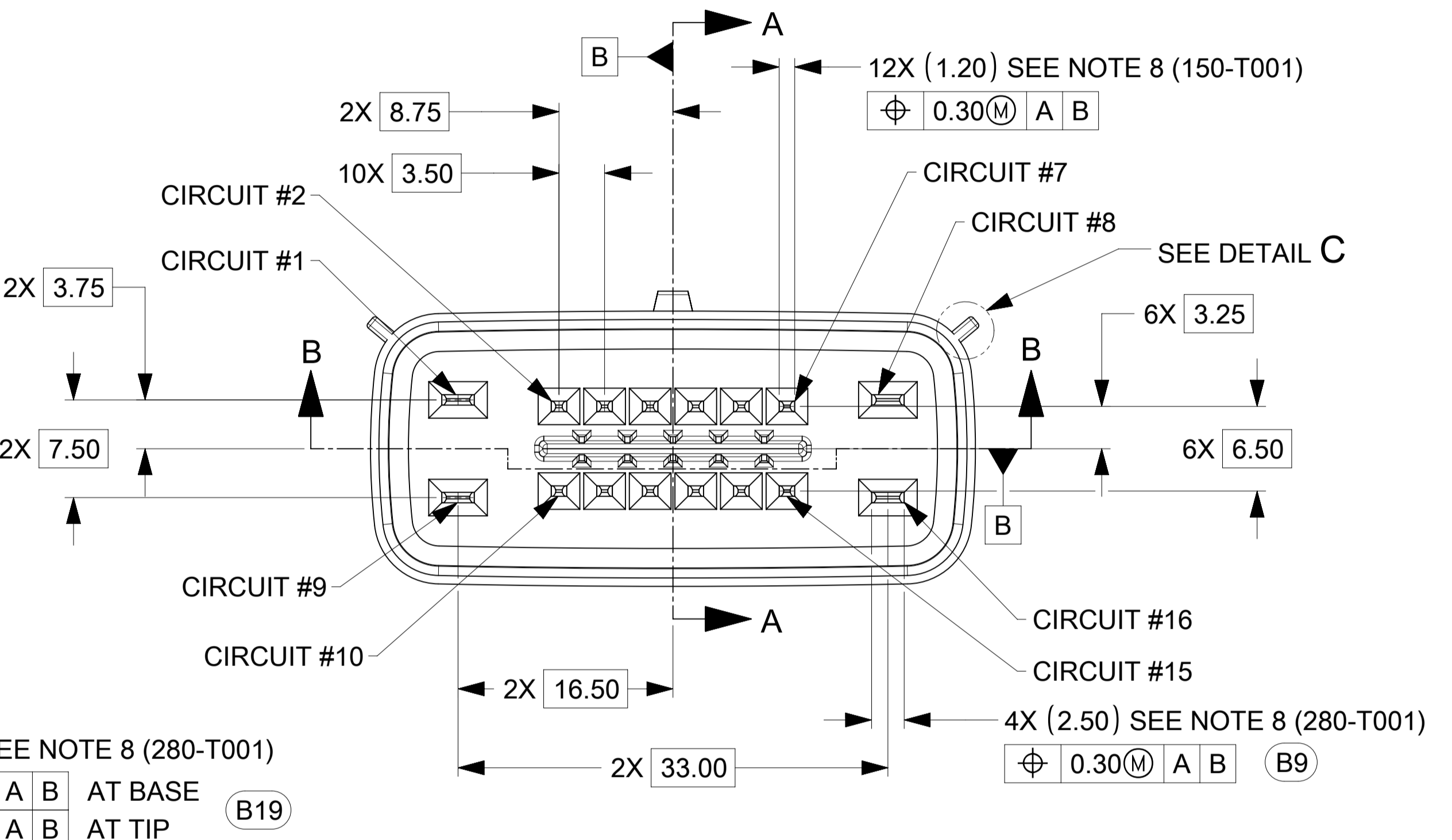
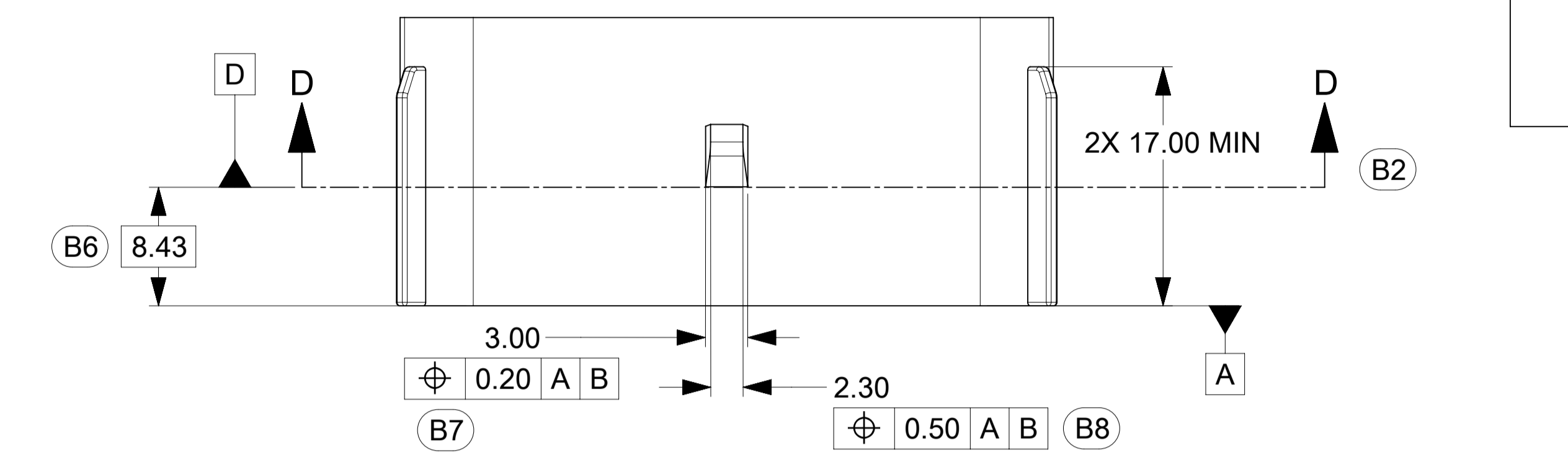

162	C	CHARTED DIMENSION ADDED FOR WITH AND WITHOUT CLIPSLLOT	8-3-20	GE	MV
088	B23	ADDED DRAFT DIRECTION SYMBOL	3-25-11		
088	B22	ADDED REF DIMENSION FOR	3-11-11		
		LATCH HEIGHT			
088	B21	REMOVED THE WORD "OPTION" AT VIEW OF BACK ANGLE	3-11-11		
088	B20	CHANGED FROM 1.79 TO 1.80	3-11-11		
088	B19	ADDED 4X (0.805) AT BASE AND AT TIP FOR 2.8 BLADE TERMINALS	1-14-11		
088	B18	CHANGED 16X TO 12X FOR THE 1.5 BLADE TERMINALS	1-14-11		
088	B17	UPDATED CONNECTOR COLORS	1-14-11		
088	B16	ADDED -G-	5-04-10		
088	B15	REMOVED	5-04-10		
088	B14	REMOVED SHORTING BAR NOTE	5-04-10		
088	B13	UPDATED NOTE 8 REMOVED REV F	5-04-10		
088	B12	ADDED NOTE 9	5-04-10		
088	B11	ADDED DIM 1.35±0.10/-0.20 MEASURED AT 2.9 FROM -A- ALL AROUND	5-04-10		
088	B10	ADDED SEE NOTE 8	5-04-10		
088	B9	2.50 WAS 2.80, ADDED (280-T001)	5-04-10		
088	B8	ADDED	5-04-10		
088	B7	ADDED	5-04-10		
088	B6	ADDED DIM 8.43	5-04-10		
088	B5	ADDED SEC C-C	5-04-10		
088	B4	UPDATED SEC B-B	5-04-10		
088	B3	ADDED DETAIL D	5-04-10		
088	B2	ADDED SEC C-C	5-04-10		
088	B1	ADDED DIM 0.70±0.15 ALL AROUND	5-04-10		
088	B	RELEASED	5-04-10	KC	MV

TOLERANCES (UNLESS OTHERWISE SPECIFIED)		THRU ANGLE PROJECTION																	
DIMENSIONS ARE IN MILLIMETERS		ANGLES ±3°																	
X	±0.2	XX	±0.10																
<table border="1"> <thead> <tr> <th>SCALE</th> <th>DRAWN BY</th> <th>CHECKED BY</th> <th>DATE</th> </tr> </thead> <tbody> <tr> <td>4 - 1</td> <td>G.ELLIOTT</td> <td>M.VANSLAMBROUCK</td> <td>08-03-20</td> </tr> </tbody> </table>				SCALE	DRAWN BY	CHECKED BY	DATE	4 - 1	G.ELLIOTT	M.VANSLAMBROUCK	08-03-20								
SCALE	DRAWN BY	CHECKED BY	DATE																
4 - 1	G.ELLIOTT	M.VANSLAMBROUCK	08-03-20																
<table border="1"> <thead> <tr> <th colspan="4">REVISION RECORD</th> </tr> <tr> <th>LET</th> <th>REVISION</th> <th>DATE</th> <th>CHK</th> </tr> </thead> <tbody> <tr> <td></td> <td></td> <td></td> <td></td> </tr> </tbody> </table>				REVISION RECORD				LET	REVISION	DATE	CHK								
REVISION RECORD																			
LET	REVISION	DATE	CHK																
<table border="1"> <thead> <tr> <th colspan="4">DIRECT CONNECT INTERFACE</th> </tr> <tr> <th colspan="4">16 WAY (2 X 8) 1.5MM SEALED MALE</th> </tr> </thead> <tbody> <tr> <td>DRAWING NUMBER</td> <td>999-S-016-2-Z02</td> <td>SIZE</td> <td>E</td> </tr> <tr> <td>DO NOT SCALE DRAWING</td> <td>COMPUTER AIDED DRAWING</td> <td>REVISION LEVEL</td> <td>C</td> </tr> </tbody> </table>				DIRECT CONNECT INTERFACE				16 WAY (2 X 8) 1.5MM SEALED MALE				DRAWING NUMBER	999-S-016-2-Z02	SIZE	E	DO NOT SCALE DRAWING	COMPUTER AIDED DRAWING	REVISION LEVEL	C
DIRECT CONNECT INTERFACE																			
16 WAY (2 X 8) 1.5MM SEALED MALE																			
DRAWING NUMBER	999-S-016-2-Z02	SIZE	E																
DO NOT SCALE DRAWING	COMPUTER AIDED DRAWING	REVISION LEVEL	C																

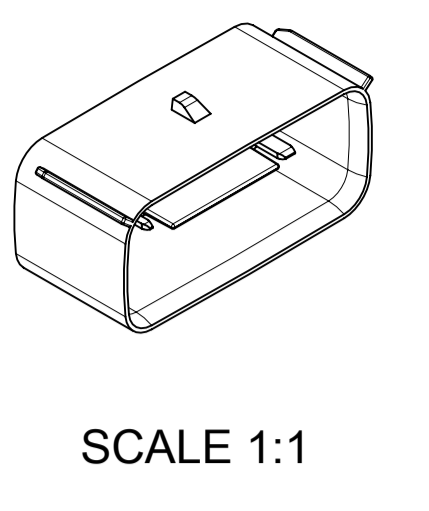

SCALE 1:1

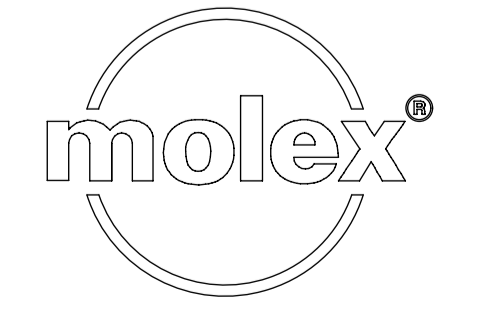

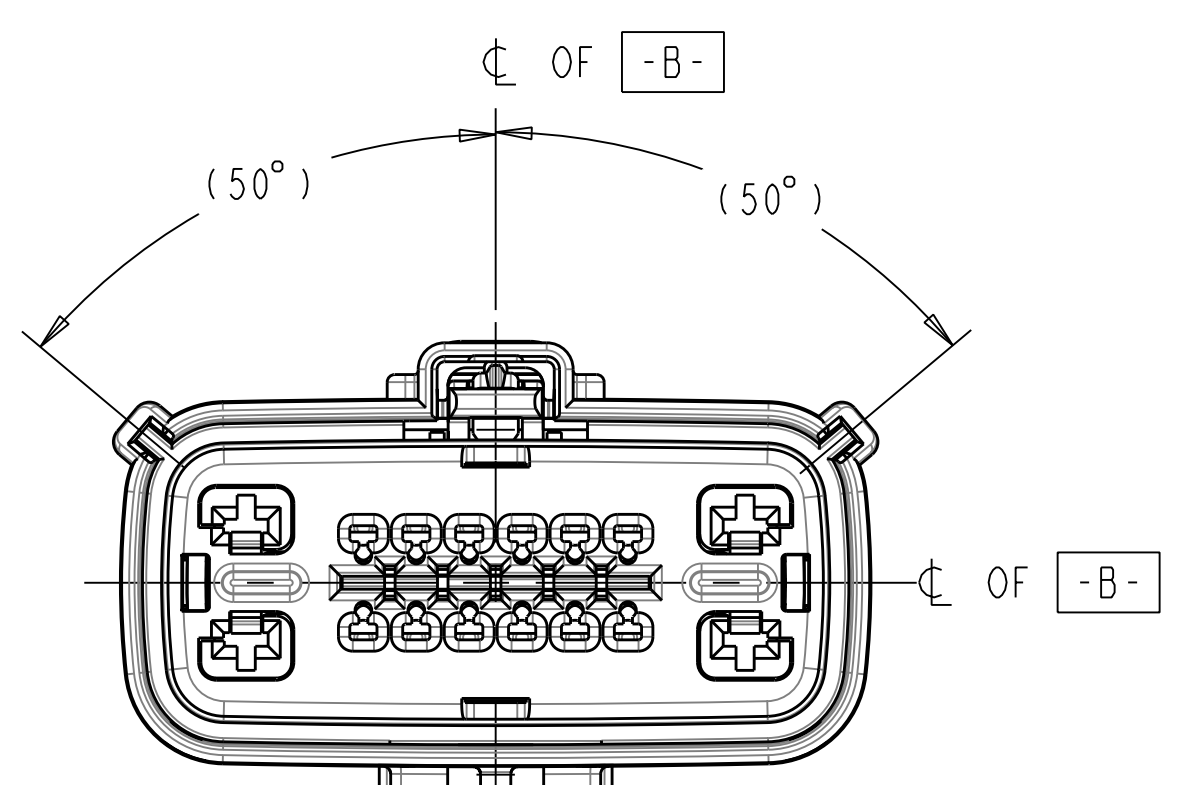

KEYING OPTION A
SCALE 2:1

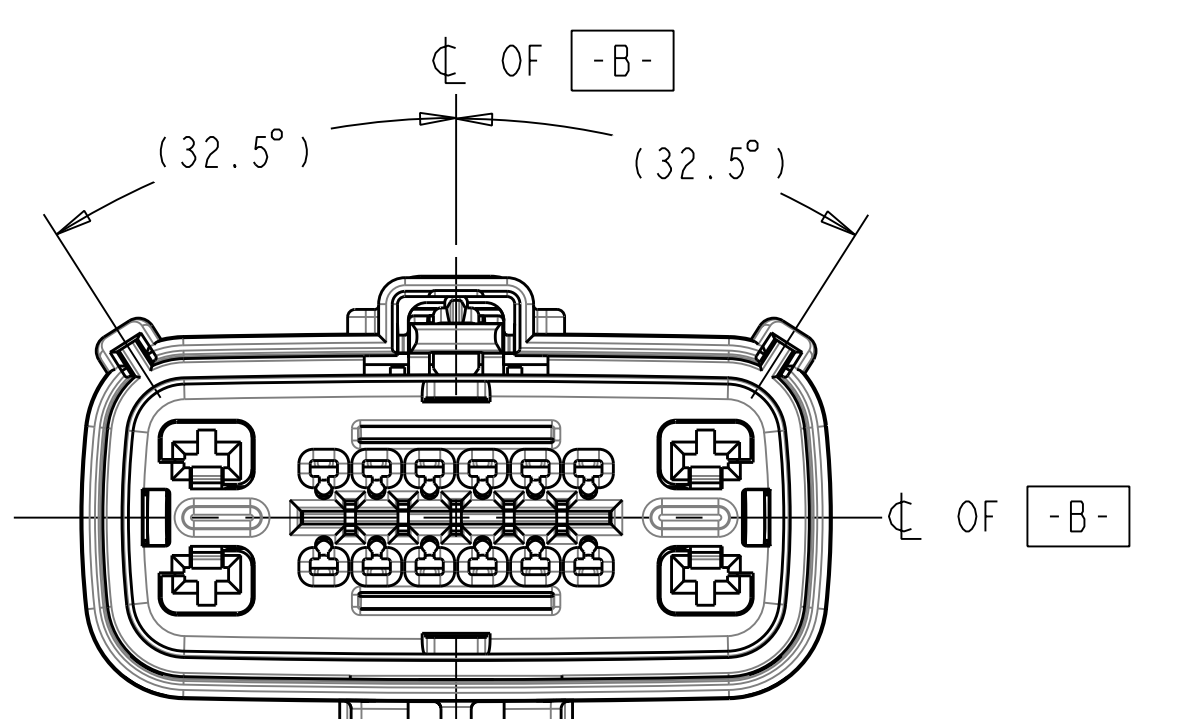

KEYING OPTION E
SCALE 2:1

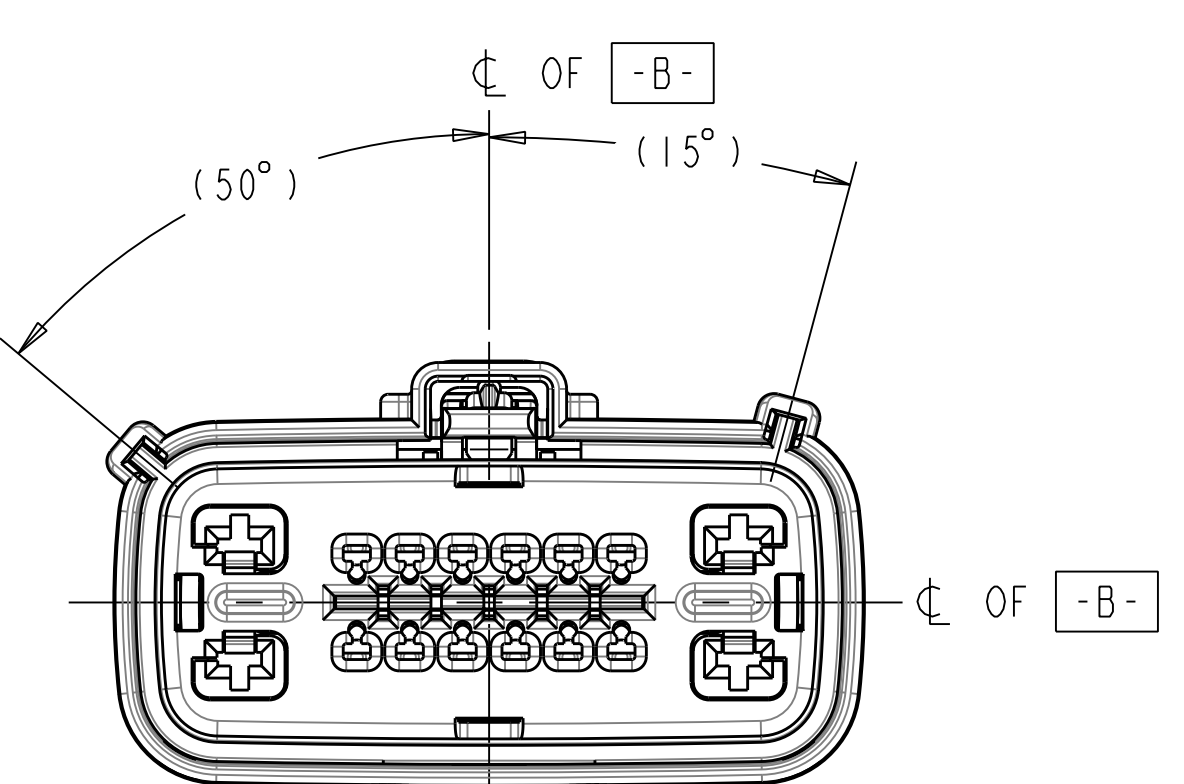

KEYING OPTION B
SCALE 2:1

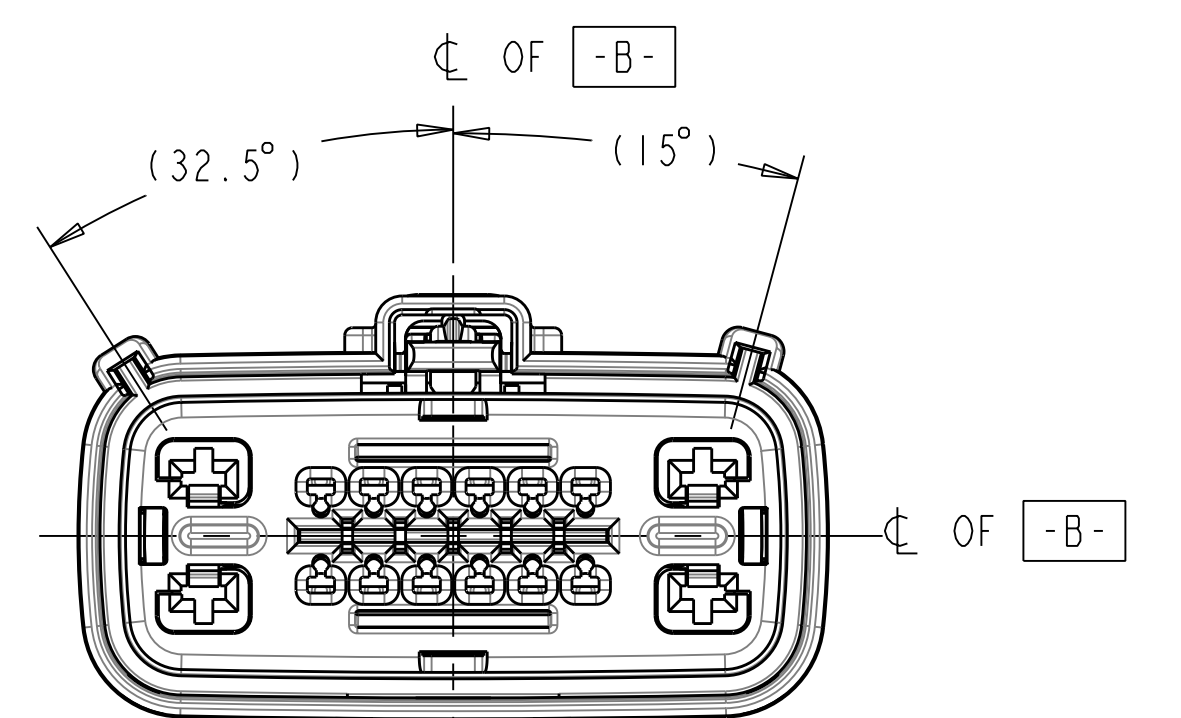

KEYING OPTION F
SCALE 2:1

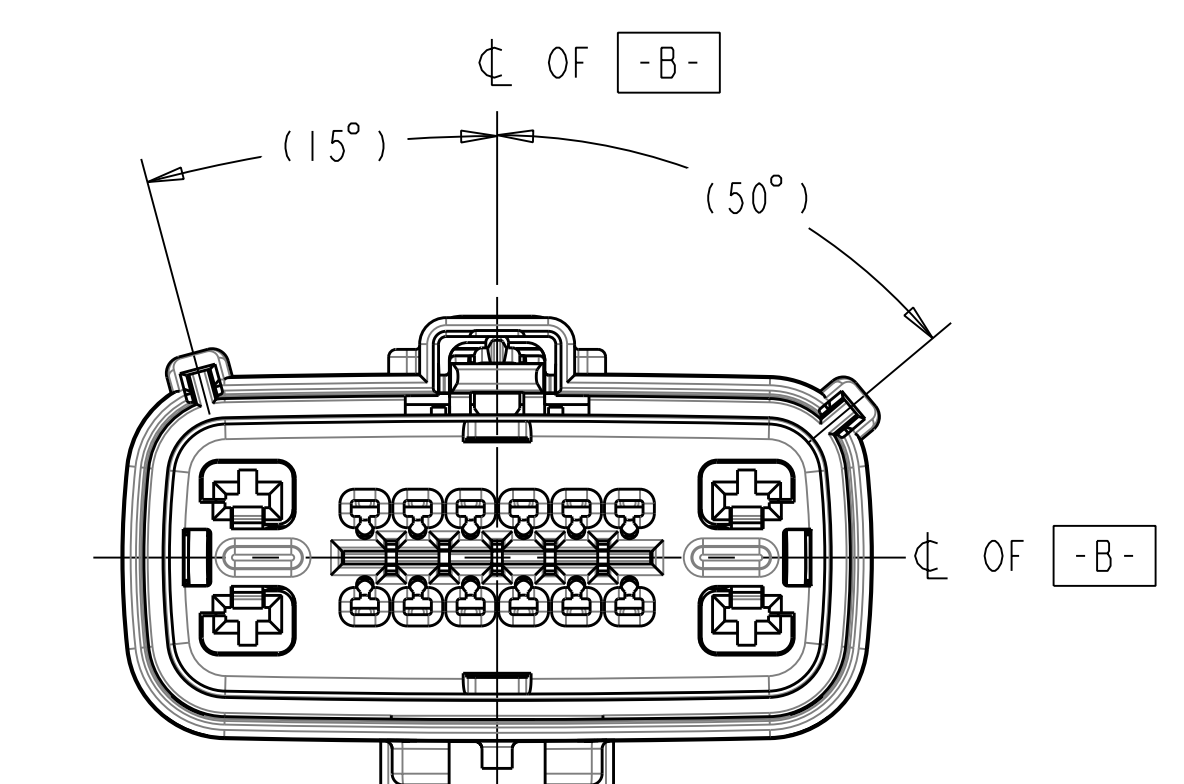

KEYING OPTION C
SCALE 2:1

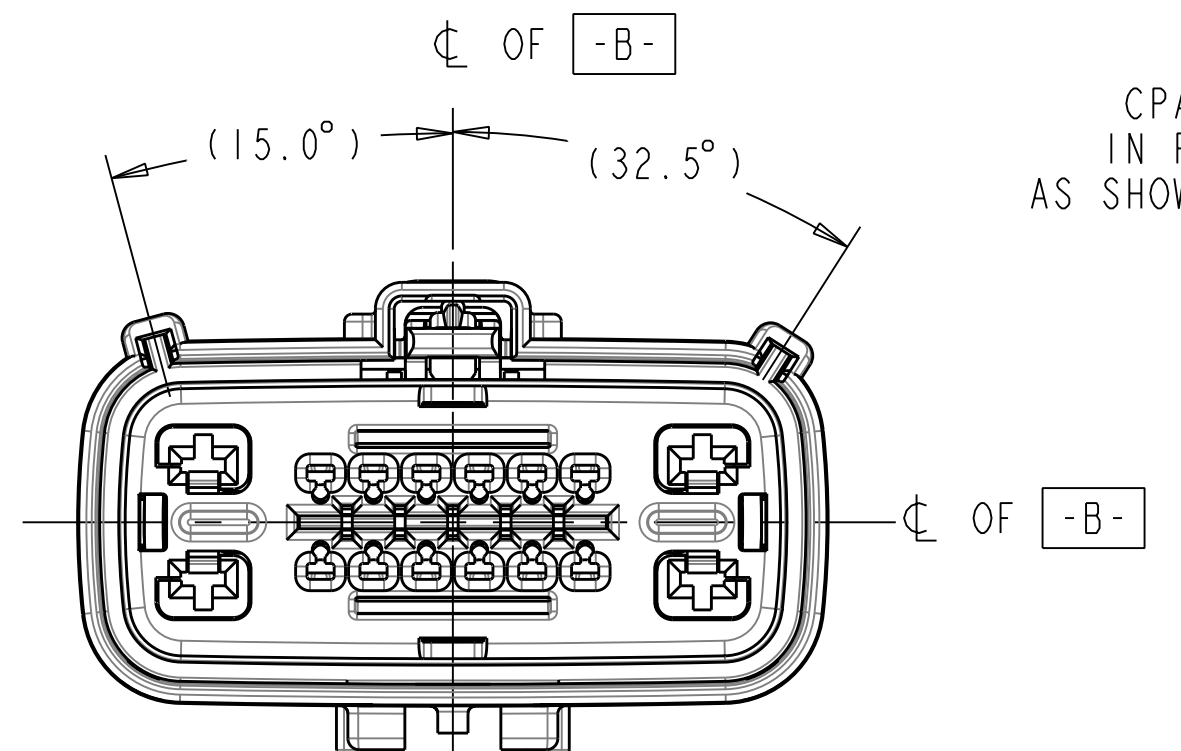

KEYING OPTION G
SCALE 2:1

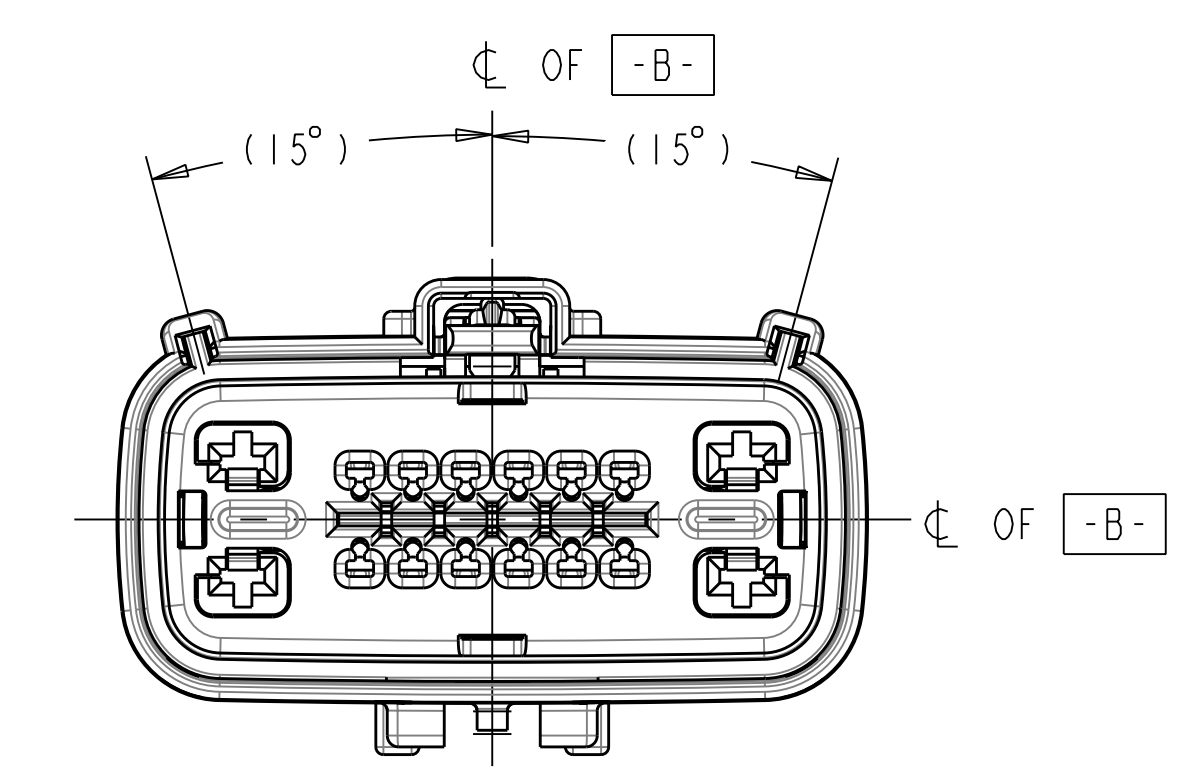

KEYING OPTION D
SCALE 2:1

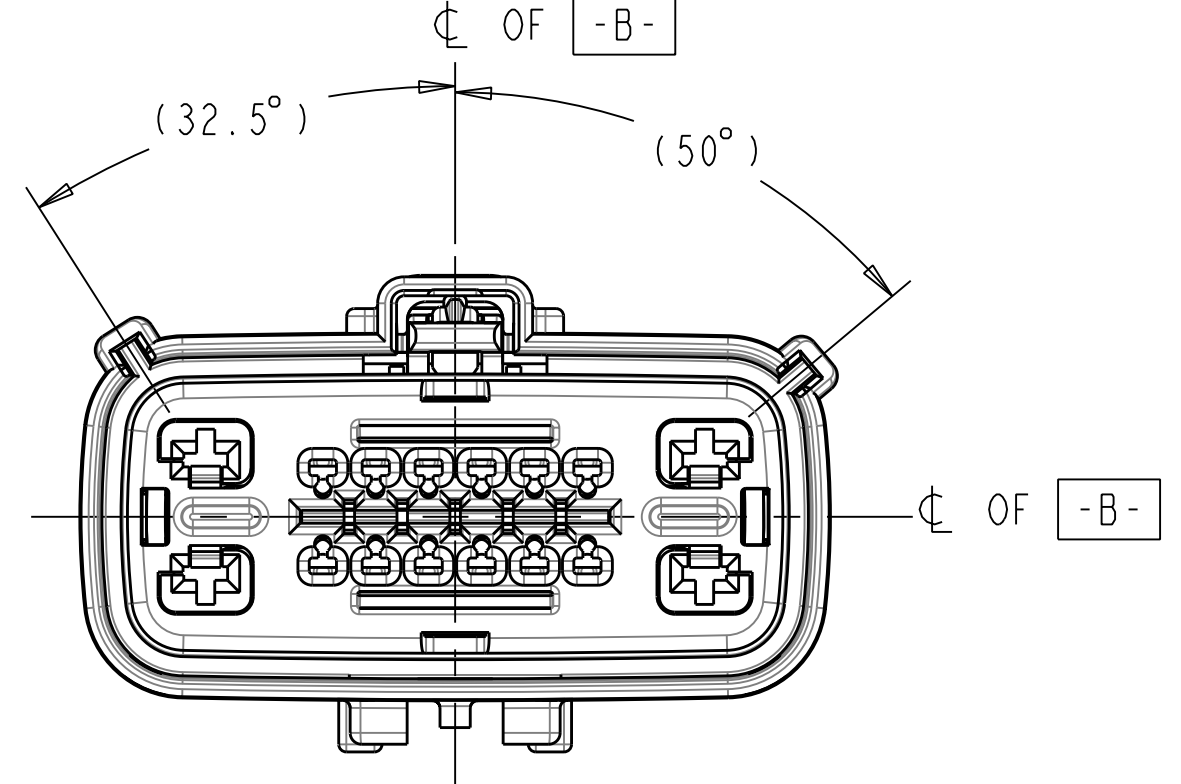

KEYING OPTION H
SCALE 2:1

CPA TO BE INSTALLED
IN PRE-LOCK POSITION
AS SHOWN IN BOTH VIEWS,
SEE NOTE #5

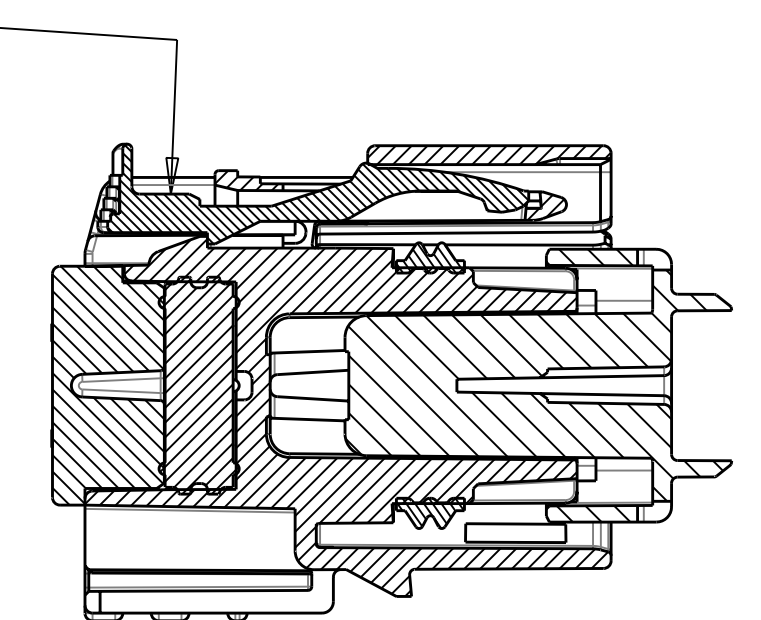

SECTION B-B
(RECEPTACLE INSERT WITH
SHORTING BAR LIFTER
SHOWN IN PRE-LOCK)
SEE NOTE #2

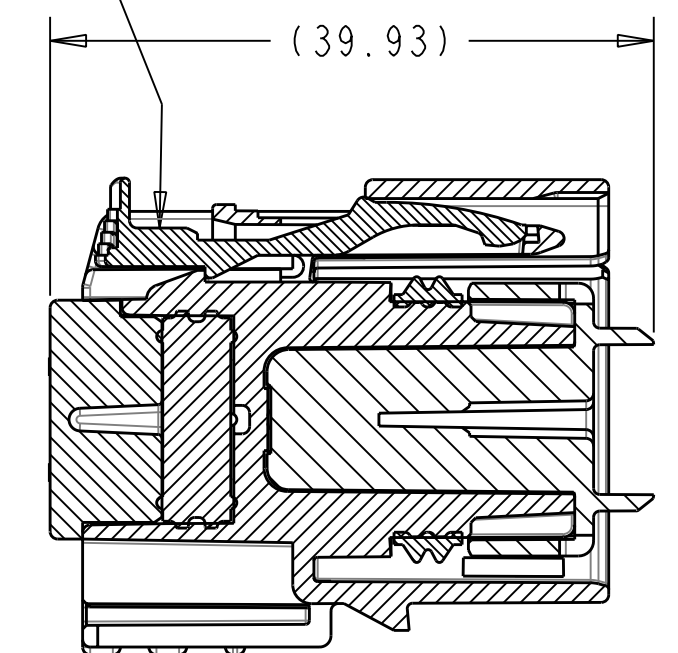

SECTION B-B
(RECEPTACLE INSERT WITH
SHORTING BAR LIFTER
SHOWN IN FULL-LOCK)
SEE NOTE #2

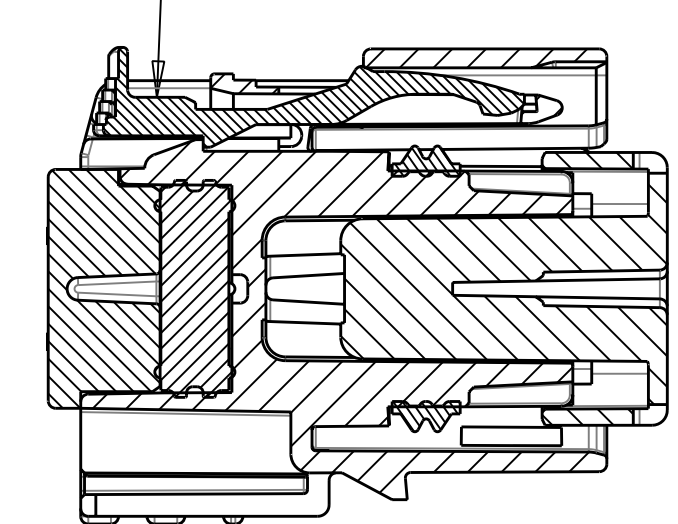

SECTION B-B
(RECEPTACLE INSERT
SHOWN IN PRE-LOCK)
SEE NOTE #2

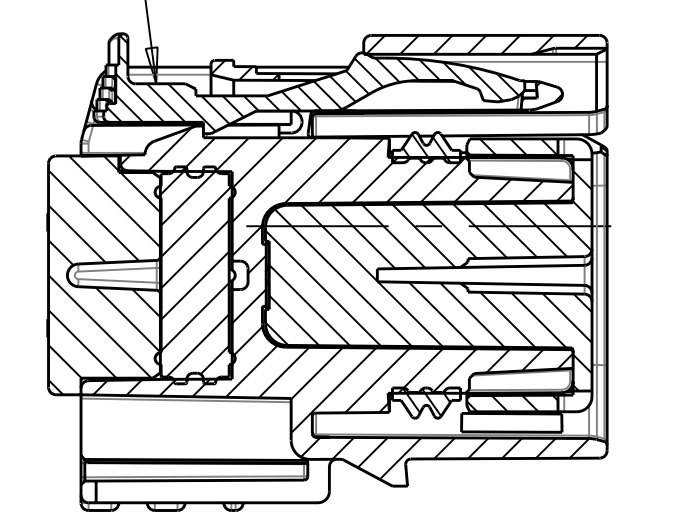

SECTION B-B
(RECEPTACLE INSERT
SHOWN IN FULL-LOCK)
SEE NOTE #2

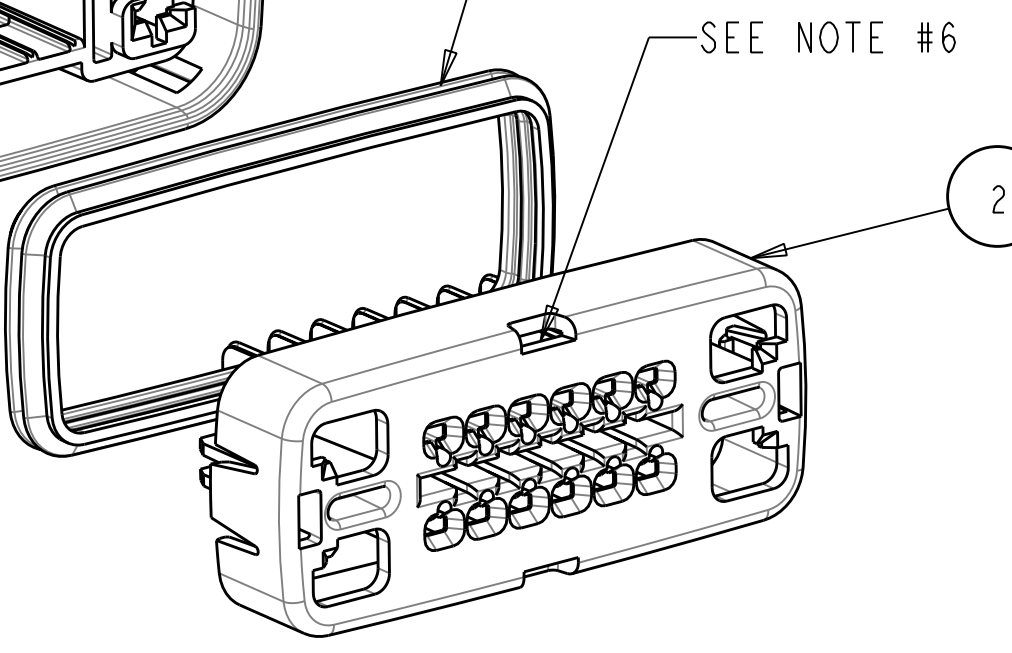
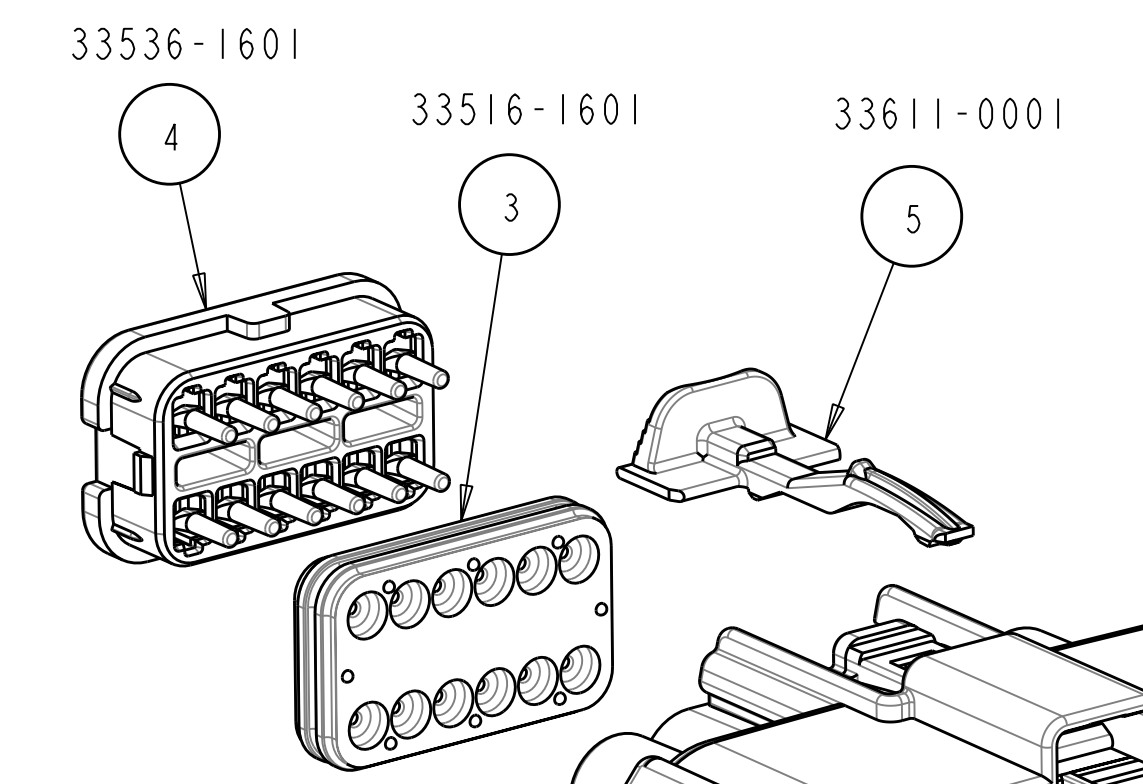

2 33506-1601
33506-1702 (WITH TONGUE)

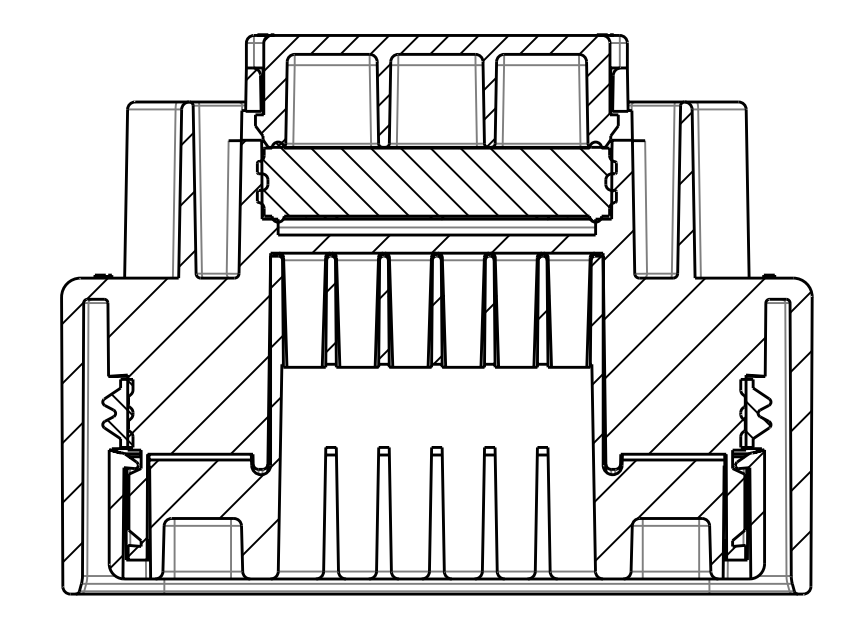

SECTION A-A

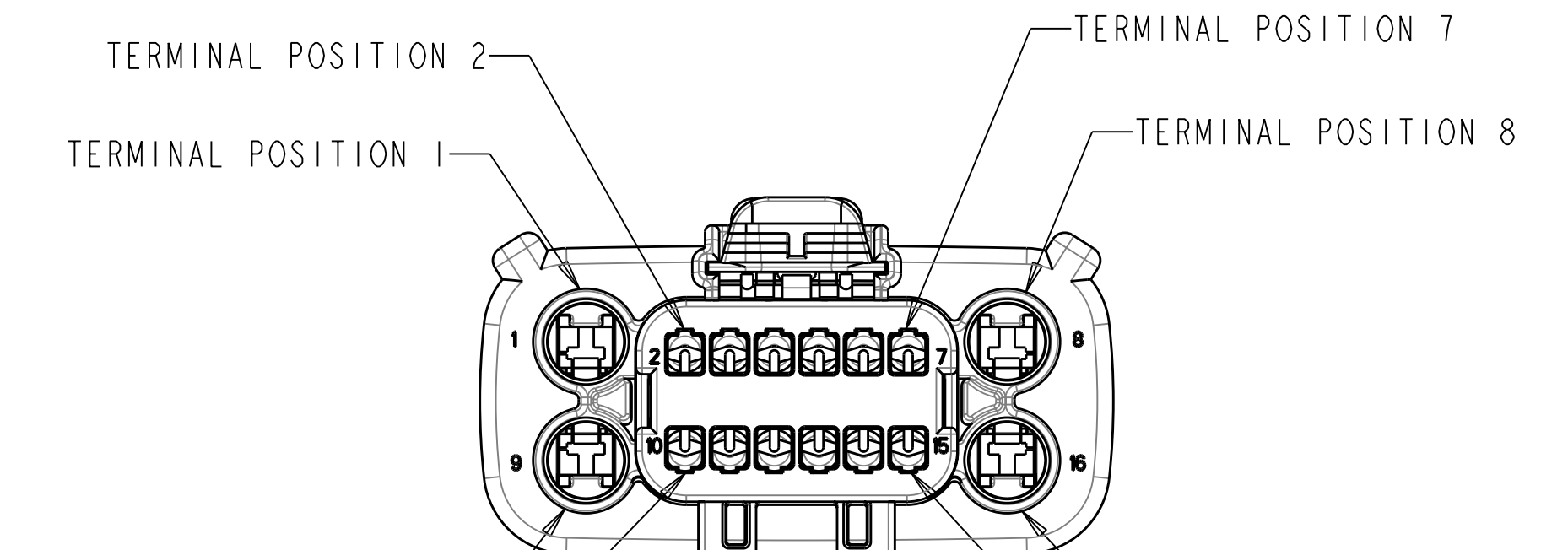

REAR VIEW
(WIRE HARNESS SIDE)

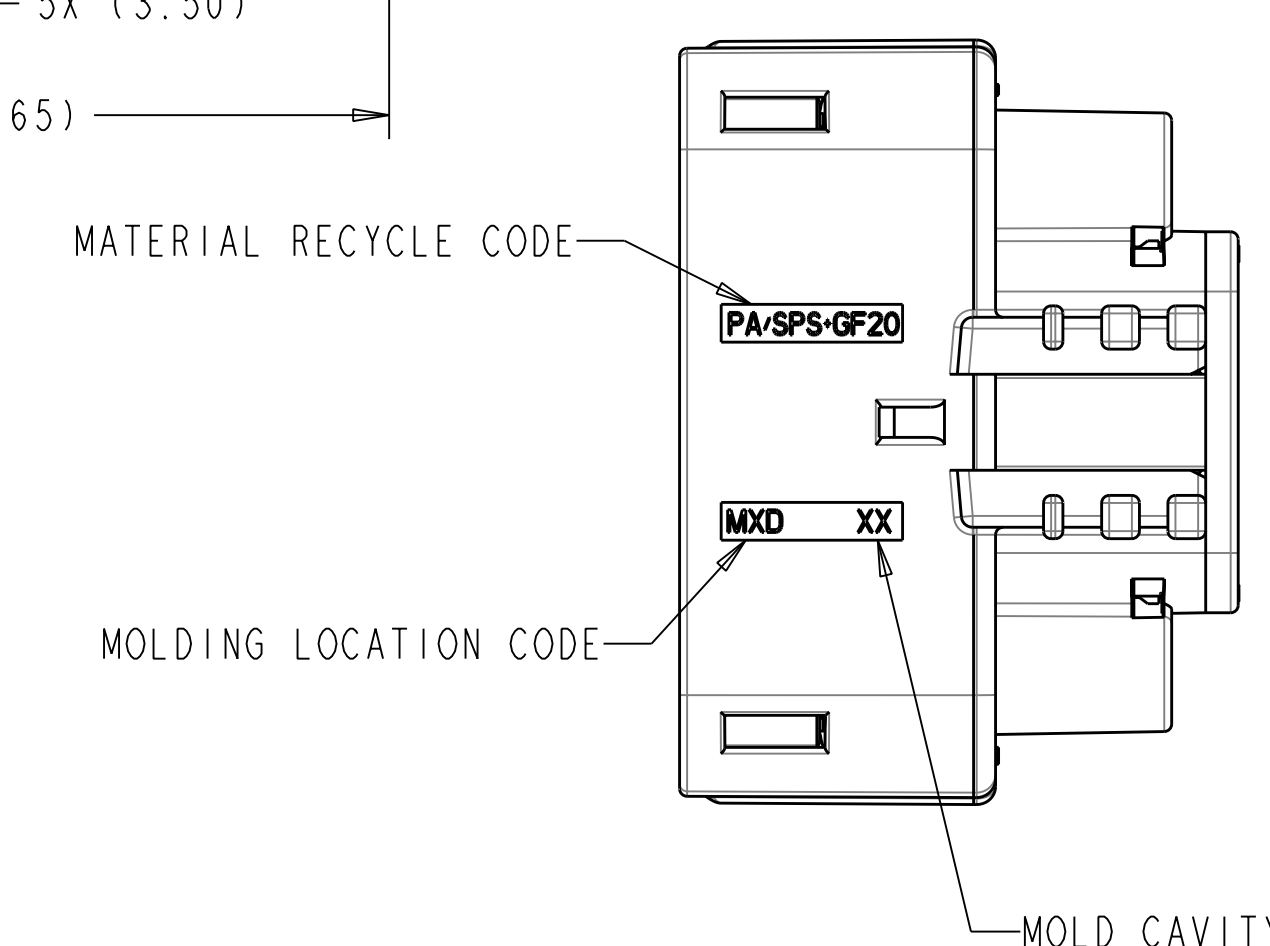
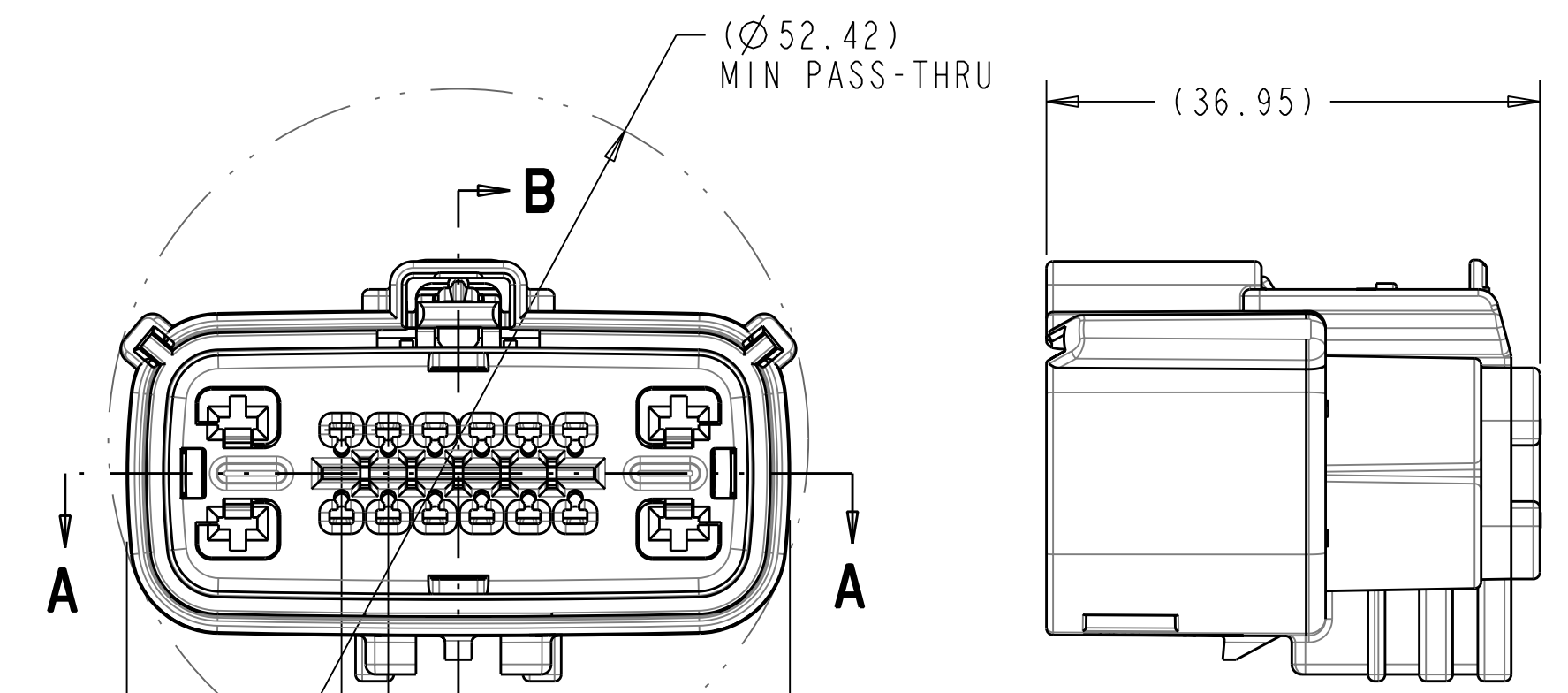

- NOTES: UNLESS OTHERWISE SPECIFIED
- DESIGNED TO MATE WITH BLADE HOUSING ASSEMBLY SPECIFIED IN CHARTED DRAWING E-33486-161 OR DEVICE CONNECTION AS SPECIFIED IN DRAWING E-33586-161. SEE CHART
 - ASSEMBLY SHIPPED WITH RECEPTACLE INSERT IN PRE-LOCK POSITION (SEE SECTION B-B PRE-LOCK). UPON FULL TERMINAL ASSEMBLY, EACH RECEPTACLE INSERT MUST BE SNAPPED INTO ITS FINAL-LOCK POSITION.
 - FOR 1.5mm RECEPTACLE TERMINALS TO BE USED WITH THIS ASSEMBLY, SEE MOLEX DRAWING E-33012-001. FOR FORD 2.8mm FEMALE RECEPTACLE SEE CHART.
 - SYSTEM TO BE USED WITH WIRE WITHIN Ø RANGE OF 1.2mm TO 2.4mm.
 - OPTIONAL CPA SHOWN IN ALL VIEWS. SEE TABLES FOR SPECIFIC ASSEMBLY OPTION AND NUMBER. CPA MUST BE INSERTED TO THE PRE-LOCK POSITION, AS SHOWN IN SECTION B-B. WHEN CORRECTLY SEATED THE CPA DOES NOT MOVE, FREELY.
 - SERVICE WITH SCREWDRIVER.
 - REFER TO TABLE ON SHEET 2 OF THIS DRAWING FOR ALL PART NUMBER CONFIGURATION OPTIONS.
 - REFER TO ASSEMBLY DRAWING E-33476-161 FOR RECEPTACLE WITHOUT CLIP SLOT OPTIONS.
 - 9a. ENGAGEMENT FORCE - NO TERMINALS (PRE TO FINAL): 15N MIN.
9b. ENGAGEMENT FORCE - WITH TERMINALS (PRE TO FINAL): 60N MAX.
9c. DISENGAGEMENT FORCE - WITH TERMINALS (FINAL TO PRE): 18N MIN, 60N MAX.
9d. PARTIALLY INSTALLED TERMINAL DETECTION - 80N MIN OR 40N GREATER THAN (b) WHICHEVER IS GREATER.
9e. REMOVAL FORCE - WITH TERMINALS (FINAL TO OUT OF CONNECTOR): 25N MIN.

TYCO 2.8mm CABLE SEAL TERMINAL	
FORD P/N	GRIP SIZE
IFIT-14474-RA	12
IFIT-14474-JA	14
IFIT-14474-HA	16
IFIT-14474-GA	18
IFIT-14474-FA	20
IFIT-14474-EA	22

EC NO: UAU2005-0053	DRWN: D.GRIFFITHS 08-11-04	CH'K: D.GRIFFITHS 08-11-04	APPR: D.GRIFFITHS 08-11-04
M	REV	DESCRIPTION	

QUALITY SYMBOLS	GENERAL TOLERANCES (UNLESS SPECIFIED)	
	mm	INCH
4 PLACES	± .10	± .004
3 PLACES	± .15	± .005
2 PLACES	± 0.30	± .012
1 PLACE	± 0.75	± .030
	ANGULAR ± 3°	

SCALE 2:1	DESIGN UNITS mm
DIMENSION STYLE mm	
DRAWN BY D.GRIFFITHS	DATE 05-21-03
CHECKED BY D.GRIFFITHS	DATE 05-21-03
APPROVED BY D.GRIFFITHS	DATE 05-21-03

THIRD ANGLE PROJECTION	REVISE ON CAD ONLY
TITLE 1.5mm/2.8mm HYBRID CONNECTOR, RCPT 2 ROW HOUSING w/ CLIP SLOT SEALED, 16 WAY	
MOLEX MOLEX INCORPORATED	
MATERIAL NO. -	DOCUMENT NO. SD-33476-181
SHEET NO. 1 OF 2	

THIS DRAWING CONTAINS INFORMATION THAT IS PROPRIETARY TO MOLEX INCORPORATED AND SHOULD NOT BE USED WITHOUT WRITTEN PERMISSION

