

TOP VIEW - SHOW ORIENTATION OF LEGENDS
IN RESPECT TO THE PCB PIN TERMINALS.

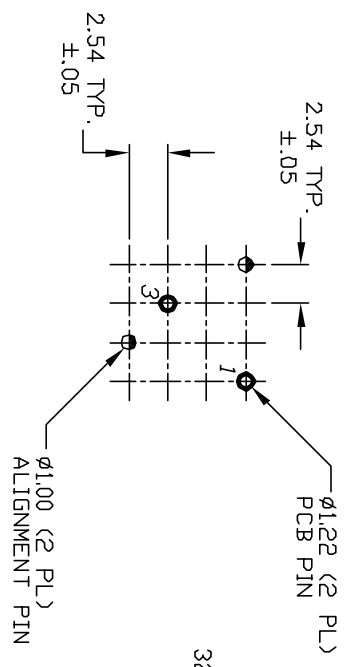

RECOMMENDED P.C.B. LAYOUT

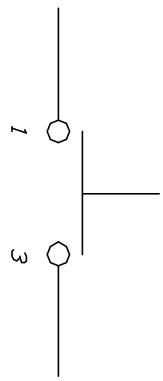
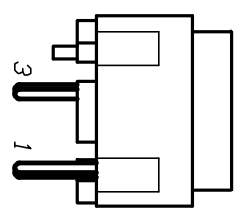
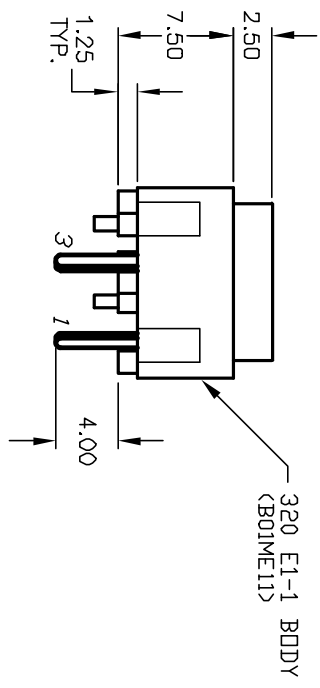
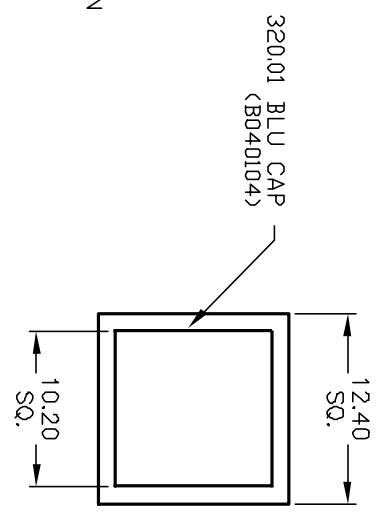

CIRCUIT: SPST
CONTACT CONFIGURATION

- NOTES:
1. ALL DIMENSIONS IN MM
 2. GENERAL TOLERANCE: X.X=±0.4
X.XX=±0.25
 3. TERMINAL NO'S FOR REFERENCE ONLY.
 4. RATING: 25mA, @50VDC
 5. OPERATING FORCE: 120gf
 6. TRAVEL TO MAKE: 0.7mm
 7. USES CONTACT DOME:
[B050001] 320E11 CONTACT DOME

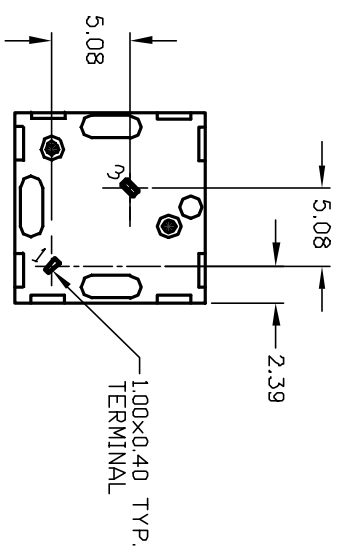

REV.	ECN No.	DESCRIPTION	DATE	CHKD
A	11880	RELEASED FOR PRODUCTION	2/26/03	CJB
THE INFORMATION CONTAINED IN THIS DOCUMENT IS PROPRIETARY TO E-SWITCH AND IS NOT TO BE COPIED OR TRANSMITTED				

TITLE	SCALE	DATE	DR	DWG	REV
320.01 E1-1 BLU	2:1	--	--	XB00484	A

