

ANNA-B112

Stand-alone Bluetooth 5 low energy module

System integration manual

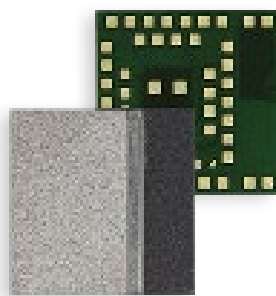

Abstract

This document describes the system integration of ANNA-B112 stand-alone Bluetooth® low energy modules. With embedded Bluetooth low energy stack and u-connectXpress software, this module is tailored for OEMs who wish to have the shortest time-to-market. The OEMs can also embed their own application using for example the Nordic nRF5 SDK, Wirepas Mesh or Arm® Mbed™ integrated development environment (IDE).

Document information

| | | |
|-------------------------------|---|------------|
| Title | ANNA-B112 | |
| Subtitle | Stand-alone Bluetooth 5 low energy module | |
| Document type | System integration manual | |
| Document number | UBX-18009821 | |
| Revision and date | R09 | 9-Feb-2021 |
| Disclosure restriction | C1-Public | |

Document status descriptions

| | |
|------------------------------|--|
| Draft | For functional testing. Revised and supplementary data will be published later. |
| Objective specification | Target values. Revised and supplementary data will be published later. |
| Advance information | Data based on early testing. Revised and supplementary data will be published later. |
| Early production information | Data from product verification. Revised and supplementary data may be published later. |
| Production information | Document contains the final product specification. |

This document applies to the following products:

| Product name | Document status |
|--------------|------------------------|
| ANNA-B112 | Production information |

 For information about the related hardware, software, and status of listed product types, refer to the respective data sheets.

u-blox or third parties may hold intellectual property rights in the products, names, logos and designs included in this document. Copying, reproduction, modification or disclosure to third parties of this document or any part thereof is only permitted with the express written permission of u-blox.

The information contained herein is provided "as is" and u-blox assumes no liability for its use. No warranty, either express or implied, is given, including but not limited to, with respect to the accuracy, correctness, reliability and fitness for a particular purpose of the information. This document may be revised by u-blox at any time without notice. For the most recent documents, visit www.u-blox.com.

Copyright © u-blox AG.

Contents

| | |
|---|-----------|
| Document information | 2 |
| Contents | 3 |
| 1 System description | 6 |
| 1.1 Overview | 6 |
| 1.2 Product features | 7 |
| 1.2.1 Module architecture | 8 |
| 1.2.2 Hardware options | 8 |
| 1.2.3 Software options | 8 |
| 1.3 Pin configuration and function..... | 8 |
| 1.4 Supply interfaces | 9 |
| 1.4.1 Main supply input | 9 |
| 1.4.2 Digital I/O interfaces reference voltage | 9 |
| 1.4.3 VCC application circuits | 9 |
| 1.5 System function interfaces | 10 |
| 1.5.1 Module reset | 10 |
| 1.5.2 Internal temperature sensor | 10 |
| 1.6 Low power clock | 10 |
| 1.6.1 External crystal | 10 |
| 1.6.2 Internal oscillator | 11 |
| 1.6.3 External clock source | 11 |
| 1.6.4 Low power clock settings for u-connectXpress software | 12 |
| 1.6.5 Selecting clock source | 14 |
| 1.7 Debug – serial wire debug (SWD) | 14 |
| 1.8 Serial interfaces | 14 |
| 1.8.1 Universal asynchronous serial interface (UART) | 14 |
| 1.8.2 Serial peripheral interface (SPI) | 15 |
| 1.8.3 I2C interface..... | 15 |
| 1.9 GPIO pins..... | 16 |
| 1.9.1 Analog interfaces..... | 16 |
| 1.10 Antenna interface | 17 |
| 1.10.1 Integrated antenna | 17 |
| 1.10.2 Antenna pin (external antenna)..... | 17 |
| 1.10.3 NFC antenna | 18 |
| 1.11 Reserved pins (RSVD) | 18 |
| 1.12 GND pins | 18 |
| 2 Software | 19 |
| 2.1 u-connectXpress software..... | 19 |
| 2.1.1 Standard edition | 19 |
| 2.1.2 Mesh edition | 19 |
| 2.2 Open CPU..... | 20 |
| 2.2.1 Nordic nRF5 SDK | 20 |
| 2.2.2 Zephyr | 22 |
| 2.2.3 Support – Nordic development forum | 24 |

| | | |
|----------|---|-----------|
| 2.2.4 | Arm Mbed OS | 24 |
| 2.2.5 | Wirepas Mesh..... | 28 |
| 2.2.6 | Saving Bluetooth MAC address and other production data..... | 28 |
| 2.3 | Flashing ANNA-B112 | 29 |
| 2.3.1 | Flashing over UART..... | 30 |
| 2.3.2 | Flashing over the SWD interface..... | 36 |
| 3 | Design-in..... | 39 |
| 3.1 | Overview..... | 39 |
| 3.2 | Antenna interface..... | 39 |
| 3.2.1 | ANNA-B112 Internal antenna design..... | 39 |
| 3.2.2 | ANNA-B112 External antenna design..... | 40 |
| 3.2.3 | General antenna design guidelines..... | 40 |
| 3.3 | Supply interfaces | 44 |
| 3.3.1 | Module supply design | 44 |
| 3.4 | Data communication interfaces | 44 |
| 3.4.1 | Asynchronous serial interface (UART) design..... | 44 |
| 3.4.2 | Serial peripheral interface (SPI) | 45 |
| 3.4.3 | I2C interface..... | 45 |
| 3.5 | NFC interface..... | 45 |
| 3.5.1 | Battery protection | 45 |
| 3.6 | General High Speed layout guidelines | 46 |
| 3.6.1 | General considerations for schematic design and PCB floor-planning..... | 46 |
| 3.6.2 | Module placement..... | 46 |
| 3.6.3 | Layout and manufacturing..... | 46 |
| 3.7 | Module footprint and paste mask..... | 47 |
| 3.8 | Thermal guidelines | 47 |
| 3.9 | ESD guidelines | 47 |
| 4 | Handling and soldering..... | 49 |
| 4.1 | Packaging, shipping, storage, and moisture preconditioning | 49 |
| 4.2 | Handling..... | 49 |
| 4.3 | Soldering..... | 49 |
| 4.3.1 | Reflow soldering process | 49 |
| 4.3.2 | Cleaning..... | 51 |
| 4.3.3 | Potting | 51 |
| 4.3.4 | Other remarks | 51 |
| 5 | Qualifications and approvals | 52 |
| 6 | Product testing..... | 52 |
| 6.1 | u-blox in-series production test | 52 |
| 6.2 | OEM manufacturer production test | 53 |
| 6.2.1 | “Go/No go” tests for integrated devices | 53 |
| | Appendix..... | 54 |
| A | Glossary | 54 |
| B | Antenna reference designs | 55 |
| B.1 | Internal antenna reference design with module at PCB corner..... | 55 |
| B.2 | Internal antenna reference design with module along PCB edge | 57 |

| | |
|---|-----------|
| B.3 Reference design for external antennas (U.FL connector) | 59 |
| B.4 Examples of application ground plane miniaturizations | 61 |
| B.4.1 Example application 1 | 61 |
| B.4.2 Example application 2 | 62 |
| Related documents | 64 |
| Revision history | 65 |
| Contact..... | 66 |

1 System description

1.1 Overview

The ANNA-B112 is an ultra-small, high-performing, standalone Bluetooth low energy module. The System in Package (SiP) module features Bluetooth 5, a powerful Arm® Cortex®-M4 microprocessor with FPU, and state-of-the-art power performance. The ANNA-B112-0XB is delivered with u-connectXpress software that provides support for u-blox Bluetooth low energy Serial Port Service, GATT client and server, beacons, NFC™, and simultaneous peripheral and central roles – all configurable from a host by using AT commands.

The OEMs can also embed their own application using for example the Nordic nRF5 SDK, Wirepas Mesh or Arm® Mbed™, by erasing the pre-flashed u-connectXpress SW or by flashing their application on the empty ANNA-B112-70B module.

The ANNA-B112 module also includes an integrated antenna providing a range of up to 160 m, and an antenna pin for design-in of an external antenna.

ANNA-B112 has full modular approval for Europe (ETSI RED), US (FCC), Canada (IC / ISED RSS), Taiwan (NCC), South Korea (KCC), Japan (MIC), Australia / New Zealand (ACMA), Brazil (Anatel), South Africa (ICASA).

1.2 Product features

| | ANNA-B112 | |
|-------------------------------------|------------|-----|
| Grade | | |
| Automotive | | |
| Professional | • | |
| Standard | | |
| Radio | | |
| Chip inside | nRF52832 | |
| Bluetooth qualification | v5.0 | |
| Bluetooth low energy | • | |
| Bluetooth output power EIRP [dBm] * | 5 / 8 | |
| Max range [meters] * | 160 / 190 | |
| NFC | • | |
| Antenna type (see footnotes) | chip / pin | |
| Application software | | |
| u-connectXpress | • | |
| Open CPU for embedded applications | | • |
| Interfaces | | |
| UART | 1 | ◆ |
| SPI | | ◆ |
| I ² C | | ◆ |
| I ² S | | ◆ |
| PDM and PWM | | ◆ |
| GPIO pins | 11 | 25 |
| AD converters [number of bits] | | 12 |
| Features | | |
| AT command interface | • | |
| MCU (see footnotes) | | M4F |
| RAM [kB] | | 64 |
| Flash [kB] | | 512 |
| Simultaneous GATT server and client | • | ◆ |
| Low Energy Serial Port Service | • | |
| Throughput [Mbit/s] | 0.8 | 1.4 |
| Maximum Bluetooth connections | 7 | 20 |
| Bluetooth mesh | | ◆ |
| FOTA | | ◆ |

* = The different values are for use with internal/external antenna

◆ = Feature enabled by HW. The actual support depends on the open CPU application SW.

pin = Antenna pin
chip = Internal chip antenna
M4F = 64 MHz Arm[®] Cortex-M4 with FPU

Table 1: ANNA-B112 main features summary

1.2.1 Module architecture

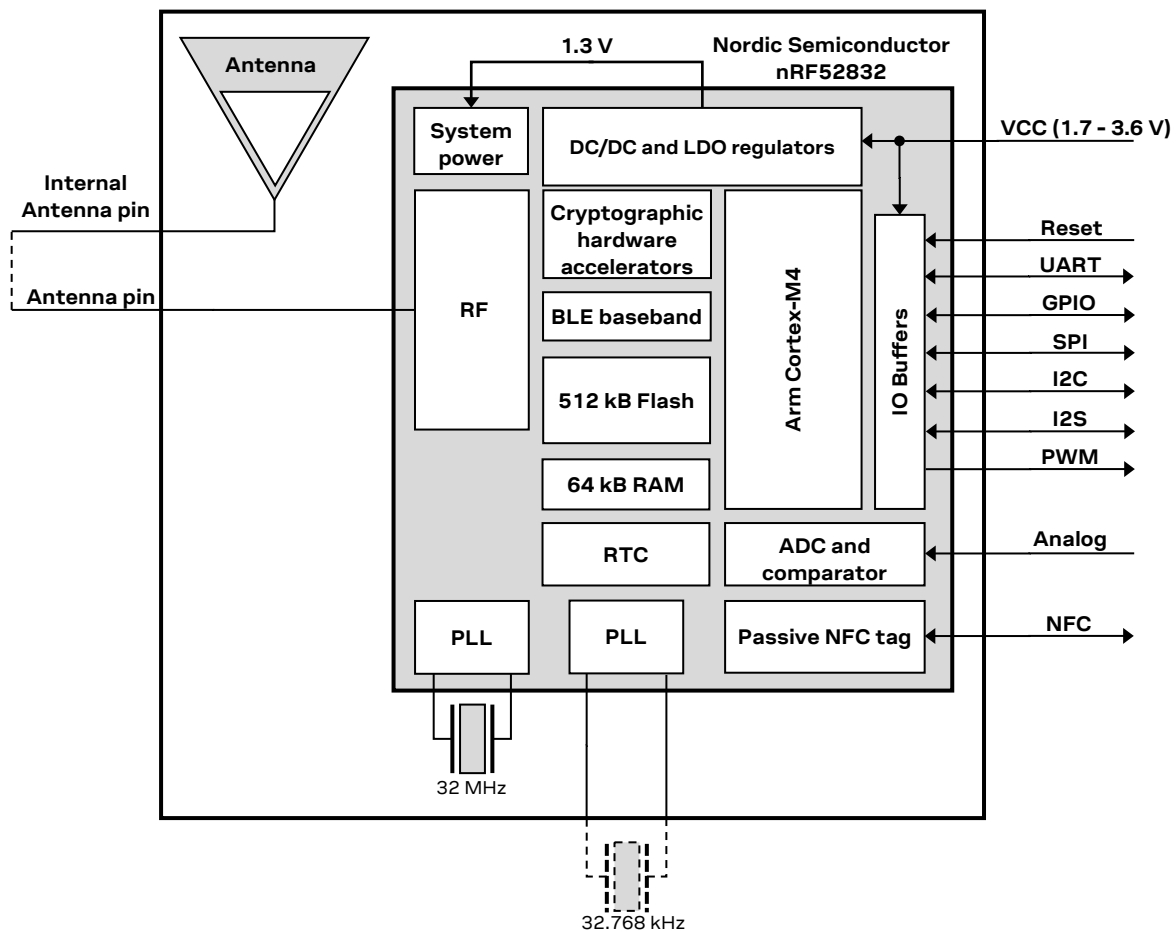

Figure 1: Block diagram of ANNA-B112

1.2.2 Hardware options

The ANNA-B112 module is designed for use with either an internal antenna or by connecting to an external antenna. It contains an integrated DC/DC converter for higher efficiency under heavy load situations. External components are limited to only an optional 32.768 kHz low power crystal.

1.2.3 Software options

The ANNA-B112 module can be used either together with the pre-flashed u-connectXpress software or as an Open CPU module where you can run your own application developed with either Arm® Mbed™, Nordic SDK or Wirepas Mesh development environment inside the ANNA-B112 module. The different software options are described in more detail in section 2.

The u-connectXpress SW comes with a separate mesh SW variant, that is available for download only.

The ANNA-B112-70B variant of the module is delivered with an empty flash. This module variant can be used to avoid an erase operation to remove u-connectXpress when the final product will have a custom application, or when the pre-flashed SW is incompatible with the HW design of the final product.

1.3 Pin configuration and function

See the ANNA-B112 Data sheet [2] for information about pin configuration and function.

1.4 Supply interfaces

1.4.1 Main supply input

The ANNA-B112 module uses an integrated DC/DC converter or LDO to transform the supply voltage presented at the **VCC** pin into a stable system core voltage. Due to this, the ANNA-B112 module is compatible for use in battery powered designs.

While using ANNA-B112 with a battery, it is important that the battery type can handle the peak power of the module. In case of battery supply, consider adding extra capacitance on the supply line to avoid capacity degradation. See the ANNA-B112 data sheet [2] for information about voltage supply requirement and current consumption.

| Rail | Voltage requirement | Current requirement (peak) |
|------|---------------------|----------------------------|
| VCC | 1.7 V – 3.6 V | 15 mA |

Table 2: Summary of voltage supply requirements

 The current requirement in Table 2 considers using the u-connectXpress software with UART communication. But it does not include any additional I/O current. Any use of external push buttons, LEDs, or other interfaces will add to the total current consumption of the ANNA-B112 module. The peak current consumption of the entire design must be considered in battery powered solutions.

1.4.2 Digital I/O interfaces reference voltage

On the ANNA-B112 module, the I/O voltage level is the same as the supply voltage and is internally connected to the supply input **VCC**.

When using ANNA-B112 module with a battery, the I/O voltage level will vary with the battery output voltage, depending on the charge of the battery. Level shifters might be needed depending on the I/O voltage of the host system.

1.4.3 VCC application circuits

The power for ANNA-B112 module is provided through the VCC pins, which can be one of the following:

- Switching Mode Power Supply (SMPS)
- Low Drop Out (LDO) regulator
- Battery

The SMPS is the ideal choice when the available primary supply source has higher value than the operating supply voltage of the ANNA-B112 module. The use of SMPS provides the best power efficiency for the overall application and minimizes current drawn from the main supply source.

 While selecting SMPS, ensure that AC voltage ripple at switching frequency is kept as low as possible. Layout shall be implemented to minimize impact of high frequency ringing.

The use of an LDO linear regulator is convenient for a primary supply with a relatively low voltage where the typical 85-90% efficiency of the switching regulator leads to minimal current saving. Linear regulators are not recommended for high voltage step-down as they will dissipate a considerable amount of energy.

DC/DC efficiency should be evaluated as a tradeoff between active and idle duty cycle of the specific application. Although some DC/DC can achieve high efficiency at extremely light loads, a typical DC/DC efficiency quickly degrades as idle current drops below a few mA, which greatly reduces the battery life.

Due to the low current consumption and wide voltage range of the ANNA-B112 module, a battery can be used as a main supply. The capacity of the battery should be selected to match the application. Care should be taken so that the battery can deliver the peak current required by the module. See the ANNA-B112 data sheet [2] for electrical specifications.

It is considered as best practice to have decoupling capacitors on the supply rails close to the ANNA-B112 module, although depending on the design of the power routing on the host system, capacitance might not be needed.

1.5 System function interfaces

1.5.1 Module reset

You can reset the ANNA-B112 module by applying a low level on the **RESET_N** input pin, which is normally set high with an internal pull-up. This causes an “external” or “hardware” reset of the module. The current parameter settings are not saved in the non-volatile memory of the module and a proper network detach is not performed.

1.5.2 Internal temperature sensor

The radio chip in the ANNA-B112 module contains a temperature sensor used for over temperature and under temperature shutdown.

 The temperature sensor is located inside the radio chip and should not be used if an accurate temperature reading of the surrounding environment is required.

1.6 Low power clock

The ANNA-B112 module uses a 32.768 kHz low power clock to enable different sleep modes. This clock can be generated from an internal or external clock source.

Different options for generating the clock are listed below:

- Internal oscillator
- External crystal oscillator
- External clock source

The u-connectXpress software automatically senses the clock input and uses the external crystal if available; otherwise, it runs the internal oscillator. This automatic sense functionality will add additional time during startup (about 1s). If the startup time is critical or more detailed settings are needed, then set the low power clock settings using AT commands. See section 1.6.4.

To fully utilize the low current consumption of the ANNA-B112 module, an external crystal or external clock source is needed. The internal oscillator will increase the current consumption in sleep mode.

 An external crystal is required by the mesh variant of u-connectXpress as well as some 3rd party SWs like for example Wirepas Mesh.

The following sections describe the different hardware options for the low power clock source and the implications these choices on both the cost and performance of the ANNA-B112 module. For practical guidance on how to configure the oscillator on nRF5 open CPU modules, see the application note [15].

1.6.1 External crystal

The ANNA-B112 has two input pins for connecting an external crystal as source for the low power clock. This setup will enable ANNA-B112 to run with the lowest overall power consumption. Figure 1 shows the components used on the ANNA-B112 EVK.

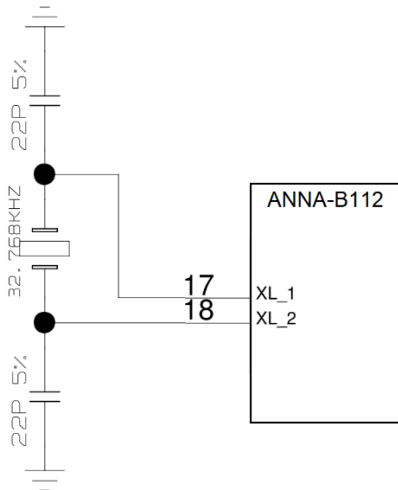
Figure 2: Connecting ANNA-B112 to an external crystal oscillator

| Component | Value | Note |
|--------------------|---------------------|------------------------------------|
| Crystal oscillator | 32.768 kHz – 20 ppm | EPSON FC-12M used on ANNA-B112 EVK |
| Capacitors | 22pF | |

Table 3: Components used on the EVK-ANNA-B112 EVK evaluation kit

1.6.2 Internal oscillator

Using ANNA-B112 with the internal oscillator will enable a minimal BOM, saving cost for the end product. This will however increase the power consumption during sleep.

When using the internal oscillator, the clock pins (pin 17 and pin 18) should be connected to ground.

- ⚠** The application must ensure calibration of the internal oscillator at least once every 8 seconds to ensure +/-250ppm clock stability.

1.6.3 External clock source

An external clock source generated from for example a host CPU can also be used. The clock source can be either low swing signal or full swing signal.

The electrical parameters are stated in Table 4 and Table 5.

| Pin name | Parameter | Min | Typ | Max | Unit | Remarks |
|----------|---|-----|-----|------|------|---|
| XL1 | Input characteristic: Peak to Peak amplitude | 200 | | 1000 | mV | Input signal must not swing outside supply rails. |
| XL2 | - | - | | - | - | Connect to GND |

Table 4: Electrical parameters for a low swing clock

| Pin name | Parameter | Min | Typ | Max | Unit | Remarks |
|----------|---|---------|-----|---------|------|-------------------------------------|
| XL1 | Input characteristic: Low-level input | 0 | | 0.3*VCC | V | |
| | Input characteristic: high-level input | 0.7*VCC | | VCC | V | |
| XL2 | - | - | - | - | - | Connect to GND or leave unconnected |

Table 5: Electrical parameters for a full swing clock

1.6.4 Low power clock settings for u-connectXpress software

The low power clock settings for the u-connectXpress software are stored in a special flash area and can only be written only once. The only way to clear the settings is to erase the flash memory. See section 2.3.2 for details on SWD flashing.

This section describes the AT command and the available settings for the low power clock.

This AT command requires the module to be set in production mode.

- AT+UPROD=1
 - Set the module in production mode
- AT+UPRODLFCLK=(for details see tables below)
 - Command to change the settings on the low power clock
- Reset the module to restart in normal connectivity software

Description

| AT Command | Description |
|--|-------------|
| AT+UPRODLFCLK=<source>[,<value1>[,<value2>]] | |

Syntax

| Response | Description |
|---|--|
| OK | Successful response to AT+UPRODLFCLK=<source>[,<accuracy>] |
| +UPRODLFCLK: <source>[,<value1>[,<value2>]] OK | Successful response to AT+UPRODLFCLK |
| ERROR | When command fails |

Defined values

| Parameter | Type | Description |
|-----------|--------|--|
| <source> | Number | Allowed values are: (default = automatic detection) 0: Internal oscillator 1: External crystal 3: External clock |
| <value1> | Number | When <source> = 0; internal oscillator: (default = 16) Calibration timer interval in 1/4 second, allowed 1-32 When <source> = 1; external crystal: External crystal accuracy: (default = 7) 0: 250 PPM 1: 500 PPM 2: 150 PPM 3: 100 PPM 4: 75 PPM 5: 50 PPM 6: 30 PPM 7: 20 PPM 8: 10 PPM 9: 5 PPM 10: 2 PPM 11: 1 PPM |
| <value2> | Number | When <source> = 0; internal oscillator: (default = 2) Temperature change calibration interval: 0: Always calibrate even if the temperature has not changed. 1: Invalid, do not use 2-32: Check the temperature and only calibrate if it has changed, however calibration will take place every X intervals even if no change in temperature. |

Table 6: Settings

The internal oscillator needs to be calibrated to maintain its accuracy. The interval of the calibration should be selected so that the temperature does not change more than 0.5 °C between calibrations.

There are two settings for the calibration - Calibration timer interval and Temperature change calibration interval.

- *Calibration timer interval* sets the interval when the need for calibration is checked.
- Temperature change calibration interval sets the number of calibrations timer intervals counted before a calibration is forced.
 - 0: Always calibrate even if the temperature has not changed.

- 2-32: Check the temperature and calibrate only if it has changed; however, calibration will take place every X count of the *calibration timer interval* even if there is no change in the temperature.

Calibrating the unit more often will increase the current consumption.

- ⚠ When using internal oscillator as source the user must make sure that the settings calibrate the internal oscillator at least once every 8 seconds to ensure +/-250ppm clock stability. It is recommended to keep the default values as stated in Table 6.

1.6.5 Selecting clock source

As described above, the selection of clock source is a tradeoff between BOM count and current consumption. The increase in current consumption when using the internal oscillator will depend on both the software settings as well as the surrounding environment.

The internal oscillator itself will add about 400 nA and the calibration will add about 1 μ A, depending on the above-mentioned settings. The standby current of ANNA-B112 will then increase from 2.2 μ A to 3.6 μ A, an increase of about 60%.

For the active use cases when the module is not in standby the increase of current is negligible. So if the application will be in standby for longer periods of time then an external crystal might be worth adding.

Table 7 shows the average current consumption for a beacon advertising at different intervals, both with external crystal oscillator as well as internal oscillator. The use case is an advertisement event (4.7 ms), +4 dBm output power and 31 bytes payload at 3.3 V.

| Advertise interval | External crystal oscillator | Internal oscillator | Increase in current |
|--------------------|-----------------------------|---------------------|---------------------|
| 1 s | 18 μ A | 19.5 μ A | 8 % |
| 10 s | 3.8 μ A | 5.2 μ A | 37 % |
| 60 s | 2.4 μ A | 3.9 μ A | 63 % |

Table 7: Average current consumption (theoretical calculations)

1.7 Debug – serial wire debug (SWD)

The primary interface for debug is the SWD interface. The SWD interface can also be used for software upgrade.

The two pins, **SWDIO** and **SWDCLK**, should be made accessible on header or test points.

1.8 Serial interfaces

- ⚠ The available interfaces and pin mapping can differ depending on if ANNA-B112 is used with the u-connectXpress software or an open CPU based application. For detailed pin information see the ANNA-B112 data sheet [2].

1.8.1 Universal asynchronous serial interface (UART)

The ANNA-B112 module provides a Universal Asynchronous Serial Interface (UART) for data communication.

The following UART signals are available:

- Data lines (**RXD** as input, **TXD** as output)
- Hardware flow control lines (**CTS** as input, **RTS** as output)
- **DSR** and **DTS** are used to set and indicate system modes

The UART can be used as both 4 wire UART with hardware flow control and 2-wire UART with only **TXD** and **RXD**. If using the UART in 2-wire mode, **CTS** should be connected to GND on the ANNA-B112 module.

Depending on the bootloader used, the UART interface can also be used for software upgrade. See the Software section for more information.

The u-connectXpress software adds the **DSR** and **DTR** pins to the UART interface. These pins are not used as originally intended, but to control the state of the ANNA-B112 module. Depending on the current configuration, the **DSR** can be used to:

- Enter command mode
- Disconnect and/or toggle connectable status
- Enable/disable the rest of the UART interface
- Enter/wake up from the sleep mode

See the ANNA-B112 data sheet [2] for characteristic information about the UART interface.

| Interface | Default configuration |
|-----------|--|
| COM port | 115200 baud, 8 data bits, no parity, 1 stop bit, hardware flow control |

Table 8: Default settings for the COM port while using the u-connectXpress software

It is recommended to make the UART available either as test points or connected to a header for software upgrade.

The IO level of the UART will follow the VCC voltage and it can thus be in the range of 1.8 V and 3.6 V. If you are connecting the ANNA-B112 module to a host with a different voltage on the UART interface, a level shifter should be used.

1.8.2 Serial peripheral interface (SPI)

ANNA-B112 supports up to 3 serial peripheral interfaces that can operate in both master and slave modes with a maximum serial clock frequency of 8 MHz in both these modes. The SPI interfaces use the following 4 signals:

- SCLK
- MOSI
- MISO
- CS

When using the SPI interface in master mode, it is possible to use GPIOs as additional Chip Select (CS) signals to allow addressing of multiple slaves.

1.8.3 I2C interface

The Inter-Integrated Circuit (I2C) interfaces can be used to transfer or receive data on a 2-wire bus network. The ANNA-B112 module contains up to two I2C bus interfaces and can operate as both master and slave using both standard (100 kbps) and fast (400 kbps) transmission speeds. The interface uses the **SCL** signal to clock instructions and data on the **SDL** signal.

External pull up resistors are required for the I2C interface. The value of the pull up resistor should be selected depending on the speed and capacitance of the bus.

1.9 GPIO pins

The ANNA-B112 module can provide up to 25 pins, which can be configured as general purpose input or output. 8 GPIO pins are capable of handling analog functionality. All pins are capable of handling interrupt.

| Function | Description | Default ANNA-B1 pin | Configurable GPIOs |
|------------------------------|--|---------------------|--------------------|
| General purpose input | Digital input with configurable edge detection and interrupt generation. | | Any |
| General purpose output | Digital output with configurable drive strength, pull-up, pull-down, open-source, open-drain and/or slew rate. | | Any |
| Pin disabled | Pin is disconnected from input buffers and output drivers. | All* | Any |
| Timer/ counter | High precision time measurement between two pulses/ Pulse counting with interrupt/event generation. | | Any |
| Interrupt/ Event trigger | Interrupt/event trigger to the software application/ Wake up event. | | Any |
| ADC input | 8/10/12-bit analog to digital converter | | Any analog |
| Analog comparator input | Compare two voltages, capable of generating wake-up events and interrupts | | Any analog |
| PWM output | Output complex pulse width modulation waveforms | | Any |
| Connection status indication | Indicates if a BLE connection is maintained | BLUE** | Any |

* = If left unconfigured

** = If using u-connectXpress software

Table 9: GPIO custom functions configuration

1.9.1 Analog interfaces

8 out of the 25 digital GPIOs can be multiplexed to analog functions. The following analog functions are available for use:

- 1x 8-channel ADC
- 1x Analog comparator*
- 1x Low-power analog comparator*

*Only one of the comparators can be used simultaneously.

1.9.1.1 ADC

The Analog to Digital Converter (ADC) can sample up to 200 kHz using different inputs as sample triggers. Table 10 shows the sample speed in correlation to the maximum source impedance. It supports 8/10/12-bit resolution. Any of the 8 analog inputs can be used both as single-ended inputs and as differential pairs for measuring the voltage across them. The ADC supports full 0 V to VCC input range.

| ACQ [us] | Maximum source resistance [kΩ] |
|----------|--------------------------------|
| 3 | 10 |
| 5 | 40 |
| 10 | 100 |
| 15 | 200 |
| 20 | 400 |
| 40 | 800 |

Table 10: Acquisition versus source impedance

1.9.1.2 Comparator

The comparator compares voltages from any analog pin with different references as shown in Table 11. It supports full 0 V to VCC input range and can generate different software events to the rest of the system.

1.9.1.3 Low power comparator

The low-power comparator operates in the same way as the normal comparator, with reduced functionality. It can be used during system OFF modes as a wake-up source.

1.9.1.4 Analog pin options

The following table shows the supported connections of the analog functions.

 An analog pin may not be simultaneously connected to multiple functions.

| Analog function | Connects to |
|--------------------------|--|
| ADC single-ended input | Any analog pin or VCC |
| ADC differential input | Any analog pin or VCC pair |
| Comparator IN+ | Any analog pin |
| Comparator IN- | Pin 24 or 25, VCC, 1.2 V, 1.8 V, 2.4 V |
| Low-power comparator IN+ | Any analog pin |
| Low-power comparator IN- | Pin 24 or 25, 1/16 to 15/16 VCC in steps of 1/16 VCC |

Table 11: Possible uses of analog pin

1.10 Antenna interface

The ANNA-B112 is equipped with an integrated antenna in the module. Depending on how the RF pins are connected, the internal antenna can be bypassed and an external antenna can be used instead. Table 12 describes how the RF related pins shall be connected for each antenna solution.

| | External antenna | Integrated antenna module placed in the corner of the PCB | Integrated antenna module placed on the side of the PCB |
|-----------------|-----------------------------|---|---|
| Pin 1 – ANT_PCB | GND* | GND pattern | NC |
| Pin 2 – ANT_GND | GND | NC | GND pattern |
| Pin 3 – ANT_GND | GND | NC | GND pattern |
| Pin 5 – ANT_INT | GND* | Connect to pin 6 – ANT | Connect to pin 6 – ANT |
| Pin 6 – ANT | Connect to external antenna | Connect to pin 5 – ANT_INT | Connect to pin 5 – ANT_INT |

*Connect to GND for better layout, not critical for function

Table 12: ANNA-B112 Antenna options

1.10.1 Integrated antenna

The ANNA-B112 is equipped with a certified integrated antenna in the module. To take advantage of the ANNA-B112 certification, the customer is required to implement the specific ground plane design according to u-blox reference design. The reference design is described in Appendix B.

1.10.2 Antenna pin (external antenna)

The ANNA-B112 is equipped with an RF pin. The RF pin has a nominal characteristic impedance of 50 Ω and must be connected to the antenna through a 50 Ω transmission line to allow reception of radio frequency (RF) signals in the 2.4 GHz frequency band.

Choose an antenna with optimal radiating characteristics for the best electrical performance and overall module functionality. An internal antenna integrated on the application board, or an external antenna connected to the application board through a proper 50 Ω connector, can be used.

While using an external antenna, the PCB-to-RF-cable transition must be implemented using either a suitable 50 Ω connector, or an RF-signal solder pad (including GND) that is optimized for 50 Ω characteristic impedance.

1.10.2.1 Antenna matching

The antenna return loss should be as good as possible across the entire band when the system is operational to provide optimal performance. The enclosure, shields, other components and surrounding environment will impact the return loss seen at the antenna port. Matching components are often required to re-tune the antenna to bring the return loss within an acceptable range.

It is difficult to predict the actual matching values for the antenna in the final form factor. Therefore, it is a good practice to have a placeholder in the circuit with a “pi” network, with two shunt components and a series component in the middle, to allow maximum flexibility while tuning the matching to the antenna feed.

1.10.2.2 Approved antenna designs

ANNA-B112 module comes with a pre-certified design that can be used to save costs and time during the certification process. The antenna path is routed to a U.FL connector and the external antenna is connected to the U.FL connector.

To take advantage of the ANNA-B112 certification, the customer is required to implement antenna layout according to u-blox reference design. The reference design is described in Appendix B.

The designer integrating a u-blox reference design into an end-product is solely responsible for the unintentional emission levels produced by the end-product.

The module may be integrated with other antennas. In this case, the OEM installer must certify his design with respective regulatory agencies.

1.10.3 NFC antenna

The ANNA-B112 module includes a Near Field Communication interface, capable of operating as a 13.56 MHz NFC tag at a bit rate of 106 kbps. As an NFC tag, data can be read from or written to the ANNA-B112 modules using an NFC reader; however, the ANNA-B112 module is not capable of reading other tags or initiating NFC communications. Two pins are available for connecting to an external NFC antenna: **NFC1** and **NFC2**.

1.11 Reserved pins (RSVD)

Do not connect reserved (**RSVD**) pin. The reserved pins can be allocated for future interfaces and functionality.

1.12 GND pins

Good connection of the module's GND pins with solid ground layer of the host application board is required for correct RF performance. It significantly reduces EMC issues and provides a thermal heat sink for the module.

See the Module footprint and paste mask and thermal guidelines sections for information about ground design.

2 Software

The ANNA-B112 module can be used either with the preflashed u-connectXpress software or as an Open CPU module where you can run your own application developed either with for example Arm Mbed, Nordic SDK or Wirepas Mesh development environment inside the ANNA-B112 module.

The software on the ANNA-B112 module contains of the following parts:

- SoftDevice S132 is a Bluetooth low energy (Bluetooth LE) central and peripheral protocol stack solution
- Optional bootloader
- Application

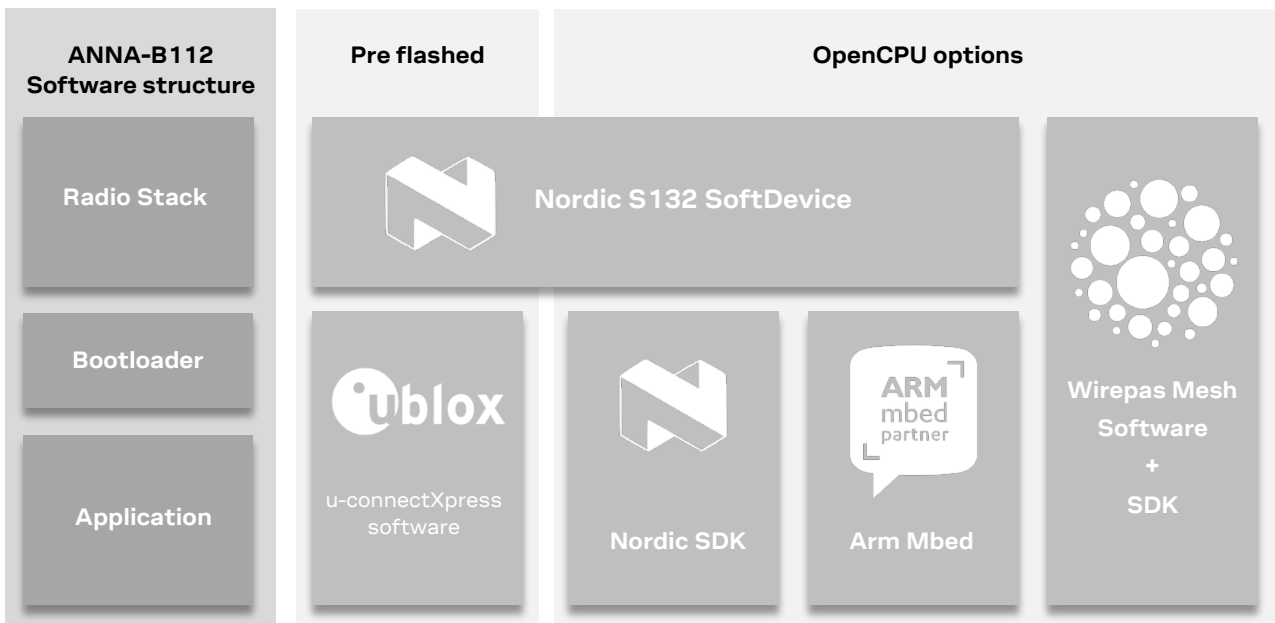

Figure 3: ANNA-B1 software structure and available software options

2.1 u-connectXpress software

2.1.1 Standard edition

The ANNA-B112-0XB module is delivered with the preflashed u-connectXpress software.

The u-connectXpress software enables the use of the Bluetooth Low Energy functions, controlled by AT-commands over the UART interface. Examples of supported features are u-blox Low Energy Serial Port Service, GATT server and client, central and peripheral roles and multidrop connections. More information on the features and capabilities of the u-connectXpress software and how to use it can be found in the u-connectXpress software user guide [3] and u-connect AT commands manual [4].

2.1.2 Mesh edition

u-ConnectXpress is also available in a separated edition available for download. For more information about the mesh SW please refer to the application note Bluetooth Mesh with u-connect software [21].

2.2 Open CPU

2.2.1 Nordic nRF5 SDK

The Nordic nRF5 SDK provides a rich development environment for different devices and applications by including a broad selection of drivers and libraries. The SDK is delivered as a plain .zip-archive, which makes it easy to install. The SDK comes with support for Segger Embedded Studio, Keil μ Vision, GCC make files, and IAR support, which gives the freedom to choose the IDE and compiler.

2.2.1.1 Getting started with the Nordic nRF5 SDK

When working with the Nordic SDK on the ANNA-B112 module, follow the steps below to get started with the Nordic Semiconductor toolchain and examples:

1. Download and install the nRF Connect application and install the Programmer app, which allows programming over SWD, from www.nordicsemi.com. Also other SWD capable programmers can be used.
2. Download and install the latest SEGGER Embedded Studio from www.segger.com, or use another supported IDE.
3. Download and extract the latest nRF5 SDK available at: <http://www.nordicsemi.com/eng/Products/Bluetooth-low-energy/nRF5-SDK>. Save the software container to the directory you want to use with the nRF5 SDK.
4. Read the information in the SDK Release Notes and check the nRF5 Software Development Kit documentation available at the Nordic Semiconductor Infocenter [13].

The easiest way to get started with the Nordic SDK is to copy one of the examples in the SDK to get started. Choose the example that is the closest to what you want to achieve and use the board definition that is the closest to your board. If you are building for ANNA-B1 the closest board definition is the *pca10040*.

2.2.1.2 Create a custom board for Nordic nRF5 SDK

The predefined hardware boards included in the Nordic SDK are Nordic development boards only. To add support for a custom board, a custom board support file can be created. This is normally located in the folder `...\components\boards\` or together with the `sdk_config .h` file in the `config` folder of the example.

The above-mentioned file locations are valid according to the Nordic nRF5 SDK version 17.0.

Figure 4 shows an example of how the custom board support file can look like for EVK-ANNA-B112.

```

#ifndef BOARD_CUSTOM_H
#define BOARD_CUSTOM_H

#ifdef __cplusplus
extern "C" {
#endif

#include "nrf_gpio.h"

// In this case PIN 25 is used as button SW1, if the green led
// should be used it is possible to defined that one instead.
#define LEDS_NUMBER 2

#define LED_1 27 // Red
#define LED_2 26 // Blue
// #define LED_3 25 // Green

#define LEDS_ACTIVE_STATE 0

#define LEDS_LIST { LED_1, LED_2 }

#define BSP_LED_0 LED_1
#define BSP_LED_1 LED_2

#define LEDS_INV_MASK LEDS_MASK

#define BUTTONS_NUMBER 2

#define BUTTON_1 25 // SW1
#define BUTTON_2 24 // SW2
#define BUTTON_PULL NRF_GPIO_PIN_PULLUP

#define BUTTONS_ACTIVE_STATE 0

#define BUTTONS_LIST { BUTTON_1, BUTTON_2 }

#define BSP_BUTTON_0 BUTTON_1
#define BSP_BUTTON_1 BUTTON_2

#define RX_PIN_NUMBER 2
#define TX_PIN_NUMBER 3
#define CTS_PIN_NUMBER 19
#define RTS_PIN_NUMBER 11
#define HWFC true

// Low frequency clock source to be used by the SoftDevice
#define NRF_CLOCK_LFCLKSRC { .source = NRF_CLOCK_LF_SRC_XTAL, \
                             .rc_ctiv = 0, \
                             .rc_temp_ctiv = 0, \
                             .xtal_accuracy = NRF_CLOCK_LF_XTAL_ACCURACY_20_PPM}

#ifdef __cplusplus
}
#endif

#endif // BOARD_CUSTOM_H

```

Figure 4: Example of EVK-ANNA-B112 custom board support file

This board file can also be downloaded from the u-blox shortrange open CPU github repository [17].

To make the build system use your custom board file define the build variable `BOARD_CUSTOM` in the build configuration. If you build on an existing example, undefine the default `BOARD_PCA10040`.

2.2.1.3 Adding the board configuration to your project

A flexible way of adding a board to your project is to add a new build configuration to your Segger Studio project and then use this configuration to select the correct board file for your build. By adding several configurations, you can build for several targets from the same Segger Studio project. For example, you can use the following procedure to build from both your custom board and u-blox EVK to test your code on different platforms:

1. Add a build configuration in the Segger Studio project

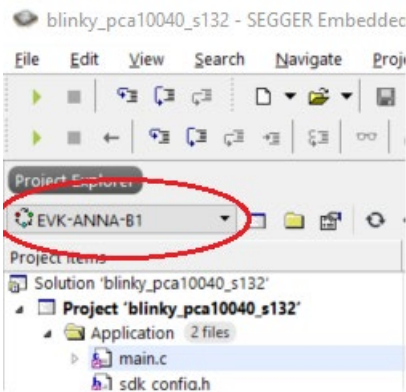

Figure 5 Add a build configuration to Segger Studio

2. Configure the build configuration to use your board definition. Remember to undefine the configuration for the original board, assuming you are basing your project on an example from the Nordic nRF5 SDK.

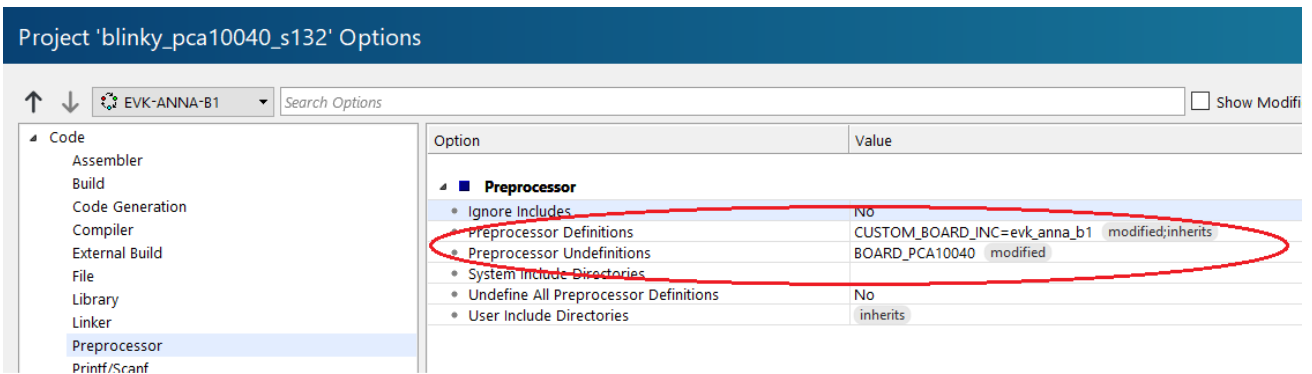
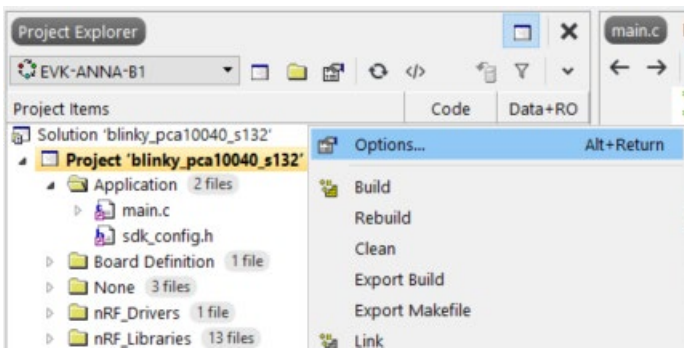

Figure 6: Setting up board configuration to use `evk_anna_b1.h` board file.

The build for your configuration now uses your custom board file.

2.2.2 Zephyr

Zephyr [16] is a widely adopted open-source Real Time Operating System (RTOS) that is supported on a multitude of chipsets, including the nRF52832 chip in the ANNA-B1 module. The Zephyr project is supported by the Linux Foundation.

Nordic Semiconductor provides the nRF Connect SDK for development using the Zephyr OS, but it is also possible to use a command-line environment for example.

2.2.2.1 Getting started with Zephyr on the ANNA-B1 module

Follow the procedure below to get started with Zephyr:

1. Install the Toolchain Manager from the *nRF Connect for Desktop* application and from there install the nRF Connect SDK. For more information, see reference [20].
2. If a command line environment is preferred, refer to the Getting Started section on the Zephyr website [16] for more information.

2.2.2.2 Defining a board configuration in Zephyr

The Zephyr OS is similar to Linux and uses a similar structure of make files and config files as the Linux kernel. It also uses a device tree file to set up the pin mapping for your board.

Although an example configuration for EVK-ANNA-B1 is not yet included in the Zephyr distribution, the configuration can be downloaded from the u-blox shortrange open CPU github repository [17].

You can copy the configuration to the `<install directory>/zephyr/boards/arm` folder and the build the project from your preferred environment.

2.2.2.3 Building for the ANNA-B1 EVK using nRF Connect SDK

To build the blinky sample using the nRF Connect SDK, open the sample shown in Figure 7. You can then build and flash it from within Segger Studio.

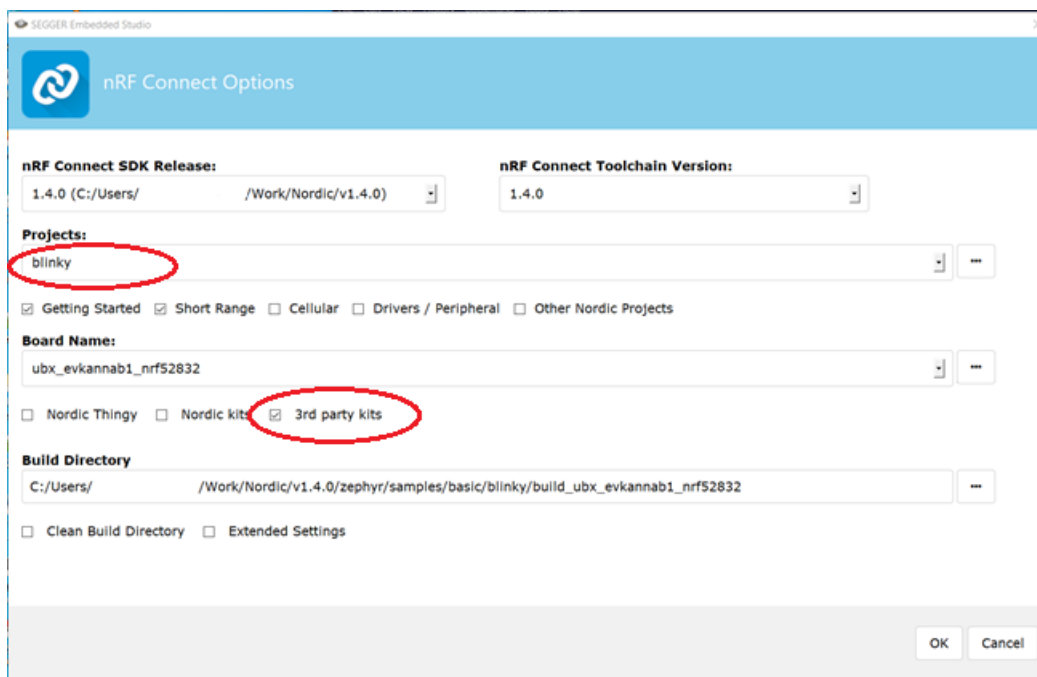

Figure 7 Opening blinky sample for the ANNA-B1 EVK

2.2.2.4 Building for ANNA-B1 EVK using the Zephyr command-line environment

To build and flash the 'blinky' example from Zephyr for the ANNA-B1 EVK, move to the zephyr folder in your installation and on the shell prompt enter:

```
~/zephyrproject/zephyr$ west build -b ubx_evkannab1_nrf52832 samples/basic/blinky
~/zephyrproject/zephyr$ west flash
```

The example board configuration also contains some documentation files that can be included in your local documentation. The files are in reStructuredText format. For information on how to generate HTML or PDF output from these files, refer to the Zephyr Project documentation [18].

2.2.2.5 Low Frequency clock source configuration

An external 32 kHz crystal oscillator is the default low-frequency clock source chosen for nRF52832-based boards in Zephyr OS. The clock source can be changed by changing the kernel configuration options:

- `CLOCK_CONTROL_NRF_SOURCE`
- `CLOCK_CONTROL_NRF_ACCURACY`

Refer to the Zephyr project documentation [18] for up-to-date information about these options.

2.2.3 Support – Nordic development forum

For support related to the Nordic nRF5 SDK or nRF Connect SDK, refer to the Nordic development zone website at: <https://devzone.nordicsemi.com/>.

2.2.4 Arm Mbed OS

Arm Mbed OS is an open-source embedded operating system designed specifically for the "things" in IoT (Internet of Things). It includes all the features to develop a connected product, including security, connectivity, RTOS, and drivers for sensors and I/O devices. With an RTOS core based on the widely used open-source CMSIS-RTOS RTX, Arm Mbed OS supports deterministic, multithreaded, real time software execution. Arm Mbed OS has native support for building across the Arm Compiler 5, GCC, and IAR compiler toolchains.

2.2.4.1 Getting started with the Arm Mbed OS

A list of prerequisites for getting started with Arm Mbed OS 5 development on EVK-ANNA-B112 is available at <https://github.com/ARMmbed/mbed-os-example-ble#getting-started>.

Mbed CLI is the name of the Arm Mbed command line tool that enables the full Mbed workflow. You can use the tool to control repository versions, maintain dependencies, update from remotely hosted repositories (GitHub, GitLab and mbed.org), and invoke Arm Mbed's own build system.

Documentation describing the installation and usage of the Mbed CLI is available at <https://github.com/ARMmbed/mbed-cli#introduction>.

Section 2.2.3.2 describes how to create a build target for EVK-ANNA-B112.

Bluetooth low energy examples from Arm Mbed are available at: <https://github.com/ARMmbed/mbed-os-example-ble>.

2.2.4.2 Create a custom target for Arm Mbed

Add target

Add a new JSON object to the `targets.json` file located in the `\mbed-os\targets\` folder.

Figure 8 shows an example of the JSON object for EVK-ANNA-B112. For a list of the known properties in the Arm Mbed build system, see “Standard properties” in reference [5].

The location of the `targets.json` is the same as that in Arm Mbed OS release 5.6.

```

"UBLOX_EVK_ANNA_B112": {
  "supported_form_factors": ["ARDUINO"],
  "inherits": ["MCU_NRF52"],
  "macros_add": [
    "BOARD_PCA10040",
    "NRF52_PAN_12",
    "NRF52_PAN_15",
    "NRF52_PAN_58",
    "NRF52_PAN_55",
    "NRF52_PAN_54",
    "NRF52_PAN_31",
    "NRF52_PAN_30",
    "NRF52_PAN_51",
    "NRF52_PAN_36",
    "NRF52_PAN_53",
    "S132",
    "CONFIG_GPIO_AS_PINRESET",
    "BLE_STACK_SUPPORT_REQD",
    "SWI_DISABLE0",
    "NRF52_PAN_20",
    "NRF52_PAN_64",
    "NRF52_PAN_62",
    "NRF52_PAN_63"],
  "device_has_add": [
    "ANALOGIN",
    "I2C",
    "I2C_ASYNC",
    "INTERRUPTIN",
    "LOWPOWERTIMER",
    "PORTIN",
    "PORTINOUT",
    "PORTOUT",
    "PWMOUT",
    "RTC",
    "SERIAL",
    "SERIAL_ASYNC",
    "SLEEP",
    "SPI",
    "SPI_ASYNC",
    "SPISLAVE",
    "FLASH"],
  "release_versions": ["2", "5"],
  "device name": "nRF52832 xxAA"
}
    
```

Figure 8: Example of EVK-ANNA-B112 target object

Pin mapping

Create a folder with the same name as the JSON object added (above) previously. The folder should be located at `\mbed-os\targets\TARGET_NORDIC\TARGET_NRF5\TARGET_MCU_NRF52832\`.

For EVK-ANNA-B1, the folder is called `TARGET_UBLOX_EVK_ANNA_B112`.

In this new folder, there should be two files, `device.h` and `PinNames.h`.

1. `device.h` contains the `#include` object.h shown in Figure 9.

```

#ifndef MBED_DEVICE_H
#define MBED_DEVICE_H

#include "objects.h"

#endif
    
```

Figure 9: Example code for `device.h`

2. `PinNames.h` should declare and define a couple of enumerations to configure the custom pin mapping. Figure 6 and Figure 7 show the contents of the `PinNames.h` file for EVK-ANNA-B112.

```

#ifndef MBED_PINNAMES_H
#define MBED_PINNAMES_H

#include "cmsis.h"

#ifdef __cplusplus
extern "C" {
#endif

    typedef enum {
        PIN_INPUT,
        PIN_OUTPUT
    } PinDirection;

#define PORT_SHIFT 3

    typedef enum {
        // nRF52 pin names
        p0 = 0,
        p1 = 1,
        p2 = 2,
        p3 = 3,
        p4 = 4,
        p5 = 5,
        p6 = 6,
        p7 = 7,
        p8 = 8,
        p9 = 9,
        p10 = 10,
        p11 = 11,
        p12 = 12,
        p13 = 13,
        p14 = 14,
        p15 = 15,
        p16 = 16,
        p17 = 17,
        p18 = 18,
        p19 = 19,
        p20 = 20,
        p21 = 21,
        p22 = 22,
        p23 = 23,
        p24 = 24,
        p25 = 25,
        p26 = 26,
        p27 = 27,
        p28 = 28,
        p29 = 29,
        p30 = 30,
        p31 = 31,
    }

```

Figure 10: `PinNames.h` - Example code for EVK-ANNA-B112

```

//ANNA-B112 module pin names
ANNA_B112_IO_13 = p14,
ANNA_B112_IO_14 = p15,
ANNA_B112_IO_15 = p16,
ANNA_B112_IO_16 = p18,
ANNA_B112_IO_17 = p0,
ANNA_B112_IO_18 = p1,
ANNA_B112_IO_19 = p3,
ANNA_B112_IO_20 = p2,
ANNA_B112_IO_21 = p9,
ANNA_B112_IO_22 = p10,
ANNA_B112_IO_23 = p5,
ANNA_B112_IO_24 = p4,
ANNA_B112_IO_25 = p31,
ANNA_B112_IO_26 = p30,
ANNA_B112_IO_27 = p29,
ANNA_B112_IO_28 = p28,
ANNA_B112_IO_29 = p27,
ANNA_B112_IO_30 = p25,
ANNA_B112_IO_31 = p26,

ANNA_B112_IO_34 = p11,
ANNA_B112_IO_35 = p19,
ANNA_B112_IO_36 = p22,
ANNA_B112_IO_37 = p23,
ANNA_B112_IO_38 = p24,

ANNA_B112_IO_45 = p20,

// EVK-ANNA-B112 board
LED1 = ANNA_B112_IO_29, // Red
LED2 = ANNA_B112_IO_30, // Green/SW1
LED3 = ANNA_B112_IO_31, // Blue
LED4 = NC,

SW1 = ANNA_B112_IO_30,
SW2 = ANNA_B112_IO_38,

D0 = ANNA_B112_IO_20,
D1 = ANNA_B112_IO_19,
D2 = ANNA_B112_IO_35,
D3 = ANNA_B112_IO_34,
D4 = ANNA_B112_IO_29,
D5 = ANNA_B112_IO_31,
D6 = ANNA_B112_IO_22,
D7 = ANNA_B112_IO_21,

D8 = ANNA_B112_IO_13,
D9 = ANNA_B112_IO_38,
D10 = ANNA_B112_IO_36,
D11 = ANNA_B112_IO_37,
D12 = ANNA_B112_IO_16,
D13 = ANNA_B112_IO_45,

D14 = ANNA_B112_IO_14,
D15 = ANNA_B112_IO_15,

A0 = ANNA_B112_IO_24,
A1 = ANNA_B112_IO_23,
A2 = ANNA_B112_IO_28,
A3 = ANNA_B112_IO_27,
A4 = ANNA_B112_IO_26,
A5 = ANNA_B112_IO_25,

// Nordic SDK pin names
RX_PIN_NUMBER = p2,
TX_PIN_NUMBER = p3,
CTS_PIN_NUMBER = p19,
RTS_PIN_NUMBER = p11,

```

Figure 11: PinNames.h example code for EVK-ANNA-B112 (continued)

```
typedef enum {
    PullNone = 0,
    PullDown = 1,
    PullUp = 3,
    PullDefault = PullUp
} PinMode;

#ifdef __cplusplus
}
#endif
#endif
```

Figure 12: PinNames.h example code for EVK-ANNA-B112 (continued)

Build software

In the Arm Mbed CLI, compile software by using the name of the object created in the `targets.json` file as a parameter to the board flag. For the EVK-ANNA-B112 example, use the build command:

```
mbed compile -t GCC_ARM -m UBLOX_EVK_ANNA_B112
```

2.2.5 Wirepas Mesh

ANNA-B112 can also be used together with the Wirepas Mesh software stack. This allows ANNA-B112 to be used in a true, large-scale, mesh environment.

Wirepas Mesh is third party software licensed from Wirepas.

For more information about Wirepas Mesh software, contact your local u-blox support team.

2.2.6 Saving Bluetooth MAC address and other production data

ANNA-B112-0XB comes with a Bluetooth MAC address programmed. See also section 2.3.2.2. This address is used by the customer application – if needed.

ANNA-B112-70B module comes with an empty flash.

The MAC address is programmed in the CUSTOMER[0] and CUSTOMER[1] user information configuration registers of the of the nRF52832 chip. The address can be read and written using either Segger J-Link utilities or the Nordic `nrfjprog` utility.

```
$ nrfjprog.exe --memrd 0x10001080 --n 8
```

The memory area can be saved and, if the flash is erased, later written back using the `savebin` and `loadbin` utilities in the Segger J-link tool suite.

UICR (user information configuration registers) memory also holds the serial number and other information that can be useful to save. If you want to save and restore the whole memory area, you use the commands:

```
$ nrfjprog.exe --readuicr uicr.hex
...
$ nrfjprog.exe --program uicr.hex
```

 Note that the user information configuration registers hold the boot loader start address, which can confuse the boot process during open CPU development. In this instances, the MAC address must be written separately.

For additional information and instructions on saving and using the public Bluetooth device address, see reference [14].

2.3 Flashing ANNA-B112

It is possible to reflash ANNA-B112 using either the UART or SWD interface whenever a new version of the u-connectXpress software is available. ANNA-B112-70B module variants do not have any software preloaded and must be flashed over SWD.

-  Flashing of u-connectXpress software is normally done over UART. If the flash is erased or any other software is flashed on ANNA-B112, the SoftDevice and the u-blox bootloader must be flashed over SWD before the u-connectXpress software can be flashed over UART again. See section 2.3.2 for more information.

Open CPU software is flashed over the SWD interface.

2.3.1 Flashing over UART

To use the UART interface, the module must have a bootloader that supports flashing over UART. The u-connectXpress software includes a bootloader that can flash the u-connectXpress software over UART.

The u-connectXpress software for UART flashing contains two separate binary files and one json file:

1. `s132_nrf52_x.x.x_softdevice.bin` contains the SoftDevice.
2. `ANNA-B112-SWx.x.x.bin` contains the application.
3. `ANNA-B112-Configuration-x.x.x.json` contains the bin file name, flash address, size, and crc for the SoftDevice. It also includes the bin file name and the flash address for the application.

The XMODEM protocol is used for flashing. Flow control is not used. The following pins should be made available as either headers or test points to flash the module:

- **UART** (RX, TX)
- **RESET_N**
- **SWITCH_1** and **SWITCH_2**

2.3.1.1 s-center

 Flashing of u-connectXpress software requires s-center software version 4.2.0 or later.

To flash the module using s-center:

1. Select **Tools > Software Update** as shown in the following screenshot:

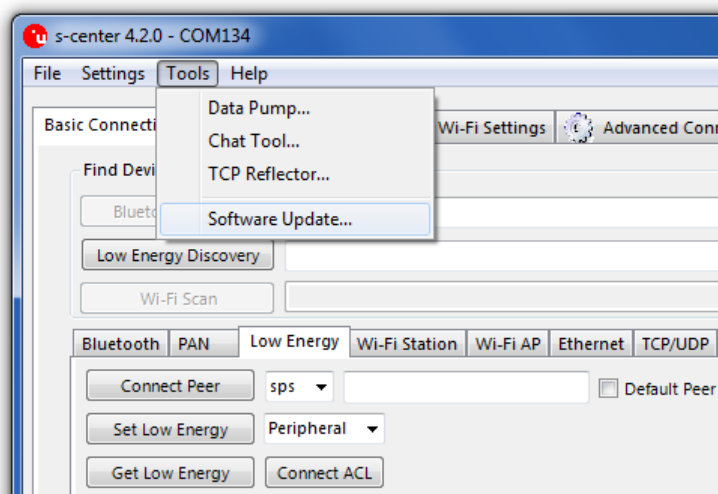

2. Select the json file.

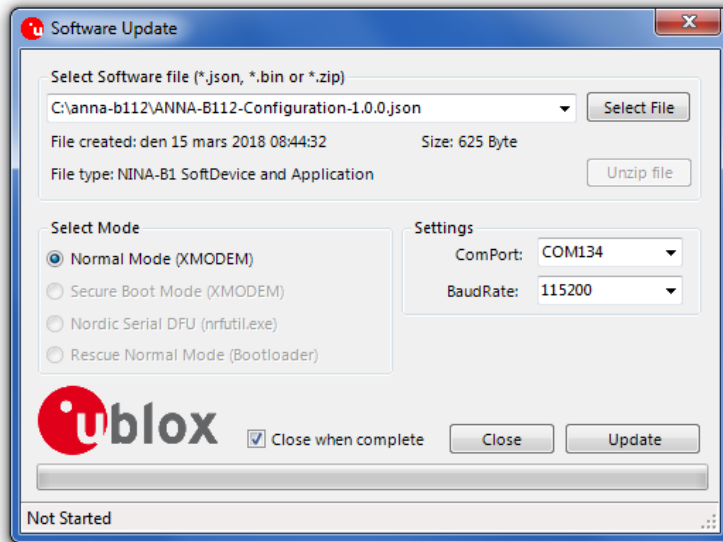

3. Set the correct COM port, ensure that the Normal Mode is selected, and select **Update**. The module reboots into the bootloader and the flashing of the SoftDevice and application starts.

2.3.1.2 Terminal application

The bootloader included in the u-connectXpress software supports the XMODEM protocol

Flashing the SoftDevice

Follow the procedure below to flash the SoftDevice using a terminal application.

1. Connect to the module using Tera Term, and set the serial settings as shown in Figure 13.

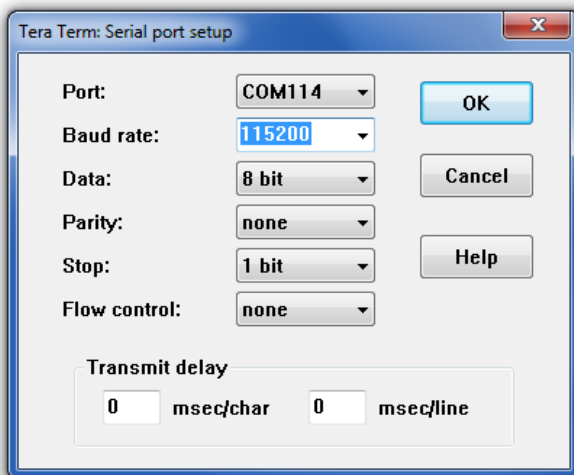

Figure 13: Screenshot that shows serial settings

2. Start the bootloader mode using either of the following methods:
 - a. AT command `AT+UFWUPD=1,115200`. See also u-connect AT commands manual [4].
 - b. Press the SW1 and SW2 buttons during the module reset
The bootloader prompt ">" is displayed when the bootloader mode has started.



The bootloader times out and resumes the application after 10 seconds.

3. The command `x [SoftDevice address]` sets the bootloader in file transfer mode. The address can be found in the json configuration file included in the software package.

```
{  
  "Label": "SoftDevice",  
  "Description": "Softdevice from NordicSemi",  
  "File": "s132_nrf52_5.0.0_softdevice.bin",  
  "Version": "s132_nrf52_5.0.0_softdevice",  
  "Address": "0x0",  
  "Size": "0x224A8",  
  "Crc32": "0xAB70DDB4"  
}
```

Figure 14: Example of SoftDevice information from the json configuration file

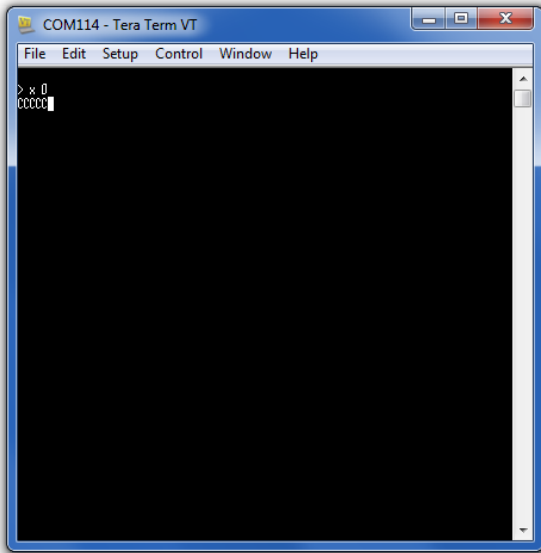

Figure 15: Screenshot that shows file transfer mode

4. When the bootloader displays “ccc” (see also Figure 15), it is ready to receive the SoftDevice bin file. Send the file using the XMODEM protocol.

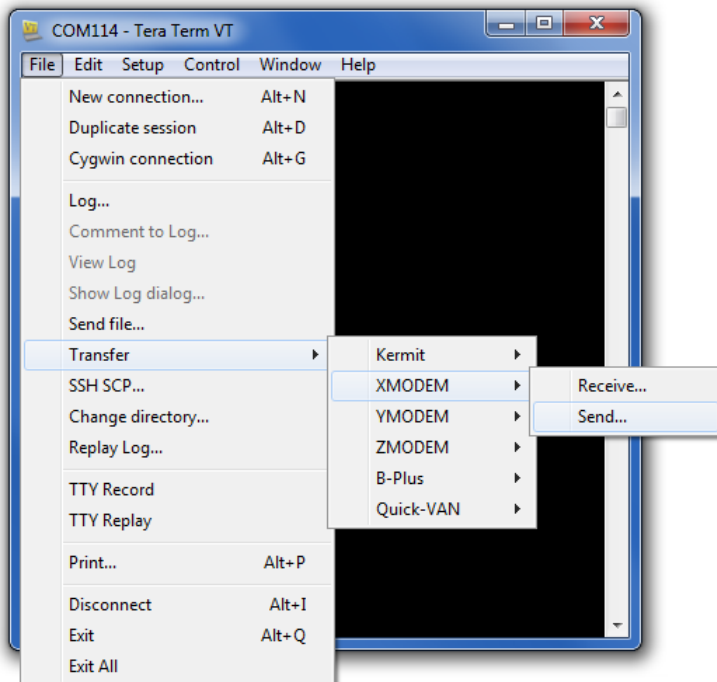

Figure 16: Screenshot that shows how to send the file using XMODEM protocol

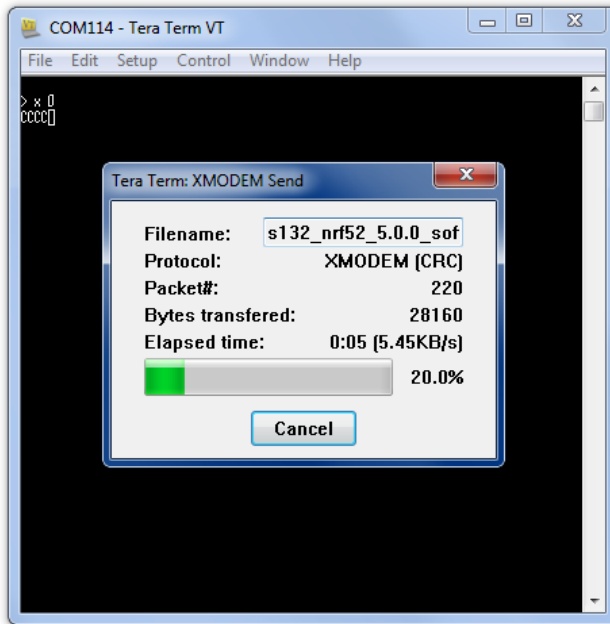

Figure 17: Screenshot shown during file transfer

5. An OK response indicates a successful file transfer.

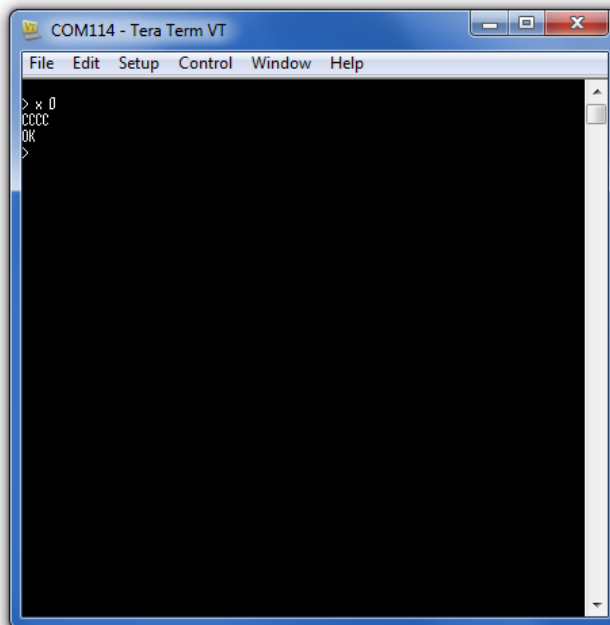

Figure 18: Screenshot shown on successful file transfer

6. Verify the transferred file using the command:
`c SOFTDEVICE [SoftDevice size] [SoftDevice CRC32]`

The size and crc can be found in the json configuration file, as shown in Figure 19.

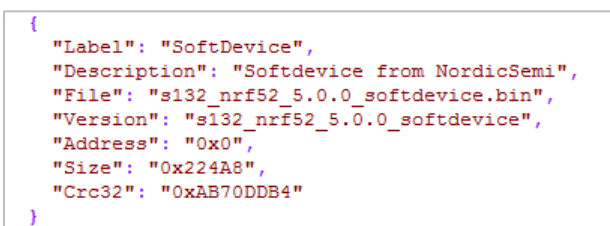

Figure 19: SoftDevice information example from the json configuration file

7. An OK response indicates a successfully flashed SoftDevice.

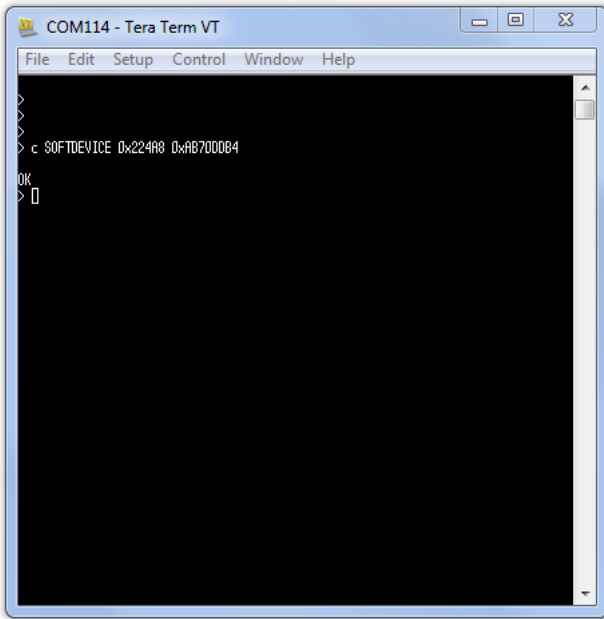

Figure 20: Screenshot shown on successful verification of the transferred file

Flashing the application software

1. Use command `x [Application address]` to set the bootloader in file transfer mode. The application address can be found in the json configuration file.

```
{  
  "Label": "ConnectivitySoftware",  
  "Description": "ANNA-B112 Firmware",  
  "File": "ANNA-B112-FW1.0.0-001.bin",  
  "Version": "ANNA-B112-FW1.0.0-001",  
  "Address": "0x23000"  
},
```

Figure 21: Example of application information from the json configuration file

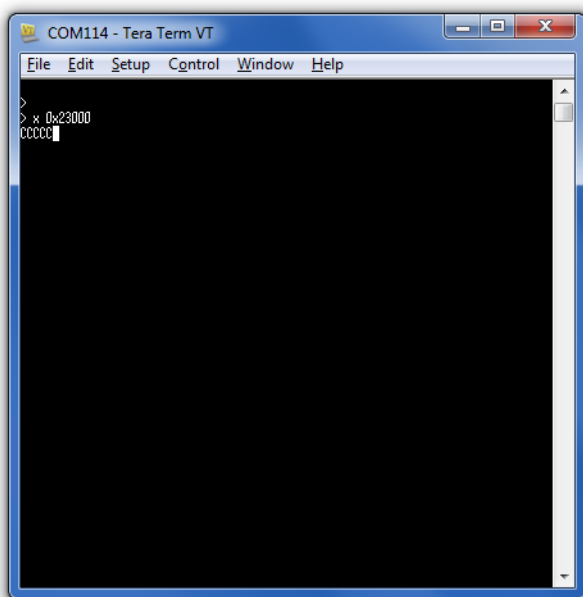

Figure 22: Screenshot shown on file transfer mode

- When the bootloader displays `ccc`, as shown in Figure 24, it is ready to receive the application bin file.

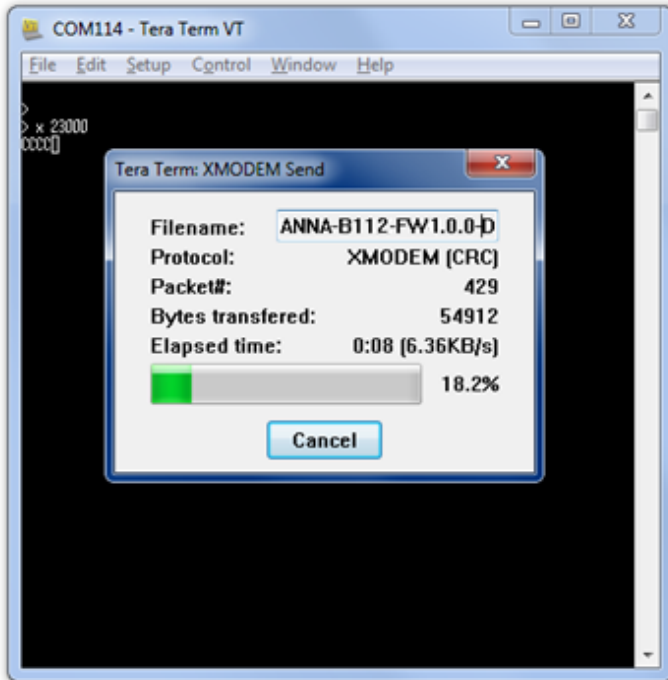

Figure 23: Screenshot shown during file transfer

- Send the file using the XMODEM protocol, as shown in Figure 23 .

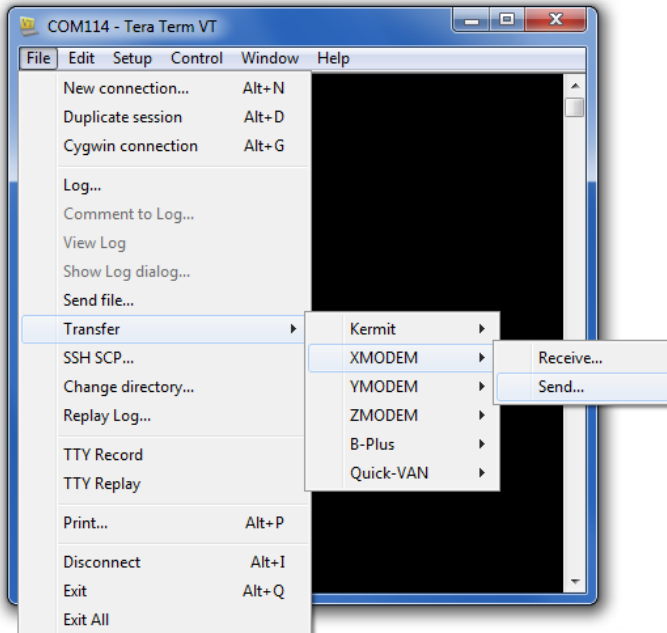

Figure 24: Screenshot showing how to send the file using XMODEM protocol

- An `OK` response indicates a successful file transfer. The application software does not require verification of the size and crc

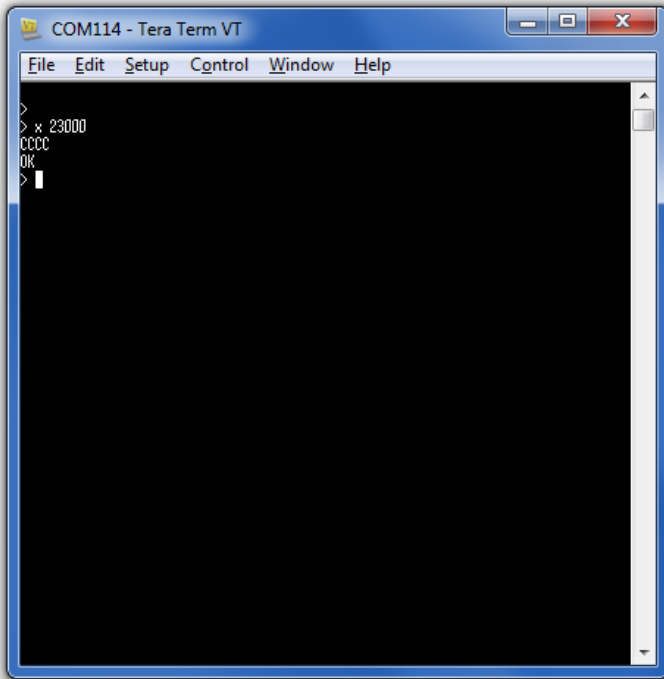



Figure 25: Screenshot shown on successful file transfer

5. Power cycle the module to start the u-connectXpress software.

2.3.2 Flashing over the SWD interface

For SWD (Serial Wire Debug) flashing, an external debugger must be connected to the SWD interface of the ANNA-B112 module. Then, use an external tool such as J-flash or the nRF Connect Programmer from Nordic Semiconductor to flash the module.

-  The external debugger SEGGER J-Link BASE is verified to work with ANNA-B112.
-  The EVK-ANNA-B112 evaluation kit incorporates an on-board debugger and can therefore be flashed without any external debugger.

2.3.2.1 Flashing the software

-  If the UICR region is erased when flashing the software using the SWD interface, the Bluetooth device address is also erased. In these instances, the Bluetooth device address must be manually rewritten to the module after flashing. Ensure that you make a note of your Bluetooth device address before continuing with the flashing procedure. See section 2.3.2.2 for additional information.

In the nRF Connect Programmer, drag and drop the hex files you want to program into the GUI as shown in the following screenshot:

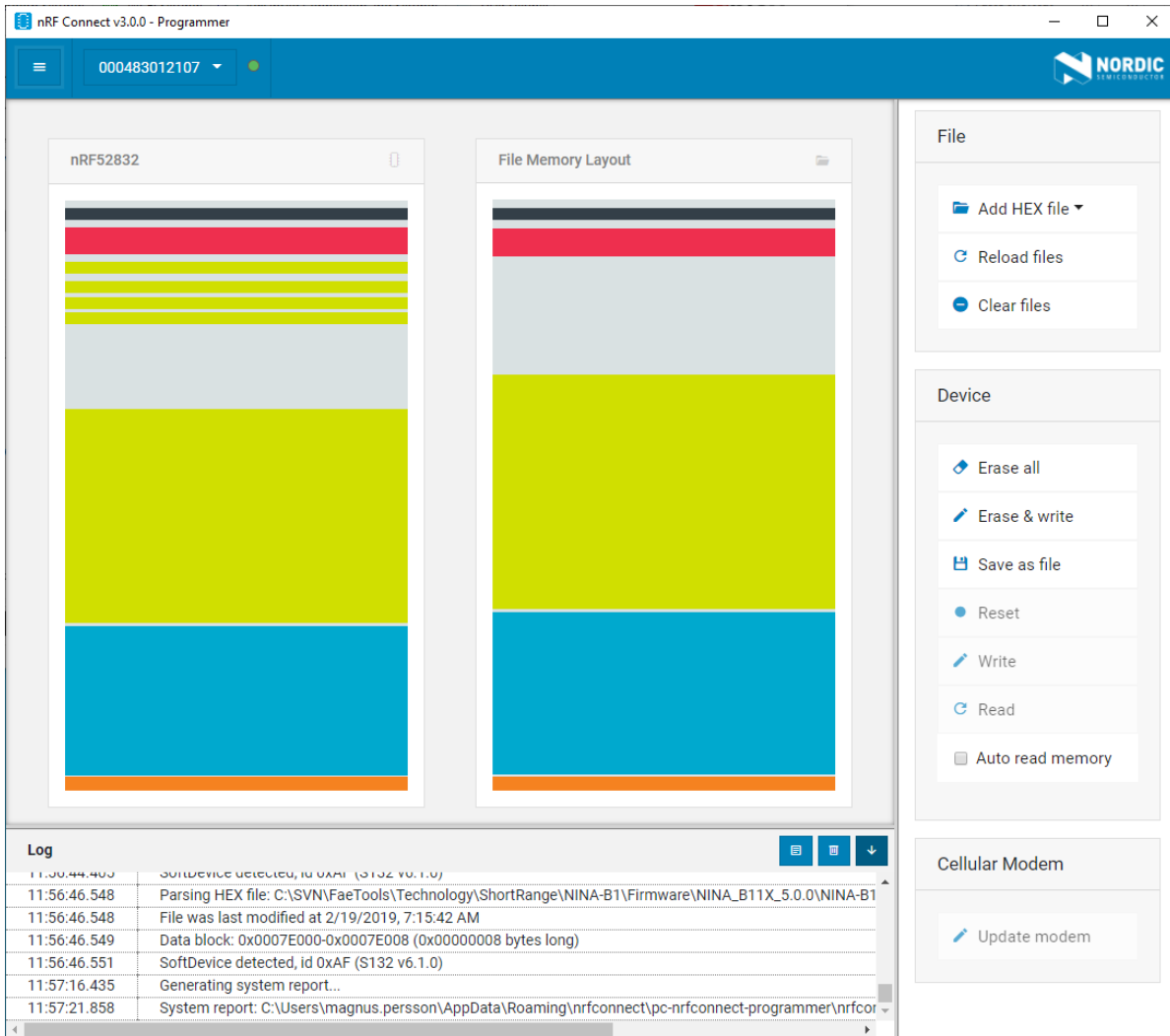

To reflash the u-connectXpress software, flash the following files:

- SoftDevice
- Bootloader – if applicable
- Application
- u-connectXpress software validation file – if applicable

In software deliveries on the u-blox webpage, the following .hex files are available for u-connectXpress software:

- **SoftDevice:** s132_nrf52_xxx.hex
- **Bootloader:** ANNA-B112_BOOT_xxx.hex
- **Application:** ANNA-B112_SW_xxx.hex
- **u-connectXpress software validation file:** valid_s132_nrf52_xxx_softdevice.hex

When developing and flashing open CPU applications, choose **Erase all** to remove the u-connectXpress software and associated parameters before flashing the custom application. Alternatively use the ANNA-B112-70B module version.

When the new u-connectXpress software has been flashed, remember to restore the Bluetooth device address if necessary. See also section 2.3.2.3.

2.3.2.2 Reading the Bluetooth device address

Flashing the software can erase the Bluetooth device address, which must then be manually rewritten to the module after flashing. Make a note of your Bluetooth device address before continuing with the flashing procedure.

The Bluetooth device address of your module can be accessed in either of the two ways described in the following subsections:

2.3.2.2.1 AT command

If your product device is operational and running u-connectXpress software, execute the following command to read the Bluetooth device address. The command response, including the device address, is shown here in **bold**:

```
AT+UMLA=1
+UMLA: D4CA6EB00613
OK
```

2.3.2.2.2 nrfjprog command line utility

You can also read the MAC address stored in the flash memory. To read or restore this address use the `nrfjprog` utility, as described in section 2.2.5.

2.3.2.3 Restoring the Bluetooth device address

When the new u-connectXpress software has been flashed to the module, it is important to restore the Bluetooth device address.

Step 1:

To enable writing of the Bluetooth device address, execute the following command and wait for the startup event:

```
AT+UPROD=1
OK
+STARTUP
```

Step 2:



To write your Bluetooth device address to the flash memory of the device and reset the device, execute the following commands (Bluetooth device address is marked in **bold** below, replace with your own):

```
AT+UPRODPW=1, D4CA6EB00613
OK
AT+CPWROFF
OK
+STARTUP
```

Step 3:

Verify that you have successfully written your Bluetooth Device address to the device using the following command:

```
AT+UMLA=1
+UMLA: D4CA6EB00613
OK
```

-  The Bluetooth device address will be permanently stored. The only way to rewrite the Bluetooth device address (in case of a mistake) is to repeat the SWD flashing procedure, as in section 2.3.2.1.
-  Failing to restore the Bluetooth device address may cause some u-connectXpress functionality to fail.

3 Design-in

3.1 Overview

For an optimal integration of ANNA-B112 in the final application board, it is advisable to follow the design guidelines stated in this section. Every application circuit must be properly designed to guarantee the correct functionality of the related interface; however, a number of points require a high level of attention during the design of the application device.

The following list provides important points sorted by rank of importance in the application design, starting from the highest relevance:

1. Module antenna connection:
2. Antenna circuit affects the RF compliance of the device integrating ANNA-B112 module with applicable certification schemes. Follow the recommendations provided in section 3.2 for schematic and layout design.
3. Module supply: **VCC**, and **GND** pins.
4. The supply circuit affects the performance of the device integrating ANNA-B112 module. Follow the recommendations provided in section 3.3 for schematic and layout design.
5. Analog signals: GPIO
6. Analog signals are sensitive to noise and should be routed away from high frequency signals.
7. High speed interfaces: **UART**, **SPI** and **SWD** pins.
8. High speed interfaces can be a source of radiated noise and can affect compliance with regulatory standards for radiated emissions. Follow the recommendations provided in sections 3.4.1 and 2.4.2 for schematic and layout design.
9. System functions: **RESET_N**, **I2C**, **GPIO** and other System input and output pins.
10. Accurate design is required to guarantee that the voltage level is well defined during module boot.
11. Other pins:
12. Accurate design is required to guarantee proper functionality.

3.2 Antenna interface

As the unit cannot be mounted arbitrary, the placement should be chosen with consideration so that it does not interfere with radio communication. The ANNA-B112 using the internal antenna cannot be mounted in a metal enclosure. No metal casing or plastics using metal flakes should be used. Avoid metallic based paint or lacquer as well. Using the ANNA-B112 with external antenna offers more freedom as the antenna can be mounted further away from the module.

-  According to FCC regulations, the transmission line from the module's antenna pin to the antenna or antenna connector on the host PCB is considered part of the approved antenna design. Therefore, module integrators must either follow exactly one of the antenna reference design used in the module's FCC type approval or certify their own designs.

3.2.1 ANNA-B112 Internal antenna design

-  If a metal enclosure is required, ANNA-B112 using the antenna pin and an external antenna has to be used.

It is recommended to place the ANNA-B112 module so that the internal antenna is in the corner of the host PCB. The next best option is to position the antenna along one side of the host PCB ground plane. It is beneficial to have a large ground plane on the host PCB and have a good grounding for the ANNA-B112 module. Detailed description of the antenna trace and requirements can be found in appendix B.

3.2.1.1 Board size considerations

For a large PCB, (such as a board where the length and width are larger than one wavelength (61.5 mm), the shape and size of the ground plane is not critical.

For smaller PCBs where the length and the width are below one wavelength (61.5 mm), the size and shape of the ground plane is an important factor. See examples in appendix B.4.

3.2.1.2 Antenna trace design

The two versions of the trace design for using the internal antenna are described in appendix B.

3.2.2 ANNA-B112 External antenna design

3.2.2.1 Antenna trace design

The certified trace design to a U.FL connector is described in appendix B.

3.2.3 General antenna design guidelines

Designers must take care of the antennas from all perspective at the beginning of the design phase when the physical dimensions of the application board are under analysis/decision as the RF compliance of the device integrating ANNA-B112 module with all the applicable required certification schemes heavily depends on the radiating performance of the antennas. The designer is encouraged to consider one of the u-blox suggested antenna part numbers and follow the layout requirements.

- External antennas such as linear monopole.
- External antennas basically do not imply physical restriction to the design of the PCB where the module is mounted.
- The radiation performance mainly depends on the antennas. It is required to select antennas with optimal radiating performance in the operating bands.
- RF cables should be carefully selected with minimum insertion losses. Additional insertion loss will be introduced by low quality or long cable. Large insertion loss reduces radiation performance.
- A high quality 50 Ω coaxial connector provides proper PCB-to-RF-cable transition.
- Integrated antennas such as patch-like antennas:
- Internal integrated antennas imply physical restriction to the PCB design:

Integrated antenna excites RF currents on its counterpoise, typically the PCB ground plane of the device that becomes part of the antenna. The ground plane size can be reduced down to the size of the module itself and still generate good radiated power. However, the antenna radiated power tends to fluctuate the smaller ground plane, especially below about 1.2 PCB wavelength. Care must be taken to find an optimum by measuring radiated power or range. See the examples provided in Appendix B.4.

The RF isolation between antennas in the system must be as high as possible and the correlation between the 3D radiation patterns of the two antennas has to be as low as possible. In general, an RF separation of at least a quarter wavelength between the two antennas is required to achieve a maximum isolation and low pattern correlation; increased separation should be considered if possible, to maximize the performance and fulfil the requirements in Table 13.

As numerical example, the physical restriction to the PCB design can be considered as shown below:

Frequency = 2.4 GHz \rightarrow Wavelength = 12.5 cm \rightarrow Quarter wavelength = 3.125 cm

- Radiation performance depends on the whole product and antenna system design, including product mechanical design and usage. Antennas should be selected with optimal radiating performance in the operating bands according to the mechanical specifications of the PCB and the whole product.

Table 13 summarizes the requirements for the antenna RF interface.

| Item | Requirements | Remarks |
|-----------------|--|---|
| Impedance | 50 Ω nominal characteristic impedance | The impedance of the antenna RF connection must match the 50 Ω impedance of the ANT pin. |
| Frequency Range | 2400 - 2500 MHz | Bluetooth low energy. |
| Return Loss | $S_{11} < -10$ dB (VSWR < 2:1) recommended $S_{11} < -6$ dB (VSWR < 3:1) acceptable | The Return loss or the S_{11} , as the VSWR, refers to the amount of reflected power, measuring how well the primary antenna RF connection matches the 50 Ω characteristic impedance of the ANT pin. The impedance of the antenna termination must match as much as possible the 50 Ω nominal impedance of the ANT pin over the operating frequency range thus, maximizing the amount of the power transferred to the antenna. |
| Efficiency | > -1.5 dB (> 70%) recommended > -3.0 dB (> 50%) acceptable | The radiation efficiency is the ratio of the radiated power to the power delivered to the antenna input; the efficiency is a measure of how well an antenna receives or transmits. |
| Maximum Gain | Refer to Section 5 | The maximum antenna gain must not exceed the value specified in type approval documentation to comply with the radiation exposure limits specified by regulatory agencies. |

Table 13: Summary of antenna interface requirements for ANNA-B112

In both the cases, while selecting external or internal antennas, the following recommendations should be observed:

- Select antennas that provide optimal return loss (or VSWR) figure over all the operating frequencies.
- Select antennas that provide optimal efficiency figure over all the operating frequencies.
- Select antennas that provide appropriate gain figure (that is, combined antenna directivity and efficiency figure) so that the electromagnetic field radiation intensity does not exceed the regulatory limits specified in some countries (for example, by FCC in the United States).

3.2.3.1 RF transmission line design

RF transmission lines, such as the ones from the antenna output up to the related antenna connector or up to the related internal antenna pad, must be designed so that the characteristic impedance is as close as possible to 50 Ω . Figure 26 shows the design options and the main parameters to be considered when implementing a transmission line on a PCB:

- Micro strip: track coupled to a single ground plane, separated by dielectric material.
- Coplanar micro strip: track coupled to the ground plane and side conductors, which is separated by dielectric material.
- Strip line: track sandwiched between two parallel ground planes, separated by dielectric material.

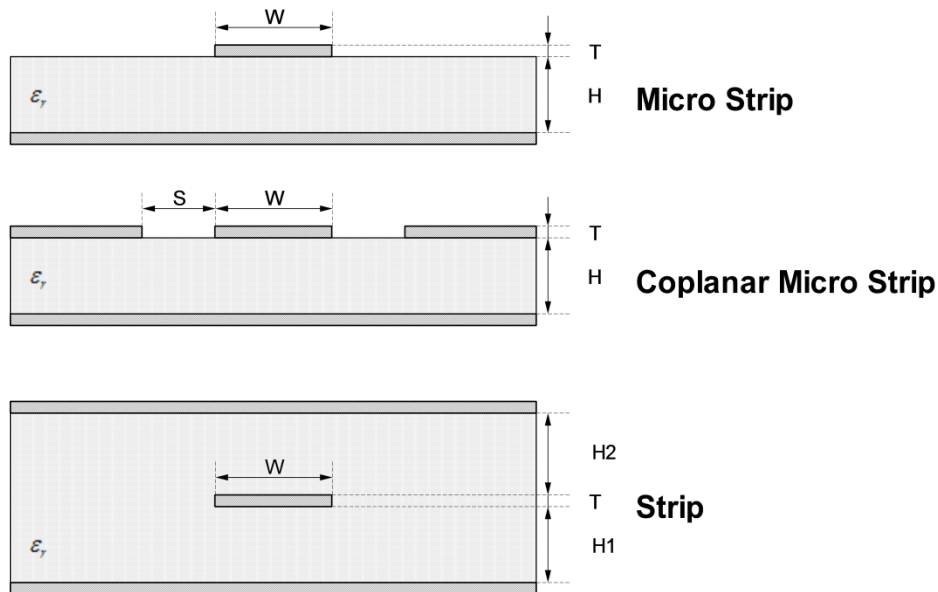

Figure 26: Transmission line trace design

To properly design a 50 Ω transmission line, the following points should be considered:

- The designer should provide enough clearance from surrounding traces and ground in the same layer; in general, a trace to ground clearance of at least two times the trace width should be considered. The transmission line should be ‘guarded’ by ground plane area on each side.
- The characteristic impedance can be calculated as first iteration using tools provided by the layout software. It is advisable to ask the PCB manufacturer to provide the final values that are usually calculated using dedicated software and available stack-ups from production. It could also be possible to request an impedance coupon on panel’s side to measure the real impedance of the traces.
- FR-4 dielectric material has high losses at high frequencies, but can be considered in RF designs provided that the RF trace length is minimized to reduce dielectric losses.
- If traces longer than few centimeters are needed, a coaxial cable and connector are recommended to reduce losses.
- Stack-up should allow for thick 50 Ω traces and at least 200 μm trace width is recommended to assure good impedance control over the PCB manufacturing process.
- FR-4 material exhibits poor thickness stability and thus less control of impedance over the trace length. Contact the PCB manufacturer for specific tolerance of controlled impedance traces.
- The transmission lines’ width and spacing to GND must be uniform and routed as smoothly as possible: route RF lines in 45° angle or in arcs.
- Add GND stitching vias around transmission lines.
- Ensure solid metal connection of the adjacent metal layer on the PCB stack-up to main ground layer, providing enough vias on the adjacent metal layer.
- Route RF transmission lines far from any noise source (such as switching supplies and digital lines) and any sensitive circuit to avoid crosstalk between RF traces and Hi-impedance or analog signals.
- Avoid stubs on the transmission lines; any component on the transmission line should be placed with the connected pad over the trace. Also avoid any unnecessary component on RF traces.

3.2.3.2 RF connector design

If an external antenna is required, the designer should consider using a proper RF connector. It is the responsibility of the designer to verify the compatibility between plugs and receptacles used in the design.

Table 14 suggests some RF connector plugs that can be used by the designers to connect RF coaxial cables based on the declaration of the respective manufacturers. The Hirose U.FL-R-SMT RF receptacles (or similar parts) require a suitable mated RF plug from the same connector series. Due to wide usage of this connector, several manufacturers offer compatible equivalents.

| Manufacturer | Series | Remarks |
|-------------------------------|---|-------------|
| Hirose | U.FL® Ultra Small Surface Mount Coaxial Connector | Recommended |
| I-PEX | MHF® Micro Coaxial Connector | |
| Tyco | UMCC® Ultra-Miniature Coax Connector | |
| Amphenol RF | AMC® Amphenol Micro Coaxial | |
| Lighthouse Technologies, Inc. | IPX ultra micro-miniature RF connector | |

Table 14: U.FL compatible plug connector

Typically, the RF plug is available as a cable assembly. Different types of cable assembly are available; the user should select the cable assembly best suited to the application. The key characteristics are:

- RF plug type: select U.FL or equivalent
- Nominal impedance: 50 Ω
- Cable thickness: Typically from 0.8 mm to 1.37 mm. Select thicker cables to minimize insertion loss.
- Cable length: Standard length is typically 100 mm or 200 mm; custom lengths may be available on request. Select shorter cables to minimize insertion loss.
- RF connector on the other side of the cable: for example another U.FL (for board-to-board connection) or SMA (for panel mounting)

Consider that SMT connectors are typically rated for a limited number of insertion cycles. In addition, the RF coaxial cable may be relatively fragile compared to other types of cables. To increase application ruggedness, connect U.FL connector to a more robust connector such as SMA fixed on panel.

 A de-facto standard for SMA connectors implies the usage of reverse polarity connectors (RP-SMA) on Wi-Fi and Bluetooth end products to increase the difficulty for the end user to replace the antenna with higher gain versions and exceed regulatory limits.

The following recommendations apply for proper layout of the connector:

- Strictly follow the connector manufacturer's recommended layout:
- SMA Pin-Through-Hole connectors require GND keep-out (that is, clearance, a void area) on all the layers around the central pin up to annular pads of the four GND posts.
- UFL surface mounted connectors require no conductive traces (that is, clearance, a void area) in the area below the connector between the GND land pads.
- If the connector's RF pad size is wider than the micro strip, remove the GND layer beneath the RF connector to minimize the stray capacitance thus keeping the RF line 50 Ω . For example, the active pad of the U.F.L connector must have a GND keep-out (that is, clearance, a void area) at least on the first inner layer to reduce parasitic capacitance to ground.

3.2.3.3 Integrated antenna design

If integrated antennas are used, the transmission line is terminated by the integrated antennas themselves. The following guidelines should be followed:

- The antenna design process should begin at the start of the whole product design process. Self-made PCBs and antenna assembly are useful in estimating overall efficiency and radiation path of the intended design.
- Use antennas designed by an antenna manufacturer providing the best possible return loss (or VSWR).

- Provide a ground plane large enough according to the related integrated antenna requirements. The ground plane of the application PCB may be reduced down to a minimum size that must be similar to one quarter of wavelength of the minimum frequency that has to be radiated, however overall antenna efficiency may benefit from larger ground planes. Proper placement of the antenna and its surroundings is also critical for antenna performance. Avoid placing the antenna close to conductive or RF-absorbing parts such as metal objects, ferrite sheets and so on as they may absorb part of the radiated power or shift the resonant frequency of the antenna or affect the antenna radiation pattern.
- It is highly recommended to strictly follow the detailed and specific guidelines provided by the antenna manufacturer regarding correct installation and deployment of the antenna system, including PCB layout and matching circuitry.
- Further to the custom PCB and product restrictions, antennas may require tuning/matching to comply with all the applicable required certification schemes. It is recommended to consult the antenna manufacturer for the design-in guidelines and plan the validation activities on the final prototypes like tuning/matching and performance measures (see Table 13).
- RF section may be affected by noise sources like hi-speed digital buses. Avoid placing the antenna close to buses such as DDR or consider taking specific countermeasures like metal shields or ferrite sheets to reduce the interference.

 Take care of interaction between co-located RF systems like LTE sidebands on 2.4 GHz band. Transmitted power may interact or disturb the performance of ANNA-B112 module.

3.3 Supply interfaces

3.3.1 Module supply design

Good connection of the module's VCC pin with DC supply source is required for correct RF performance. The guidelines are summarized below:

- The VCC connection must be as wide and short as possible.
- The VCC connection must be routed through a PCB area separated from sensitive analog signals and sensitive functional units. It is a good practice to interpose at least one layer of PCB ground between VCC track and other signal routing.

There is no strict requirement of adding bypass capacitance to the supply net close to the module. But depending on the layout of the supply net and other consumers on the same net, bypass capacitors might still be beneficial. Though the GND pins are internally connected, connect all the available pins to solid ground on the application board, as a good (low impedance) connection to an external ground can minimize power loss and improve RF and thermal performance.

3.4 Data communication interfaces

3.4.1 Asynchronous serial interface (UART) design

The layout of the UART bus should be done so that noise injection and cross talk are avoided.

It is recommended to use the hardware flow control with RTS/CTS to prevent temporary UART buffer overrun.

- If CTS is 1, then the Host/Host Controller is allowed to send.
- If CTS is 0, then the Host/Host Controller is not allowed to send.

3.4.2 Serial peripheral interface (SPI)

The layout of the SPI bus should be done so that noise injection and cross talk are avoided.

3.4.3 I2C interface

The layout of the I2C bus should be done so that noise injection and cross talk are avoided.

3.5 NFC interface

- ⚠ Ensure that the NFC pins are configured correctly. Connecting an NFC antenna to the pins configured as GPIO will damage the module.

The NFC antenna coil must be connected differentially between NFC1 and NFC2 pins of the device.

Two external capacitors should be used to tune the resonance of the antenna circuit to 13.56 MHz.

The required tuning capacitor value is given by the below equations: An antenna inductance of $L_{ant} = 2 \mu\text{H}$ will give tuning capacitors in the range of 130 pF on each pin. For good performance, match the total capacitance on NFC1 and NFC2.

The ANNA-B112 module have been tested with a 3x3 cm PCB trace antenna, so it is recommended to keep an antenna design close to these measurements. You can still use a smaller or larger antenna as long as it is tuned to resonate at 13.56 MHz. In order to comply with European regulatory demands, the NFC antenna must be placed in such a way that the space between the ANNA-B112 module and the remote NFC transmitter is always within 3 meters during transmission.

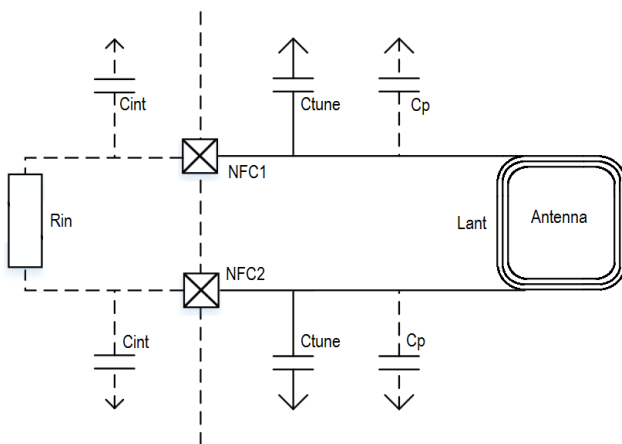

Figure 27: NFC antenna design

$$C'_{tune} = \frac{1}{(2\pi \times 13.56 \text{ MHz})^2 L_{ant}} \text{ where } C'_{tune} = \frac{1}{2} \times (C_p + C_{int} + C_{tune})$$

$$C_{tune} = \frac{2}{(2\pi \times 13.56 \text{ MHz})^2 L_{ant}} - C_p - C_{int}$$

3.5.1 Battery protection

If the antenna is exposed to a strong NFC field, current may flow in the opposite direction on the supply due to parasitic diodes and ESD structures.

If the battery used does not tolerate return current, a series diode must be placed between the battery and the device in order to protect the battery.

3.6 General High Speed layout guidelines

These general design guidelines are considered as best practices and are valid for any bus present in the ANNA-B112 module; the designer should prioritize the layout of higher speed busses. Low frequency signals are generally not critical for layout.

- ⚠ One exception is represented by High Impedance traces (such as signals driven by weak pull resistors) that may be affected by crosstalk. For those traces, a supplementary isolation of $4w$ from other busses is recommended.

3.6.1 General considerations for schematic design and PCB floor-planning

- Verify which signal bus requires termination and add series resistor terminations to the schematics.
- Carefully consider the placement of the module with respect to antenna position and host processor.
- Verify with PCB manufacturer allowable stack-ups and controlled impedance dimensioning.
- Verify that the power supply design and power sequence are compliant with ANNA-B112 module specification (refer to section 1.4).

3.6.2 Module placement

- Accessory parts like bypass capacitors should be placed as close as possible to the module to improve filtering capability, prioritizing the placement of the smallest size capacitor close to module pads.
- ⚠ Take care not to place components close to the antenna area. Designers should carefully follow the recommendations from the manufacturer when deciding the distance between the antenna and other parts of the system. Designers should also maximize the distance of the antenna to high-frequency busses like DDRs and other related components, or consider an optional metal shield to reduce interferences that could otherwise be picked up by the antenna and subsequently reduce module sensitivity.
- An optimized module placement allows for better RF performance. The design aspects to consider when deciding where the module is best placed are discussed in section 1.10.

3.6.3 Layout and manufacturing

- Avoid stubs on high-speed signals. Even through-hole vias may have an impact on signal quality.
- Verify the recommended maximum signal skew for differential pairs and length matching of busses.
- Minimize the routing length; longer traces will degrade signal performance. Ensure that maximum allowable length for high-speed busses is not exceeded.
- Ensure that you track your impedance matched traces. Consult with your PCB manufacturer early in the project for proper stack-up definition.
- RF and digital sections should be clearly separated on the board.
- Ground splitting is not allowed below the module.
- Minimize bus length to reduce potential EMI issues from digital busses.
- All traces (including low speed or DC traces) must couple with a reference plane (GND or power); Hi-speed busses should be referenced to the ground plane. In this case, if the designer needs to change the ground reference, an adequate number of GND vias must be added in the area of transition to provide a low impedance path between the two GND layers for the return current.
- Hi-Speed busses are not allowed to change reference plane. If a reference plane change is unavoidable, some capacitors should be added in the area to provide a low impedance return path through the different reference planes.
- Trace routing should keep a distance greater than $3w$ from the ground plane routing edge.

- Power planes should keep a distance from the PCB edge sufficient to route a ground ring around the PCB, the ground ring must then be connected to other layers through vias.

3.7 Module footprint and paste mask

The mechanical outline of the ANNA-B112 series module can be found in the ANNA-B112 series data sheet [2]. The Proposed land pattern layout reflects the pads' layout of the module.

The Non Solder Mask Defined (NSMD) pad type is recommended over the Solder Mask Defined (SMD), which implements the solder mask opening 50 µm larger per side than the corresponding copper pad.

The suggested paste mask layout for the ANNA-B1 should follow the copper mask layout, as described in ANNA-B1 series data sheet [2].

-  These are recommendations only and not specifications. The exact mask geometries, distances, and stencil thicknesses must be adapted to the specific production processes of the customer.

3.8 Thermal guidelines

ANNA-B112 has been successfully tested in -40 °C to +85 °C. The ANNA-B112 module is a low power device and will generate only a small amount of heat during operation. A good grounding should still be observed for temperature relief during high ambient temperature.

3.9 ESD guidelines

The immunity of devices integrating ANNA-B112 module to Electro-Static Discharge (ESD) is part of the Electro-Magnetic Compatibility (EMC) conformity, which is required for products bearing the CE marking, compliant with the R&TTE Directive (99/5/EC), the EMC Directive (89/336/EEC) and the Low Voltage Directive (73/23/EEC) issued by the Commission of the European Community.

Compliance with these directives implies conformity to the following European Norms for device ESD immunity: ESD testing standard *CENELEC EN 61000-4-2* and the radio equipment standards *ETSI EN 301 489-1*, *ETSI EN 301 489-7*, *ETSI EN 301 489-24*, the requirements of which are summarized in Table 15.

The ESD immunity test is performed at the enclosure port, defined by *ETSI EN 301 489-1* as the physical boundary through which the electromagnetic field radiates. If the device implements an integral antenna, the enclosure port is seen as all insulating and conductive surfaces housing the device. If the device implements a removable antenna, the antenna port can be separated from the enclosure port. The antenna port includes the antenna element and its interconnecting cable surfaces.

The applicability of ESD immunity test to the whole device depends on the device classification as defined by *ETSI EN 301 489-1*. Applicability of ESD immunity test to the related device ports or the related interconnecting cables to auxiliary equipment, depends on device accessible interfaces and manufacturer requirements, as defined by *ETSI EN 301 489-1*.

Contact discharges are performed at conductive surfaces, while air discharges are performed at insulating surfaces. Indirect contact discharges are performed on the measurement setup horizontal and vertical coupling planes as defined in *CENELEC EN 61000-4-2*.

-  For the definition of integral antenna, removable antenna, antenna port, device classification refer to the *ETSI EN 301 489-1*. For the contact and air discharges definitions refer to *CENELEC EN 61000-4-2*.

| Application | Category | Immunity Level |
|---|----------------------------|----------------|
| All exposed surfaces of the radio equipment and ancillary equipment in a representative configuration | Indirect Contact Discharge | ±8 kV |

Table 15: Electro-Magnetic Compatibility ESD immunity requirements as defined by CENELEC EN 61000-4-2, ETSI EN 301 489-1, ETSI EN 301 489-7, ETSI EN 301 489-24

ANNA-B112 is manufactured with consideration to specific standards that minimize the occurrence of ESD events. The highly automated process complies with IEC61340-5-1 (STM5.2-1999 Class M1 devices) standard. Designers should implement proper measures to protect from ESD events and safeguard any pin that may be exposed to the end user.

Compliance with standard protection level specified in EN61000-4-2 can be achieved by including ESD protections in parallel to the line, close to areas accessible by the end user.

4 Handling and soldering

No natural rubbers, hygroscopic materials or materials containing asbestos are employed.

4.1 Packaging, shipping, storage, and moisture preconditioning

For information pertaining to reels, tapes or trays, moisture sensitivity levels (MSL), shipment and storage, as well as drying for preconditioning refer to ANNA-B112 data sheet [2] and u-blox package information guide [1].

4.2 Handling

ANNA-B112 modules are Electro-Static Discharge (ESD) sensitive devices and require special precautions during handling. Particular care must be exercised when handling patch antennas, due to the risk of electrostatic charges. In addition to standard ESD safety practices, the following measures should be taken into account whenever handling the receiver:

- Unless there is a galvanic coupling between the local GND (workbench ground for example) and the PCB GND, then the first point of contact when handling the PCB must always be between the local GND and PCB GND.
- Before mounting an antenna patch, connect ground of the device
- When handling the RF pin, do not come into contact with any charged capacitors and be careful when contacting materials that can develop charges; for example, patch antenna (~10 pF), coaxial cable (~50-80 pF/m), soldering iron, and so on.
- To prevent electrostatic discharge through the RF input, do not touch any exposed antenna area. If there is any risk that an exposed antenna area is touched in non-ESD protected work area, implement proper ESD protection measures in the design.
- When soldering RF connectors and patch antennas to the RF pin of the receiver, make sure to use an ESD-safe soldering iron (tip).

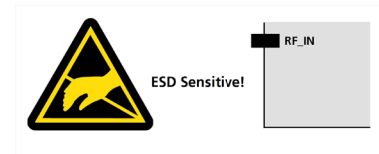

4.3 Soldering

4.3.1 Reflow soldering process

ANNA-B112 is a surface-mount module supplied on a FR4-type PCB with gold plated connection pads. It is manufactured in a lead-free process with a lead-free soldering paste. The bow and twist of the PCB is maximum 0.75% according to IPC-A-610E. The thickness of solder resist between the host PCB top side and the bottom side of ANNA-B112 must be considered for the soldering process.

The module is compatible with industrial reflow profile for RoHS solders. Use of "No Clean" soldering paste is strongly recommended.

The reflow profile used is dependent on the thermal mass of the entire populated PCB, heat transfer efficiency of the oven and particular type of solder paste used. The optimal soldering profile used has to be trimmed for each case depending on the specific process and PCB layout.

| Process parameter | | Unit | Value |
|-------------------|-----------------------------------|------|-------|
| Pre-heat | Ramp up rate to $T_{S\text{MIN}}$ | K/s | 3 |
| | $T_{S\text{MIN}}$ | °C | 150 |
| | $T_{S\text{MAX}}$ | °C | 200 |
| | t_s (from 25 °C) | s | 110 |
| | t_s (Pre-heat) | s | 60 |
| Peak | T_L | °C | 217 |
| | t_L (time above T_L) | s | 60 |
| | T_P (absolute max) | °C | 245 |
| | t_P (time above $T_P - 5$ °C) | s | 10 |
| Cooling | Ramp-down from T_L | K/s | 6 |
| General | $T_{\text{to peak}}$ | s | 300 |
| | Allowed reflow soldering cycles | - | 2 |

Table 16: Recommended reflow profiles

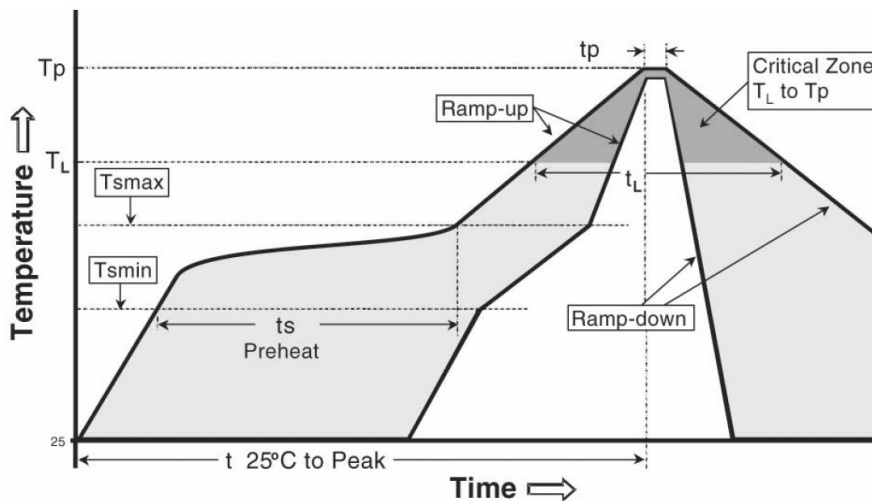

Figure 28: Reflow profile

- Lower value of T_P and slower ramp down rate (2 – 3 °C/sec) is preferred.
- After reflow soldering, optical inspection of the module is recommended to verify proper alignment.
- Target values in Table 16 should be taken as general guidelines for a Pb-free process. Refer to JEDEC J-STD-020C [6] standard for further information.

4.3.2 Cleaning

Cleaning the module is not recommended. Residues underneath the module cannot be easily removed with a washing process.

- Cleaning with water will lead to capillary effects where water is absorbed in the gap between the baseboard and the module. The combination of residues of soldering flux and encapsulated water leads to short circuits or resistor-like interconnections between neighboring pads.
- Cleaning with alcohol or other organic solvents can result in soldering flux residues flooding into areas that are not accessible for post-wash inspections.
- Ultrasonic cleaning will permanently damage the module, in particular the crystal oscillators.

For best results use a "no clean" soldering paste and eliminate the cleaning step after the soldering process.

4.3.3 Potting

If potting is required for the ANNA-B112 module, it is recommended to use a material with similar parameters as used in the module. The important parameters are described in Table 17.

The thickness of the potting should also be considered to avoid warpage of the PCB.

| Parameter | Unit | Value |
|------------------|------|-------|
| Shrinkage | % | 0.17 |
| Modulus (25 °C) | MPa | 20000 |
| Modulus (260 °C) | MPa | 500 |

Table 17: Parameters potting

If the antenna and/or antenna trace is covered by the potting, it will affect the RF characteristics of the module. This might also affect the certification of the module and the antenna will most likely be classified as a new antenna requiring recertification.

 No hardware troubleshooting will be done by u-blox support on the potted modules.

4.3.4 Other remarks

- Boards with combined through-hole technology (THT) components and surface-mount technology (SMT) devices may require wave soldering to solder the THT components. Only a single wave soldering process is allowed for boards populated with the module. *Miniature Wave Selective Solder* process is preferred over traditional wave soldering process.
- Hand soldering is not recommended.
- Rework is not recommended.
- Grounding metal covers: attempts to improve grounding by soldering ground cables, wick or other forms of metal strips directly onto the EMI covers is done at the customer's own risk and will void module's warranty. The numerous ground pins are adequate to provide optimal immunity to interferences.
- The module contains components that are sensitive to Ultrasonic Waves. Use of any ultrasonic processes such as cleaning, welding etc., may damage the module. Use of ultrasonic processes on an end product integrating this module will void the warranty.

5 Qualifications and approvals

For regulatory information, see the ANNA-B1 series Datasheet [2].

6 Product testing

6.1 u-blox in-series production test

u-blox focuses on high quality for its products. All units produced are fully tested automatically in production line. Stringent quality control process has been implemented in the production line. Defective units are analyzed in detail to improve the production quality.

This is achieved with automatic test equipment (ATE) in production line, which logs all production and measurement data. A detailed test report for each unit can be generated from the system. Figure 2929 illustrates typical automatic test equipment (ATE) in a production line.

The following tests are performed as part of the production tests:

- Digital self-test (software download, MAC address programming)
- Measurement of currents
- Functional tests
- Digital I/O tests
- Measurement of RF characteristics in all supported bands (such as receiver sensitivity, transmitter power levels and so on.)



Figure 29: Automatic test equipment for module test

6.2 OEM manufacturer production test

As the testing is already done by u-blox, an OEM manufacturer does not need to repeat software tests or measurement of the module's RF performance or tests over analog and digital interfaces in their production test.

However, an OEM manufacturer should focus on:

- Module assembly on the device; it should be verified that:
- Soldering and handling process did not damage the module components
- All module pins are well soldered on device board
- There are no short circuits between pins
- Component assembly on the device; it should be verified that:
- Communication with host controller can be established
- The interfaces between the module and device are working
- Overall RF performance test of the device including antenna

Dedicated tests can be implemented to check the device. For example, the measurement of module current consumption when set in a specified state can detect a short circuit if compared with a "Golden Device" result.

The standard operational module firmware and test software on the host can be used to perform functional tests (communication with the host controller, check interfaces) and to perform basic RF performance tests.

6.2.1 "Go/No go" tests for integrated devices

A "Go/No go" test compares the signal quality with a "Golden Device" in a location with known signal quality. This test can be performed after establishing a connection with an external device.

A very simple test can be performed by just scanning for a known Bluetooth low energy device and checking the signal level (Received Signal Strength Indicator (RSSI)).

 These kinds of test may be useful as a "go/no go" test but not for RF performance measurements.

This test is suitable to check the functionality of the communication with the host controller and the power supply. It is also a means to verify if components are well soldered.

A basic RF functional test of the device including the antenna can be performed with standard Bluetooth low energy devices as remote stations. The device containing the ANNA-B112 module and the antennas should be arranged in a fixed position inside an RF shield box to prevent interferences from other possible radio devices to get stable test results.

Appendix

A Glossary

| Abbreviation | Definition |
|--------------|---|
| ADC | Analog to Digital Converter |
| ATE | Automatic Test Equipment |
| BLE | Bluetooth Low Energy |
| CLI | Command Line Interface |
| CTS | Clear To Send |
| DDR | Dual-Data Rate |
| EMC | Electro-Magnetic Compatibility |
| EMI | Electro Magnetic Interference |
| ESD | Electro Static Discharge |
| EVK | Evaluation Kit |
| aFCC | Federal Communications Commission |
| GATT | Generic ATtribute profile |
| GND | Ground |
| GPIO | General Purpose Input/Output |
| IC | Industry Canada |
| I2C | Inter-Integrated Circuit |
| JSON | JavaScript Object Notation |
| LDO | Low Drop Out |
| LED | Light-Emitting Diode |
| MAC | Media Access Control |
| MSL | Moisture Sensitivity Level |
| NSMD | Non Solder Mask Defined |
| PCB | Printed Circuit Board |
| RF | Radio Frequency |
| RoHS | Restriction of Hazardous Substances |
| RSSI | Received Signal Strength Indicator |
| RTOS | Real Time Operating System |
| RTS | Request to Send |
| RXD | Receive Data |
| SCL | Signal Clock |
| SDL | Specification and Description Language |
| SMA | SubMiniature version A |
| SMD | Solder Mask Defined |
| SMPS | Switching Mode Power Supply |
| SMT | Surface-Mount Technology |
| SPI | Serial Peripheral Interface |
| SWD | Serial Wire Debug |
| THT | Through-Hole Technology |
| TXD | Transmit Data |
| UART | Universal Asynchronous Receiver/Transmitter |
| VCC | IC power-supply pin |

Table 18: Explanation of the abbreviations used

B Antenna reference designs

Designers can take full advantage of ANNA-B112's Single-Modular Transmitter certification approval by integrating the u-blox reference design into their products. This approach requires compliance with the following rules:

- Only listed antennas can be used. Refer to ANNA-B112 Data sheet [2] for the listed antennas.
- Schematics and parts used in the design must be identical to u-blox. RF components may show different behavior at the frequencies of interest due to different construction and parasitic; use u-blox's validated parts for antenna matching.
- PCB layout must be identical to the one provided by u-blox. Implement one of the reference designs included in this section or contact u-blox.
- The designer must use the stack-up provided by u-blox. RF traces on the carrier PCB are part of the certified design.

Three different reference designs are available as listed below:

- Using the internal antenna with the module in the corner of the PCB
- Using the internal antenna with the module along the edge of the PCB
- Using an external antenna by a short trace to a U.FL connector

B.1 Internal antenna reference design with module at PCB corner

When using the ANNA-B112 together with this antenna reference design, the circuit trace layout must be made in strict compliance with the instructions below.

This section describes where the critical copper traces are positioned on the reference design.

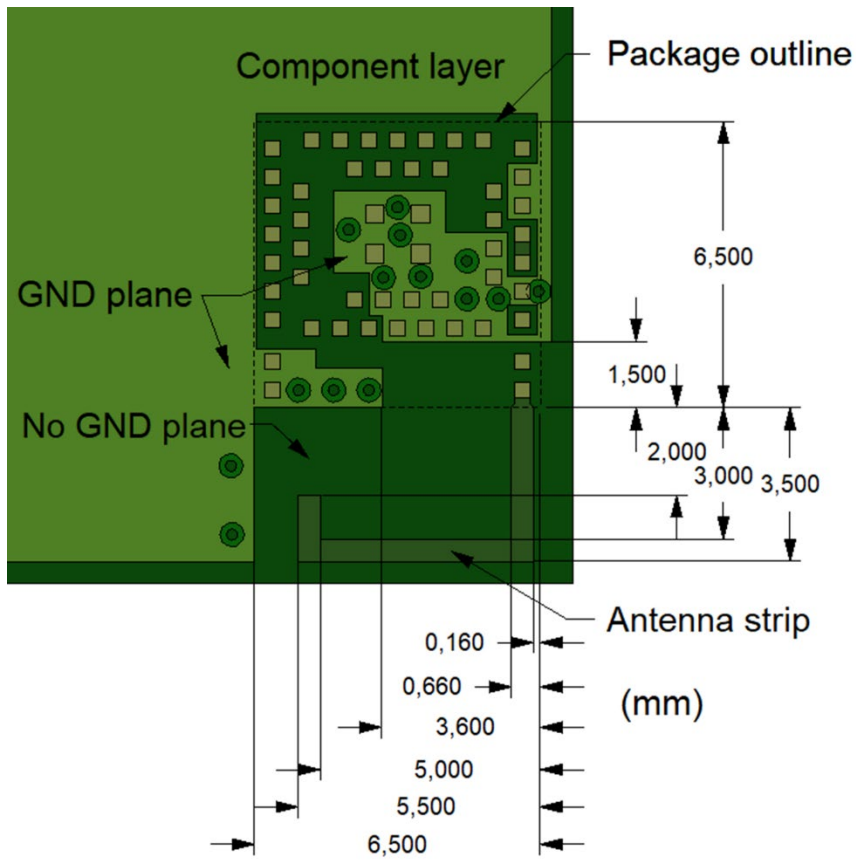

Figure 30: Reference design for internal antenna, corner version, top layer. Traces and vias for other signals not present.

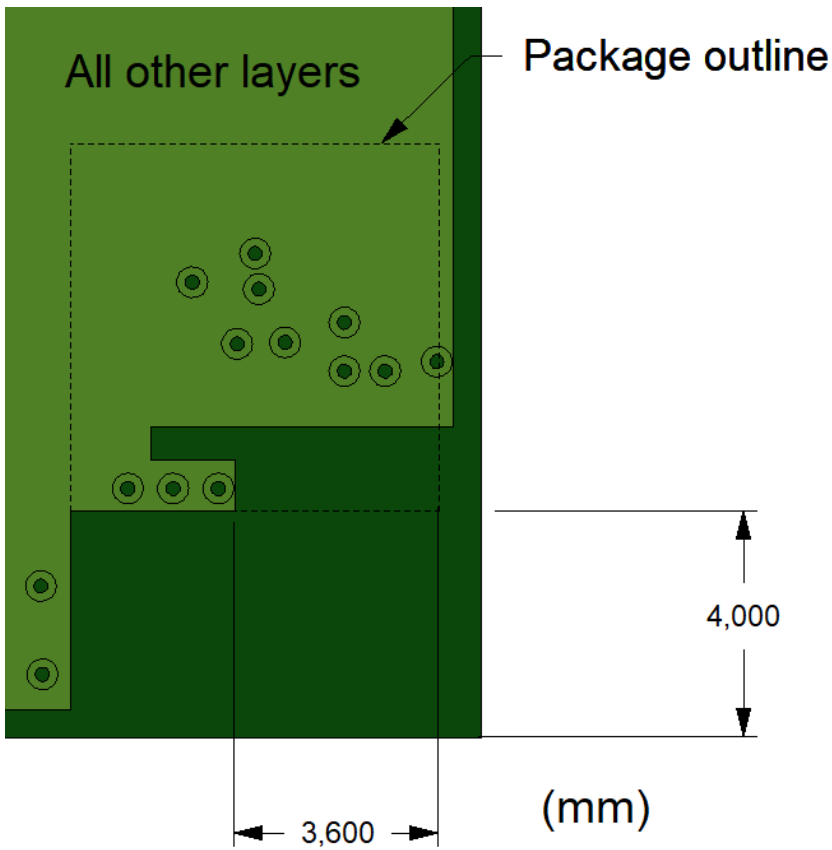

Figure 31: Reference design for internal antenna, corner version, other layer. Traces and vias for other signals not present

B.2 Internal antenna reference design with module along PCB edge

When using the ANNA-B112 together with this antenna reference design, the circuit trace layout must be made in strict compliance with the instructions below.

This section describes where the critical copper traces are positioned on the reference design.

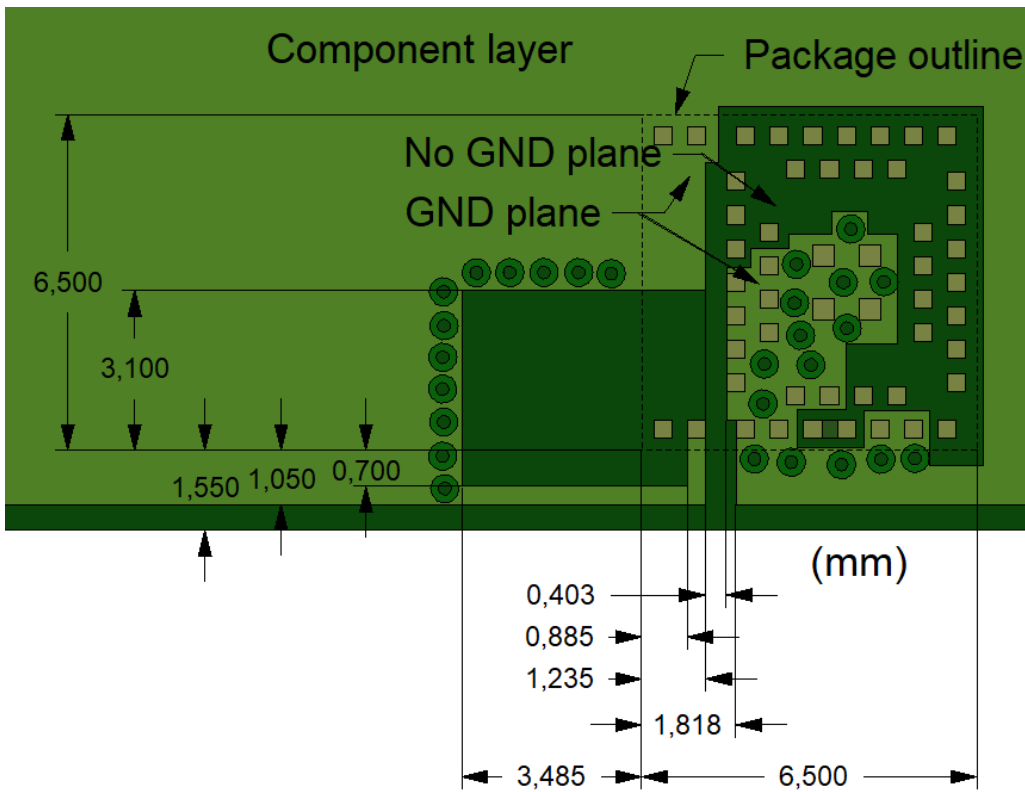

Figure 32: Reference design for internal antenna, edge version, top layer. Traces and vias for other signals are not present

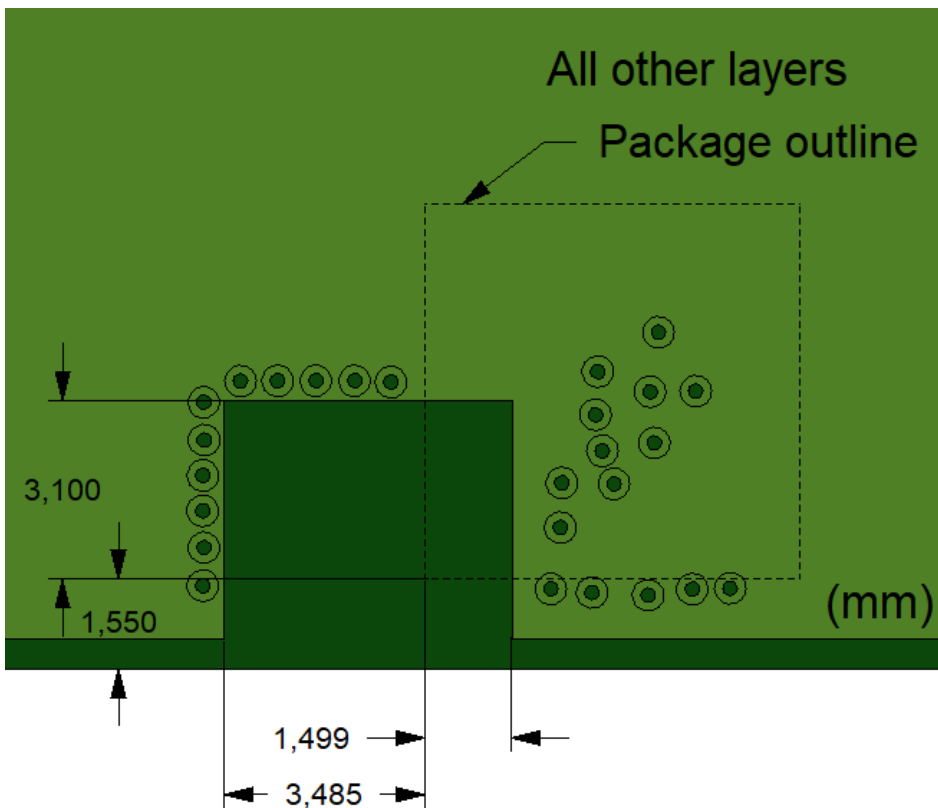

Figure 33: Reference design for internal antenna, edge version, other layers. Traces and vias for other signals not present

B.3 Reference design for external antennas (U.FL connector)

When using ANNA-B112 together with this antenna reference design, the circuit trace layout must be made in strict compliance with the instructions below.

All the components placed on each RF trace must be kept as indicated in the reference design. The reference design uses a micro coaxial connector that is connected to the external antenna via a 50 Ω pigtail.

This section describes where the critical components and copper traces are positioned on the reference design.

| Part | Manufacturer | Description |
|------------------|--------------|--|
| U.FL-R-SMT-1(10) | Hirose | Coaxial Connector, 0 – 6 GHz, for external antenna |

Table 19: U.FL connector used in the ANNA-B112 reference design

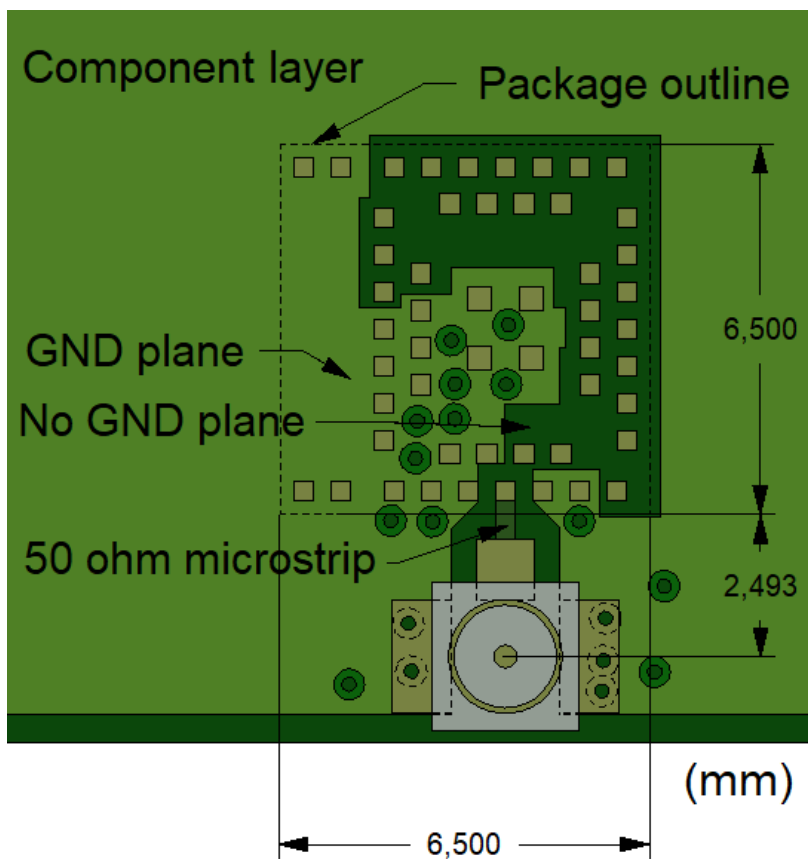

Figure 34: Reference design for external antenna, top layer. Traces and vias for other signals are not present

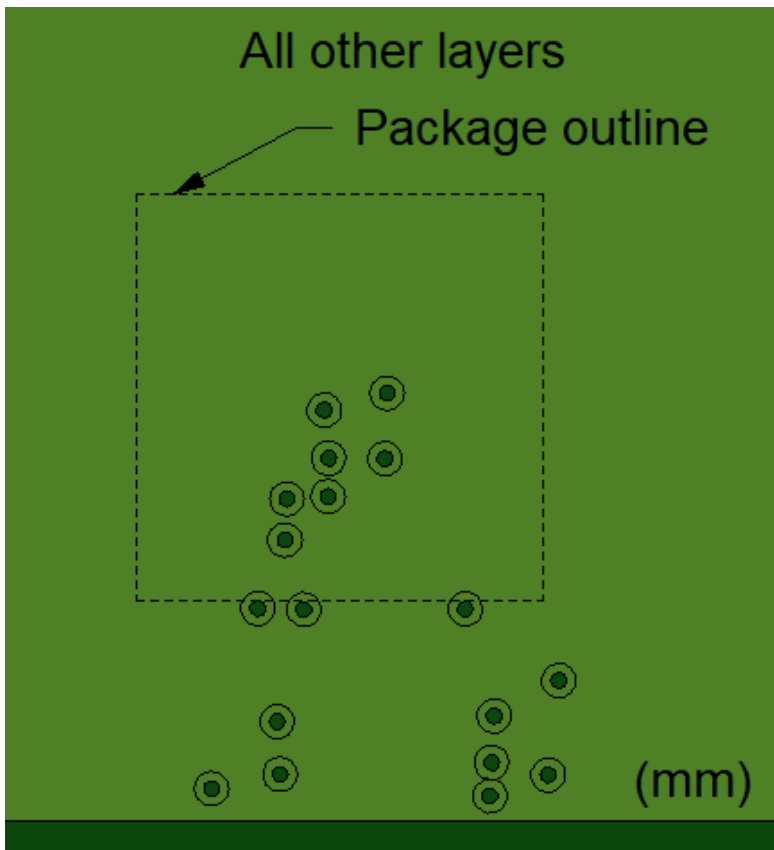

Figure 35: Reference design for external antenna, other layers. Traces and vias for other signals are not present.

The 50 Ω coplanar micro-strip dimensions used in the reference design are stated in Figure 36 and Table 20. The GND plane beneath the RF trace must be intact.

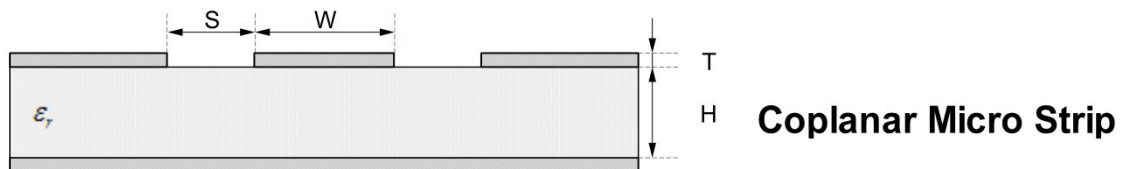

Figure 36: Coplanar micro-strip dimension specification

| Item | Value |
|--------------|---|
| T | Soldermask: 20 +/- 10 μm Copper film and plating/surface coating: 35 +/- 15 μm |
| ϵ_r | 3.77 +/- 0.5 |

Table 20: Coplanar micro-strip specification

B.4 Examples of application ground plane miniaturizations

The following boards are used as examples to show what's possible when reducing board size. Since the radiated power fluctuates when using a small ground plane, care must be taken to ensure a sufficient range and radiated power for every application ground plane size. Range measurement in a field, line of sight recommended, or measure the radiated power in an RF diagnostic chamber are two ways to confirm antenna efficiency.

B.4.1 Example application 1

The C8_1 board with ANNA-B1 module in the corner, mounted to the left as shown in Figure 3737 is the first example that shows what can be achieved by shrinking the board size. The below graph visualizes the correlation between the total radiated power, TRP, and the ground plane size. The C8_1 board represents the peak power of -5.67 dBm. It has a wavelength part of 0.75 in x-axis and 0.14 in Y-axis corresponding to 46 mm and 8 mm respectively. Additionally, the TRP patterns of the C8_1 board illustrates a nice round even shape as shown in Figure 3939.

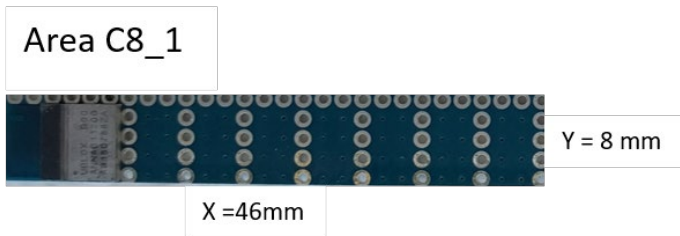

Figure 37: An example of ground plane miniaturization and still having a good range, about 250 m

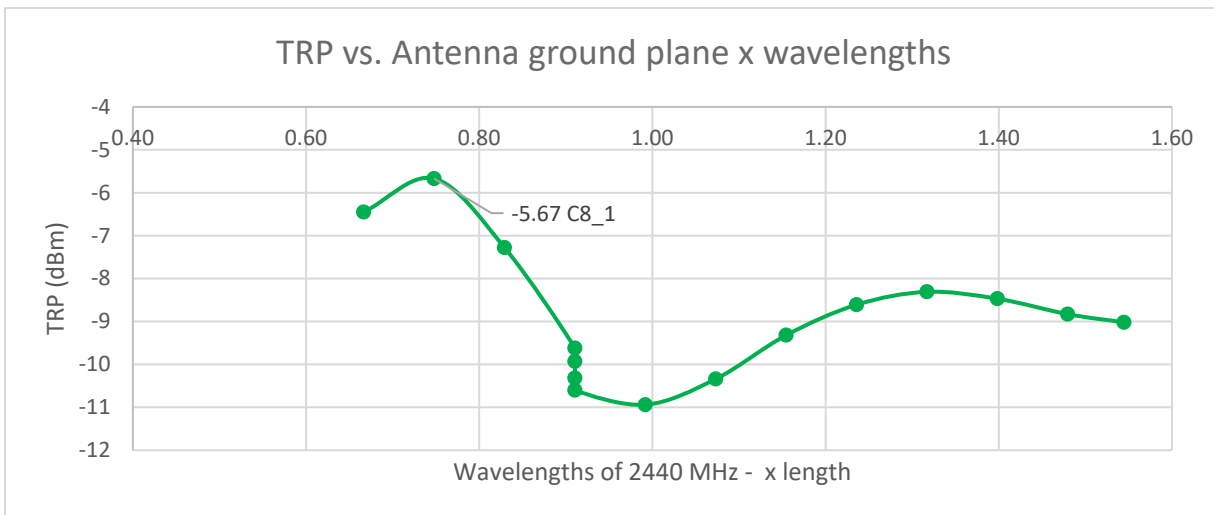

Figure 38: The C8_1 board, TRP peak, can be found in the TRP graph where different board sizes in wave lengths are plotted

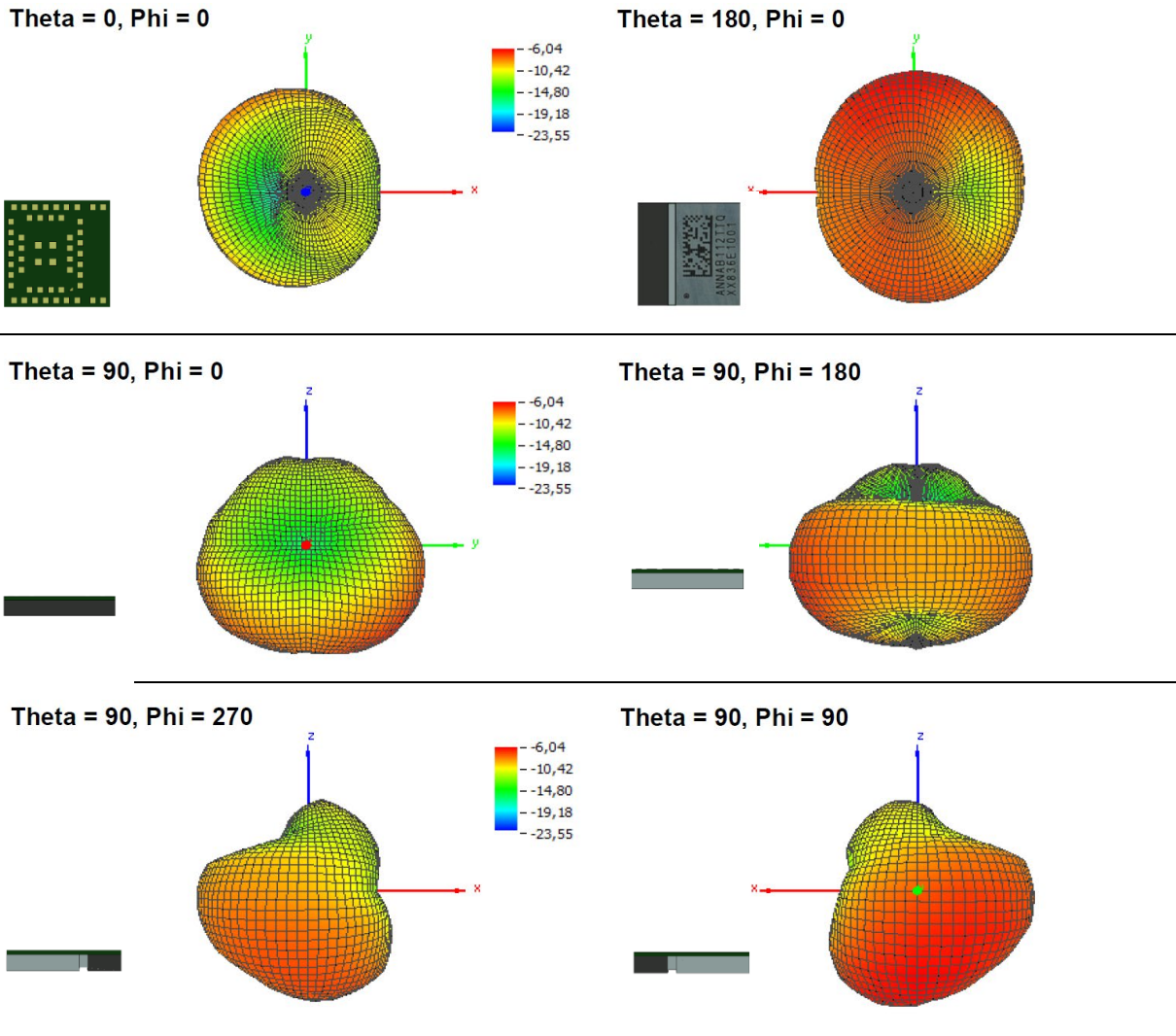

Figure 39: The C8_1 graphs show the total radiation power patterns. Integrating the graph the TRP is achieved, -5.67 dBm. A spherical shape is ideal

B.4.2 Example application 2

The tiny device in Figure 4040 is an example of building with both range and miniaturization in mind. In this case they go hand in hand. It gives a TRP of -8.4 dBm corresponding to a range of about 100 m, the size of the module itself.

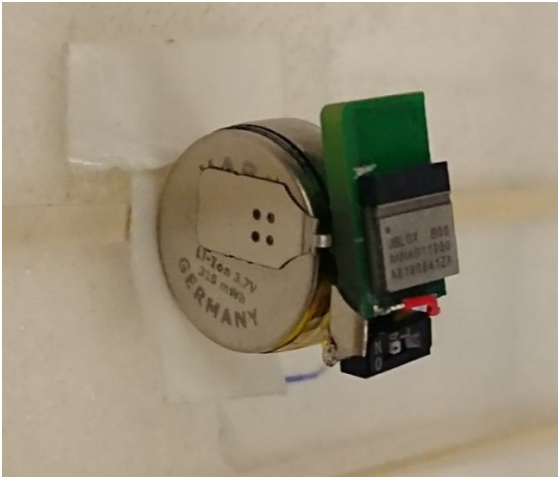
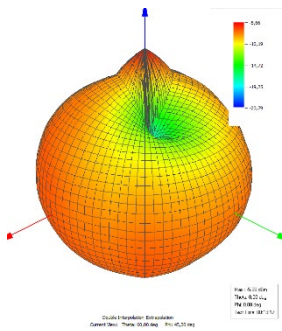

Figure 40: A tiny ANNA-B1 application including coin cell battery with the range of about 100 m, size 7.5 x 12 mm

Theta = 60, Phi = 45



Theta = 1.4, Phi = 189.5

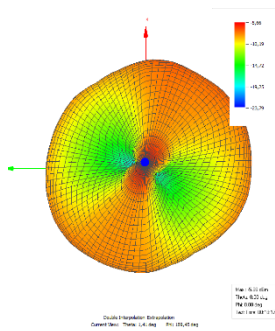



Figure 41: The tiny ANNA-B1 graphs show the total radiation power patterns. Integrating the graph the TRP is achieved, -8.4 dBm. A spherical shape is ideal

Related documents

- [1] u-blox package information guide, [UBX-14001652](#)
- [2] ANNA-B112 data sheet, [UBX-18011707](#)
- [3] u-connectXpress software user guide, [UBX-16024251](#)
- [4] u-connect AT commands manual, [UBX-14044127](#)
- [5] Adding and configuring Mbed targets, https://docs.mbed.com/docs/mbedmicro-api/en/latest/api/md_docs_mbed_targets.html
- [6] JEDEC J-STD-020C - Moisture/Reflow Sensitivity Classification for Non Hermetic Solid State Surface Mount Devices
- [7] IEC EN 61000-4-2 - Electromagnetic compatibility (EMC), Part 4-2: Testing and measurement techniques – Electrostatic discharge immunity test
- [8] ETSI EN 301 489-1 - Electromagnetic compatibility and Radio spectrum Matters (ERM); ElectroMagnetic Compatibility (EMC) standard for radio equipment and services; Part 1: Common technical requirements
- [9] IEC61340-5-1 - Protection of electronic devices from electrostatic phenomena – General requirements
- [10] ETSI EN 60950-1:2006 - Information technology equipment – Safety – Part 1: General requirements
- [11] FCC Regulatory Information, Title 47 – Telecommunication
- [12] JESD51 – Overview of methodology for thermal testing of single semiconductor devices
- [13] Nordic Semiconductor Infocenter, <https://infocenter.nordicsemi.com/index.jsp>
- [14] Using the public IEEE address from UICR, [UBX-19055303](#)
- [15] RC oscillator configuration for nRF5 open CPU modules, [UBX-20009242](#)
- [16] Zephyr Project, <https://www.zephyrproject.org/>
- [17] u-blox shortrange open CPU github repository, <https://github.com/u-blox/u-blox-sho-OpenCPU>
- [18] Zephyr Project Documentation, <https://docs.zephyrproject.org>
- [19] <https://devzone.nordicsemi.com/nordic/short-range-guides/b/getting-started/posts/adjustment-of-ram-and-flash-memory>
- [20] nRF Connect SDK page at Nordic Semiconductor, <https://www.nordicsemi.com/Software-and-tools/Software/nRF-Connect-SDK>
- [21] Bluetooth Mesh with u-connect software, [UBX-19025268](#)

 For product change notifications and regular updates of u-blox documentation, register on our website, www.u-blox.com.

Revision history

| Revision | Date | Name | Comments |
|----------|-------------|------------------|--|
| R01 | 27-Mar-2018 | fbro, apet | Initial release. |
| R02 | 16-May-2018 | fbro, kgom | Changed the product status to Engineering Sample. Updated main features summary (Table 1). Include antenna trace design information (Appendix B). Updated target values in recommended reflow profiles (Table 16) and information about cleaning the module (section 4.3.2). |
| R03 | 6-Nov-2018 | fbro | Changed the product status to Initial Production. Updated trace design information (Appendix B). Added information about low power clock (section 1.6) and potting (section 4.3.3). |
| R04 | 20-Dec-2018 | lalb | Updated section 1.1 with information that the certification for Taiwan has been completed. |
| R05 | 2-Apr-2019 | hekf, fbro | <p>Added new software version 2.0.0, new ordering codes/type numbers in the table on page 2. Updated section 1.1 with information that the certification for South Korea has been completed. Updated Table 1. Added more information about the selection of low power clock source (section 1.6.5). Clarified the ground plane and signals (no design change), concerning all figures in Antenna reference designs, appendix B.</p> <p>Replaced "u-blox connectivity software" with "u-connectXpress software" in all instances. Replaced all references to the "ANNA-B112 GettingStarted" guide with the new document "Using u-connectXpress user guide". Updated the document name of the "u-blox Short Range AT commands manual" to the new name "u-connect AT commands manual" (UBX-14044127).</p> |
| R06 | 27-Sep-2019 | fbro, mape, hekf | <p>Added more information about potting requirements. Rearranged Antenna interface (section 3.2) for better clarity. Removed minimum GND length of 3.5 mm from antenna trace design in Appendix B.</p> <p>Removed the deprecated tool nRFGo Studio, and replaced with a description of the nRF Connect Programmer tool, which is now promoted by Nordic Semiconductor.</p> <p>Changed recommendation for running without external Xtal to connect XL_1+XL_2 to ground.</p> <p>Added information about ground plane and example applications in section 3.2.1.1 and B.4.</p> |
| R07 | 30-Mar-2020 | fbro, mape, ctur | Changed product status to Mass Production. Updated antenna pin recommendations in Table 12 when using an external antenna (connect unused pins to GND instead of NC). |
| R08 | 6-Nov-2020 | mape | Added ANNA-B112-70B variant. |
| R09 | 09-Feb-2021 | mape | <p>Added information about how to use build configurations for nRF5 SDK for open CPU. Included information about Zephyr configurations in section 2.2.2.</p> <p>Added information about mesh SW.</p> |

Contact

For complete contact information, visit us at www.u-blox.com.

u-blox Offices

North, Central and South America

u-blox America, Inc.

Phone: +1 703 483 3180

E-mail: info_us@u-blox.com

Regional Office West Coast:

Phone: +1 408 573 3640

E-mail: info_us@u-blox.com

Technical Support:

Phone: +1 703 483 3185

E-mail: support@u-blox.com

Headquarters

Europe, Middle East, Africa

u-blox AG

Phone: +41 44 722 74 44

E-mail: info@u-blox.com

Support: support@u-blox.com

Asia, Australia, Pacific

u-blox Singapore Pte. Ltd.

Phone: +65 6734 3811

E-mail: info_ap@u-blox.com

Support: support_ap@u-blox.com

Regional Office Australia:

Phone: +61 3 9566 7255

E-mail: info_au@u-blox.com

Support: support_au@u-blox.com

Regional Office China (Beijing):

Phone: +86 10 68 133 545

E-mail: info_cn@u-blox.com

Support: support_cn@u-blox.com

Regional Office China (Chongqing):

Phone: +86 23 6815 1588

E-mail: info_cn@u-blox.com

Support: support_cn@u-blox.com

Regional Office China (Shanghai):

Phone: +86 21 6090 4832

E-mail: info_cn@u-blox.com

Support: support_cn@u-blox.com

Regional Office China (Shenzhen):

Phone: +86 755 8627 1083

E-mail: info_cn@u-blox.com

Support: support_cn@u-blox.com

Regional Office India:

Phone: +91 80 405 092 00

E-mail: info_in@u-blox.com

Support: support_in@u-blox.com

Regional Office Japan (Osaka):

Phone: +81 6 6941 3660

E-mail: info_jp@u-blox.com

Support: support_jp@u-blox.com

Regional Office Japan (Tokyo):

Phone: +81 3 5775 3850

E-mail: info_jp@u-blox.com

Support: support_jp@u-blox.com

Regional Office Korea:

Phone: +82 2 542 0861

E-mail: info_kr@u-blox.com

Support: support_kr@u-blox.com

Regional Office Taiwan:

Phone: +886 2 2657 1090

E-mail: info_tw@u-blox.com

Support: support_tw@u-blox.com