

LT8551 High Power Boost Converter Based on the Phase Expander

DESCRIPTION

Demonstration circuit 2896A-B demonstrates a high power boost converter and features the [LT[®]8551](#) the phase expander with internal gate drivers. The DC2896A-B employs [LTC3769](#), a single-phase boost controller as primary controller and LT8551 as the phase expander which added four more power phases. The increased number of power sections connected to the LT8551, results in greater higher level output power without a corresponding increase in the difficulty of the design or a sacrifice of primary controller LTC3769 features.

The input voltage range of DC2896A-B is from 10V to 46V and the output is 48V. The maximum input current is 12A per power section, so the maximum input current of DC2896A-B is 60A. It's reflected to 30A of output current and output power of 1,440W at an input voltage of 24V. Correspondingly output current will drop to 14.5A and output power will to 720W at a 12V input voltage, to keep the input current at the same level of 60A. Both values will increase at higher voltages. The input current value can be increased above 60A, if heat sinks are installed, see parts list below.

The switching frequency is 250kHz and at a 24V input to 48V_{OUT} at full load, the efficiency of DC2896A-B is 98%. As the input voltage decreases, the output current should be decreased as well, to prevent saturation of the DC2896A-B inductors, the derating curve presented on Figure 3. Efficiency curves presented on Figure 4.

DC2896A-B resistors R114 to R119 program the phase relationship between the power sections, by setting the Total Distinct Phase Number (TDPN). For increasing efficiency and reducing switching losses at light loads DC2896A-B supports disconnecting some power sections. This mode of operation designated as the stage shedding and it is programmed by the jumper J3 STAGE SHED. Jumper JP1 programs the LT8551 SYNC pin and it allows DC2896A-B to be synchronized to an external clock. The print circuit board of DC2896A also supports

two phase expander controllers, the [LT8561](#) and [LT8551](#), with versions DC2896A-A and DC2896A-B correspondingly. The table [1] in the electrical schematic describes differences between both versions, including controller biasing and gate drive voltages.

DC2896A-B has jumper SHDN (JP2) for manually enable or disable controller. The SYNC (E19) input can be used to sync LT8551 with an external signal. There are also terminals that make it easy to monitor the control logic of the LT8551 functional. The current sense resistors R_{SNS1} to R_{SNS5} used for implementation of current mode control, monitoring and sharing current between the phases. To further increase efficiency DC2896A-B supports optional DCR sensing of inductors L1 to L5

DC2896A-B includes sense line filters and filter options for inputs to the LT8551 in accordance with data sheet recommendations. Undervoltage shutdown, switching frequency and LT8551 ILIM current limit levels can all be adjusted by resistors or resistor jumpers. DC2896A-B comes with a housekeeping circuit based on U3 controller. It reduces the power dissipation that would otherwise occur at high input voltages in regulator transistor Q21. The housekeeping circuit also stabilizes converter biasing at sudden input voltage drops.

A high level of available output power without a corresponding high level of design complexity makes the LT8551 attractive for high power DC bus and battery systems in commercial, industrial and automotive settings. DC2896A-B features the LT8551EUKG in a thermally enhanced 52-pin 7mm × 8mm QFN package. The LT8551 and LTC3769 data sheets must be read in conjunction with this demo manual to properly use or modify DC2896A-B.

Design files for this circuit board are available.

All registered trademarks and trademarks are the property of their respective owners.

DEMO MANUAL DC2896A-B

PERFORMANCE SUMMARY Specifications are at $T_A = 25^\circ\text{C}$

PARAMETER	CONDITIONS	MIN	TYP	MAX	UNITS
Minimum Input Voltage, V_{IN}				10	V
Maximum Input Voltage, V_{IN}		46			V
Output Voltage, V_{OUT}			48		V
Input Current, I_{IN}				60	A
Efficiency	$V_{IN} = 24\text{V}$, $I_{OUT} = 30\text{A}$		98		%
Switching Frequency		250			kHz

QUICK START PROCEDURE

To evaluate the performance of DC2896A-B follow procedure below.

1. Read LT8551 data sheet, conduct visual inspection of DC2896A-B, locating input/output terminals and control jumpers.
2. Prepare to use the SHDN terminal to control the startup. Connect the SHDN terminal to GND by setting jumper SHDN (JP2) into OFF position.
3. Set the STAGE SHED MODE jumper JP3 to ENABLE if phase shedding is desired or to DESABLE if phase shedding is not desired.
4. Set the SYNC jumper JP1 to fixed frequency by inserting jumper into FIX FQ position.
5. Check the phase selection, TDPN SET, by inspecting connections resistors R114 to R119.
6. Connect the input power supply with power off, load and meters as shown on Figure 1.
7. Make sure that input power supply is 1,600W and output current at least 70A, the same related to load, it should be at least 1,600W and 60V rating.
8. After connections are made, turn on the input power supply and verify that input voltage between 12V and 46V.
9. Set output load to 0A.
10. Set jumper SHDN (JP2) into ON position, you should observe 48V on the output terminals and the load.
11. Once the proper output voltage is established, adjust the load and observe the output voltage regulation, ripple voltage, efficiency and other parameters.

NOTE: If the output voltage is low, try startup again using SHDN with the load disconnected. The load may cause low output if some of the DC2896A-B power sections are inadvertently disconnected and not able to deliver power. It is possible the input supply may current limit and cause DC2896A-B to have low output. In more extreme cases it is possible that the load may be set too high for DC2896A-B.

QUICK START PROCEDURE

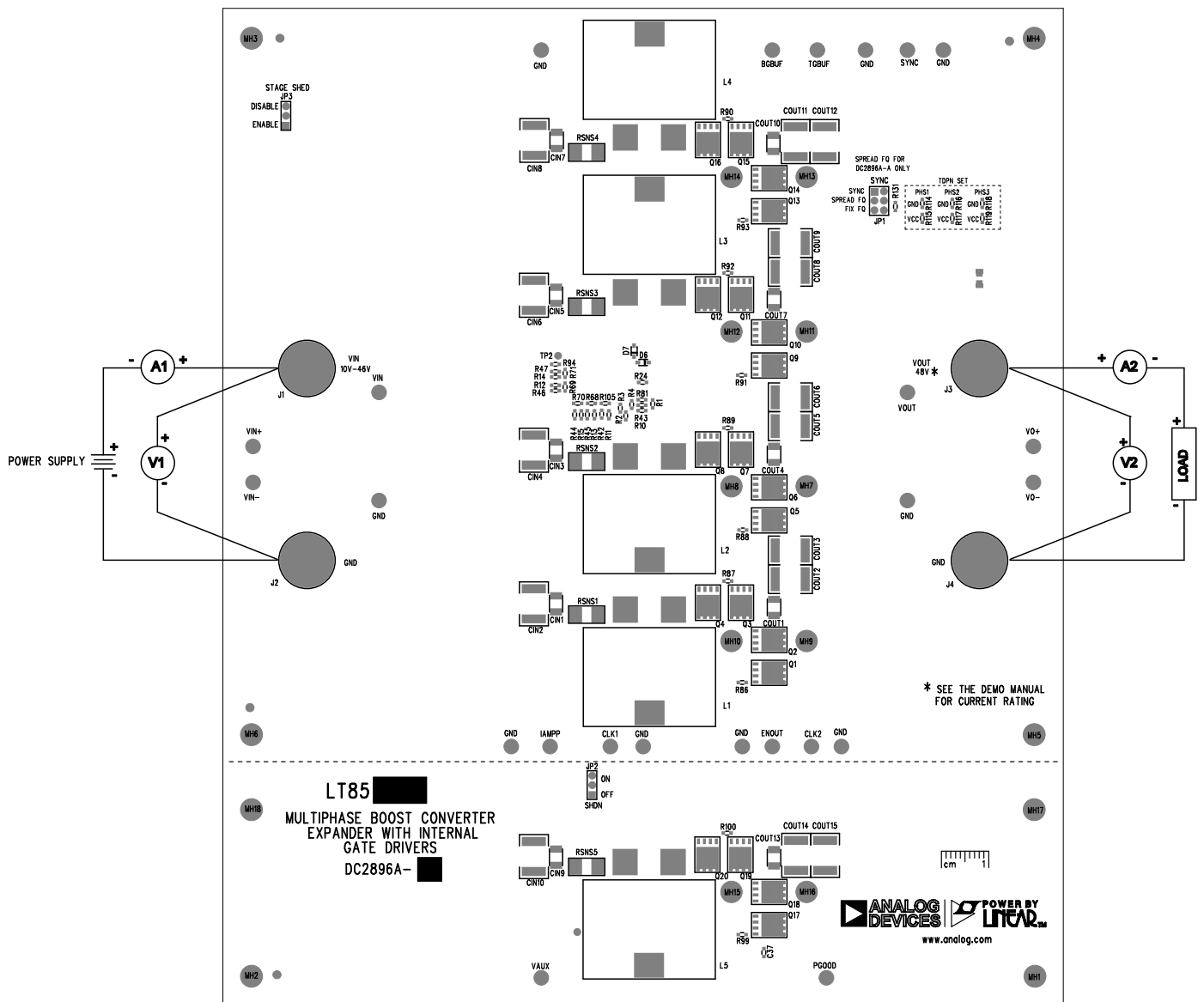

Figure 1. Proper Equipment Setup for DC2896A-B

QUICK START PROCEDURE

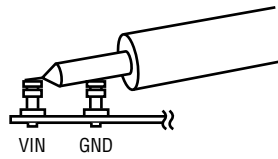

Figure 2. Measuring Input or Output Ripple

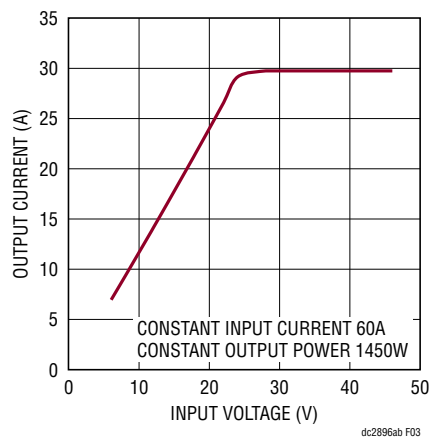

Figure 3. Derating Guidelines, Output Current vs Input Voltage

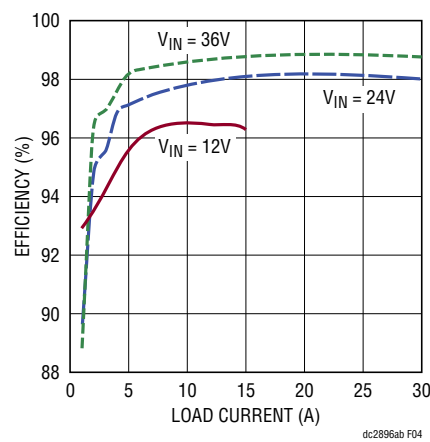

Figure 4. Efficiency vs Output Current and Input Voltage, V_{OUT} Is 48V

QUICK START PROCEDURE

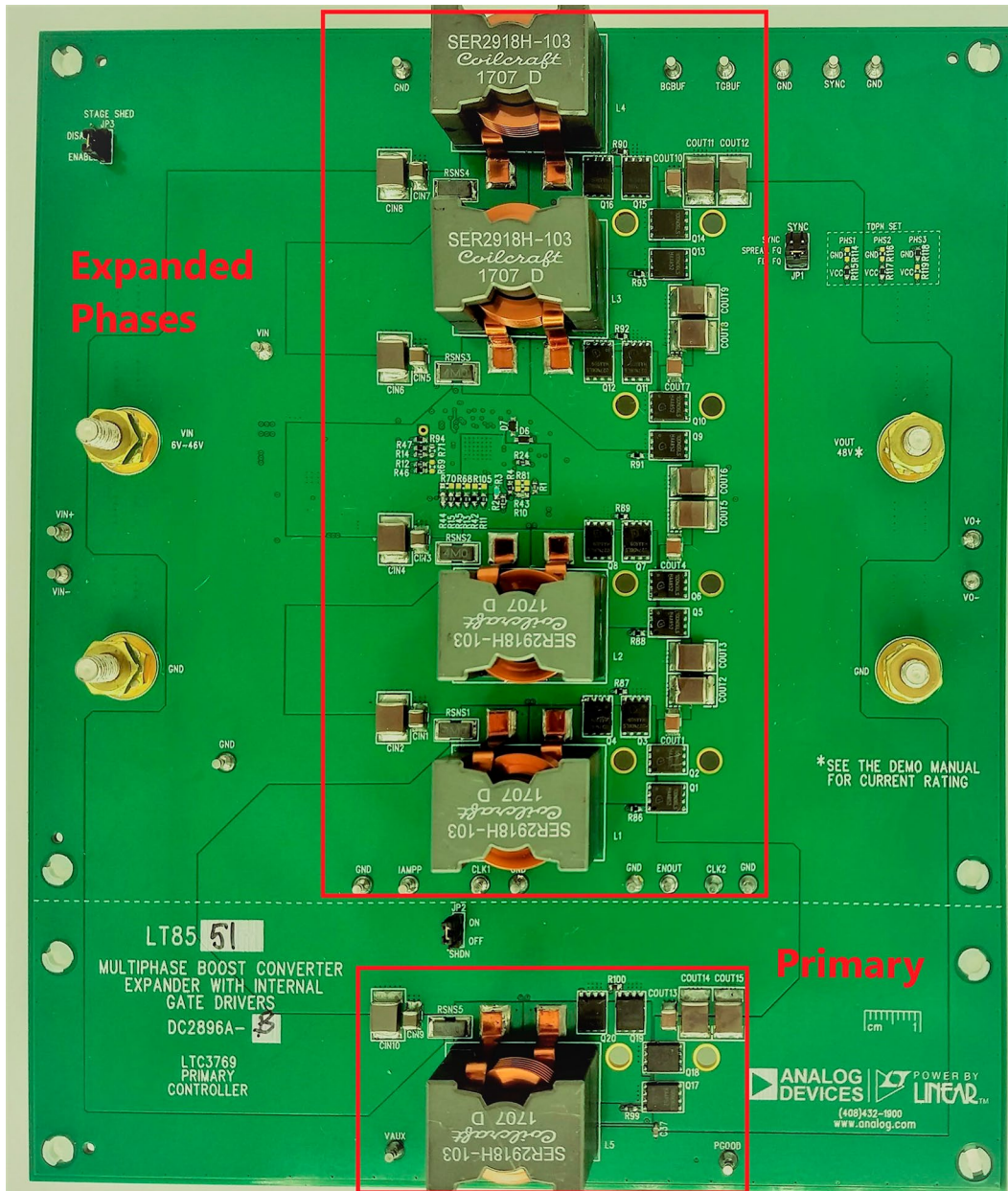

Figure 5. Photo of DC2896A-B with Designated Primary Controller and Phase Expander Power Sections

QUICK START PROCEDURE

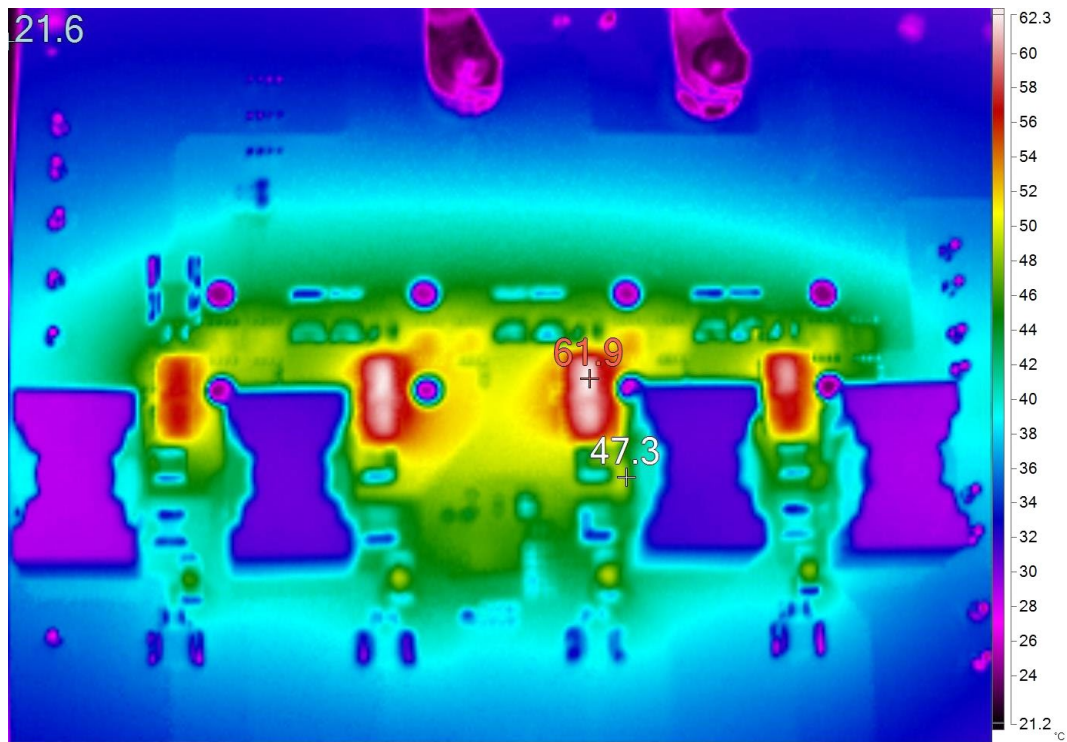

Figure 6. Thermal Map of Four Phases of LT8551 Multiphase Boost Converter Expander. Input Voltage 24V, Output 48V at 25A, Convection Cooling, No Air Flow

PARTS LIST

ITEM	QTY	REFERENCE	PART DESCRIPTION	MANUFACTURER/PART NUMBER
Required Circuit Components				
1	2	C1, C23	CAP., 1 μ F, X7R, 50V, 10%, 1206	AVX, 12065C105KAT2A
2	2	C2, C33	CAP., 2.2 μ F, X5R, 25V, 10%, 0603	MURATA, GRM188R61E225KA12D
3	1	C3	CAP., 10 μ F, X5R, 16V, 10%, 0603	AVX, 0603YD106KAT2A
4	13	C4, C5, C7-C13, C15, C30, C35, C55	CAP., 1000 μ F, X7R, 25V, 10%, 0603	AVX, 06033C102KAT2A
5	1	C6	CAP., 100 μ F, X7R, 16V, 10%, 0603	AVX, 0603YC101KAT2A
6	1	C16	CAP., 10 μ F, ALUM. ELECT., 100V, 20%, 6.3x7.7	SUN ELECTRONIC INDUSTRIES CORP, 100CE10BS
7	5	C17-C20, C22	CAP., 0.22 μ F, X5R, 16V, 10%, 0603	AVX, 0603YD224KAT2A
8	4	C21, C27, C34, C37	CAP., 0.1 μ F, X7R, 50V, 10%, 0603	AVX, 06035C104KAT2A
9	1	C24	CAP., 1 μ F, X7R, 16V, 10%, 0603	AVX, 0603YC105KAT2A
10	1	C25	CAP., 1 μ F, X5R, 25V, 10%, 0603	AVX, 06033D105KAT2A
11	1	C26	CAP., 4.7 μ F, C0G, 25V, 10%, 0603	AVX, 06033A4R7KAT2A
12	1	C28	CAP., 2.2 μ F, X7R, 100V, 10%, 1210	AVX, 12101C225KAT2A
13	1	C29	CAP., 4.7 μ F, X7R, 25V, 10%, 0805	AVX, 08053C475KAT2A
14	1	C31	CAP., 0.015 μ F, X7R, 25V, 10%, 0603	AVX, 06033C153KAT2A
15	1	C32	CAP., 47 μ F, X5R, 16V, 20%, 1210	AVX, 1210YD476MAT2A
16	2	C36, C57	CAP., 0.01 μ F, X7R, 16V, 10%, 0603	AVX, 0603YC103KAT2A
17	1	C58	CAP., 22 μ F, C0G, 50V, 5%, 0603	AVX, 06035A220JAT2A
18	2	C60, C61	CAP., 100 μ F, ALUM. ELECT., 100V, 20%, 16x16.5mm SMD, RADIAL, Sn PLATING	SUN ELECTRONIC INDUSTRIES CORP, 100CE100BST
19	2	C62, C63	CAP., 1000 μ F, ALUM. ELECT., 50V, 20%, 16x16.5mm SMD, RADIAL, AEC-Q200	PANASONIC, EEEFK1H102AM
20	5	CIN1, CIN3, CIN5, CIN7, CIN9	CAP., 10 μ F, X7R, 63V, 10%, 1210	SAMSUNG, CL32B106KMVNNWE
21	15	CIN2, CIN4, CIN6, CIN8, CIN10, COUT2, COUT3, COUT5, COUT6, COUT8, COUT9, COUT11, COUT12, COUT14, COUT15	CAP., 15 μ F, X7S, 100V, 20%, 2220, AEC-Q200	TDK, CGA9P3X7S2A156M250KB
22	5	COUT1, COUT4, COUT7, COUT10, COUT13	CAP., 4.7 μ F, X7S, 100V, 10%, 1210	SAMSUNG, CL32Y475KCVZW6E
23	5	D1-D5	DIODE, SCHOTTKY, 70V, 70mA, SOD-323, AEC-Q101	INFINEON, BAS170W
24	2	D6, D7	DIODE, SCHOTTKY, 100V, 250mA, SOD-323F, AEC-Q101	NEXPERIA, BAT46WJ, 115
25	1	D8	DIODE, GP SWITCHING, 80V, 125mA, SOD523, AEC-Q10X	DIODES INC., 1N4448HWT-7
26	4	J1-J4	EVAL BOARD STUD HARDWARE SET, #10-32	ANALOG DEVICES, 720-0010
27	5	L1-L5	IND., 10 μ H, PWR, 10%, 28A, 2.86m Ω , SMD, SHIELDED, AEC-Q200	COILCRAFT, SER2918H-103KL
28	1	L6	IND., 22 μ H, PWR, SHIELDED, 20%, 1.41A, 110m Ω , 7345, AEC-Q200	WURTH ELEKTRONIK, 744779122
29	10	Q1, Q2, Q5, Q6, Q9, Q10, Q13, Q14, Q17, Q18	XSTR., MOSFET, N-CH, 60V, 50A, PG-TDSON-8	INFINEON, BSC100N06LS3 G
30	10	Q3, Q4, Q7, Q8, Q11, Q12, Q15, Q16, Q19, Q20	XSTR., MOSFET, N-CH, 60V, 100A, PG-TDSON-8	INFINEON, BSC027N06LS5
31	1	Q21	XSTR., MOSFET, P-CH, 100V, 3.7A, SOT-223-4L, AEC-Q101	DIODES INC., ZXMP10A18GTA

DEMO MANUAL DC2896A-B

PARTS LIST

ITEM	QTY	REFERENCE	PART DESCRIPTION	MANUFACTURER/PART NUMBER
32	2	R1, R2	RES., 100k, 1%, 1/10W, 0603, AEC-Q200	PANASONIC, ERJ3EKF1003V
33	1	R3	RES., 14.3k, 1%, 1/10W, 0603, AEC-Q200	VISHAY, CRCW060314K3FKEA
34	3	R4, R9, R16	RES., 47k, 1%, 1/10W, 0603, AEC-Q200	NIC, NRC06F4702TRF
35	9	R7, R11-R15, R21, R24, R25	RES., 10 Ω , 1%, 1/10W, 0603	VISHAY, CRCW060310R0FKEA
36	1	R8	RES., 20 Ω , 5%, 1/10W, 0603, AEC-Q200	VISHAY, CRCW060320R0JNEA
37	1	R17	RES., 12.1k, 1%, 1/10W, 0603, AEC-Q200	PANASONIC, ERJ3EKF1212V
38	1	R18	RES., 464k, 1%, 1/10W, 0603	SAMSUNG, RC1608F4643CS
39	1	R19	RES., 7.87k, 1%, 1/10W, 0603, AEC-Q200	PANASONIC, ERJ3EKF7871V
40	1	R20	RES., 10k, 1%, 1/10W, 0603	VISHAY, CRCW060310K0FKEC
41	1	R26	RES., 10k, 1%, 1/10W, 0603, AEC-Q200	PANASONIC, ERJ3EKF1002V
42	1	R27	RES., 25.5k, 1%, 1/10W, 0603, AEC-Q200	PANASONIC, ERJ3EKF2552V
43	1	R28	RES., 162k, 1%, 1/10W, 0603, AEC-Q200	PANASONIC, ERJ3EKF1623V
44	2	R29, R61	RES., 1M, 1%, 1/10W, 0603, AEC-Q200	VISHAY, CRCW06031M00FKEA
45	1	R34	RES., 2 Ω , 1%, 1/10W, 0603	VISHAY, CRCW06032R00FNEA
46	1	R42	RES., 0 Ω , 1/10W, 0603	BOURNS, CR0603-J/-000ELF
47	1	R82	RES., 40.2k, 1%, 1/10W, 0603, AEC-Q200	NIC, NRC06F4022TRF
48	5	RSNS1-RSNS5	RES., 0.004 Ω , 1%, 3W, 2512, METAL, SENSE, AEC-Q200	PANASONIC, ERJMS4SF4M0U
49	1	U1	IC, GATE DRIVER BOOST CONVERTER, QFN-52	ANALOG DEVICES, LT8551EUKG#PBF
50	1	U2	IC, 60V LOW I _Q SYNCH. BOOST CTRLR., QFN-24 (UF)	ANALOG DEVICES, LTC3769EUF#PBF
51	1	U3	IC, SYNCH. μ POWER STEP-DOWN REG., TSSOP-20 (FE16), 100V, 1A	ANALOG DEVICES, LT8631EFE#PBF

Additional Demo Board Circuit Components

1	0	C14, C38-C51, C53, C54, C56	CAP., OPTION, 0603	
2	33	R5, R10, R22, R44-R47, R64-R67, R86-R94, R99-R101, R112, R115, R117, R118, R121-R124, R129, R131	RES., 0 Ω , 1/10W, 0603	BOURNS, CR0603-J/-000ELF
3	0	R43, R50-R52, R54, R55, R68-R71, R76-R79, R81, R84, R85, R104, R105, R111, R113, R114, R116, R119, R120, R126, R128, R130	RES., OPTION, 0603	
4	0	R72-R75, R83	RES., OPTION, 0805	

Hardware: For Demo Board Only

1	24	E1, E2, E4, E7, E9-E12, E16, E17, E19, E22, E28, E29, E34-E38, E40-E44	TEST POINT, TURRET, 0.064" MTG. HOLE, PCB 0.062" THK	MILL-MAX, 2308-2-00-80-00-00-07-0
2	1	JP1	CONN., HDR., MALE, 2x3, 2mm, VERT, ST, THT	WURTH ELEKTRONIK, 62000621121
3	2	JP2, JP3	CONN., HDR., MALE, 1x3, 2mm, VERT, ST, THT, NO SUBS. ALLOWED	WURTH ELEKTRONIK, 62000311121
4	4	MP1-MP4	STANDOFF, NYLON, SNAP-ON, 0.625 (5/8"), 15.9mm	KEYSTONE, 8834
5	3	XJP1-XJP3	CONN., SHUNT, FEMALE, 2 POS, 2mm	WURTH ELEKTRONIK, 60800213421

SCHEMATIC DIAGRAM

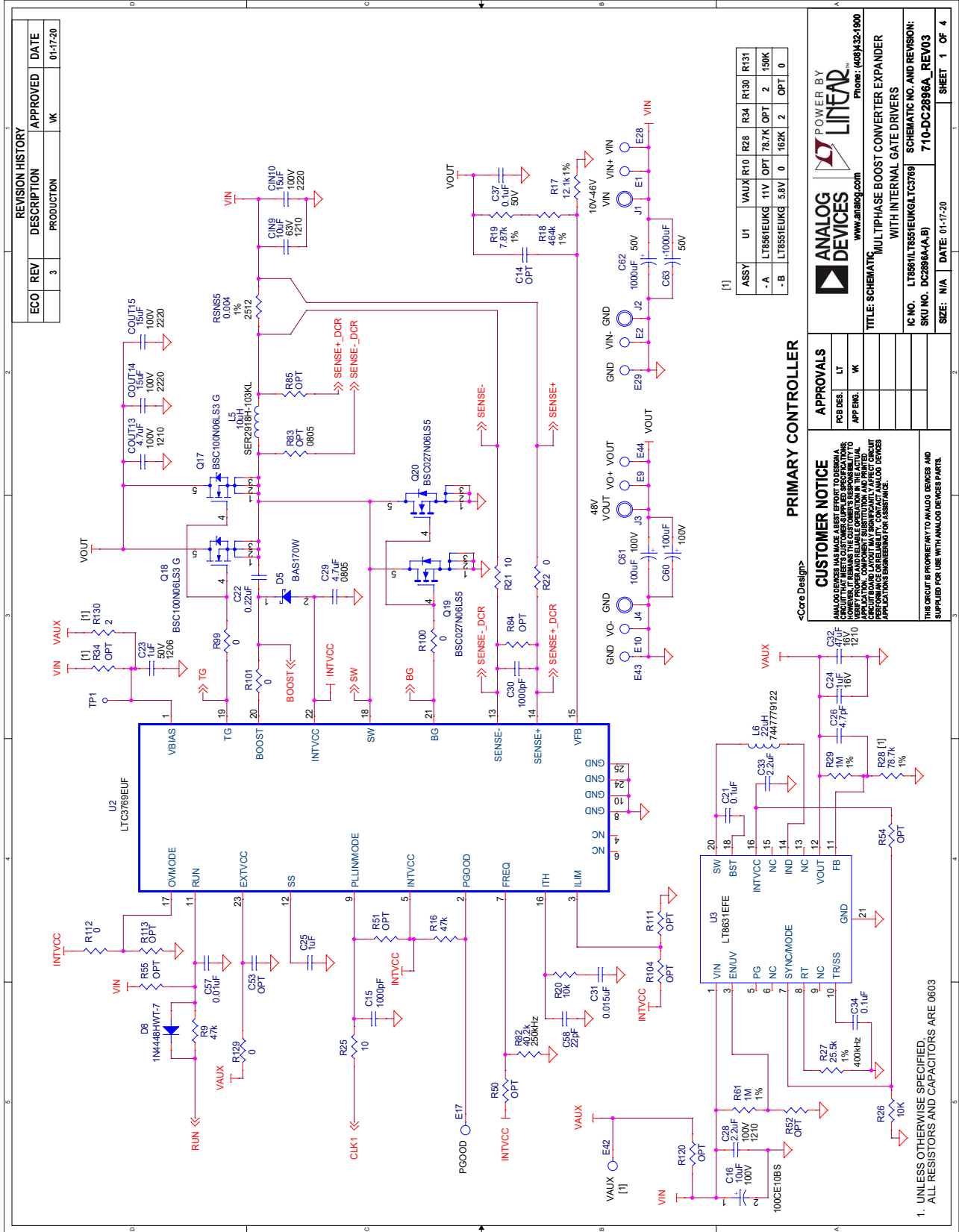

REVISION HISTORY				
ECO	REV	DESCRIPTION	APPROVED	DATE
	3	PRODUCTION	JK	01-17-20

ASSY	U1	VAUX	R10	R28	R34	R130	R131
-A	LT8561EUKG	11V	OPT	78.7K	2	150K	
-B	LT8561EUKG	5.8V	0	162K	2	OPT	0

ANALOG DEVICES POWER BY **LINEAR**

www.analog.com Phone: (603) 432-9900

TITLE: SCHEMATIC WITH INTERNAL GATE DRIVERS

IC NO. LT8561EUKG(LTC3769) SCHEMATIC NO. AND REVISION: 710-DC2896A_REV03

SKU NO. DC2896A-A-B) DATE: 01-17-20 SIZE: N/A SHEET 1 OF 4

PRIMARY CONTROLLER

<Core Design>

CUSTOMER NOTICE
ANALOG DEVICES MAKES A BEST EFFORT TO DESIGN A BOARD THAT MEETS THE CUSTOMER'S REQUIREMENTS. HOWEVER, IT REMAINS THE CUSTOMER'S RESPONSIBILITY TO VERIFY PROPER AND RELIABLE OPERATION IN THE ACTUAL APPLICATION. ANALOG DEVICES DOES NOT WARRANT ANY PERFORMANCE OR EFFECT CIRCUIT APPLICATIONS ENGINEERING FOR ASSISTANCE.

APPROVALS

PRE DES.	LT
APP ENG.	JK

THIS CIRCUIT IS PROPRIETARY TO ANALOG DEVICES AND SUPPLIED FOR USE WITH ANALOG DEVICES PARTS.

1. UNLESS OTHERWISE SPECIFIED, ALL RESISTORS AND CAPACITORS ARE 0603



SCHEMATIC DIAGRAM

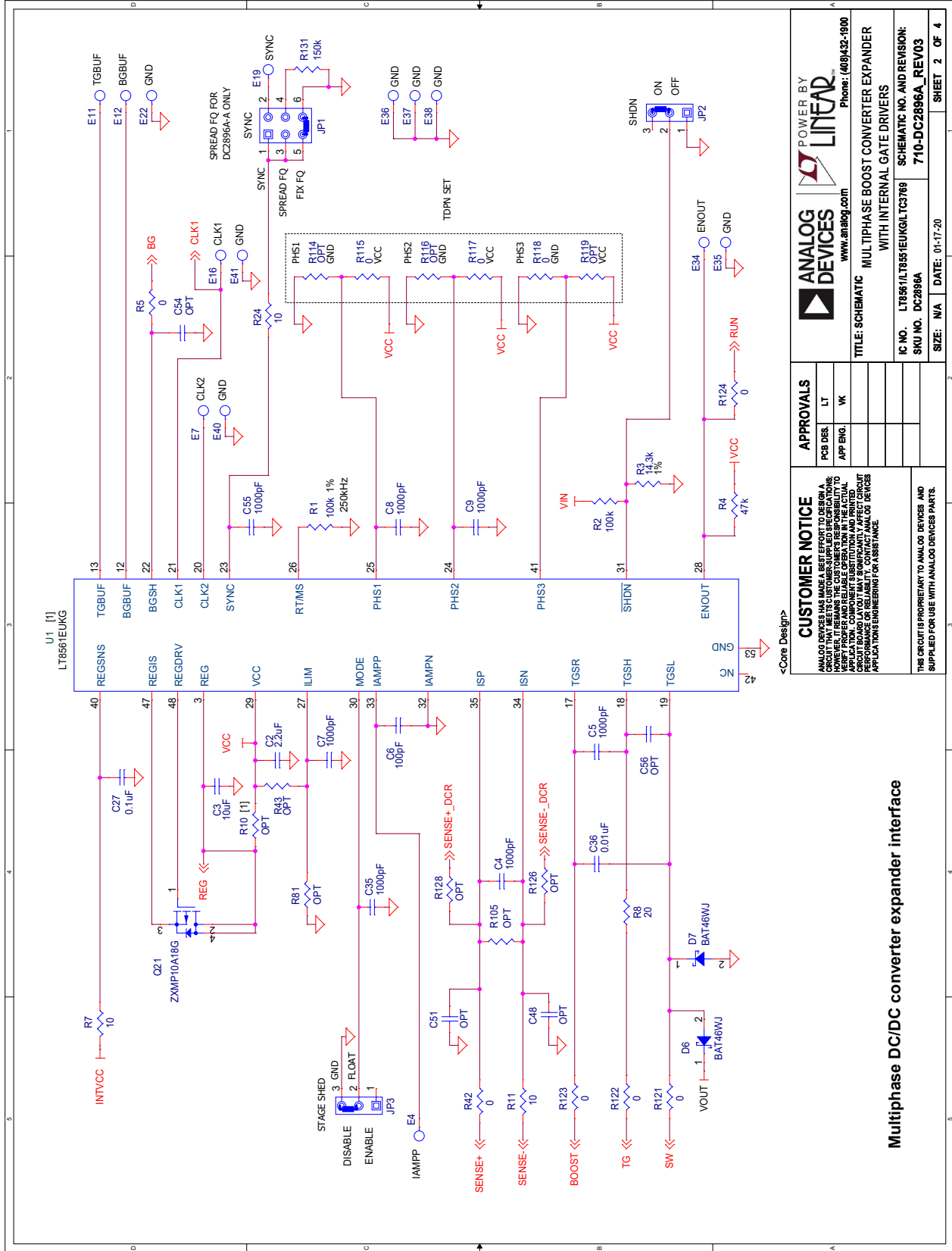

Multiphase DC/DC converter expander interface

SCHEMATIC DIAGRAM

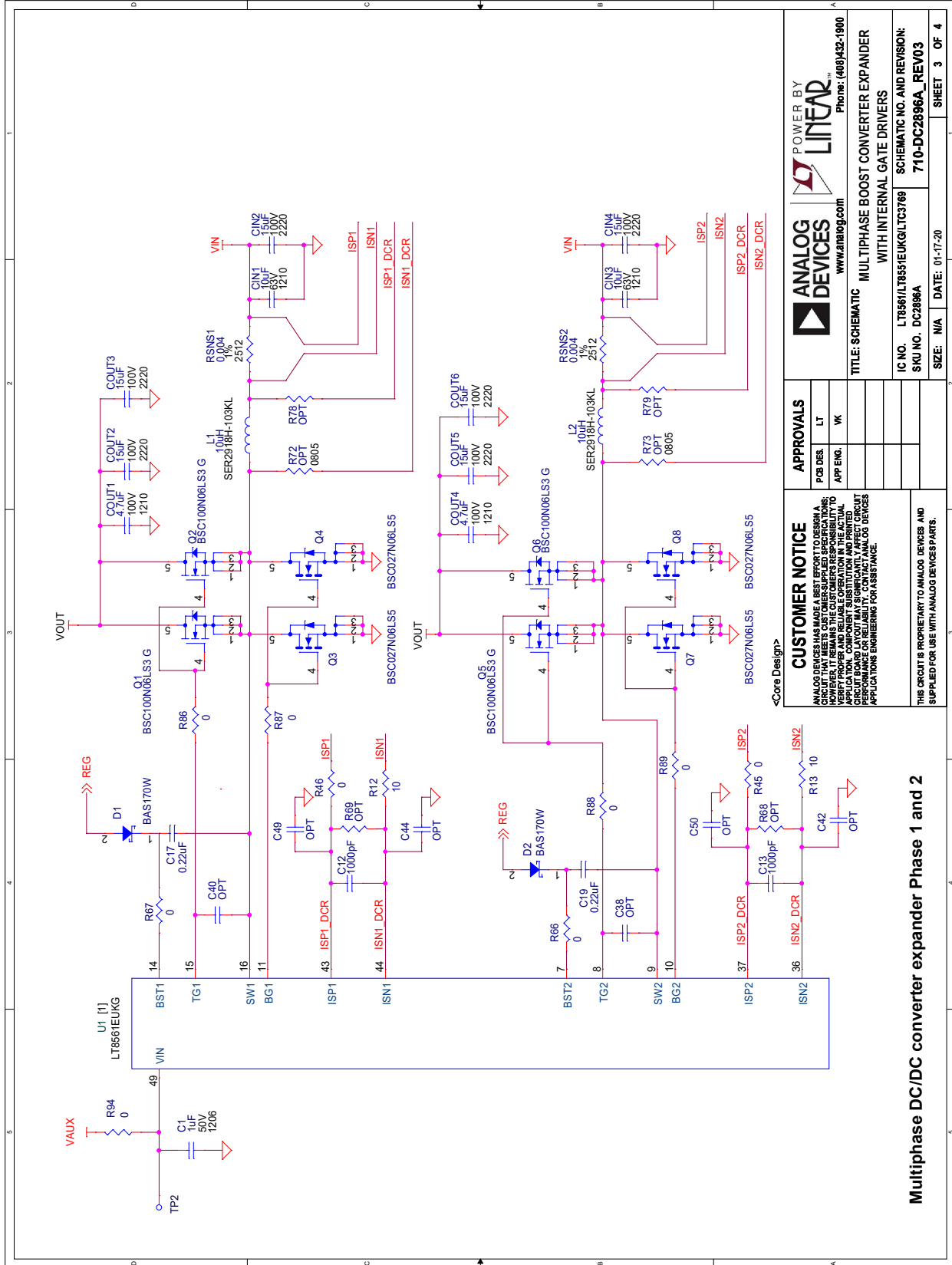

Multiphase DC/DC converter expander Phase 1 and 2

www.analog.com		Phone: (408)432-1900	
TITLE: SCHEMATIC MULTIPHASE BOOST CONVERTER EXPANDER WITH INTERNAL GATE DRIVERS			
IC NO. LT1856/LT1856EUKG/LTC3769		SCHEMATIC NO. AND REVISION: 710-DC2896A_REV03	
SKU NO. DC2896A		DATE: 01-17-20	
SIZE: N/A		SHEET 3 OF 4	
CUSTOMER NOTICE ANALOG DEVICES HAS MADE A BEST EFFORT TO DESIGN AND VERIFY THE PROPER AND RELIABLE OPERATION IN THE ACTUAL CIRCUIT BOARD LAYOUT MAY SIGNIFICANTLY AFFECT CIRCUIT PERFORMANCE OR RELIABILITY. CONTACT ANALOG DEVICES APPLICATIONS ENGINEERING FOR ASSISTANCE.		APPROVALS PCB DES: LT APP ENG: VK	
THIS CIRCUIT IS PROPRIETARY TO ANALOG DEVICES AND SUPPLIED FOR USE WITH ANALOG DEVICES PARTS.			

SCHEMATIC DIAGRAM

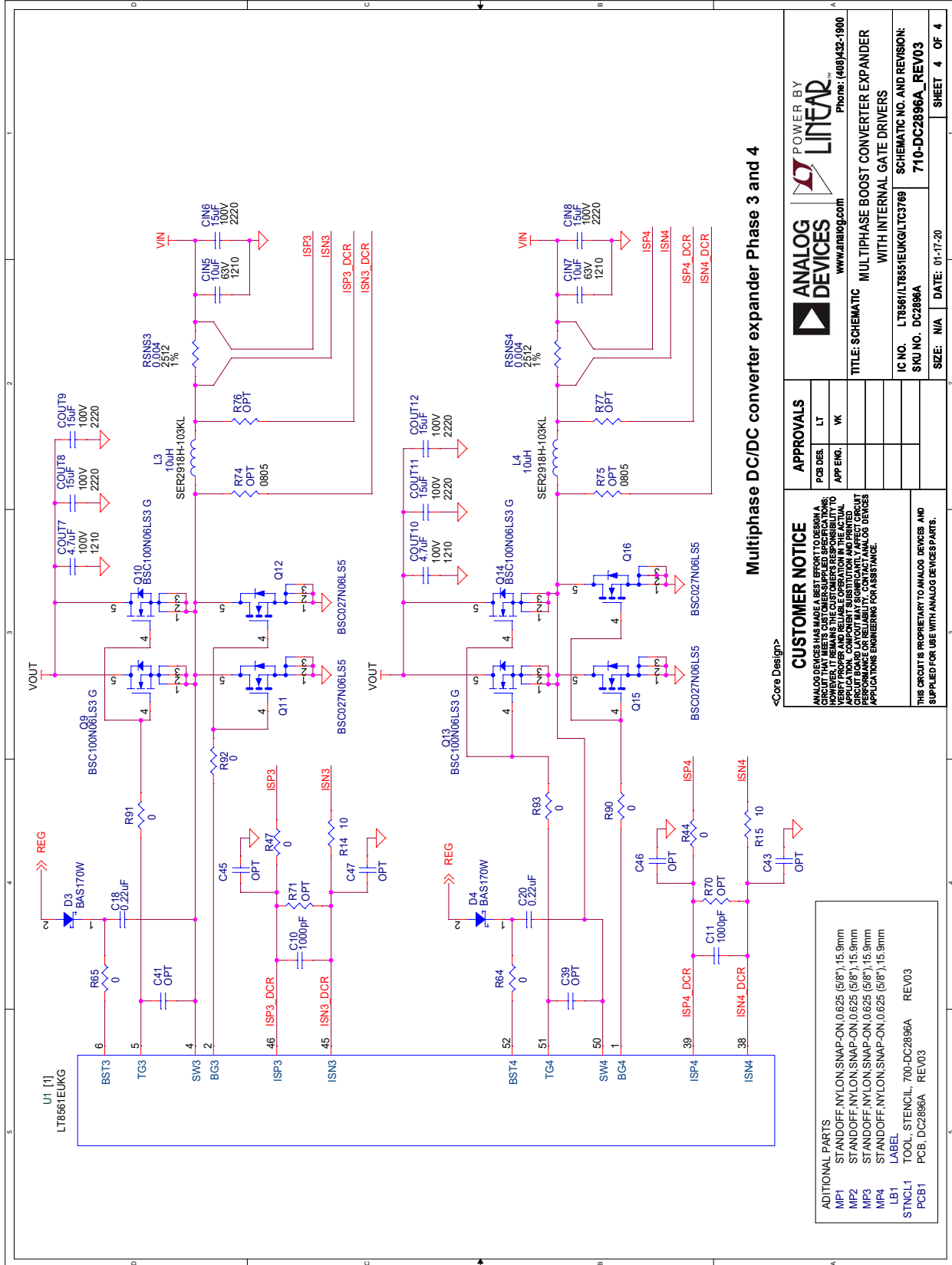

Multiphase DC/DC converter expander Phase 3 and 4

www.analog.com		Phone: (408)432-1900	
TITLE: SCHEMATIC			
MULTIPHASE BOOST CONVERTER EXPANDER WITH INTERNAL GATE DRIVERS			
IC NO. LT8561/1TB851EUKG/LTC3769		SCHEMATIC NO. AND REVISION: 710-DC2896A_REV03	
SKU NO. DC2896A		DATE: 01-17-20	
SIZE: N/A		SHEET 4 OF 4	
APPROVALS		PCB DES: LT APP ENG: VK	
CUSTOMER NOTICE ANALOG DEVICES HAS MADE A BEST EFFORT DESIGN AND TESTING OF THIS SCHEMATIC. HOWEVER, IT REMAINS THE CUSTOMER'S RESPONSIBILITY TO VERIFY PROPER AND RELIABLE OPERATION IN THE ACTUAL CIRCUIT BOARD LAYOUT. BOARD LAYOUT MAY SIGNIFICANTLY AFFECT CIRCUIT PERFORMANCE OR RELIABILITY. CONTACT ANALOG DEVICES APPLICATIONS ENGINEERING FOR ASSISTANCE.			
THIS CIRCUIT IS PROPRIETARY TO ANALOG DEVICES AND SUPPLIED FOR USE WITH ANALOG DEVICES PARTS.			

ADDITIONAL PARTS

- MP1 STANDOFF, NYLON, SNAP-ON, 0.625 (6/8"), 15.9mm
- MP2 STANDOFF, NYLON, SNAP-ON, 0.625 (6/8"), 15.9mm
- MP3 STANDOFF, NYLON, SNAP-ON, 0.625 (6/8"), 15.9mm
- MP4 STANDOFF, NYLON, SNAP-ON, 0.625 (6/8"), 15.9mm
- LB1 LABEL
- STNCL1 TOOL, STENCIL, 700-DC2896A
- PCB1 PCB, DC2896A

REV03

SCHEMATIC DIAGRAM

<p style="text-align: center;"></variant Name></p> <p>MP1 STANDOFF,NYLON,SNAP-ON,0.625 (5/8"),15.9mm MP2 STANDOFF,NYLON,SNAP-ON,0.625 (5/8"),15.9mm MP3 STANDOFF,NYLON,SNAP-ON,0.625 (5/8"),15.9mm MP4 STANDOFF,NYLON,SNAP-ON,0.625 (5/8"),15.9mm LB1 LABEL STNCL1 TOOL,STENCIL,700-DC2896A REV02 PCB1 PCB,DC2896A REV02</p>	<table border="1" style="width: 100%; border-collapse: collapse;"> <tr> <td style="text-align: center;">ANALOG DEVICES</td> <td style="text-align: center;">POWER BY LINEAR™</td> </tr> <tr> <td style="text-align: center;">www.analog.com</td> <td style="text-align: center;">Phone: (408)832-1900</td> </tr> <tr> <td colspan="2" style="text-align: center;">TITLE: SCHEMATIC MULTIPHASE BOOST CONVERTER EXPANDER WITH INTERNAL GATE DRIVERS</td> </tr> <tr> <td style="text-align: center;">IC NO. L78561/L78561EUK/LTC3769</td> <td style="text-align: center;">SCHEMATIC NO. AND REVISION: 710-DC2896A_REV01</td> </tr> <tr> <td style="text-align: center;">SIZE: N/A</td> <td style="text-align: center;">DATE: 09-05-19</td> </tr> <tr> <td colspan="2" style="text-align: right;">SHEET 5 OF 4</td> </tr> </table>	ANALOG DEVICES	POWER BY LINEAR™	www.analog.com	Phone: (408)832-1900	TITLE: SCHEMATIC MULTIPHASE BOOST CONVERTER EXPANDER WITH INTERNAL GATE DRIVERS		IC NO. L78561/L78561EUK/LTC3769	SCHEMATIC NO. AND REVISION: 710-DC2896A_REV01	SIZE: N/A	DATE: 09-05-19	SHEET 5 OF 4	
ANALOG DEVICES	POWER BY LINEAR™												
www.analog.com	Phone: (408)832-1900												
TITLE: SCHEMATIC MULTIPHASE BOOST CONVERTER EXPANDER WITH INTERNAL GATE DRIVERS													
IC NO. L78561/L78561EUK/LTC3769	SCHEMATIC NO. AND REVISION: 710-DC2896A_REV01												
SIZE: N/A	DATE: 09-05-19												
SHEET 5 OF 4													
<p>CUSTOMER NOTICE ANALOG DEVICES HAS MADE A BEST EFFORT TO DESCRIBE THE PARTS AND MATERIALS LISTED IN THIS DEMO MANUAL. HOWEVER, IT REMAINS THE CUSTOMER'S RESPONSIBILITY TO VERIFY PROPER AND RELIABLE OPERATION IN THE ACTUAL CIRCUIT BOARD LAYOUT MAY SIGNIFICANTLY AFFECT CIRCUIT PERFORMANCE OR RELIABILITY. CONTACT ANALOG DEVICES APPLICATIONS ENGINEERING FOR ASSISTANCE.</p> <p>THIS CIRCUIT IS PROPRIETARY TO ANALOG DEVICES AND SUPPLIED FOR USE WITH ANALOG DEVICES PARTS.</p>	<table border="1" style="width: 100%; border-collapse: collapse;"> <tr> <td style="text-align: center;">APPROVALS</td> </tr> <tr> <td>PCB DES: LIT</td> </tr> <tr> <td>APP ENG: VK</td> </tr> <tr> <td> </td> </tr> <tr> <td> </td> </tr> <tr> <td> </td> </tr> <tr> <td> </td> </tr> </table>	APPROVALS	PCB DES: LIT	APP ENG: VK									
APPROVALS													
PCB DES: LIT													
APP ENG: VK													



ESD Caution

ESD (electrostatic discharge) sensitive device. Charged devices and circuit boards can discharge without detection. Although this product features patented or proprietary protection circuitry, damage may occur on devices subjected to high energy ESD. Therefore, proper ESD precautions should be taken to avoid performance degradation or loss of functionality.

Legal Terms and Conditions

By using the evaluation board discussed herein (together with any tools, components documentation or support materials, the "Evaluation Board"), you are agreeing to be bound by the terms and conditions set forth below ("Agreement") unless you have purchased the Evaluation Board, in which case the Analog Devices Standard Terms and Conditions of Sale shall govern. Do not use the Evaluation Board until you have read and agreed to the Agreement. Your use of the Evaluation Board shall signify your acceptance of the Agreement. This Agreement is made by and between you ("Customer") and Analog Devices, Inc. ("ADI"), with its principal place of business at One Technology Way, Norwood, MA 02062, USA. Subject to the terms and conditions of the Agreement, ADI hereby grants to Customer a free, limited, personal, temporary, non-exclusive, non-sublicensable, non-transferable license to use the Evaluation Board FOR EVALUATION PURPOSES ONLY. Customer understands and agrees that the Evaluation Board is provided for the sole and exclusive purpose referenced above, and agrees not to use the Evaluation Board for any other purpose. Furthermore, the license granted is expressly made subject to the following additional limitations: Customer shall not (i) rent, lease, display, sell, transfer, assign, sublicense, or distribute the Evaluation Board; and (ii) permit any Third Party to access the Evaluation Board. As used herein, the term "Third Party" includes any entity other than ADI, Customer, their employees, affiliates and in-house consultants. The Evaluation Board is NOT sold to Customer; all rights not expressly granted herein, including ownership of the Evaluation Board, are reserved by ADI. CONFIDENTIALITY. This Agreement and the Evaluation Board shall all be considered the confidential and proprietary information of ADI. Customer may not disclose or transfer any portion of the Evaluation Board to any other party for any reason. Upon discontinuation of use of the Evaluation Board or termination of this Agreement, Customer agrees to promptly return the Evaluation Board to ADI. ADDITIONAL RESTRICTIONS. Customer may not disassemble, decompile or reverse engineer chips on the Evaluation Board. Customer shall inform ADI of any occurred damages or any modifications or alterations it makes to the Evaluation Board, including but not limited to soldering or any other activity that affects the material content of the Evaluation Board. Modifications to the Evaluation Board must comply with applicable law, including but not limited to the RoHS Directive. TERMINATION. ADI may terminate this Agreement at any time upon giving written notice to Customer. Customer agrees to return to ADI the Evaluation Board at that time. LIMITATION OF LIABILITY. THE EVALUATION BOARD PROVIDED HEREUNDER IS PROVIDED "AS IS" AND ADI MAKES NO WARRANTIES OR REPRESENTATIONS OF ANY KIND WITH RESPECT TO IT. ADI SPECIFICALLY DISCLAIMS ANY REPRESENTATIONS, ENDORSEMENTS, GUARANTEES, OR WARRANTIES, EXPRESS OR IMPLIED, RELATED TO THE EVALUATION BOARD INCLUDING, BUT NOT LIMITED TO, THE IMPLIED WARRANTY OF MERCHANTABILITY, TITLE, FITNESS FOR A PARTICULAR PURPOSE OR NON-INFRINGEMENT OF INTELLECTUAL PROPERTY RIGHTS. IN NO EVENT WILL ADI AND ITS LICENSORS BE LIABLE FOR ANY INCIDENTAL, SPECIAL, INDIRECT, OR CONSEQUENTIAL DAMAGES RESULTING FROM CUSTOMER'S POSSESSION OR USE OF THE EVALUATION BOARD, INCLUDING BUT NOT LIMITED TO LOST PROFITS, DELAY COSTS, LABOR COSTS OR LOSS OF GOODWILL. ADI'S TOTAL LIABILITY FROM ANY AND ALL CAUSES SHALL BE LIMITED TO THE AMOUNT OF ONE HUNDRED US DOLLARS (\$100.00). EXPORT. Customer agrees that it will not directly or indirectly export the Evaluation Board to another country, and that it will comply with all applicable United States federal laws and regulations relating to exports. GOVERNING LAW. This Agreement shall be governed by and construed in accordance with the substantive laws of the Commonwealth of Massachusetts (excluding conflict of law rules). Any legal action regarding this Agreement will be heard in the state or federal courts having jurisdiction in Suffolk County, Massachusetts, and Customer hereby submits to the personal jurisdiction and venue of such courts. The United Nations Convention on Contracts for the International Sale of Goods shall not apply to this Agreement and is expressly disclaimed.