

# Poke-Home: Micro Single Vertical Contact

## 22-26 AWG: WTB

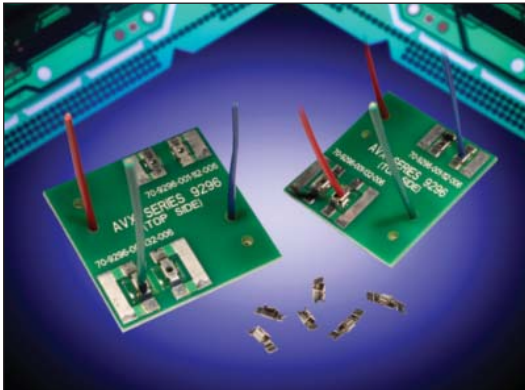

70-9296



AVX continues to develop innovative connectors for the industrial electronics market that provide significant benefits over existing, outdated connector solutions. The latest release is single vertical Wire-to-Board (WTB) contacts that provide cost effective, yet robust discrete wire termination without the expense of an insulator and assembly costs. This new family of top and bottom entry contacts compliments the existing vertical poke home connectors already on the market, providing a lower cost solution without jeopardizing performance.

The new contacts support both solid and stranded wires ranging from 26AWG down to 22AWG and current ratings as high as 8 amps. Due to the mechanical stiffness of the small contact, 26AWG stranded wires may need to be pre-tinned to facilitate insertion. The set of four contacts provide both top and bottom entry for FR4 and metal core printed circuit boards.

### APPLICATIONS

- Machine Controls: motors, drives, solenoids, sensors, fans and pumps
- Commercial Buildings: controls, security, fire and sensors
- Smart Grid: meters, breakers and panels
- SSL/LED; bulbs, fixtures, signage and streetlights
- Application notes: refer to 201-01-150

### FEATURES AND BENEFITS

- Dual Beam contact provides maximum mechanical stability and wire retention
- Tape and reel packaged for automated SMT placement
- Staged current rating based on AWG, maximum is 8A (22AWG)
- Increased functionality with the single contact placement: multiple contacts and/or specific individual locations

### ELECTRICAL

- Voltage Rating: 300V  
Based on placement distance
- Current Rating: See matrix below

### ENVIRONMENTAL

- Operating Temperature:  
-40°C to +125°C

### MECHANICAL

- Contact Material: Phosphor Bronze
- Contact Plating: Tin over Nickel
- Durability: 5 Cycles

### HOW TO ORDER



Code	Contact Location	Wire Insertion Direction	Recommended For Board Type	Wire Gauges*
102	Top Side	Bottom Entry	FR4	22 AWG - 26 AWG
112	Through Board	Top Entry	FR4	22 AWG - 26 AWG
122	Top Side	Bottom Entry	Metal Based	22 AWG - 26 AWG
132	Through Board	Top Entry	Metal Based	22 AWG - 26 AWG

\* 26 AWG stranded wires may require tinning to aid insertion.



### CURRENT RATING

22AWG	24AWG	26AWG
8A	6A	5A

Certification: UL File #E90723

# Poke-Home: Micro Single Vertical Contact

## 22-26 AWG: WTB

70-9296

70-9296-001-102-006

### 9296 VERTICAL MOUNT SMT CONTACT

#### TOP SIDE CONTACT – BOTTOM ENTRY WIRE (FR4 BOARD)

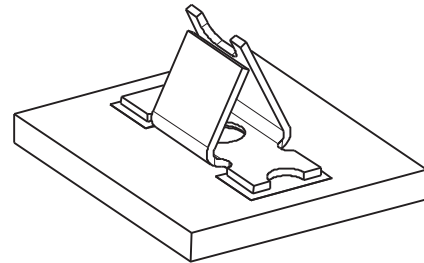
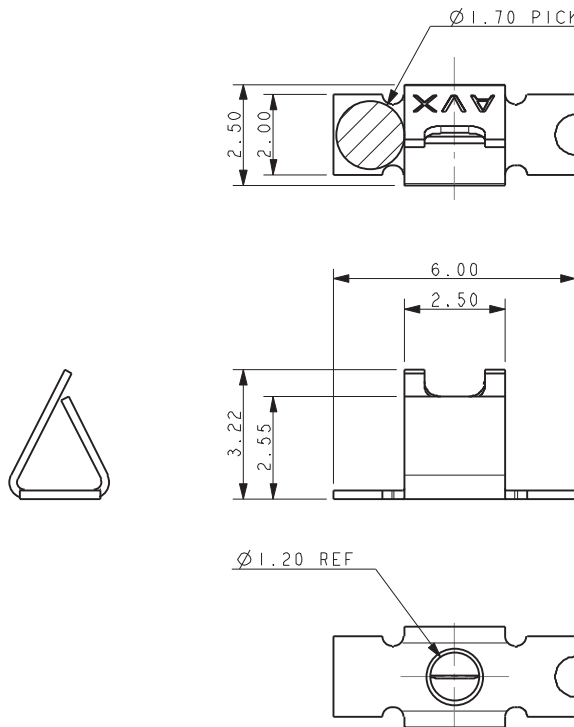

TOP SIDE CONTACT

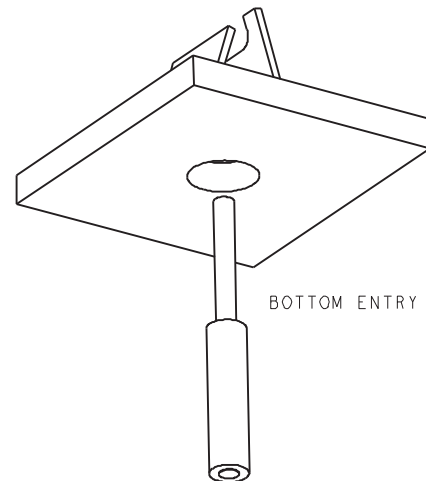

BOTTOM ENTRY WIRE

### SUGGESTED PCB LAYOUT

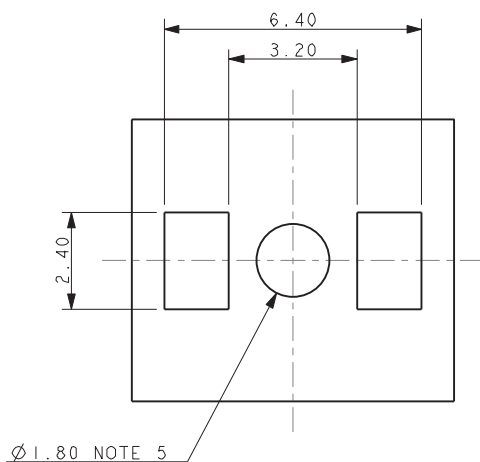

#### NOTES:

- CONTACT MOUNTS ON TOP SIDE OF BOARD, WIRE INSERTED FROM UNDER-SIDE OF BOARD.
- STYLE RECOMMENDED FOR FR4 BOARDS WHERE ADDITIONAL CLEARANCE REQUIRED TO CONTACTS AND MOUNTING PADS.
- FOR FURTHER INFORMATION REFER TO ELCO SPECIFICATION 201-01-161 AND APPLICATION NOTES 201-01-175.
- MATERIAL: TIN PLATED PHOSPHOR BRONZE.
- HOLE FOR WIRE INSERTION.
- PACKING IN TAPE AND REEL, 2000 PIECES PER REEL.
- FOR WIRE TRIM DETAILS REFER TO PAGE 113.
- WIRE SIZES REFER TO PAGE 108.
- GENERAL TOLERANCE  $\pm 0.10$ .
- UL REFERENCE E90723 (US AND CANADA).

### PACKING DETAILS

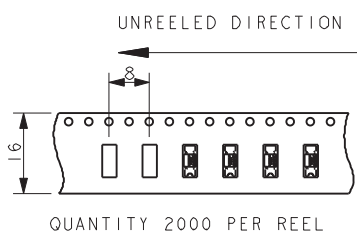

QUANTITY 2000 PER REEL

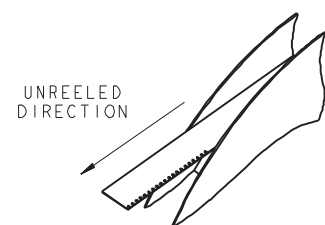

330mm DIAMETER REEL

# Poke-Home: Micro Single Vertical Contact

## 22-26 AWG: WTB



70-9296

70-9296-001-112-006

### 9296 VERTICAL MOUNT SMT CONTACT THROUGH BOARD CONTACT – TOP ENTRY WIRE (FR4 BOARD)

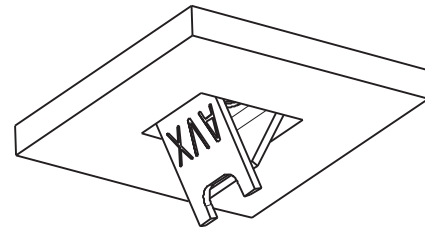
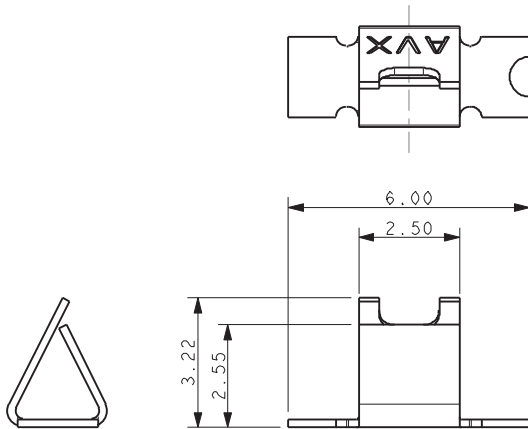

THROUGH BOARD CONTACT

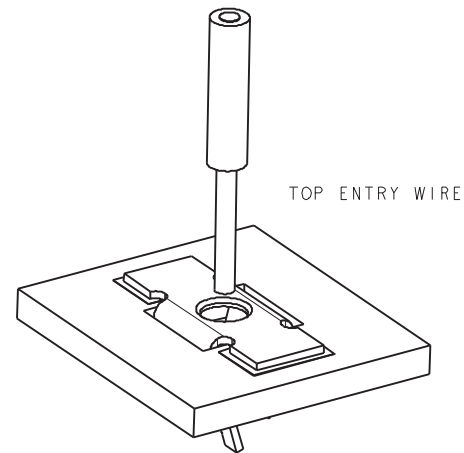
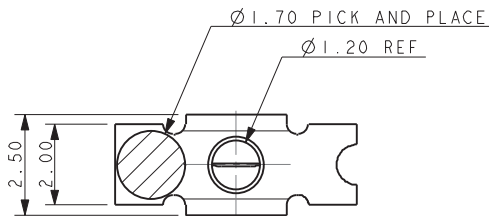

TOP ENTRY WIRE

### SUGGESTED PCB LAYOUT

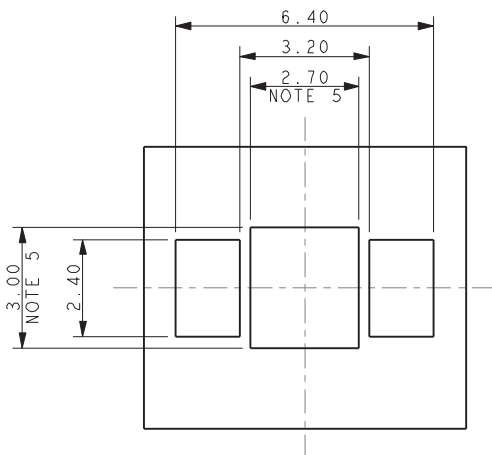

#### NOTES:

- CONTACT MOUNTS THROUGH THE BOARD, WIRE INSERTED FROM TOP SIDE OF BOARD.
- STYLE RECOMMENDED FOR FR4 BOARDS WHERE ADDITIONAL CLEARANCE REQUIRED TO CONTACT AND MOUNTING PADS.
- FOR FURTHER INFORMATION REFER TO ELCO SPECIFICATION 201-01-161 AND APPLICATION NOTES 201-01-175.
- MATERIAL: TIN PLATED PHOSPHOR BRONZE.
- HOLE DIMENSIONS FOR CONTACT.
- PACKING IN TAPE AND REEL, 2000 PIECES PER REEL.
- FOR WIRE TRIM DETAILS REFER TO PAGE 113.
- WIRE SIZES REFER TO PAGE 108.
- GENERAL TOLERANCE  $\pm 0.10$ .
- UL REFERENCE E90723 (US AND CANADA).

### PACKING DETAILS

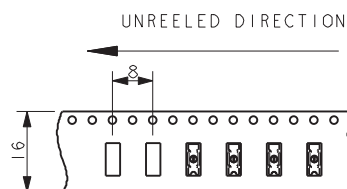

QUANTITY 2000 PER REEL

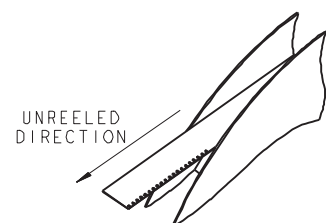

330mm DIAMETER REEL

# Poke-Home: Micro Single Vertical Contact

## 22-26 AWG: WTB



70-9296

70-9296-001-122-006

### 9296 VERTICAL MOUNT SMT CONTACT

#### TOP SIDE CONTACT – BOTTOM ENTRY WIRE (METAL BOARD)

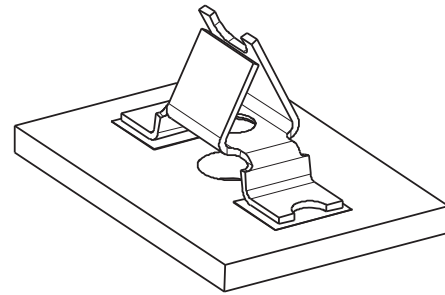
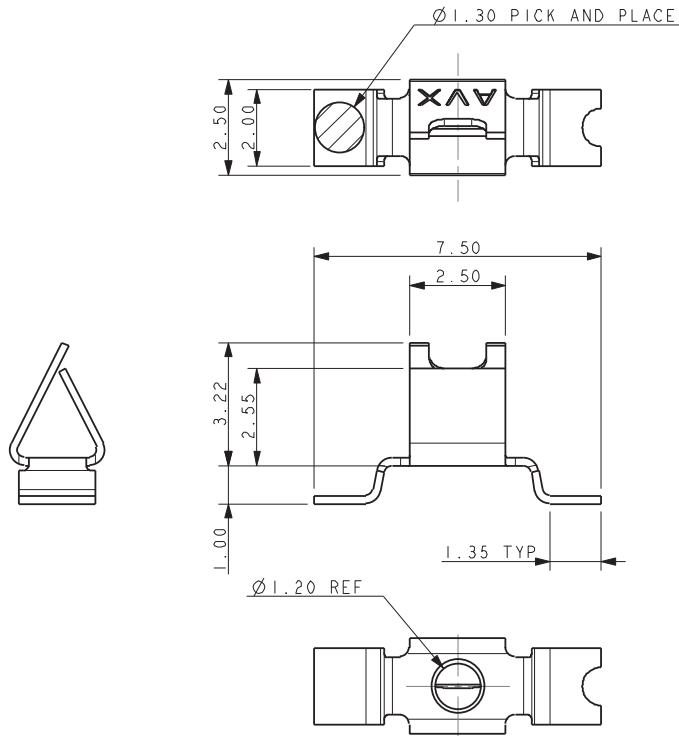

TOP SIDE CONTACT

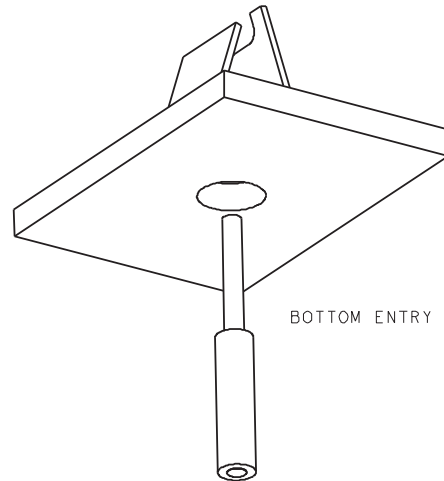

BOTTOM ENTRY WIRE

### SUGGESTED PCB LAYOUT

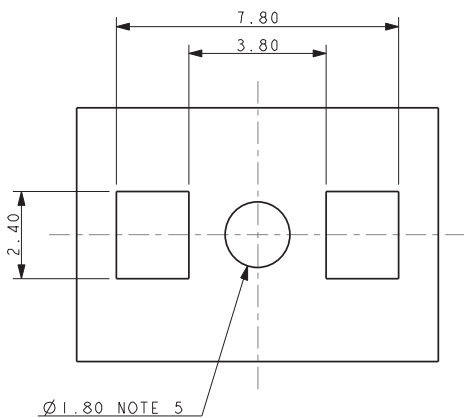

#### NOTES:

1. CONTACT MOUNTS ON TOP SIDE OF BOARD, WIRE INSERTED FROM UNDERSIDE OF BOARD.
2. STYLE RECOMMENDED FOR METAL CLAD BOARDS WHERE ADDITIONAL CLEARANCE REQUIRED TO CONTACTS AND MOUNTING PADS.
3. FOR FURTHER INFORMATION REFER TO ELCO SPECIFICATION 201-01-161 AND APPLICATION NOTES 201-01-150.
4. MATERIAL: TIN PLATED PHOSPHOR BRONZE.
5. HOLE FOR WIRE INSERTION.
6. PACKING IN TAPE AND REEL, 1600 PIECES PER REEL.
7. FOR WIRE TRIM DETAILS REFER TO PAGE 113.
8. WIRE SIZES REFER TO PAGE 108.
9. GENERAL TOLERANCE  $\pm 0.10$ .
10. UL REFERENCE E90723 (US AND CANADA).

### PACKING DETAILS

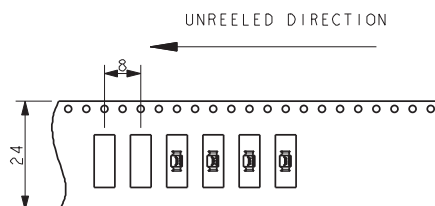

QUANTITY 1600 PER REEL

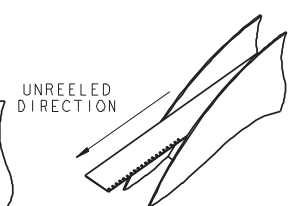

330mm DIAMETER REEL

# Poke-Home: Micro Single Vertical Contact

## 22-26 AWG: WTB



70-9296

70-9296-001-132-006

### 9296 VERTICAL MOUNT SMT CONTACT THROUGH BOARD CONTACT – TOP ENTRY WIRE (METAL BOARD)

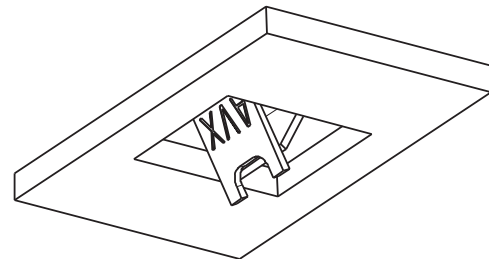
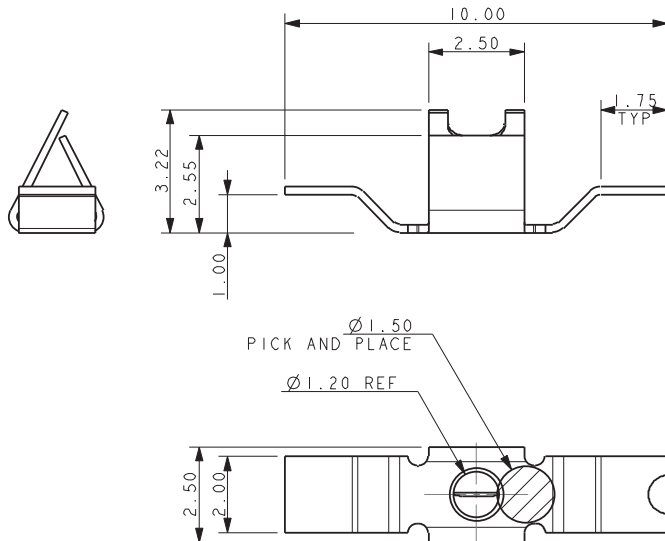

THROUGH BOARD CONTACT

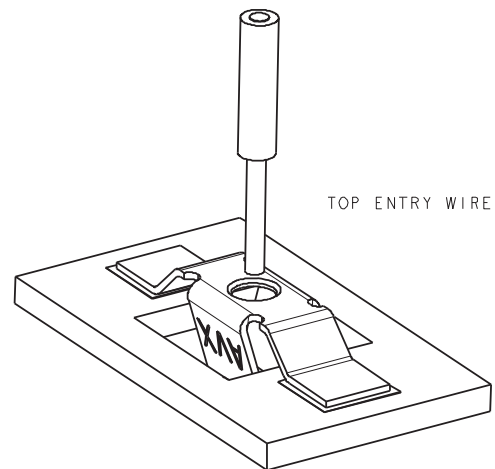

TOP ENTRY WIRE

### SUGGESTED PCB LAYOUT

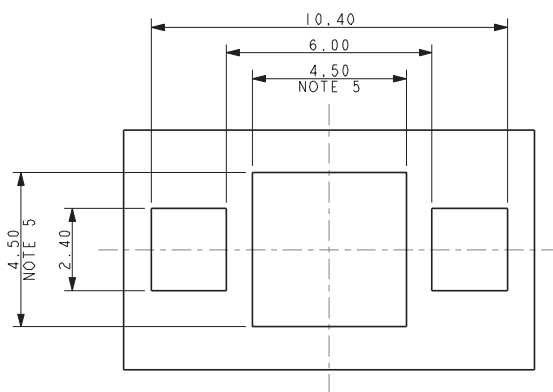

#### NOTES:

- CONTACT MOUNTS ON TOP SIDE OF BOARD, WIRE INSERTED FROM UNDERSIDE OF BOARD.
- STYLE RECOMMENDED FOR METAL CLAD BOARDS WHERE ADDITIONAL CLEARANCE REQUIRED TO CONTACTS AND MOUNTING PADS.
- FOR FURTHER INFORMATION REFER TO ELCO SPECIFICATION 201-01-161 AND APPLICATION NOTES 201-01-175.
- MATERIAL: TIN PLATED PHOSPHOR BRONZE.
- HOLE FOR WIRE INSERTION.
- PACKING IN TAPE AND REEL, 2000 PIECES PER REEL.
- FOR WIRE TRIM DETAILS REFER TO PAGE 113.
- WIRE SIZES REFER TO PAGE 108.
- GENERAL TOLERANCE  $\pm 0.10$ .
- UL REFERENCE E90723 (US AND CANADA).

### PACKING DETAILS

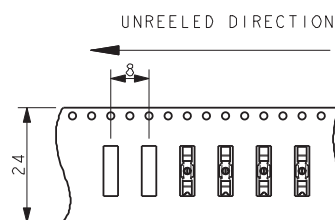

QUANTITY 2000 PER REEL

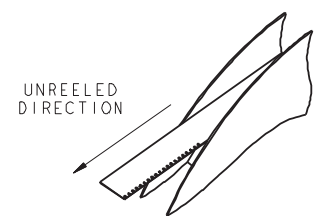

330mm DIAMETER REEL

70-9296

### 9296 VERTICAL MOUNT SMT CONTACT WIRE TRIM DETAILS

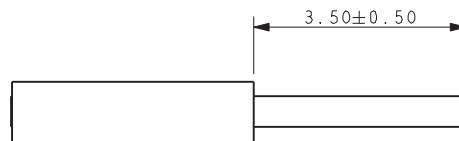

WIRE STRIP LENGTH, ALL STYLES

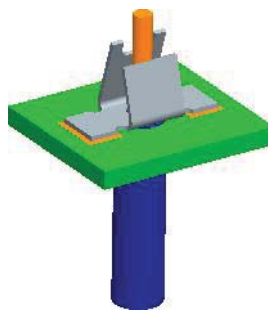

70-9296-001-103-006

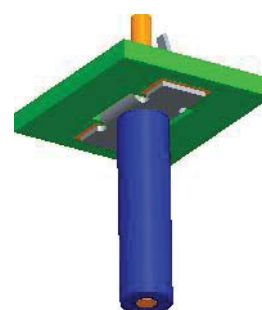

70-9296-001-113-006

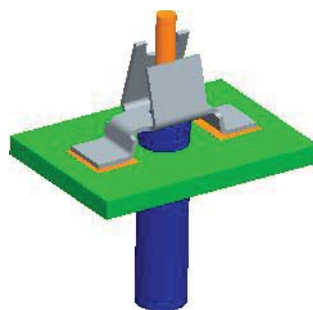

70-9296-001-123-006

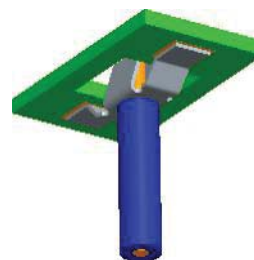

70-9296-001-133-006

NOTES:

1. FOR FULL ASSEMBLY PROCEDURE REFER TO APPLICATION NOTES 201-01-175.
2. THE SAME WIRE STRIP LENGTH APPLIES TO ALL STYLES.
3. STRANDED WIRES SHOULD BE TWISTED TO PREVENT SINGLE STRANDS BECOMING DETACHED WHEN INSERTED INTO CONTACT.
4. SUITABLE FOR SOLID AND STRANDED WIRES 22AWG, 24AWG AND 26AWG. STRANDED WIRES 26AWG MAY REQUIRE TINNING TO AID INSERTION.