

AOYUE[®]

INT 866

(Centigrade / Fahrenheit switchable)

Complete Repairing System

INSTRUCTION MANUAL

Thank you for purchasing Aoyue Int866 Complete Repairing system.
It is important to read the manual before using the equipment.
Please keep manual in accessible place for future reference.



This manual is designed to familiarize and instruct the operator with the proper usage and maintenance of the equipment. The “Care and Safety Precautions” section explains the hazards of using any type of soldering or re-working device. Please read carefully and observe the guidelines in order to maximize usage and minimize the risk of injury or accidents .

TABLE OF CONTENTS

Product Description 3

Specifications 3

Package Inclusion 4

Functions and Features 5

Safety Precautions 6

Assembly and Preparation 7

Control Panel Guide 8

Operating Guidelines 9—12

Auto-Sleep Functions 13—14

Digital Calibration 15—16

Care and Maintenance 17

Basic Troubleshooting Guide 18

Replacement Tips 19

Air Nozzles 20

Manufacturer:
AOYUE INTERNATIONAL LIMITED
Jishui Industrial Zone, Nantou, Zhongshan City,
Guangdong Province, P.R.China
<http://www.aoyue.co>

PRODUCT DESCRIPTION

The Aoyue INT866 Complete Repairing System is a reworking equipment that combines the functionality of Hot Air Gun, Soldering Iron, Hot Air Gun stand, Temperature Meter and Pre-heating in one package.

It has several safety features such as the auto-cooling process of the Hot Air Gun. This functionality protects the device (and its components) from excessive heat upon reaching any of the following conditions: (1) when the soldering gun remained idle after a certain period and (2) when the temperature of the device is above a safe threshold upon turning off. It has several advanced features such as solder iron digital calibration, configurable auto sleep for hot-air and soldering iron and switchable centigrade or Fahrenheit readout.

SPECIFICATION

MAIN STATION	
Power Input :	available in 110V / 220V
Station Dimensions:	192(w) x 100(h) x 325(d) mm
Weight:	6.58 Kg
SOLDERING IRON	
Power Consumption:	75W
Temperature Range:	200°C - 480°C / 392°F - 896°F
Heating Element:	Ceramic Heater
Output Voltage:	24V
HOT AIR GUN	
Power Consumption:	500W
Temperature Range:	100°C - 480°C / 212°F - 896°F
Heating Element	Metal Heating Core
Pump/Motor Type:	Siroccoo Fan
PRE-HEATER	
Power Consumption:	500W
Temperature Range:	100°C - 480°C / 212°F - 896°F
Heating Element	Quartz Crystal

Specifications are subject to change without prior notice.

PACCKAGE I INCLUSIONS

1 unit Int866 Main Station with Pre-heater and Hot Air Gun

1 pc. Spare Hot Air Gun Heating Element

1 pc. External Sensor

1 pc. Hot Air Gun Mast with Wire Holder

1 pc. 3-Segment Fully Articulating Arm Holder

1 pc. Holder Stopper with Securing Screw

6 pcs. PCB Holder

7 pcs. PCB Holder Securing Screw

1 pack AT-9 Air Nozzle Set (T1194, T1195, T1198, BGA-S)

1 pc. B016 Soldering Iron with Tip

1 pc. Spare Soldering Iron Heating Element

1 pack Soldering Iron Tips (10pcs) includes T-0.5C, T-0.8C, T-0.8D, T-1C, T-1.2D, T-1.6D, T-2.4D, T-B, T-LB, T-I*

1 pc. 2663 Soldering Iron Stand**

1 pc. Soldering Iron Stand Assembly guide

1 set Vacuum Pen with 3 vacuum caps

1 pc. Tool Box

1 pc. G001 IC Popper

1 pc. Instruction Manual

1 pc. Power Cord

* Type of soldering tip included might change depending on availability. T-I already installed on Soldering Iron.

** Kindly refer to soldering iron stand installation on page 5 for parts and instructions.

FUNCTION and FEATURES

- Microprocessor-controlled ESD safe equipment.
- 4-in-1 repairing system combining Hot Air Gun, Soldering Iron, Pre-Heater, External Sensor, Hot Air gun stand in one sophisticated package.
- Digital control and display of hot air temperature, soldering iron temperature, air pressure, pre-heater temperature with touch panel controls for precision and ease of use.
- Switchable temperature readout between Fahrenheit and centigrade.
- Integrated hot air gun platform.
- User configurable 1 to 30 minute idle-to-auto-stand-by mode (with 30 minutes as default) for additional device protection and power saving.
- Built-in auto-cooling process that protects the system and its components from excessive heat, prolonging usage life.
- Built-in auto-sleep mode for soldering iron.
- Compatibility with air nozzles of various types.
- Compatibility with different kind of soldering tips.

ASSEMBLY and PREPARATIONS

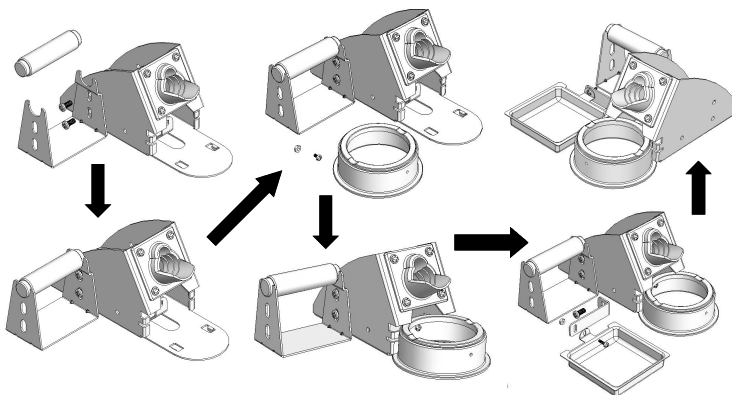

SAFETY PRECAUTIONS



CAUTION: Improper usage can cause serious injury to personnel and/or damage to equipment. For your own safety, please observe the ff. precautions.

- Check each component after opening the package to make sure everything is in good condition. If there are any suspected damage, do not use the item and report the issue to your vendor.
- Turn OFF the main power switch and unplug the device when moving the device from one location to another.
- Do not strike or subject the main unit to physical shock. Use carefully to avoid injury and damage to any part.
- Handle with care.
 - Never drop or sharply jolt the unit.
 - Contains delicate parts that may break if the unit is dropped.
- Make sure the equipment is always grounded. Always connect power to a grounded receptacle.
- Temperature may reach as high as 480°C when switched ON.
 - Do not use the device near flammable gases, paper and other flammable materials.
 - Do not touch heated parts, which can cause severe burns.
 - Do not touch metallic parts near the tip.
- Disconnect the plug from the power source if the unit will not be used for a long period.
 - Turn off power during breaks, if possible.
- Use only genuine replacement parts.
 - Turn off power and let the unit cool before replacing parts.
- The unit may produce a small amount of smoke and unusual odor during initial usage. This is normal and should not yield any negative result when reworking.
- Soldering process produces smoke — use on well ventilated place.
- Do not alter the unit, specifically the internal circuitry, in any manner.

ASSEMBLY and PREPARATIONS

A. Main Station and Hot Air Gun Stand

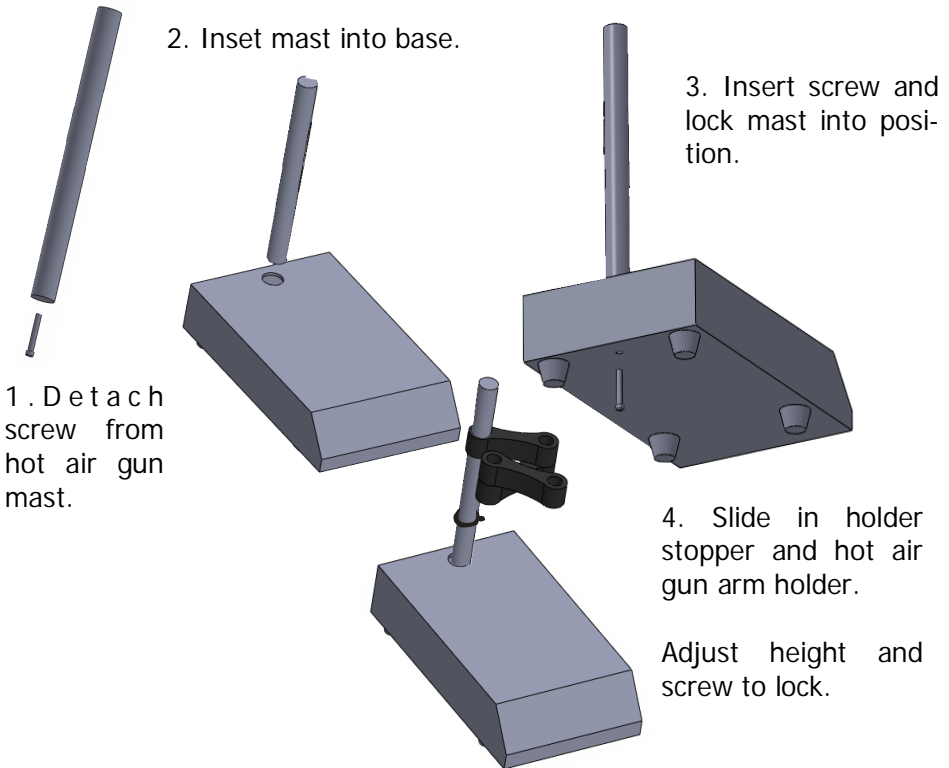

B. Soldering Iron

1. Follow instructions on "Soldering Iron Stand Assembly " on page 5.
2. Connect the soldering iron cord assembly to the soldering iron output terminal found at the lower middle portion of the main unit.
3. Place the soldering iron to the soldering iron stand.

C. Pre-heater

1. Screw in PCB Holder using Securing Screw on desired position.
2. Adjust multipurpose PCB holder to accommodate PCB shape.

D. Hot Air Gun

To set up the Hot Air Gun stand:

1. Use the 8 mm screw to secure the holder to the station.
2. Place the hot air gun onto the stand in preparation for usage.

CONTROL PANEL GUIDE

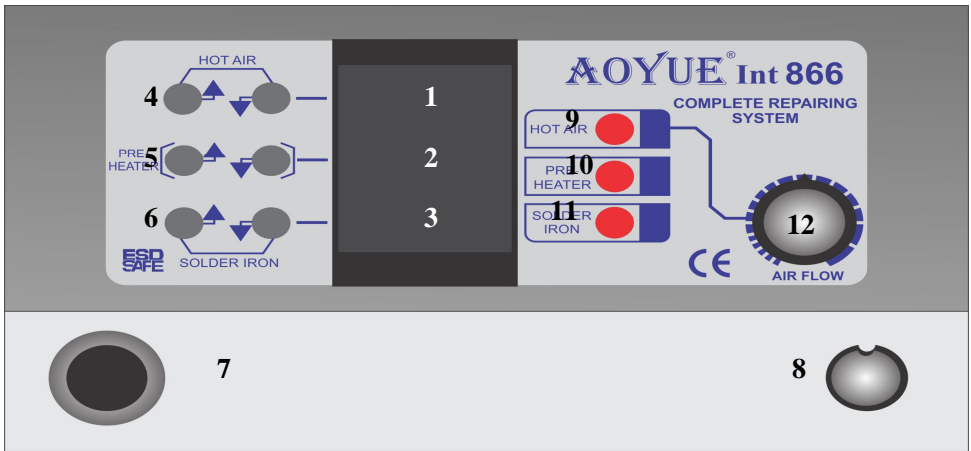

LEGEND:

- 1 — Hot Air Gun Temperature Display
- 2 — Pre-Heater Temperature Display
- 3 — Soldering Iron Temperature Display
- 4 — Hot Air Gun Temperature Adjustment Buttons
- 5 — Pre-Heater Temperature Adjustment Buttons
- 6 — Soldering Iron Temperature Adjustment Buttons
/ External sensor activation
- 7 — Hot Air Gun Output Terminal
- 8 — Soldering Iron Receptacle, External Sensor Probe Receptacle
- 9 — Hot Air Gun Function Activation Switch
- 10 — Pre-Heater Function Activation Switch
- 11 — Soldering Iron Function Activation Switch
- 12 — Hot Air Gun Airflow Adjustment

Prefixes and meanings:

- "A" - External Sensor
- "H" - actual temperature
- "h" - temperature being set
- "C" - cooling down
- "---" - sleep mode display
- "OFF" - function deactivated display

OPERATING GUIDELINES

IMPORTANT REMINDERS:

1. Make sure the equipment is placed on a flat stable surface and all the heat-generating components placed on their respective holders or stands.
2. Ensure all function switches are OFF prior to reworking.
3. Ensure all terminal connections are properly secured.

IMPORTANT: Please refer to the **CONTROL PANEL GUIDE** page for buttons and display panel directory.

A. INITIAL PROCEDURES

1. Plug the device to the main power source using the power cord provided in the package.
2. With all function switches deactivated and all terminal connections properly secured, switch ON the device by activating the main power switch located at the back of the unit.
3. The display panels, will temporarily show the product name in a scrolling manner and then display "OFF" on all rows once the scroll is finished (see below illustration). The system will remain at this state until the user activates a function.

B. CELCIUS TO FAHRENHEIT SWITCHING

1. Plug the device to the main power source using the power cord provided in the package.
2. Press and hold the solder iron UP button while turning on the system power to set system to Centigrade mode. The display will show "Aoyue 866C" with the last character indicating the type of temperature scale used. "C" Centigrade, "F" Fahrenheit.
3. Press and hold the solder iron DOWN button while turning on the system power to set system to Fahrenheit mode. The display will show "Aoyue 866F" with the last character Indicating the type of temperature scale used. "C" Centigrade, "F" Fahrenheit.

OPERATING GUIDELINES

C. HOT AIR GUN

1. Follow the initial procedures above, "**A. INITIAL PROCEDURES**".
2. Adjust Hot Air Gun Airflow Adjustment to the middle position.
3. Activate "Hot Air Gun" switch ("9" from the control panel).
4. The system will immediately start to blow air at a medium airflow while rapidly and safely increasing the air temperature to **100°C** (default system operating parameters). These values will be reflected from the Hot Air Gun Air Temperature display panels, "1" from the control panel, respectively.
5. Adjust to desired air flow.
6. Adjust the hot air gun temperature using the HOT AIR GUN TEMPERATURE ADJUSTMENT BUTTONS ("4" from the control panel). The prefix of the display for Hot Air Gun Temperature will change from "H" to "h" indicating that air temperature is being adjusted. It will return to "H" (indicating actual temperature) while the temperature is gradually increasing or decreasing until the desired temperature is reached.

 **IMPORTANT: When adjusting the air temperature, it is strongly advised to initially increase the airflow level in order to manage the system temperature. This is to protect the heating element inside the handle from excessive heat and avoid the possibility of subjecting adjacent components to thermal shock.**

7. Reworking task can be started 1 minute after the desired hot air temperature and airflow level are reached, as also indicated from display panel "1".
8. When reworking is complete, return the Hot Air Gun to its holder and **DO NOT** immediately turn off the main power switch.

OPERATING GUIDELINES

9. Deactivate the Hot Air Gun Activation button first in order to activate the auto-cooling process. The system will start to blow air (at room temperature) at a fast rate to reduce heat from the hot air gun and bring down the temperature to a reasonable safe level of **90°C**. During this time, the prefix of the display for hot air gun temperature will also change from "H" to "C" while temperature is gradually decreasing. Likewise, the air pressure level is at its highest reading as indicated from the display panel. Once the temperature drops to approximately **90°C** the system will halt and display "OFF" on the panel. It is now safe to switch off the main power switch.
10. Turn OFF the main power switch.
11. Unplug the device from the main power source.

D. SOLDERING IRON

1. Connect the Soldering Iron connection assembly to the 6-pin receptacle located at the front of the control panel ("8" from the CONTROL PANEL GUIDE).
2. Follow the initial procedures ("**A. INITIAL PROCEDURES**").
3. Activate the "SOLDER IRON" Activation switch ("11" from control panel). This will automatically start to increase the temperature of the soldering iron to **350°C** (default).
4. Adjust the soldering iron temperature using the SOLDERING IRON ADJUSTMENT buttons ("6" from the control panel).
5. Start using the soldering iron as soon as desired temperature is reached.
6. Deactivate the SOLDER IRON activation switch.
7. Allow sufficient time for the soldering iron to cool down before keeping in a safe storage.

OPERATING GUIDELINES

E. PRE-HEATER

1. Follow the initial procedures ("**A. INITIAL PROCEDURES**").
2. Place PCB to be pre-heated on top of the pre-heater.
3. Activate the Pre-Heater Activation switch ("10" from control panel). This will automatically start to increase the temperature of the soldering iron to **100°C** (default).
4. Adjust the Pre-heating temperature using the PREHEATING TEMPERATURE ADJUSTMENT buttons ("5" from the control panel).
5. The top heater may be activated for reworking multilayered boards once the PCB has been pre-heated to desired temperature.
6. The actual board temperature may be determined by placing the external sensor on the target board.
7. After reworking deactivate the PREHEATING activation switch.

F. EXTERNAL SENSOR

1. Follow the initial procedures ("**A. INITIAL PROCEDURES**").
2. Place PCB to be pre-heated or reworked on top of the pre-heater.
3. Attach the external sensor probe to the external sensor probe receptacle. ("8" from the control panel).
4. With the soldering iron function switch deactivated press the down button of the solder iron temperature adjustment button to activate the external sensor function.
5. The actual board temperature may be determined by placing the external sensor on the target board.
6. To turn off external sensor probe function press the solder iron up switch.

AUTO SLEEP FUNCTIONS

AUTO-SLEEP MODE (Hot Air Gun)

The device has a built-in auto-sleep mode feature such that if there has been no user input from the hot air gun temperature adjustment button for 30 minutes (default) the Hot Air Gun remained, the device will switch to sleep mode. The system will blow air (at room temperature) at maximum rate in order to bring down the temperature. Once the temperature drops to approximately 90°C, the Hot Air Gun will automatically stop and show an all-dash " - - - - " display indicating that the system is now on sleep mode.

CHANGING SLEEP MODE TIMER (HOT AIR GUN)

By default, the system has 30-minute countdown time before the hot air gun goes to sleep mode. This can be altered by the following procedure.

1. While the hot air gun is on stand-by mode ("OFF" is displayed on the panel "1"), hold both **UP** and **DOWN** buttons of the HOT AIR GUN TEMPERATURE adjustment buttons.
2. Wait until "t030" is displayed on the Hot Air Gun Temperature display panel, "1".
3. Release the buttons when "t030" appears.
4. Adjust the time using the same **UP** and **DOWN** buttons of the HOT AIR GUN TEMPERATURE adjustment buttons.
5. Confirm the change by activating the HOT AIR GUN function switch.
6. The system will immediately switch back to operation and use the defined countdown parameter for the entire usage.

NOTES:

- The sleep mode timer is configurable between **1** and **30** minutes. Sleep mode settings for Hot-Air gun and Soldering Iron are saved into the memory and shall remain effective until it is reset or new data is entered.

AUTO SLEEP FUNCTIONS

SOLDERING IRON AUTO-SLEEP MODE

The soldering iron's SLEEP mode is deactivated by default. Follow the set of procedures below to activate this feature.

CONDITION: SOLDERING IRON function is inactive.

1. While soldering iron is displaying "**OFF**" or in stand-by mode, push both UP and DOWN buttons of the SOLDERING IRON TEMPERATURE adjustment buttons ("6" from the CONTROL PANEL GUIDE page).
2. Wait until "**tOFF**" appears from soldering iron temperature display panel. This means sleep mode is currently turned OFF.
3. Release the two buttons after the change in display.
4. Use the same two buttons to adjust the countdown time. "**t001**" means solder iron will go to sleep in 1 minute. Timer is adjustable from 1 to 60minutes.
5. Confirm the change by activating the SOLDERING IRON switch.
6. To **DEACTIVATE** this feature, simply follow the above procedures. This time, select "**tOFF**".
7. During sleep mode, the soldering iron temperature display panel will show an all-dash, "- - - -".
8. To wake the soldering iron from sleep mode, press the soldering iron temperature adjustment buttons.

DIGITAL CALIBRATION

SOLDER IRON DIGITAL TEMP CALIBRATION

By default, the system is properly calibrated but for cases when a little adjustment of the soldering iron calibration is required the following procedure can be done.

1. Turn on the soldering iron function switch.
2. Set to appropriate temperature you want to calibrate. Place the tip of the soldering iron on an external temperature sensor.
3. The readings on the external temperature sensor should be more or less equal to the displayed temperature.
4. If there are large discrepancy in the temperature reading we can re-calibrate the temperature setting.
5. While the solder iron is operating make sure the hot air gun and Preheating function is in off mode ("**OFF**" is displayed on the panels "1" and "2"), hold the preheater **UP** button for a few seconds until four zeroes are displayed "0000" .
6. Adjust the temperature compensation using the **UP** and **DOWN** buttons of the Soldering iron adjustment buttons.
7. A zero "0" on the first digit signifies addition to the current temperature and a minus "-" on the first digit will subtract the displayed value from the current settings.
8. Confirm the change by pressing the air pressure down button.

DIGITAL CALIBRATION

Solder Iron Digital Temperature Calibration Example

- The external temperature sensor displays 248 to 252 degrees.
- The set temperature and displayed actual temperature of the soldering iron is 300 degrees.
- $300 - 248 = 52$. An additional adjustment of 52 degrees is required.
- Enter calibration mode
- We increase from "0000" to "0052".
- Exit calibration mode.
- The external temperature sensor would now display 298 to 302 degrees.

NOTES:

- The calibrated data is saved into the memory and shall remain effective until it is recalibrated again or new data is entered.
- Calibration will only make the newly calibrated point the most accurate. Other temperature points may be a little off.
- The soldering Iron has a lowest temperature limit such that when the temperature has been set to 200 degrees with external actual temperature also showing 200 degrees, further decreasing the temperature offset would be only have minimal effect to the actual temperature.

CARE and MAINTENANCE

Soldering Iron Tip

Always keep the solder-plated section of the tip/nozzle coated with a small amount of solder. Oxide coating on the tip of the nozzle reduces its heat conductivity. Coating the tip with a small amount of fresh solder ensures maximum heat conductivity is obtained.

CARE and MAINTENANCE

Soldering Iron Error Messages

1. Soldering Iron connection assembly is not connected or not properly connected to the receptacle on the control panel.
2. Soldering iron tip is damaged and needs to be replaced. The device will display "PLUG".
3. Indicating a problem with the contacts of the soldering iron or the tip.

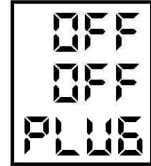

This appliance can be used by children aged from 8 years and above and persons with reduced physical, sensory or mental capabilities or lack of experience and knowledge if they have been given supervision or instruction concerning use of the appliance in a safe way and understand the hazards involved. Children shall not play with the appliance. Cleaning and user maintenance shall not be made by children without supervision.

The specific instructions related to the safe operation of this appliance (as given in 7.12 of this standard) shall be collated together in the front section of the user instructions. The height of the characters, measured on the capital letters, shall be at least 3 mm. These instructions shall also be available in an alternative format, e.g. on a website.

A fire may result if the appliance is not used with care, therefore:

- be careful when using the appliance in places where there are combustible materials ;
- do not apply to the same place for a long time;
- do not use in presence of an explosive atmosphere;
- be aware that heat may be conducted to combustible materials that are out of sight;
- place the appliance on its stand after use and allow it to cool down before storage;
- do not leave the appliance unattended when it is switched on.

Rohs

Correct Disposal of this product	
	This marking indicates that this product should not be disposed with other household wastes throughout the EU. To prevent possible harm to the environment or human health from uncontrolled waste disposal, recycle it responsibly to promote the sustainable reuse of material resources. To return your used device, please use the return and collection systems or contact the retailer where the product was purchased. They can take this product for environmental safe recycling.

BASIC TROUBLESHOOTING GUIDE

PROBLEM 1: THE UNIT HAS NO POWER

1. Check if the unit is switched ON.
2. Check the fuse. Replace with the same type if fuse is blown.
3. Check the power cord and make sure there are no disconnections.
4. Verify that the unit is properly connected to the power source.

PROBLEM 2: HOT-AIR GUN TEMPERATURE DISPLAY IS ALWAYS ABOVE 500°C

Description: Constant display of above 500°C temperature from the panel then displays an “Err1” on the panel after a few minutes.

SOLUTION:

The thermal sensor may be broken and needs to be replaced.

PROBLEM 3: HOT-AIR GUN ACTUAL AIR TEMPERATURE IS NOT INCREASING

Description: Actual temperature reading is not increasing or decreasing based on desired level.

SOLUTION:

The heating element may be broken or is at the end of its life and needs to be replaced.

PROBLEM 4: SOLDERING IRON TEMPERATURE DISPLAY PANEL SHOWS “PLUG” CHARACTERS

Case 1: The system shows “PLUG” from the soldering iron temperature display panel .

SOLUTION : Check if the soldering iron connection assembly is properly connected and secured to the receptacle on the control panel.

PROBLEM 5: UNIT SHOWS UNCONVENTIONAL BEHAVIOR

Description: Unit operates erratically.

SOLUTION1: Try to switch OFF the device and switch ON again. Unplug the system from the main power source and plug in again when necessary

SOLUTION2: Restore unit to default factory setting. switch off/on the unit while holding the hot-air temperature down button until the banner finishes scrolling, the unit would revert to its default factory setting.

OTHER PROBLEMS NOT MENTIONED:

Contact the vendor.

MOYUE®

Replacement Air Nozzles

BGA SERIES

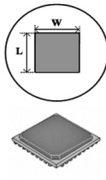
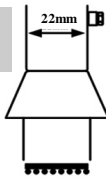

SOP SERIES

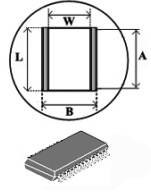
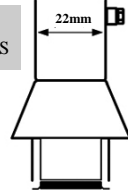

SGL SERIES

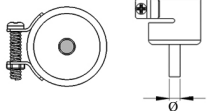

MODEL #	NOZZLE SIZE Ø
1124	2.4mm
1130	4.4mm
1194	6mm
1195	8mm
1196	7mm
1197	9mm
1198	12mm

MODEL #	IC SIZE	L(mm)	W(mm)
1010	9 × 9mm	10	10
1313	12 × 12mm	13	13
1616	15 × 15mm	16	16
1919	18 × 18mm	19	19
2828N	27 × 27mm	28	28
3030N	29 × 29mm	30	30
3232W	31 × 31mm	32	32
3636W	36 × 36mm	36	36
3939W	38 × 38mm	39	39
4141W	40 × 40mm	41	41
4343W	42 × 42mm	43	43
4545W	44 × 44mm	45	45

MODEL #	IC SIZE	L(mm)	W(mm)	A(mm)	B(mm)
1131	4.4 × 10mm	11	3.8	9	10.3
1132	5.6 × 13mm	16	4.7	14	11.7
1133	7.5 × 15mm	17	6	15	13
1134	7.5 × 18mm	20	6	18	13
1257	11 × 21mm	22	11	20	18
1258	7.6 × 12.7mm	12	7	10	14
1259	13 × 28mm	30	12.5	28	19.5
1260	8.6 × 18mm	20	7.7	18	14.7

QFP SERIES

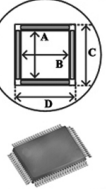
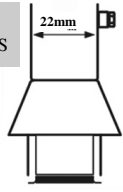

SOJ SERIES

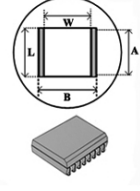
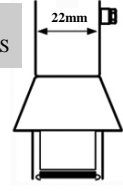

MODEL #	IC SIZE	A(mm)	B(mm)	C(mm)	D(mm)
1125	10 × 10mm	9	9	16	16
1126	14 × 14mm	14	14	21	21
1127	17.5 × 17.5mm	18	18	25	25
1128	14 × 20mm	20	14	21	27
1129	28 × 28mm	28	28	35	35
1215	42.5 × 42.5mm	41	41	48	48
1261	20 × 20mm	19	19	26	26
1262	12 × 12mm	11	11	18	18
1263	28 × 40mm	38	28	35	45
1264	40 × 40mm	39	39	46	46
1265	32 × 32mm	31	31	38	38

MODEL #	IC SIZE	L(mm)	W(mm)	A(mm)	B(mm)
1183	15 × 8mm	17	7	15	14
1184	18 × 8mm	20	9	18	16
1214	10 × 26mm	27	11	25	18

TSOL SERIES

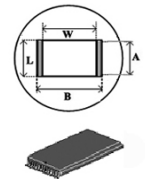
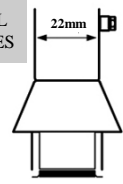

PLCC SERIES

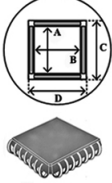
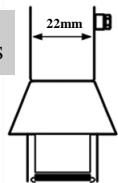

MODEL #	IC SIZE	L(mm)	W(mm)	A(mm)	B(mm)
1185	13 × 10mm	11	11	9	18
1186	18 × 10mm	12	17	10	24
1187	18.5 × 8mm	11	18	9	25

SIL SERIES

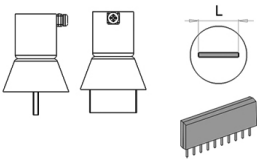

MODEL #	IC SIZE	A(mm)	B(mm)	C(mm)	D(mm)
1135	17.5 × 17.5mm	17.5	17.5	24.5	24.5
1136	20 × 20mm	20	20	27	27
1137	25 × 25mm	25	25	32	32
1138	30 × 30mm	30	30	37	37
1139	7.3 × 12.5mm	7.5	12.5	14.5	19.5
1140	11.5 × 11.5mm	12	12	19	19
1141	11.5 × 14mm	12	14	19	21
1188	9 × 9mm	10	10	17	17
1189	34 × 34mm	35.5	35.5	42.5	42.5

BQFP SE-

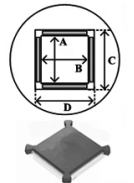
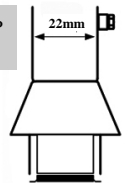

MODEL #	IC SIZE	L(mm)	W(mm)	A(mm)	B(mm)
1180	17 × 17mm	17.2	17.2	24.2	24.2
1181	19 × 19mm	18.2	18.2	25.2	25.2
1182	24 × 24mm	23.2	23.2	30.2	30.2
1203	35 × 35mm	34.2	34.2	41.2	41.2

MODEL #	IC SIZE	L(mm)
1191	SIP25L	26
1192	SIP50L	52.5