

R325PE Single Axis Driver with Indexer and Encoder Reader

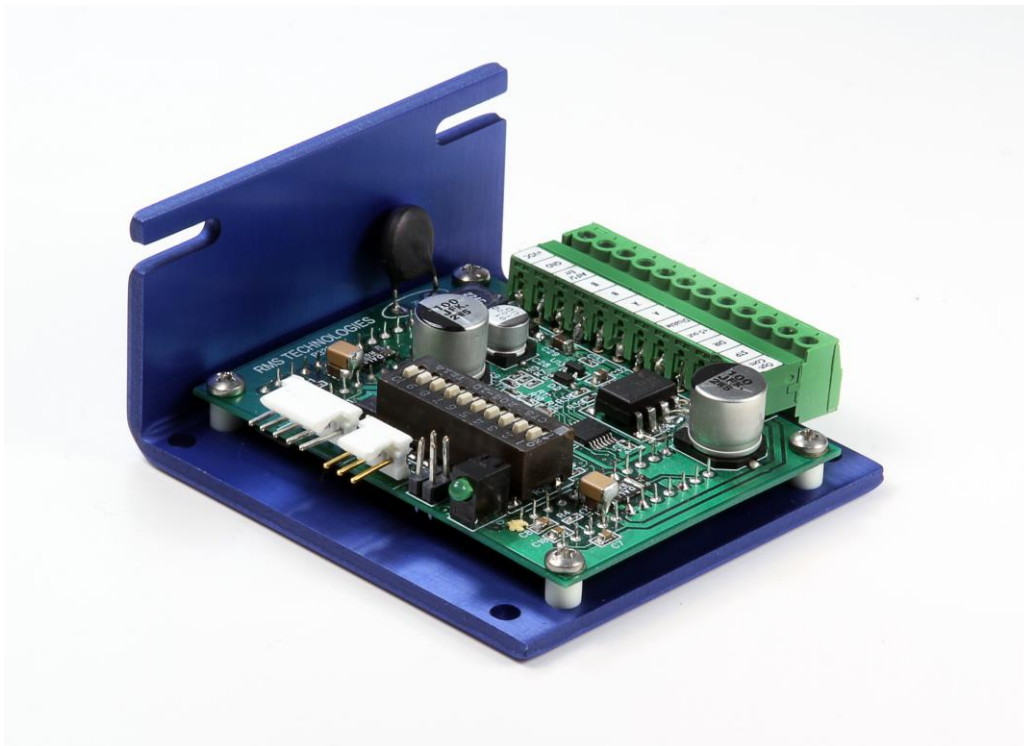

**User Manual
And Commands Guide**

Version 3.1

Lin Engineering
16245 Vineyard Blvd, Morgan Hill, CA 95037

Thank you for purchasing the R325PE Single-Axis Driver with Indexer. This product is warranted to be free of manufacturing defects for one (1) year from the date of purchase.

PLEASE READ BEFORE USING

Before you start, you must have a suitable step motor, a DC power supply suitable for the motor and a current resistor. The power supply voltage must be between 4 times and 20 times the motor's rated voltage.

DISCLAIMER

The information provided in this document is believed to be reliable. However, no responsibility is assumed for any possible inaccuracies or omissions. Specifications are subject to change without notice.

Lin Engineering reserves the right to make changes without further notice to any products herein to improve reliability, function, or design. Lin Engineering does not assume any liability arising out of the application or use of any product or circuit described herein; neither does it convey any license under its patent rights, nor the rights of others.

Special Symbols



Indicates a WARNING and that this information could prevent injury, loss of property, or even death (in extreme cases).

R325PE User Manual

Product: R325PE
Version: 3.1
Date: 3/19/2018

Version History		
Version	Date	Description of Changes
1.00	01/31/2013	New User Manual
2.00	05/29/2013	Updated enable/disable pin description on page 8.
3.00	9/29/2014	Updated default Baud rate to 57600 (typo)
3.1	3/19/2018	Updated Name/Logo

Table of Contents

<u>1. FEATURES.....</u>	<u>5</u>
<u>2. ELECTRICAL SPECIFICATIONS.....</u>	<u>5</u>
<u>3. OPERATING SPECIFICATIONS</u>	<u>6</u>
<u>4. MECHANICAL SPECIFICATIONS</u>	<u>6</u>
<u>6. CONNECTION SPECIFICATIONS</u>	<u>8</u>
Connecting the Power	9
Connecting the Motor	9
Configure the R325 using the DIP Switch	11
DIP Switch Run Current Settings.....	11
DIP Switch Hold Current Settings	11
DIP Switch Step Resolution Settings.....	11
<u>8. COMMAND TABLES.....</u>	<u>13</u>
Basic Configuration Commands.....	13
Axis Configuration Commands	13
General Operation Commands	14
General Operation Commands	14
<u>10. COMMANDS</u>	<u>15</u>
HOMING & POSITIONING	16
VELOCITY & ACCELERATION	16
SETTING CURRENT	19
STORAGE & RECALL	19
MICROSTEPPING	20
QUERY COMMANDS	21
ENCODER VERSION COMMANDS	22
<u>10. Troubleshooting.....</u>	<u>24</u>
<u>11. Appendix A.....</u>	<u>25</u>
<u>11. Appendix B.....</u>	<u>29</u>

1. FEATURES

- Single Axis Driver with indexer for Bipolar step motors
- Encoder readout function available
- Operates from +12 to 48 VDC
 - Phase currents from 0.3 to 3.0 Amp Peak



NOTE: Phase current of 2.7 Amp and above REQUIRES an additional heatsink, make sure the temperature of the bracket does not exceed 45° C.

- Hold current reduction capability with adjustable current and timeout settings
- Selectable Step Resolution from Full Step to 256x Microstepping
- Has three optically isolated control inputs and one optically isolated control output
- Pole Damping Technology™ integrated within driver board

Dip switches and a RS485 interface are built-in to the R325P Controller. A USB connection can be used by using the USB485 Converter Card (sold separately).

2. ELECTRICAL SPECIFICATIONS

Supply Voltage: +12 to 48 VDC
Phase Current: 0.3 to 3.0 Amps Peak



NOTE: Phase current of 2.7 Amp and above REQUIRES an additional heatsink, make sure the temperature of the bracket does not exceed 45° C.

I/O Specifications

3x Optically Isolated Inputs (1 fixed)
1x Optically Isolated Output

Minimum Motor Impedance: 1.5 mH

Note: The drive may behave unpredictably if the motor you are using has an inductance less than 1.5 mH.

3. OPERATING SPECIFICATIONS

Maximum Step Frequency: 2.5 MHz
 Operating Temperature: Low end – 0° C
 High end – Dependent on case temperature, bracket temperature must not exceed 45° C

Automatic Motor Holding Current reduction available from 0.3 to 2.5 Amps

Logic Timing

Minimum Step Pulse Width 200 nanoseconds
 Minimum Step Low Time 200 nanoseconds
 Maximum Power-Down Recovery Time 20 milliseconds

4. MECHANICAL SPECIFICATIONS

Size: 3.00" x 2.75" x 1.42"
 Weight: 3.2 oz
 Mounting: Four #6-32 screws, 2.42" x 2.45"
 Plate: Aluminum, Hard Anodized

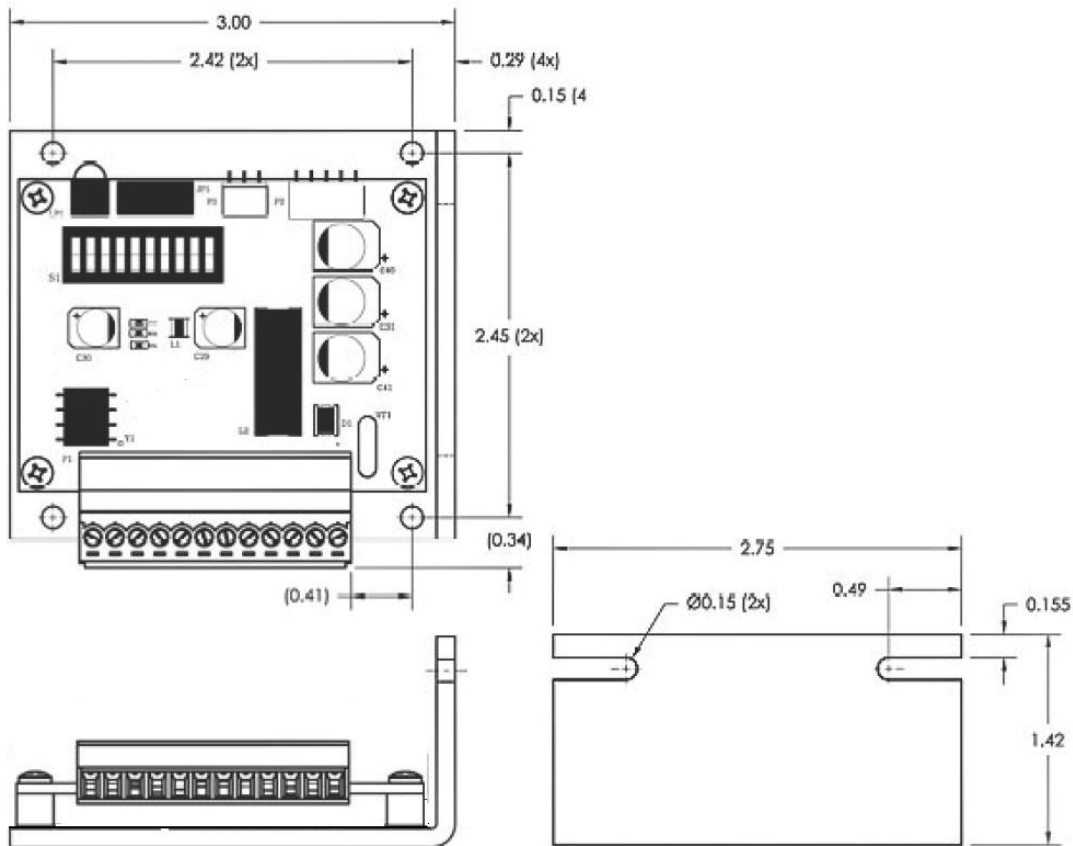

Figure 4.1

5. PIN ASSIGNMENTS

Mating Connectors

P1	AMP	640441-3
P2	AMP	640441-5
P3	Phoenix	1803675

P1 – RS485 bus Interface

P1 Configuration	
Pin No	Function
1	A Input (+ve)
2	Ground
3	B Input (-ve)

Table 5.1

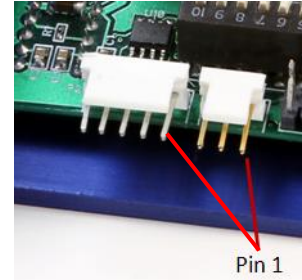

P1 & P2 Location of Pin 1

Image 5.1

P2 – Encoder Interface

P2 Configuration	
Pin No	Function
1	Ground
2	Index
3	A
4	+5VDC
5	B

Table 5.2

A motor with a single ended optical encoder must be used in order for the encoder feedback function to work. Connect the 5 wires from the encoder into P2 using a 5-Pin to 5-Pin connector which is provided with the Designer's Kit (purchased separately).

P3 – Motor/Controls/Power Interface

A 12-pin pluggable terminal strip connector P3 provides power and the step and direction control functions for the module. All of these signals are optically isolated. Open-collector drives are required to provide pulses for Step, levels for Direction, and Disable. The common +ve supply ranges from 5 VDC to 30 VDC with respect to the signal input; however if the supply is greater than 5 VDC then a resistor must be inserted in series with each signal line to limit the current to 10 mA.

P3 Configuration	
Pin No	Function
1	Common +ve External
2	Step (in)
3	Direction (in)
4	+5 VDC Internal
5	Disable (in)
6	Motor A+ (out)
7	Motor A- (out)
8	Motor B+ (out)
9	Motor B- (out)
10	Full Step Output
11	Power Ground
12	Power Positive

Table 5.3



Pin 1

P3 Connector – Pin 1 Location

Image 5.2



CAUTION: Connecting Motor phases (A, A Bar, B, B Bar) to the incorrect location while the R325P is powered will cause the board to burn. Be sure to insert motor phases into Pins 6 through 9, in the order of A, A Bar, B, and B Bar. It is recommended that power is connected last, so that all connections can be checked before power up.

6. CONNECTION SPECIFICATIONS

When using the Driver Only portion of the R325PE, use the dip switches for step resolution and current settings.

Using the R325PE as a Driver Unit Only

Step 1: Take off the jumper located on J1

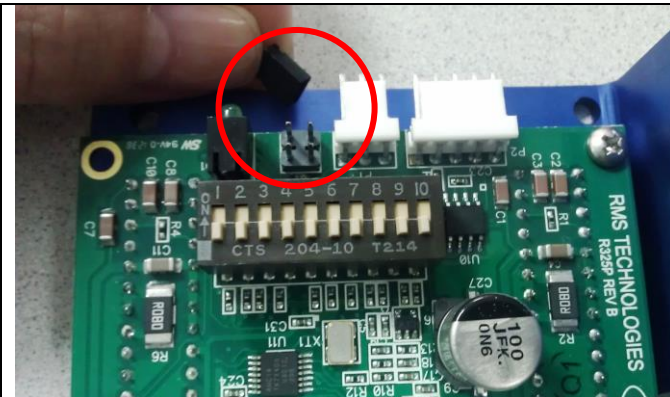

Remove the jumper from J1 in order for the R325PE to function as a driver ONLY.

Image 6.1

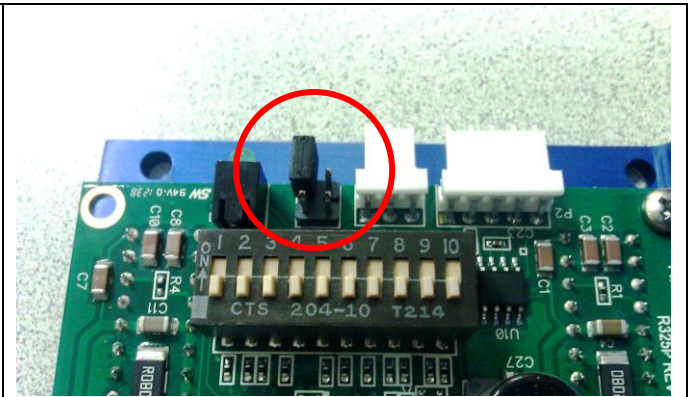

The jumper can be placed on 1 pin so that it is not misplaced.

Image 6.2

If using the R325PE as a Driver only, **be sure to connect the power supply last.**

Pin 1: Connect Pin 1 to Pin 4 to use the internal +5VDC. By using the internal +5VDC the I/O's will no longer be optically isolated. If optical isolation is still desired, use a separate +5VDC supply and connect the POSITIVE end of the supply to Pin 1. The NEGATIVE end will connect with the NEGATIVE end of your pulse generator.

Pin 2: Use a pulse generator or function generator to receive pulses into the R325P. Connect the POSITIVE end of the pulse generator to Pin 2. The NEGATIVE end will be connected to the NEGATIVE end of the +5VDC supply if using a separate power source. If using the internal +5VDC supply, connect the NEGATIVE end of the pulse generator to Power GROUND.

Pin 3: To switch the direction of motor rotation, connect Pin 3 with Pin 11, Power Ground. An open or closed connection to Power Ground will change the direction.

Pin 4: This is the internal +5VDC. Use this for testing purposes or if optical isolation of the inputs is not desired. It can output a max of 50 mAmps.

Pin 5: To enable the drive leave this Pin open, disable the drive connect Pin 5 with Pin 11 (Power Ground). An open or closed connection to Power Ground will enable and disable the drive, respectively. A closed connection will remove all power to the output motor leads (Pins 6 through 9).

Pin 6: Phase A Motor Connection

Pin 7: Phase A \bar{M} Motor Connection

Pin 8: Phase B Motor Connection

Pin 9: Phase \bar{B} Motor Connection



CAUTION: Connecting Motor phases (A, A Bar, B, B Bar) to the incorrect location while the R325P is powered will cause the board to burn. Be sure to insert motor phases into Pins 6 through 9, in the order of A, A Bar, B, and B Bar. It is recommended that power is connected last, so that all connections can be checked before power up.

Pin 10: When using the R325PE in Full Step mode, this output goes high.

Pin 11: Connect the NEGATIVE of the Power Supply to this terminal.

Pin 12: Connect the POSITIVE of the Power Supply to this terminal. (+12 to 48VDC)

Connecting the Power

The R325P requires a supply voltage between 12-48 VDC. First, connect the positive end of the power supply to positive terminal (Pin 12), and then connect the negative of the power supply to the Ground (Pin 11) on the R325P.



WARNING! Be careful not to reverse the polarity from the power supply to the driver. Reversing the connection will destroy your driver and void the warranty.

Connecting the Motor



WARNING! Make sure the power is OFF when connecting or disconnecting motors from the R325P. Damage will occur if the power is being supplied.

Please refer to your motor documentation for wiring color code.

Connect the corresponding Phase from the motor to the proper pin on the R325PE.

Motor Phase	P1 Connector
Phase A	Pin 6
Phase A-	Pin 7
Phase B	Pin 8
Phase B-	Pin 9

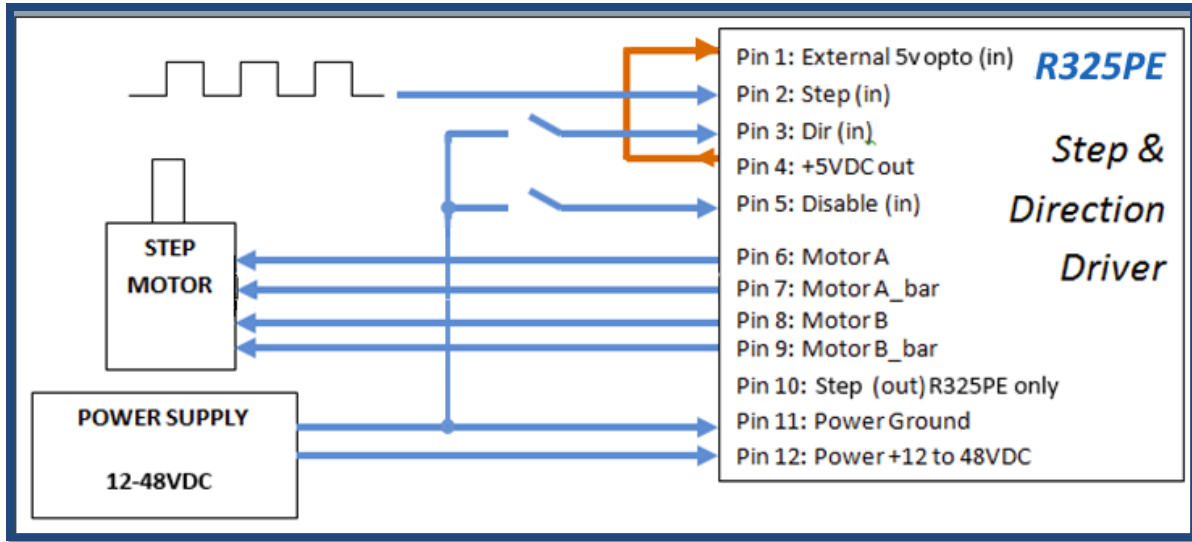

Figure 6.1

Using the R325P with more than 5V

You can choose to supply the optos with the R325P's internal 5V supply by jumping pins 1 to 4. But if you choose to use more than 5V, for example, a 24V supply and the step pulse train is also a 0 to 24V low-high signal, please use the following recommended resistor to limit the current to 10 mAmps. Note: no resistor will be needed on the actual opto supply line, pin 1.

Step & Direction lines have a 470 ohm internal resistor

Voltage:	5V	10V	12V	24V
Ohms needed:	0	500	1000	2000
Wattage rating:	0	¼ watt	¼ watt	¼ watt

Table 6.1

Disable line has a 1k ohm internal resistor

Voltage:	5V	10V	12V	24V
Ohms needed:	0	1000	1900	3800
Wattage rating:	0	1/8 watt	1/8 watt	¼ watt

Table 6.2

Configure the R325P using the DIP Switch

R325P DIP Switch Settings

Function	Run Current			
	SW1	SW2	SW3	SW4
0.3A	ON	ON	ON	ON
0.4A	OFF	ON	ON	ON
0.5A	ON	OFF	ON	ON
0.6A	OFF	OFF	ON	ON
0.8A	ON	ON	OFF	ON
1.0A	OFF	ON	OFF	ON
1.2A	ON	OFF	OFF	ON
1.4A	OFF	OFF	OFF	ON
1.6A	ON	ON	ON	OFF
1.8A	OFF	ON	ON	OFF
2.0A	ON	OFF	ON	OFF
2.2A	OFF	OFF	ON	OFF
2.4A	ON	ON	OFF	OFF
2.6A	OFF	ON	OFF	OFF
2.8A	ON	OFF	OFF	OFF
3.0A	OFF	OFF	OFF	OFF

Table 6.3



WARNING: Current of 2.7 Amp and above REQUIRES an additional heat sink; make sure the temperature of the bracket does not exceed 45° C

Hold Current (Percent of Run Current)		
Function	SW5	SW6
0%	ON	ON
33%	OFF	ON
66%	ON	OFF
100%	OFF	OFF

Table 6.4

Function	Step Resolution			
	SW7	SW8	SW9	SW10
Full Step*	OFF	OFF	OFF	OFF
2X	ON	OFF	OFF	OFF
4X	ON	ON	OFF	OFF
8X	ON	OFF	ON	OFF
16X	ON	ON	ON	OFF
32X	ON	OFF	OFF	ON
64X	ON	ON	OFF	ON
128X	ON	OFF	ON	ON
256X	ON	ON	ON	ON

*The power must be turned OFF when switching in and out of Full Step mode.

Table 6.5

Communicating with the R325PE

Step 1: Move all dipswitches to the OFF position. Place jumper on Pins 1 & 2.

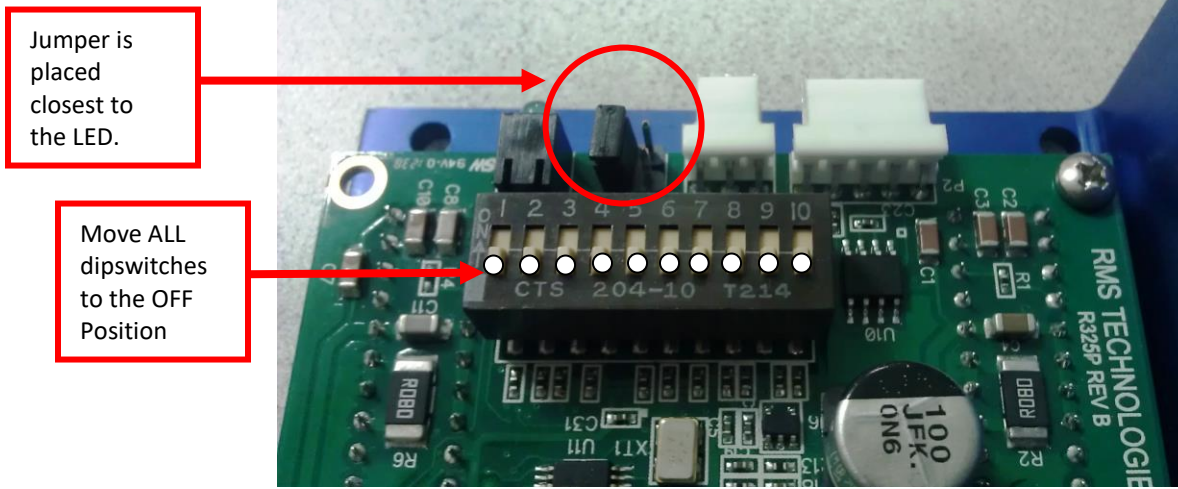

Image 6.3

1. Connect P1 to PC via RS485-232 Converter Card or USB485 Converter Card.
2. Set up HyperTerminal by selecting correct COM port
3. Settings for HyperTerminal is as follows: 57600, 8 bits, None, 1, None
4. The R325P Driver only version allows for changing the hold timeout settings, the amount of mixed decay, and to check the firmware revision level.

RS485-232 Converter Card

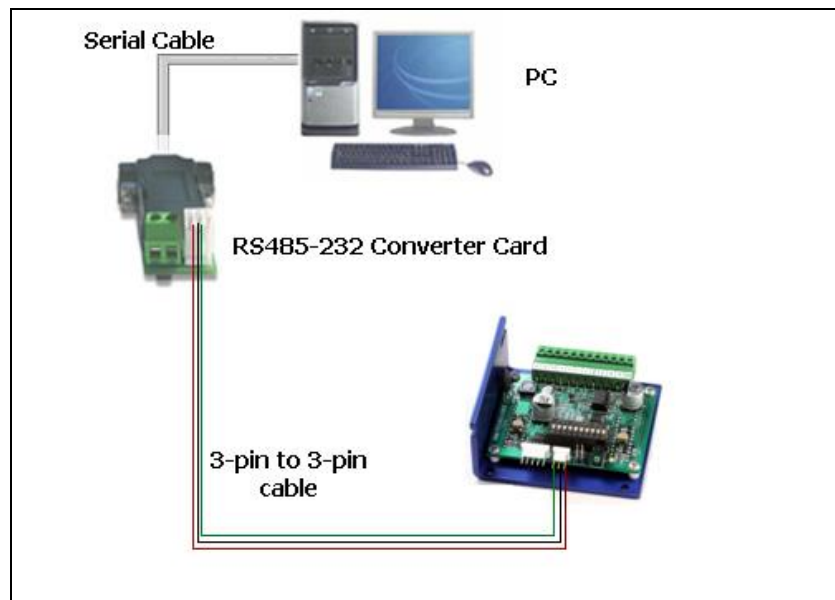

Figure 6.2

USB485 Converter Card

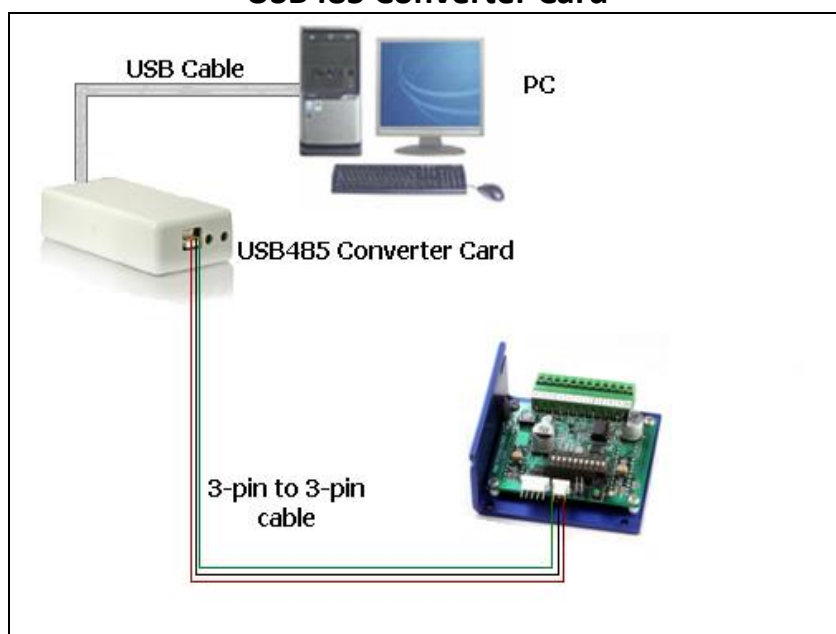

Figure 6.3

7. COMMAND TABLES

The R325PE can also be used as an indexer with closed loop controls. Basic controller commands can be used but users **cannot store programs to the unit**. This unit is commonly used with a user-created GUI or PLC's that can communicate commands via ASCII and serial port.

Basic Configuration Commands

Function	Query/Command	Code	Value	Minimum	Maximum	Default
Load Defaults	N	LD	None	-	-	-
Save Data	N	SD	None	-	-	-
Module Address	Q/C	MA	Numeric	65 (A)	90 (Z)	65 (A)
Baud Rate	Q/C	BR	Numeric	9600	57600	57600

Table 7.1

Axis Configuration Commands

Function	Query/Command	Code	Value	Minimum	Maximum	Default
Acceleration	Q/C	AC	Numeric	1	250	10
Hold Current	Q/C	HI	Numeric	0	3000	300
Hold Timeout	Q/C	HT	Numeric	100	5000	500
Min. Velocity	Q/C	MV	Numeric	250	15,000	250
Percent Fast Decay	Q/C	PF	Numeric	0	3	2
Run Current	Q/C	RI	Binary	300	3000	1000
Read Switches	Q	RS	Numeric	0	1023	-
Step Resolution	Q/C	SR	Numeric	1	256	8
Start Velocity	Q/C	SV	Numeric	250	15,000	1000
Velocity Limit	Q/C	VL	Numeric	250	50,000	15,000
Zero Position	C	ZP	None	-	-	-

Table 7.2

General Operation Commands

Function	Query/Command	Code	Value	Minimum	Maximum	Default
Absolute Position	C	AP	Numeric	-2,147,483,646	2,147,483,647	-
Current Position	Q/C	CP	Numeric	-2,147,483,646	2,147,483,647	-
Current Velocity	Q	CV	Numeric	0	50,000	-
Direction Velocity*	C	DV	Numeric	-50,000	50,000	-
Firmware Revision	Q	FR	Numeric	-	-	-
Home Axis	C	HA	Numeric	0	1	-
Move Status	Q	MS	Numeric	0	2	-
Position Move	C	PM	Numeric	-2,000,000,000	2,000,000,000	-
Step Back	C	SB	None	-	-	-
Step Forward	C	SF	None	-	-	-
Stop Motion	C	SM	None	-	-	-
Velocity Move *	Q	VM	Numeric	-50,000	50,000	-

Table 7.3

* Velocity Moves in the range -249 to 249 are not legal except zero

Encoder Commands

Function	Query/Command	Code	Value	Minimum	Maximum	Default
Current Encoder	Q	CE	Numeric	-16,777,215	16,777,215	-
Error Action	Q/C	EA	Numeric	0	2	2
Encoder Installed	Q/C	EI	Boolean	0	1	1 (TRUE)
Encoder Lines	Q/C	EL	Numeric	0	16,777,215	200
Encoder Mode	Q/C	EM	Numeric	1	2	2
Error Permitted	Q/C	EP	Numeric	0	16,777,215	Encoder Count
Error Read	Q	ER	Numeric	0	16,777,215	
Home Axis		HA	Boolean	0	1	0 = FWD
Motor Full Steps	Q/C	MF	Numeric	0	16,777,215	200
Zero Position		ZP				

Table 7.4

8. COMMANDS

Protocol Syntax

Command Format: #<Address><Command><value><CR><LF>
Example: #ACP1000<CR><LF>
Sets Driver A to the current position of 1000

To query a command use the following format

Query Format: #<Address><Command><CR><LF>
Example: #AAC<CR><LF>
Queries Driver A for the current Acceleration Value

The response would be in the following format

Response Format: *<Address><value>
Example: *AAC10
The Acceleration Value for Driver A is 10

<CR><LF> stand for "Carriage Return" and "Line Feed" respectively. These are NOT characters to be typed in. For direct keyboard users, these values are executed when the "Return" key is pressed. For programmers, a "Carriage Return" and "Line Feed" (also known as a "New Line") command needs to be executed after each command.

Table 8.1 – List of Commands

Command (Case Sensitive)	Operand	Example	Description														
HOMING & POSITIONING																	
HA	0 = Forward 1 = Reverse	<i>#AHA1</i> Motor turns in the reverse direction	<p>Home Axis - Command Only</p> <ul style="list-style-type: none"> - Causes the motor to move at the preset Start Velocity (SV) in the direction set by the command value. Motion stops when the index input of a device on the input pin goes TRUE then stops and sets Absolute Position and Current Encoder to zero. Motion can also stop by the entry of a Stop Motion (SM) command. - Forward is defined as the direction the motor turns when the 'Direction' input (P1-3) is set TRUE, or there is no connection to this input. <table border="1" data-bbox="743 726 1112 989"> <thead> <tr> <th colspan="2">P2 Configuration</th> </tr> <tr> <th>Pin No</th> <th>Function</th> </tr> </thead> <tbody> <tr> <td>1</td> <td>GND</td> </tr> <tr> <td>2</td> <td>Index</td> </tr> <tr> <td>3</td> <td>-</td> </tr> <tr> <td>4</td> <td>+5 V</td> </tr> <tr> <td>5</td> <td>-</td> </tr> </tbody> </table> <p style="text-align: center;"><i>Table 8.2</i></p>	P2 Configuration		Pin No	Function	1	GND	2	Index	3	-	4	+5 V	5	-
P2 Configuration																	
Pin No	Function																
1	GND																
2	Index																
3	-																
4	+5 V																
5	-																
CP	+/- 2,147,483,646	<i>#ACP1000</i> <i>Sets the current position to be 1000</i> <i>#ACP</i> <i>Returns the current position of the motor</i>	<p>Current Position - Command or Query.</p> <ul style="list-style-type: none"> - Returns the absolute position of the axis if no value is passed. Valid after power cycles if a Save Data Command is issued before power down. Can be used to set current position value. <p>The units are steps at the current step resolution (value becomes invalid with step resolution changes). The absolute position scale is set to zero by the Zero Position command (ZP) or the execution of a Home Axis (HA) command.</p>														
ZP	-	<i>#AZP</i>	<p>Zero Position - Command Only</p> <ul style="list-style-type: none"> - Sets the Current Position and the Encoder Position to zero <p>Note: This command functions differently between R325I and R325IE</p>														
VELOCITY & ACCELERATION																	
AC	1 - 250	<i>#AAC1</i> <i>Sets Acceleration to 1000 PPS^2</i>	<p>Acceleration - Command or Query</p> <p>Default = 10</p> <p>Used to shape the acceleration and deceleration ramps of position moves, and the rate of velocity change for velocity moves. Does not affect any of the basic step and direction move operations. Acceleration Factor * 1000 Pulses per Second</p>														

Command (Case Sensitive)	Operand	Example	Description
VELOCITY & ACCELERATION (cont.)			
AP	+/- 2,147,483,646	<i>#AAP1000</i> <i>Moves to the 1000th position.</i>	Absolute Position - Command Only - Used to make an absolute position move (in step resolution units).
CV	+/- 50,000	<i>#ACV</i>	Current Velocity - Query Only - Used when a Position Move (PM) or Velocity Move (VM) is in progress. Otherwise returns zero.
DV	+/- 50,000	<i>#ADV1000</i> <i>#ADV-1000</i> <i>Rotates CW at 1000 pps then CCW at 1000 pps. Use this to rotate CW & CCW.</i>	Direction Velocity – Command Only -This command is the exact same as Velocity Move (VM) with the addition of being able to ramp up and down when making moves from Positive to Negative. In the given example, it will rotate at 1000 pps. When issued #ADV-1000, it will ramp down to 0 then back up to 1000 pps but rotating in the opposite direction. <i>Note: No value is returned.</i>
MS	0 -2	<i>#AMS</i>	Move Status - Query Only - Reads Motion Status. Returns 0 for No Motion, 1 for Position Move, and 2 for Velocity Move.
MV	250 - 15,000	<i>#AMV500</i> <i>Sets minimum velocity to 500 SPS</i>	Minimum Velocity - Command or Query Default = 250 - Reads or sets the minimum velocity for both Position and Velocity command moves. The units are steps (at the current Step Resolution) per second.
PM	+/- 2,000,000,000	<i>#APM1000</i> <i>Makes a 1000 step move from the current position</i>	Position Move - Command Only - Causes a 'Relative Motion' Position Move, using an approximately trapezoidal profile. The initial velocity is defined by 'Start Velocity' (SV), the profile ramp is defined by 'Acceleration' (AC), and the 'Constant Velocity' step rate by 'Velocity Limit' (VL). 'Minimum Velocity' (MV) is used to ensure that the deceleration ramp does not set velocity to zero before the target position is reached. - It should be remembered that, while the 'Position Move' value defines the number of steps to be made from the current position, the value returned by 'Current Position' (CP) both before and after a 'Position Move' are on an 'Absolute' step count scale. - CP readings can be used to determine PM values required to reach any given position on the 'Absolute' step count scale. <i>Note: This command does not return a value.</i>

Command (Case Sensitive)	Operand	Example	Description
VELOCITY & ACCELERATION (cont.)			
SB	-	<i>#ASB</i> <i>Moves one step back</i>	Step Back - Command Only - Makes a single step move at the current step resolution - Forward is defined as the direction the motor moves with the 'Direction' input in the FALSE state or with no connection. Backwards is thus the direction the motor moves when the 'Direction' input is in the energized or TRUE state.
SF	-	<i>#ASF</i> <i>Moves one step forward</i>	Step Forward - Command Only - Makes a single step move at the current step resolution - Forward is defined as the direction the motor moves with the 'Direction' input in the FALSE state, or with no connection. Backwards is thus the direction the motor moves when the 'Direction' input is in the energized or TRUE state.
SM	-	<i>#ASM</i> <i>Stops any Position or Velocity move in progress</i>	Stop Motion Command Only - This command can be used to affect an end to any Position Move or Velocity Move in progress. It has no effect on motion produced by the Step and Direction inputs.
SV	250 – 15,000	<i>#ASV500</i> <i>Start velocity set to 500 PPS</i>	Start Velocity - Command or Query Default = 1000 - Reads or sets the velocity used for the first step in a position move in steps/sec. Value based on motor performance. This command must be used with Position Move (PM) command
VL	250 – 50,000	<i>#AVL5000</i> <i>Sets the velocity limit to 5000 steps/sec</i>	Velocity Limit - Command or Query Default = 15000 - Reads or sets the velocity used for Velocity Moves and the constant velocity portion of a Position Move.
VM	+/- 50,000	<i>#AVM1000</i> <i>Starts a velocity move of 1000 steps per second</i> <i>Use this to jog continuously in one direction.</i>	Velocity Move - Command Only - The sign of the value determines the direction (positive for forward and negative for backward) in which the velocity move is made. The value sets the step rate in steps per second at the current step resolution. Velocity cannot exceed Velocity Limit. - The move begins at the set 'Minimum Velocity' (MV) with the speed ramping to the command velocity at the rate set by 'Acceleration' (AC). Used for jogging in 1 direction. - Changes to new velocity values from new VM commands, will also occur at the rate set by 'Acceleration' (AC). <i>Note: No value is returned. Zero velocity makes an abrupt stop</i>

Command (Case Sensitive)	Operand	Example	Description
SETTING CURRENT			
HI	0-3000	<i>#AHI300</i> <i>Sets the Hold Current to 300mA (0.3A)</i>	Hold Current - Command or Query - 0 to 3000 Default = 300 - Reads or sets the motor Holding Current in 100 milliamps increments. The value does not round.
RI	300 - 3000	<i>#ARI1000</i> <i>Sets the run current to 1000 mA (1.0 Amp)</i>	Run Current - Command or Query Default = 1000 - Sets the motor Phase Current for any form of motion in milliamps. 300 = 300mA (0.3 Amp) 2500 = 2500mA (2.5 Amp) The last two numbers of the value are not read. 350 = 300mA, 2499 = 2400mA - The set 'Run Current' is maintained for a time set by 'Hold Timeout' (HT) before dropping to the current set by 'Hold Current' (HI) NOTE: Current of 2.7 Amp and above REQUIRES an additional heatsink, make sure the temperature of the bracket does not exceed 45° C
HT	100 -5000	<i>#AHT100</i> <i>Sets the Hold Timeout to 100 mS</i>	Hold Timeout - Command or Query Default = 500 - Reads or sets the time interval in milliseconds after any motor movement, before the motor current is changed from Run Current to Hold Current.
STORAGE & RECALL			
LD	-	<i>#ALD</i> <i>Loads all the default values</i>	Load Defaults - Command Only - Loads all of the unit Default parameter values. A Save Data (SD) command must be issued to have these values retained during a power cycle. Default values are: My Address 65 (A) Acceleration 10 Absolute Position 0 Percent Fast Decay 2 Hold Current 300 (0.3A) Hold Timeout 500 Minimum Velocity 250 Run Current 1000 (1.0A) Step Resolution 8 Start Velocity 1000 Velocity Limit 15000

Command (Case Sensitive)	Operand	Example	Description
SD	-	<i>#ASD</i> <i>Saves data</i>	Save Data - Command Only - This command causes a set of parameter values to be written to non-volatile memory. On power up the last set of values written are set to be the parameter initial values. -The parameters whose values are thus saved are: My Address Absolute Position Velocity Limit Minimum Velocity Start Velocity Acceleration Hold Timeout Step Resolution Run Current Hold Current Percent Fast Decay
MISC			
PF	0, 1, 2, 3	<i>#ACD1</i> <i>Sets Mixed Mode damping to 15%</i>	Percent Fast Decay - Command or Query Default = 2 - Allows the Damping Mode of the driver IC to be set. 0 = Fast Decay 1 = Mixed Mode 15% 2 = Mixed Mode 48% 3 = 100% The optimum setting will vary with motor inductance and step rate; however the default 'Mixed Mode' setting will work well with almost all motors.
MICROSTEPPING			
SR	1, 2, 4, 8, 16, 32, 64, 128, 256	<i>#ASR4</i> <i>Sets the step resolution to 4x</i>	Step Resolution - Command or Query Default = 8 - Reads or sets the current step resolution Allowed values are: 256 for 256x 128 for 128x 64 for 64x 32 for 32x 16 for 16x or 8 for 1/8 th stepping 4 for 1/4 stepping 2 for Half Stepping 1 for Full Stepping

Command (Case Sensitive)	Operand	Example	Description
QUERY COMMANDS			
FR	-	<i>#AFR</i>	Firmware Revision - Query Only - Returns 3 digit part code followed by 3 digit firmware revision value. Reply *AFR325PEV100 //R325PE firmware revision 1.00
MA	65 - 90	<i>#AMA88</i> <i>Sets the unit address to 88 ('X')</i>	My Address - Command or Query Default = 65 - Reads or sets the unit address. The value read or entered is the decimal value of the ASCII character designated as the unit address. (65 = 'A' and 90 = 'Z') The change to a new address is immediate, in that the command response will use the new address
RS	0-1023	<i>#ARS</i> <i>Reads the switch inputs</i>	Read Switches - Query Only - Reads the TRUE (1) or FALSE (0) state of the three optically coupled inputs, combined into a single three-bit value. This command is used to check the correct operation of this interface. - The value order of the inputs is 'Direction', 'Disable', and 'Step'; in descending order. 'Direction' has the value 4 (100) 'Disable' has the value 2 (010) 'Step' has the value 1 (001)
TI	-	<i>#ATI</i> <i>Reads the switch inputs</i>	Test Inputs - Query Only Step, Direction, and Disable all return a value in decimal form. The value order of the inputs is: 'Direction', 'Disable', and 'Step'; in descending order. 'Direction' has the value 4 (100) 'Disable' has the value 2 (010) 'Step' has the value 1 (001) Reply *AT13 // 3 = '011'
BR	9600 – 57600	<i>#ABR9600</i> <i>Sets the Baud Rate to 9600 bps</i>	Baud Rate – Query and Command Sets or reads the baud rate.

Command (Case Sensitive)	Operand	Example	Description
ENCODER VERSION COMMANDS			
EM	1, 2	<i>#AEM2</i> <i>Sets the Encoder Mode to 2</i>	Encoder Mode – Command or Query, Default = 2 - Reads or sets the operating mode of the Encoder Interface IC. A value of 1 returns one Encoder Count per Encoder Line. A value of 2 returns 2 Encoder Counts per Encoder Line. Only 1 and 2 are valid. (3x or Quadrature 4x is not permitted on this device). This is the first encoder setting to use.
EI	0, 1	<i>#AEI1</i> <i>Encoder Installed True</i>	Encoder Installed – Command or Query, Default = 1 - Read or set TRUE (1) or FALSE (0). This is the second encoder setting to enter in order to get started.
EL	0 - 16777215	<i>#AEL400</i> <i>Sets the encoder line count to 400</i>	Encoder Lines – Command or Query, Default = 400 - Encoder lines per motor revolution - Reads or sets the encoder line count. This is used in conjunction with Encoder Mode to calculate motor positions. Use EL with EM, Encoder Mode. For example, if EM=2 (default) and if your encoder is 400 CPR, then EL should be 2 x 400 = 800.
CE	+/- 16777215 (Motor Position in Encoder counts)	<i>#ACE</i> <i>*ACE12345</i>	Current Encoder – Query Only - Returns a 16-bit signed value, corresponding to the current motor position in encoder count. (See Encoder Mode). This is the main usage of the encoder. A separate PLC or controller can query the encoder position and compare it to the Current Position (CP), and issue adjusted moves based on the error seen.
EA	1, 2	<i>#AEA2</i> <i>Sets Error Action to Correct Mode</i>	Error Action – Command or Query, Default = 2 - Reads or sets a value that determines the action to be taken when an encoder error is found 1 – The error is reported and the motor is stopped 2 – The error is reported and the correction move is made
EP	0 – 16777215	<i>#AEP10</i>	Error Permitted - Command or Query - Reads or sets the maximum error allowed before Error Action is taken. Depending on the system configuration, the value is given in either Encoder Counts or Steps at the current Step Resolution. - If the product of Encoder Lines and Encoder Mode is larger than the product of Motor Steps and Step Resolution, then the value is in Encoder Counts. Otherwise it is in Steps. Note: The minimum value is the number of the finer resolution Encoder Counts or Steps required to make up one unit of the coarser resolution.

ER	0 - 16777215	#AER *AER5	Error Read – Query Only - Returns the current Encoder Error value. If the product of Encoder Lines and Encoder mode is larger than the product of Motor Steps and Step Resolution, then the error is in Encoder Counts. Otherwise it is in Steps.
MF	-	#AMF200 Sets Motor Fullsteps to 200	Motor Fullsteps (per revolution) – Command or Query Default = 200 Reads or sets the number of Fullsteps per motor revolution, i.e. A 1.8° motor will have a Fullstep count of 200.

Motion Profile Commands

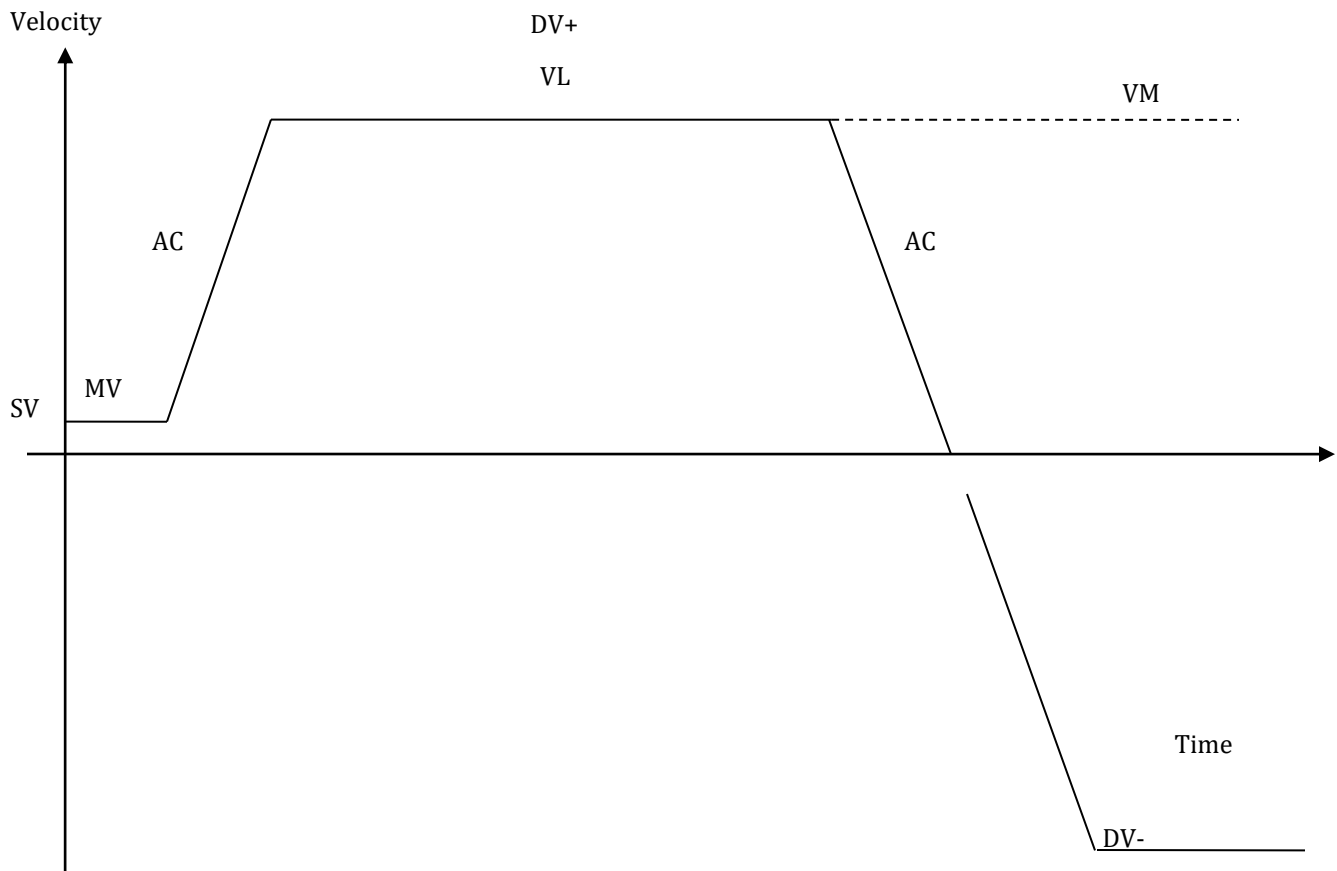

Graph 8.1

- SV: Start Velocity – the very first step it takes begins with the start velocity value (must be \geq MV)
- MV: Minimum Velocity
- AC: Acceleration (and deceleration)
- VL: Velocity Limit – sets the max speed the motor will rotate during a VM, PM or DV move command
- VM: Velocity Mode – rotates the motor at a fixed speed for continuous motion (use this to jog 1 direction only)
- DV: Direction Velocity – rotates the motor at a fixed speed for continuous motion, but allows the motor to change direction of rotation smoothly. Use this command rather than the VM command if jogging CW and CCW

9. Troubleshooting

R325P is not functioning correctly

Try putting the R325P into TEST mode by placing a jumper on Pins 3 & 4 of J1 as shown below. The motor should twitch back and forth slightly if the R325P is functioning properly.

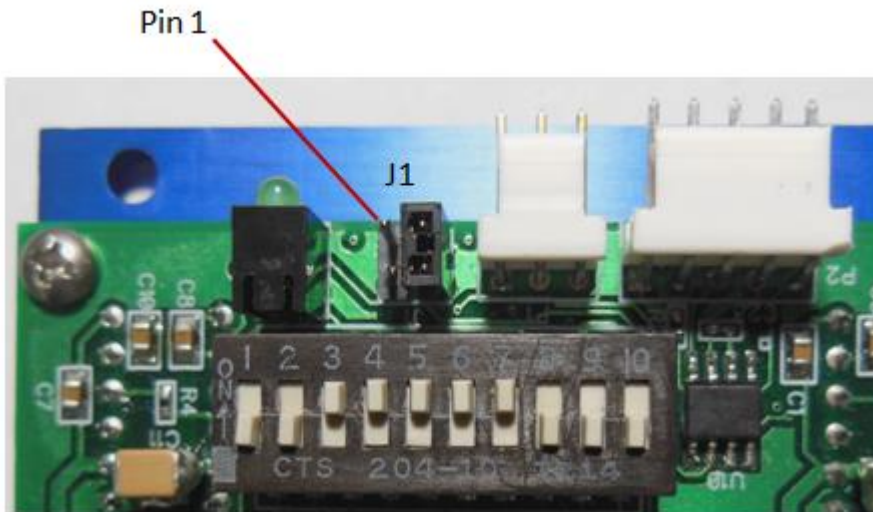

R325P not moving the motor (Step/Dip)

Verify that the 5V is being supplied to Pin 1.

The R325P is causing the motor to vibrate and jitter back and forth

Are the Motor phases switched? Be sure to check that motor wires are connected to Pins 6 through 9, in the order of A, A Bar, B, B Bar. To check which wires belong to one phase, take a Meter to measure resistance between any two wires. If there is a finite value between two of them, insert the wires into pins 6 and 7, OR pins 8 and 9. Insert the remaining two wires accordingly.

Technical Support

By Telephone: 408-919-0200

(Monday-Friday; 8:00 AM - 5:00PM Pacific)

On the Web: www.linengineering.com

Our technical support group is glad to work with you in answering your questions. If you cannot find the solution to your particular application, or, if for any reason you need additional technical assistance, please call technical support at **408-919-0200**.

10. Appendix A: Recommended Cable

Recommended Cable Configurations: DC Supply to Driver

Cable length, wire gauge and power conditioning devices play a major role in the performance of your RMS Technologies Driver and Motor.

NOTE: The length of the DC power supply cable to the Driver should not exceed 50 feet.

Example A –
Cabling Under
50 Feet, DC
Power

Example A demonstrates the recommended cable configuration for DC power supply cabling under 50 feet long. If cabling of 50 feet or longer is required, the additional length may be gained by adding an AC power supply cable.

Correct AWG wire size is determined by the current requirement plus cable length. Please see the Driver Supply Cable AWG Table in this Appendix.

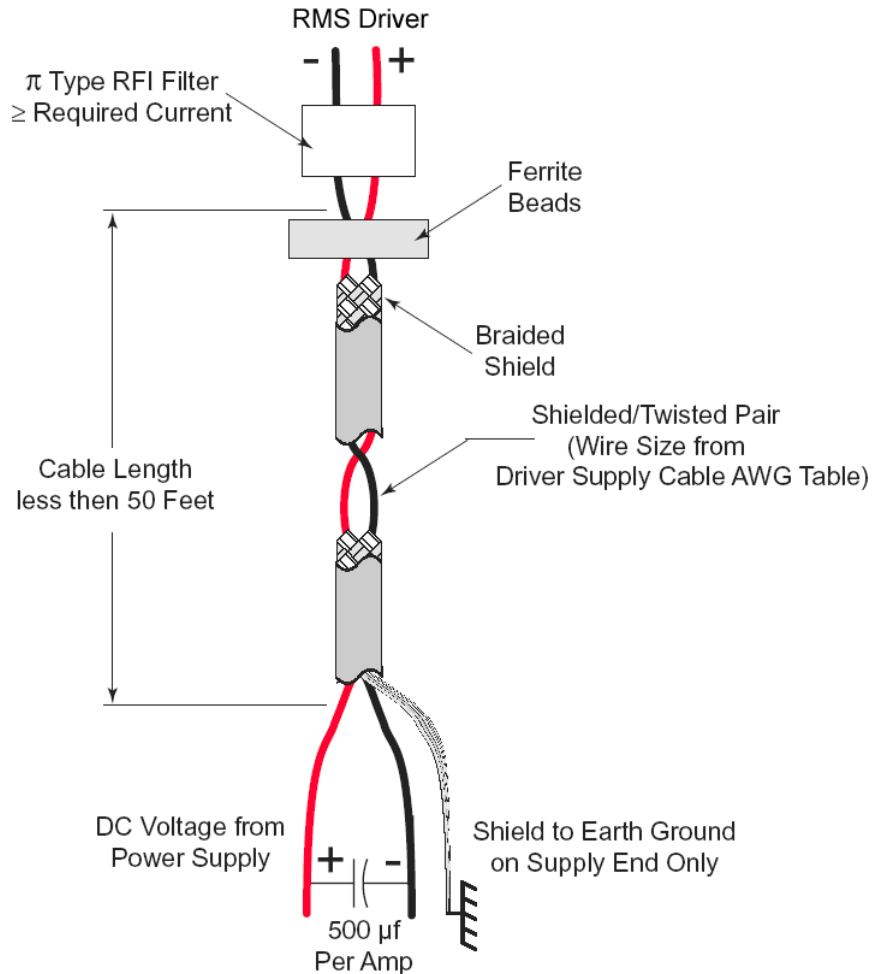

NOTE: These recommendations will provide optimal protection against EMI and RFI. The actual cable type, wire gauge, shield type and filtering devices used are dependent on the customer’s application and system.

Driver Supply Cable AWG Table					
1 Amp (Peak)					
Length (Feet)	10	25	50*	75*	100*
Minimum AWG	20	20	18	18	16
2 Amps (Peak)					
Length (Feet)	10	25	50*	75*	100*
Minimum AWG	20	18	16	14	14
3 Amps (Peak)					
Length (Feet)	10	25	50*	75*	100*
Minimum AWG	18	16	14	12	12
* Use the alternative methods illustrated in Examples B and C when the cable length is ≥ 50 feet. Also, use the same current rating when the alternate AC power is used					

Driver Supply Cable Wire Size

NOTE: Always use Shielded/Twisted Pairs for the Driver DC Supply Cable, the AC Supply Cable and the Driver to Motor Cable.

Recommended Cable Configurations: Driver to Motor

Cable length, wire gauge and power conditioning devices play a major role in the performance of your Driver and Motor.

NOTE: The length of the DC power supply cable between the Driver and the Motor should not exceed 50 feet.

Example A demonstrates the recommended cable configuration for the Driver to Motor cabling under 50 Feet long.

Correct AWG wire size is determined by the current requirement plus cable length. Please see the Driver to Motor Cable AWG Table in this Appendix.

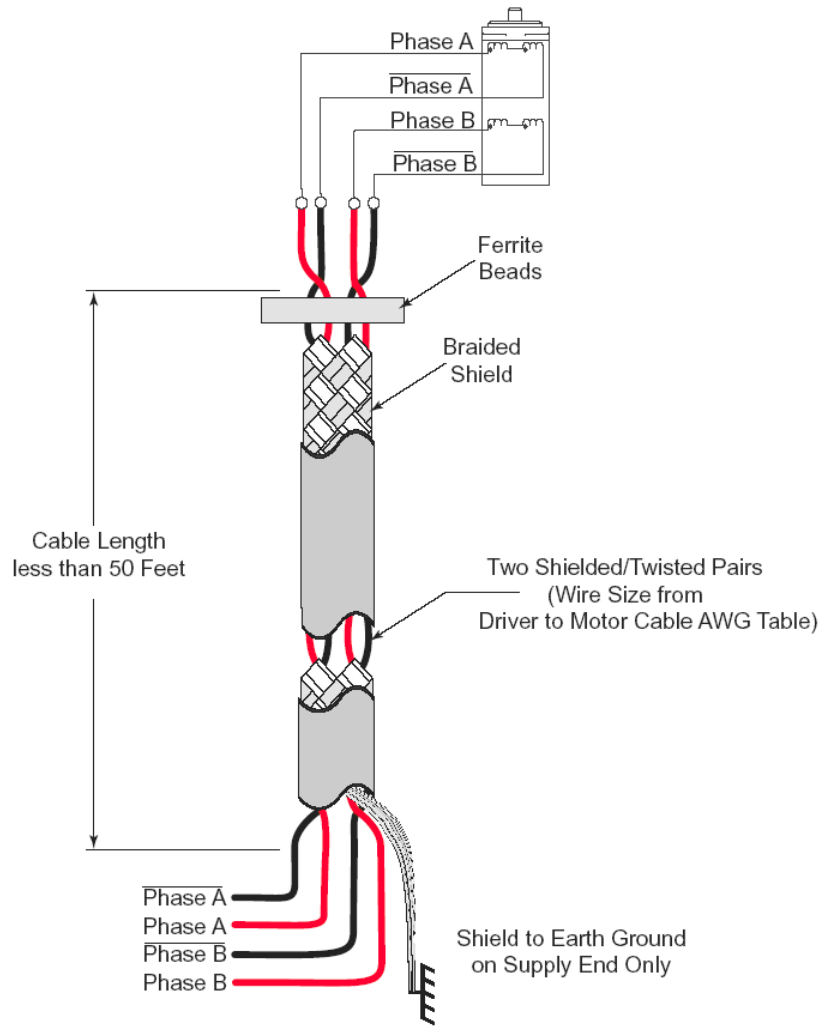

Example A - Cabling Under 50 Feet, Driver to Motor

If cabling of 50 feet or longer is required, the additional length can be gained by adding Common Mode Line Filters (2x)

*L ≈ 0.5 MH

* 0.5 MH is a typical starting point for the Common Mode Line Filters. By increasing or decreasing the value of L you can set the drain current to a minimum to meet your requirements.

Driver to Motor Cable AWG Table

1 Amp (Peak)						5 Amp (Peak)					
Length (Feet)	10	25	50	75	100	Length (Feet)	10	25	50	75	100
Minimum AWG	20	20	18	18	16	Minimum AWG	16	16	14	12	12

2 Amp (Peak)						6 Amp (Peak)					
Length (Feet)	10	25	50	75	100	Length (Feet)	10	25	50	75	100
Minimum AWG	20	18	16	14	14	Minimum AWG	14	14	14	12	12

3 Amp (Peak)						7 Amp (Peak)					
Length (Feet)	10	25	50	75	100	Length (Feet)	10	25	50	75	100
Minimum AWG	18	16	14	12	12	Minimum AWG	12	12	12	12	12

4 Amp (Peak)					
Length (Feet)	10	25	50	75	100
Minimum AWG	18	16	14	12	12

Driver to Motor Supply Cable Wire Size

NOTE: These recommendations will provide optimal protection against EMI and RFI. The actual cable type, wire gauge, shield type and filtering devices used are dependent on the customer’s application and system.

NOTE: Always use Shielded/Twisted Pairs for the Driver DC Supply Cable, the AC Supply Cable and the Driver to Motor Cable.

11. Appendix B: PF Value

For applications requiring ultimate smoothness of motion and extreme accuracy, the R325P driver can be programmed via RS485 to change the Percent Fast Decay rate, or, the PF value.

The Percent Fast Decay default is 2, or a mixed mode of 48%.

Mixed mode is a damping technique done to the driver IC. The following values indicate the choices for Percent Fast Decay:

PF Values (0 through 3):

0 = Slow Decay

1 = Mixed Mode 15%

2 = Mixed Mode 48%

3 = 100% Fast Decay

Generally speaking, applications that run at slow speeds are recommended to use a PF value of 1 or less. Fast speeds should use a PF value of 2 or more. Since the best PF value is dependent on the motor winding, loads, power supply voltage, and other factors, it is best to use an oscilloscope and a current probe device to view the current waveform and try different PF values. The following examples show good and bad waveforms when choosing different PF values.

- PF value 1
- Slow speeds
- Good waveform

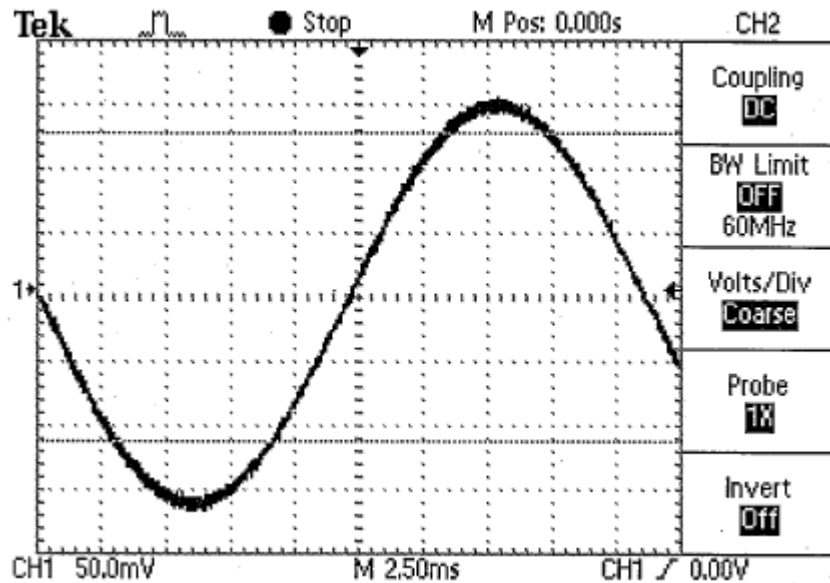

- PF value 3
- Slow speeds
- Bad waveform

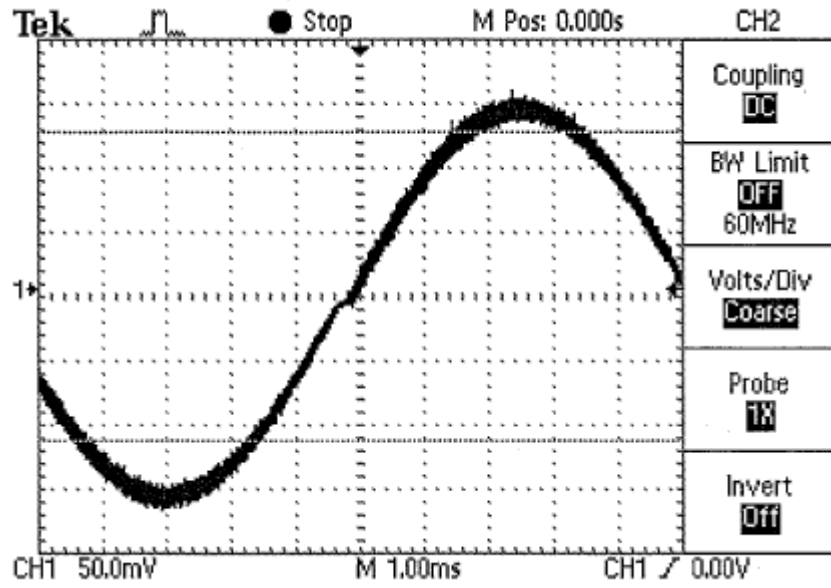

- PF value 1
- Fast speeds
- Bad waveform

