

1245HC

Fast-acting high current brick fuse



Product features

- 4818 (1245 metric) size
- Fast-acting high current brick fuse
- Compact design utilizes less board space
- Ceramic tube, silver plated brass end cap construction
- Designed to UL248-1/14
- Moisture sensitivity level (MSL): 1

Applications

Primary and secondary circuit protection:

- Server and desktop power supplies
- Energy storage systems
- E-bikes
- LED and general lighting
- Power distribution units
- Gaming console systems
- Voltage Regulator Module (VRM)
- Point-of-load (POL) protection
- High power battery packs
- Storage system power
- Basic power supplies

Agency information

cURus Recognition file number:
E91958, Guide JFHR2/JFHR8



Environmental compliance



Ordering part number

1245HC 60 -R TR

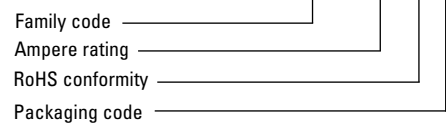

Packaging prefix

TR (1000 parts on a 13" diameter tape and reel)



Powering Business Worldwide

Electrical characteristics

Amp Rating	100% In minimum	350% In maximum
60 A ~ 100 A	4 hours	10 seconds

Product specifications

Part number	Current rating (A)	Voltage rating (Vac)	Interrupting rating @ rated voltage ^{1,2}		Typical resistance (mΩ)	Typical voltage drop (mV)	Typical pre-arcing ³ I ² t (A ² s)	Part marking	
			(A) Vac	(A) Vdc					
1245HC60-R	60	125	80 ⁴ 72 63 32	500	1000	0.58	65	950	60 A
1245HC80-R	80	125	72 63 32	500	1000	0.44	60	1700	80 A
1245HC100-R	100	125	72 63 32	500	1000	0.29	55	5000	100 A

1. AC Interrupting rating (Measured at designated voltage, 100% power factor random closing)

2. DC Interrupting rating (Measured at designated voltage, time constant of less than 50 microseconds, battery source)

3. Typical pre-arcing I²t are measured at 10In Current, DC battery bank, but not exceeding the interrupting rating, time constant of calibrated circuit less than 50 microseconds)

4. Internal qualification for 60 A @ 80 Vdc, UL Approval is pending

Dimensions- mm

Drawing not to scale

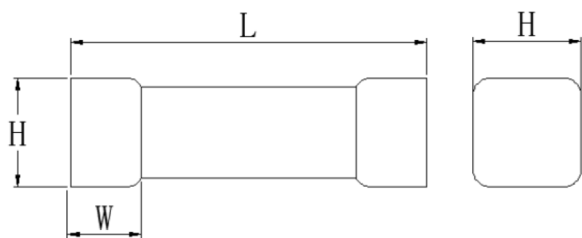

Rating	L	W	H
60 A ~ 100 A	12.30 ± 0.40	2.70 ± 0.20	4.50 ± 0.20

Recommended pad layout

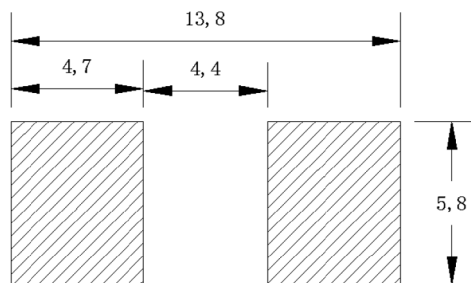

60 A - 70 A: Recommend trace thickness is 3 oz;
the minimum trace width is 22 mm
80 A - 100 A: Recommend trace thickness is 6 oz;
the minimum trace width is 33 mm
Recommended stencil thickness is 0.15 mm

General specifications

Operating temperature: -55 °C to +125 °C with proper derating factor applied

Thermal shock: MIL-STD-202, Method 107G -55 °C/+125 °C. Note: Number of cycles required 100 times

Humidity bias: MIL-STD-202, Method 103 +85 °C/85% RH, 1000 hours

Mechanical shock: Figure 1 of Method 213. Condition C, 100 g, 6 ms

Mechanical vibration: MIL-STD-202G, Method 20, 2 hours each of 3 orientations. Test from 10-55 Hz in 1 minute

Resistance to solder heat: MIL-STD-202G Method 210F, condition D (+260 °C, 10 s)

Solderability test: J-STD-002, Method B1 Steam aging 1 hour, Solder temperature +255 ± 5 °C, solder immersion time 5 s

High temperature operating life: MIL-STD-202 Method 108 Condition D, Steady state TA= +70 °C at 60% rated current

Packaging information - mm

1000 parts per 13" diameter reel

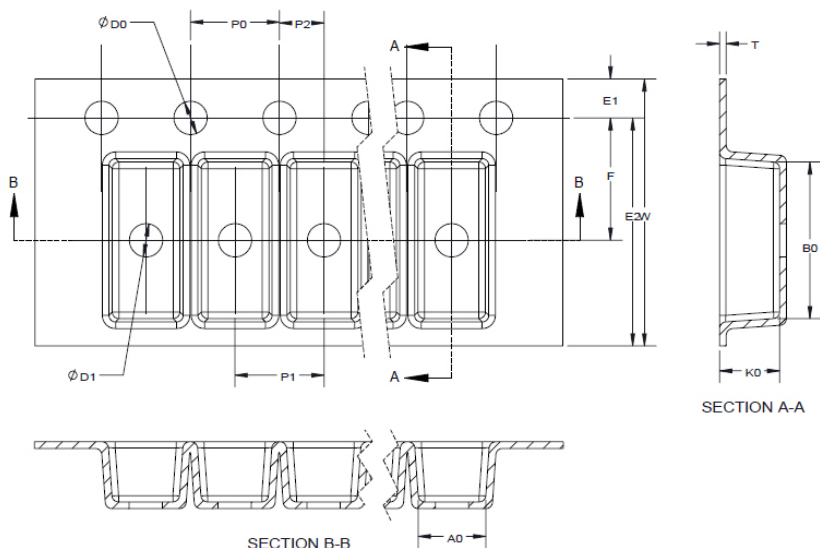

Dimension	millimeter
W	24.00
F	11.50
E1	1.75
E2	N/A
P0	4.00
P1	8.00
P2	2.00
D0	1.50
D1	1.50
A0	4.85
B0	12.75
K0	4.90
T	0.40

Reel dimension- mm

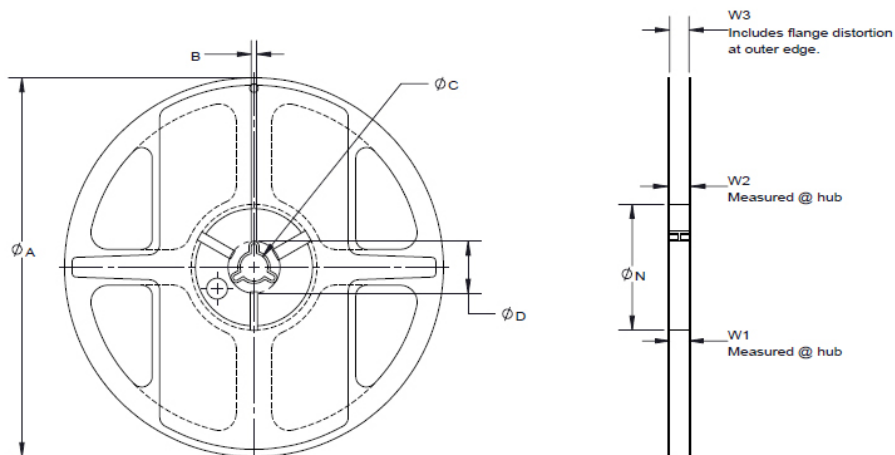

Dimension	millimeter
A	330 ± 1
B	2.5 ± 0.2
C	13.5 ± 0.2
D	N/A
N	100 ± 0.5
W1	$24.8 + .5/-0.5$
W2	30.4 max
W3	N/A

Temperature derating curve

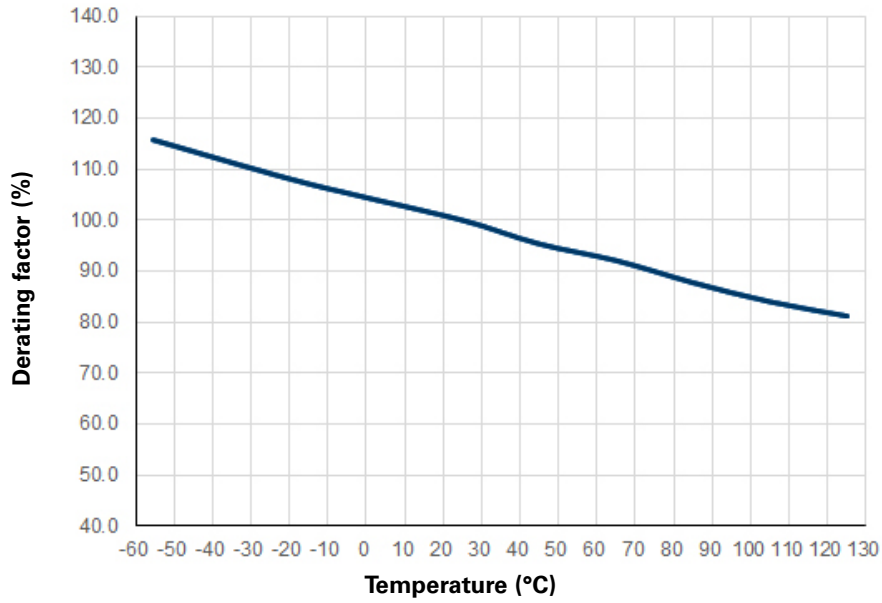

Current vs. time curve

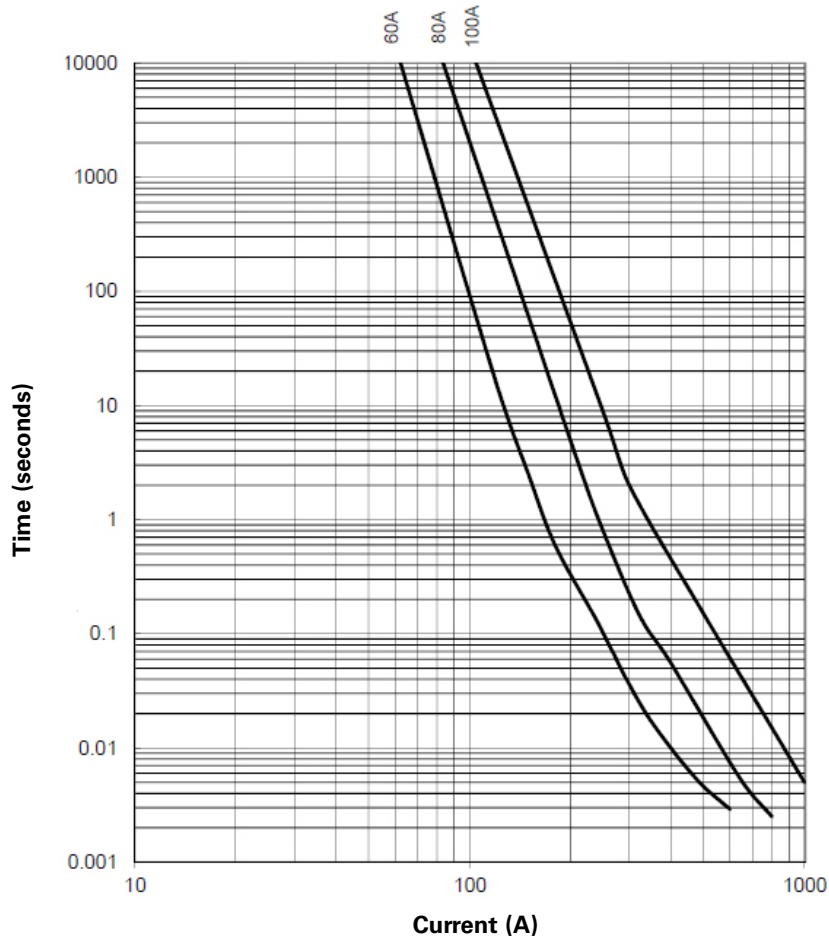

Wave solder profile

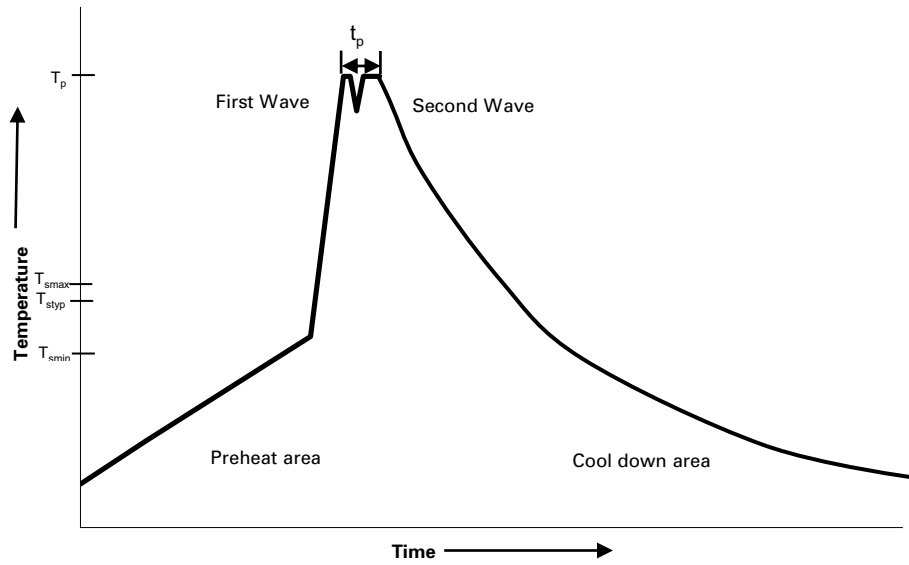

Reference EN 61760-1:2006

Profile feature	Standard SnPb solder	Lead (Pb) free solder
Preheat		
• Temperature min. (T_{smin})	100 °C	100 °C
• Temperature typ. (T_{styp})	120 °C	120 °C
• Temperature max. (T_{smax})	130 °C	130 °C
• Time (T_{smin} to T_{smax}) (t_s)	70 seconds	70 seconds
Δ preheat to max Temperature	150 °C max.	150 °C max.
Peak temperature (T_p)*	235 °C – 260 °C	250 °C – 260 °C
Time at peak temperature (t_p)	10 seconds max 5 seconds max each wave	10 seconds max 5 seconds max each wave
Ramp-down rate	~ 2 K/s min ~3.5 K/s typ ~5 K/s max	~ 2 K/s min ~3.5 K/s typ ~5 K/s max
Time 25 °C to 25 °C	4 minutes	4 minutes

Manual solder

+350 °C (4-5 seconds by soldering iron), generally manual/hand soldering is not recommended.

Solder reflow profile

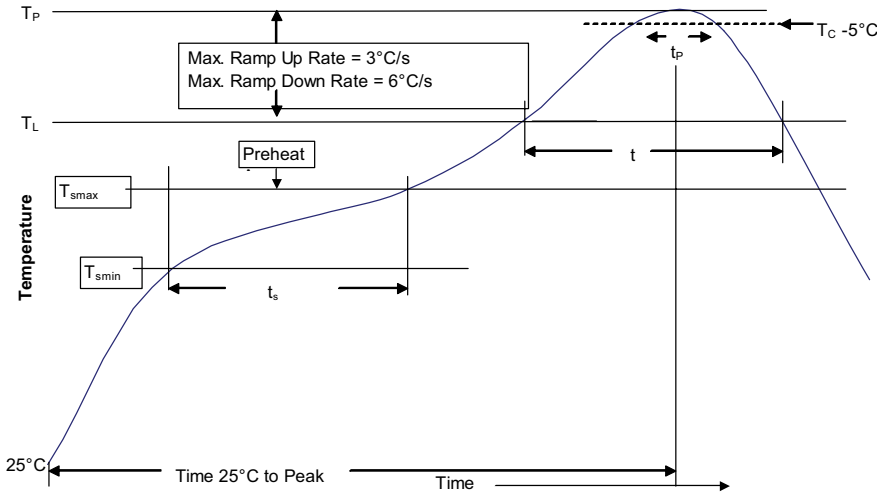

Table 1 - Standard SnPb solder (T_c)

Package thickness	Volume mm ³ <350	Volume mm ³ ≥350
<2.5 mm	235 °C	220 °C
≥2.5 mm	220 °C	220 °C

Table 2 - Lead (Pb) free solder (T_c)

Package thickness	Volume mm ³ <350	Volume mm ³ 350 - 2000	Volume mm ³ >2000
<1.6 mm	260 °C	260 °C	260 °C
1.6 – 2.5 mm	260 °C	250 °C	245 °C
>2.5 mm	250 °C	245 °C	245 °C

Reference J-STD-020

Profile feature	Standard SnPb solder	Lead (Pb) free solder
Preheat and soak	<ul style="list-style-type: none"> Temperature min. (T_{smin}) Temperature max. (T_{smax}) Time (T_{smin} to T_{smax}) (t_s) 	<ul style="list-style-type: none"> 100 °C 150 °C 60-120 seconds
Ramp up rate T_L to T_p	3 °C/ second max.	3 °C/ second max.
Liquidous temperature (T_L) Time (t_L) maintained above T_L	<ul style="list-style-type: none"> 183 °C 60-150 seconds 	<ul style="list-style-type: none"> 217 °C 60-150 seconds
Peak package body temperature (T_p)*	Table 1	Table 2
Time (t_p)* within 5 °C of the specified classification temperature (T_c)	20 seconds*	30 seconds*
Ramp-down rate (T_p to T_L)	6 °C/ second max.	6 °C/ second max.
Time 25 °C to peak temperature	6 minutes max.	8 minutes max.

* Tolerance for peak profile temperature (T_p) is defined as a supplier minimum and a user maximum.

Life Support Policy: Eaton does not authorize the use of any of its products for use in life support devices or systems without the express written approval of an officer of the Company. Life support systems are devices which support or sustain life, and whose failure to perform, when properly used in accordance with instructions for use provided in the labeling, can be reasonably expected to result in significant injury to the user.

Eaton reserves the right, without notice, to change design or construction of any products and to discontinue or limit distribution of any products. Eaton also reserves the right to change or update, without notice, any technical information contained in this bulletin.

Eaton
Electronics Division
1000 Eaton Boulevard
Cleveland, OH 44122
United States
Eaton.com/electronics

© 2021 Eaton
All Rights Reserved
Printed in USA
Publication No. ELX1000
May 2021

Eaton is a registered trademark.
All other trademarks are property of their respective owners.

Follow us on social media to get the latest product and support information.

