

Customer Information Sheet

DRAWING No.: M80-315 TO M80-317

SHEET 2 OF 2

IF IN DOUBT - ASK

(C)

NOT TO SCALE

THIRD ANGLE PROJECTION

ALL DIMENSIONS IN mm

SPECIFICATIONS:

MATERIALS:
 BODY, SLEEVE, INNER CONTACT AND LATCHING COLLAR = COPPER ALLOY
 INSULATOR = PTFE

FINISH:
 BODY, SLEEVE, INNER CONTACT = GOLD
 LATCHING COLLAR = NICKEL

ELECTRICAL:
 FREQUENCY RANGE = 6GHz
 IMPEDANCE = 50Ω
 V.S.W.R. = 1.05 + (0.04 x FREQUENCY) GHz MAX
 CONTACT RESISTANCE = 6mΩ MAX

INSULATION RESISTANCE = 10⁶MΩ @250V AC
 OPERATING VOLTAGE = 180V AC @ 500mA
 MAXIMUM VOLTAGE = 1,000V AC

MECHANICAL:
 DURABILITY = 500 OPERATIONS
 INSERTION FORCE = 8N MAX
 WITHDRAWAL FORCE = 0.5N MIN
 CONTACT REPLACEMENT IN INSULATOR = 5 TIMES

ENVIRONMENTAL:
 TEMPERATURE RANGE = -55°C TO +125°C

3.00⁰_{-0.10}
 SQUARE

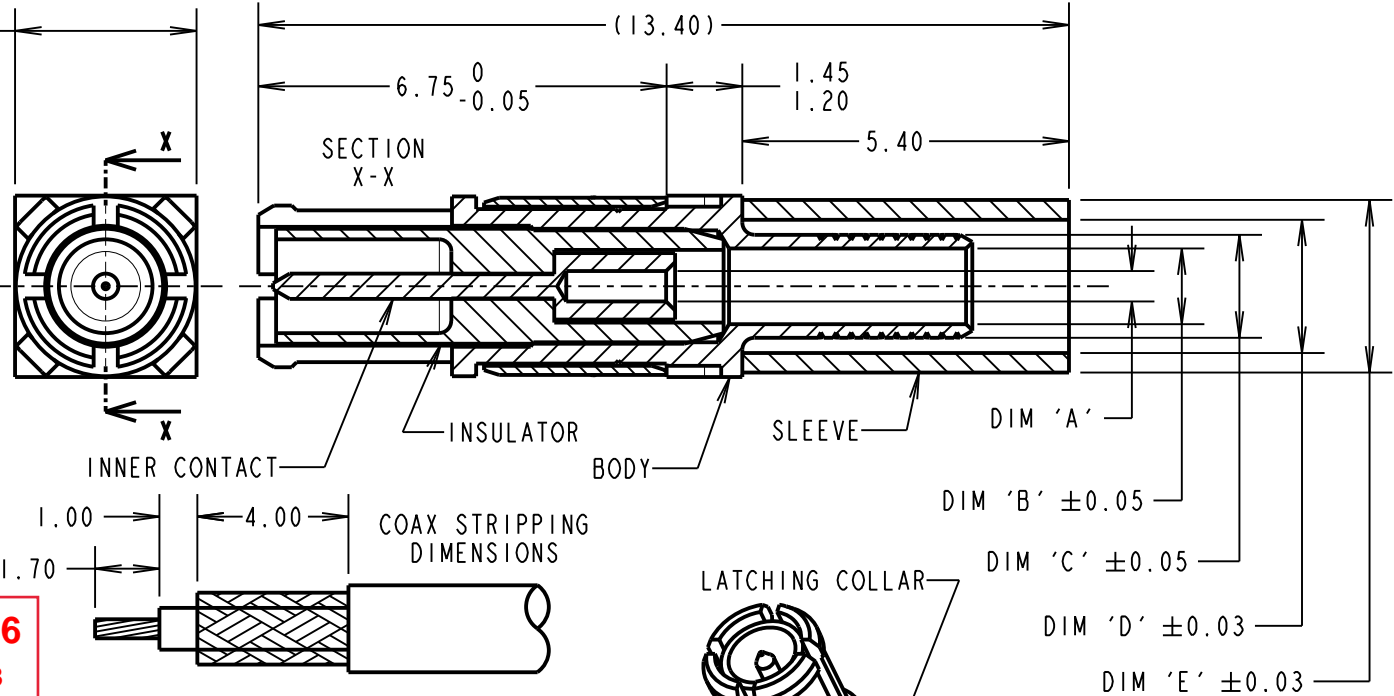

OBSOLETE - M80-316

Last Time Buy 18-May-2018

NOTES:

- CONNECTOR COMES SUPPLIED AS A KIT OF PARTS: BODY, INSULATOR, AND LATCHING COLLAR ARE PRE-ASSEMBLED, SLEEVE AND INNER CONTACT ARE SEPARATE.
- RECOMMENDED HAND CRIMP TOOL FOR INNER CONTACT = Z80-292 WITH POSITIONER Z80-291. RECOMMENDED HAND CRIMP TOOL AND DIE SET FOR SLEEVE = Z80-293.
- CONTACT EXTRACTION TOOL = Z80-290
- FOR ALL OTHER ELECTRICAL/MECHANICAL REQUIREMENTS, SEE COMPONENT SPECIFICATION C005XX (LATEST ISSUE).

PART No.	CABLE DIAMETER (TYPE)	DIM 'A'	DIM 'B'	DIM 'C'	DIM 'D'	DIM 'E'
M80-315	∅2.0mm (RG178)	∅0.50 ±0.05	∅1.25	∅1.70	∅2.20	∅2.85
M80-316	∅2.4mm (PTFE CELLULAR)	∅0.35 ±0.05/0	∅1.25	∅1.70	∅2.70	∅3.20
M80-317	∅2.7mm (RG174, 179, 316)	∅0.70 ±0.05	∅1.75	∅2.35	∅2.85	∅3.50

MGP	6	03.01.13	11898
NAME	ISS.	DATE	C/NOTE
APPROVED: MGP			
CHECKED: SB			
DRAWN: W. J. BOURNE			
CUSTOMER REF.:			
ASSEMBLY DRG:			

HARWIN

www.harwin.com
 technical@harwin.com

THIS DRAWING AND ANY INFORMATION OR DESCRIPTIVE MATTER SET OUT HEREON ARE CONFIDENTIAL AND COPYRIGHT PROPERTY OF THE HARWIN GROUP AND MUST NOT BE DISCLOSED, LOANED, COPIED OR USED FOR MANUFACTURING, TENDERING OR FOR ANY OTHER PURPOSE WITHOUT THEIR WRITTEN PERMISSION.

TOLERANCES
 X. = ±1mm
 X.X = ±0.25mm
 X.XX = ±0.10mm
 X.XXX = ±0.01mm
 ANGLES = ±5°
 UNLESS STATED

MATERIAL:
 SEE ABOVE
FINISH: SEE ABOVE
S/AREA: mm²

TITLE: DATAMATE MIX-TEK
 COAX CONTACT
 MALE STRAIGHT CRIMP

DRAWING NUMBER:
 M80-315 TO M80-317

SHT
 2 OF 2