

Customer Information Sheet

DRAWING No.: M50-315XX42R

IF IN DOUBT - ASK

©

NOT TO SCALE

THIRD ANGLE PROJECTION

ALL DIMENSIONS IN mm

**TAPE DETAILS FOR
15, 20, 22 AND 25 WAYS ONLY**

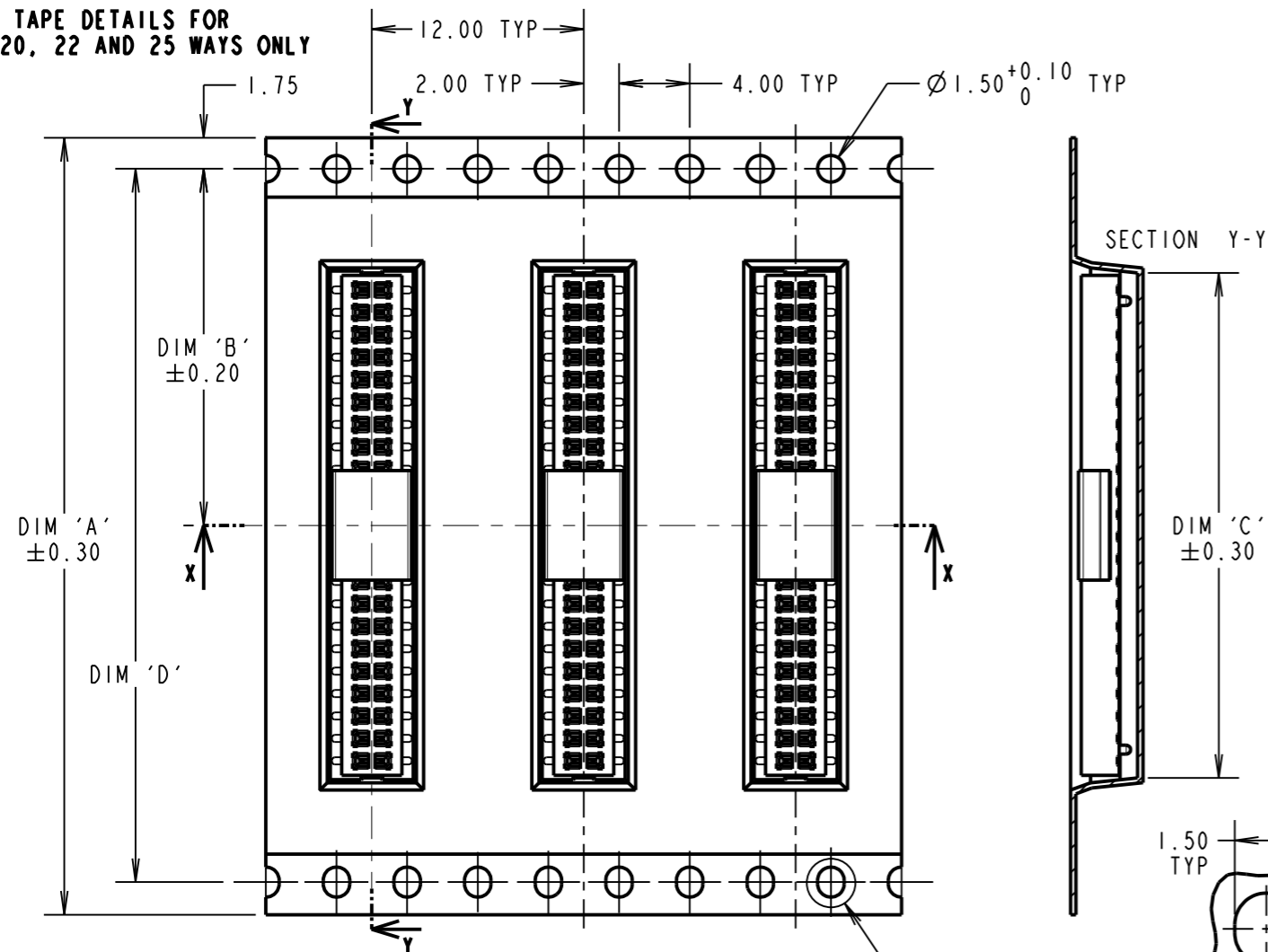

**TAPE DETAILS FOR
03, 04, 05, 06, 08 & 10 WAYS ONLY**

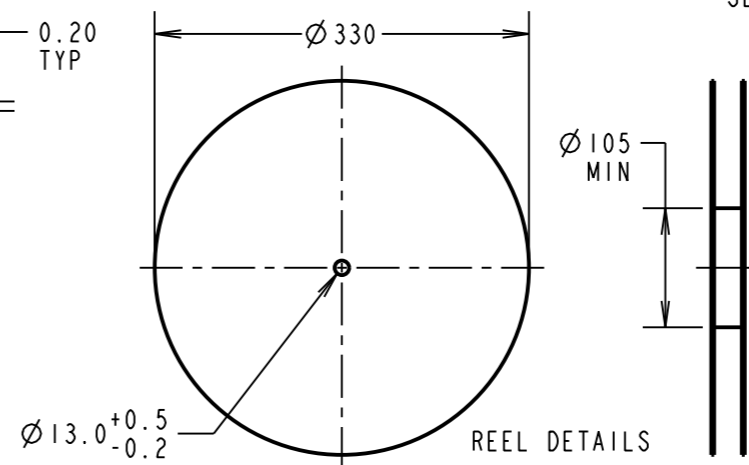
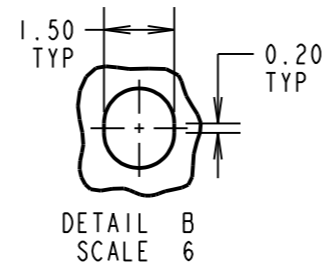
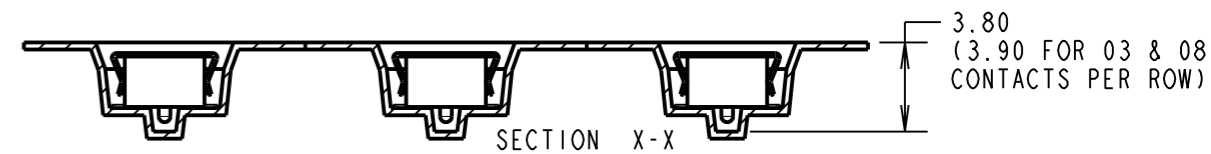
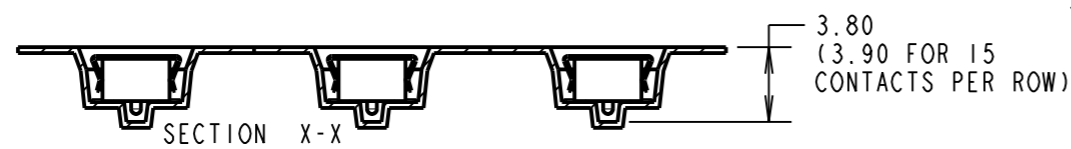
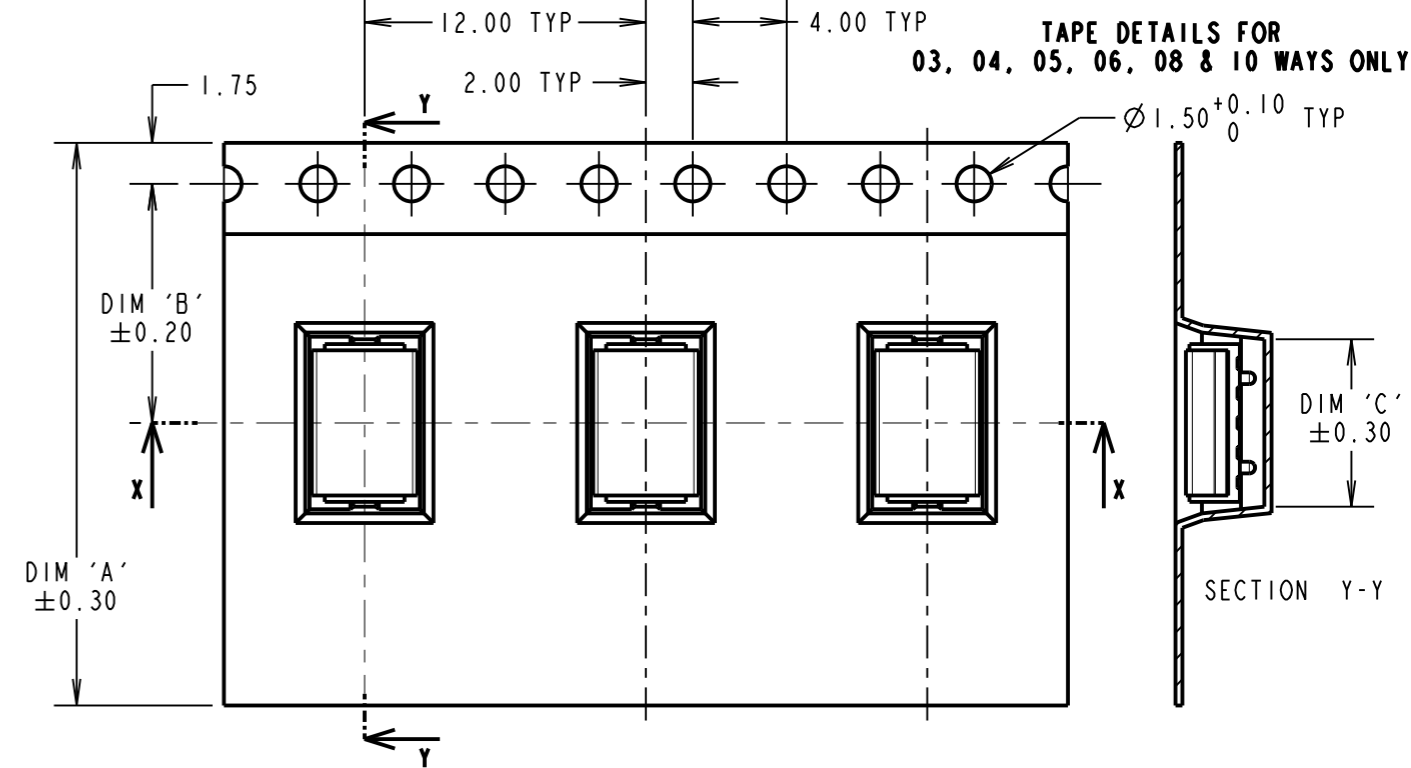

OBSOLETE
All other size/finish combinations
not listed below

ORDER CODE: **M50-315XX42R**

No. OF CONTACTS PER ROW:
03, 04, 05, 06, 08,
10, 15, 20, 22, 25

FINISH:
42 = GOLD FLASH + 100% TIN OVER NICKEL

REELED PART No.	DIM 'A'	DIM 'B'	DIM 'C'	DIM 'D'	PACK SIZE
M50-3150342R			4.55		1400
M50-3150442R	16.00	7.50	5.78		
M50-3150542R			7.15	N/A	
M50-3150642R		10.20	8.30		1300
M50-3150842R	24.00		11.25		
M50-3151042R		11.50	13.40		
M50-3151542R	32.00	14.20	20.10	28.40	1400
M50-3152042R			26.10	40.40	
M50-3152242R	44.00	20.20	28.60	40.40	1300
M50-3152542R			32.45	40.40	

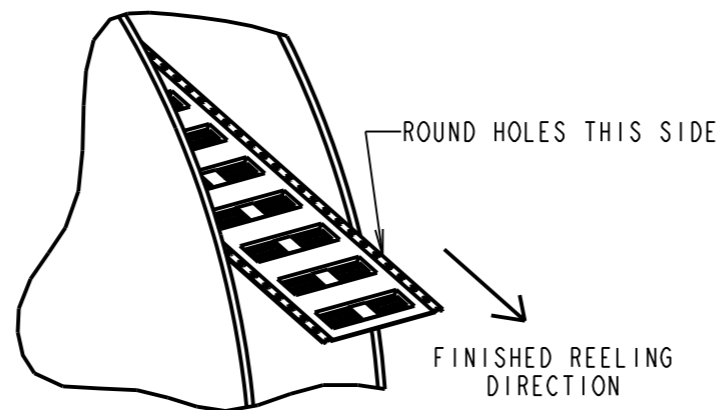

Active products:

- M50-3150342R
- M50-3150542R
- M50-3151042R
- M50-3151542R
- M50-3152042R
- M50-3152542R

MSP	10	17.08.17	20750
NAME	ISS.	DATE	C/NOTE
APPROVED: M.PERREN			
CHECKED: M.PLESTED			
DRAWN: R.ADDE			
CUSTOMER REF.:			
ASSEMBLY DRG:			

- NOTES:
- PRODUCT IS TAPE AND REELED IN GENERAL ACCORDANCE WITH EIA-481 (ELECTRONIC INDUSTRIES ASSOCIATION).
 - CUMULATIVE TOLERANCE OVER 10 PITCHES = ± 0.20 mm
 - FOR CONNECTOR DETAILS AND SPECIFICATIONS SEE SHEET 4.

HARWIN

www.harwin.com
technical@harwin.com

THIS DRAWING AND ANY INFORMATION OR DESCRIPTIVE MATTER SET OUT HEREON ARE CONFIDENTIAL AND COPYRIGHT PROPERTY OF THE HARWIN GROUP AND MUST NOT BE DISCLOSED, LOANED, COPIED OR USED FOR MANUFACTURING, TENDERING OR FOR ANY OTHER PURPOSE WITHOUT THEIR WRITTEN PERMISSION.

TOLERANCES
X. = ± 1 mm
X.X = ± 0.25 mm
X.XX = ± 0.10 mm
X.XXX = ± 0.01 mm
ANGLES = $\pm 5^\circ$
UNLESS STATED

MATERIAL:
SEE SHEET 4
FINISH: SEE ABOVE
S/AREA: mm²

TITLE: 1.27mm PITCH DIL SMT VERT
LOW PROFILE SOCKET ASSY
(TAPE & REEL)

DRAWING NUMBER: **M50-315XX42R**
SHT 3 OF 4

Customer Information Sheet

DRAWING No.: M50-315XX42R

IF IN DOUBT - ASK

©

NOT TO SCALE

THIRD ANGLE PROJECTION

ALL DIMENSIONS IN mm

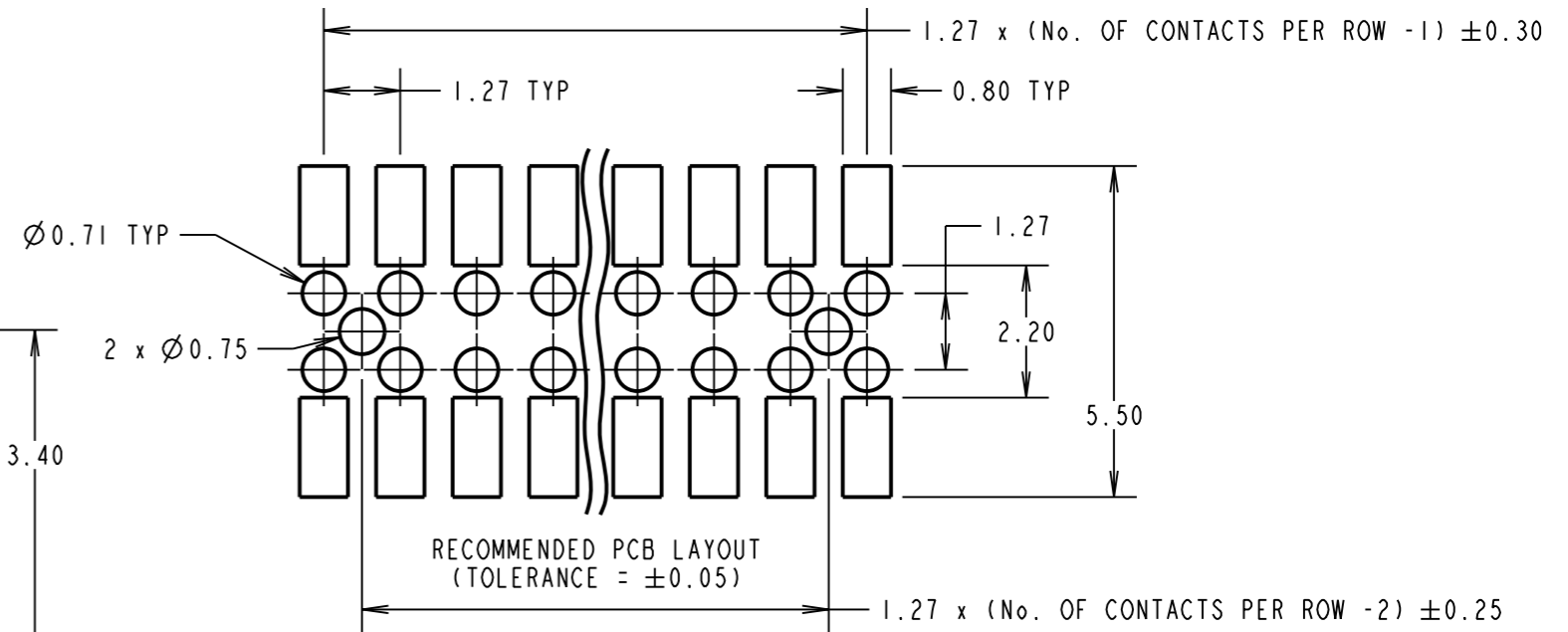
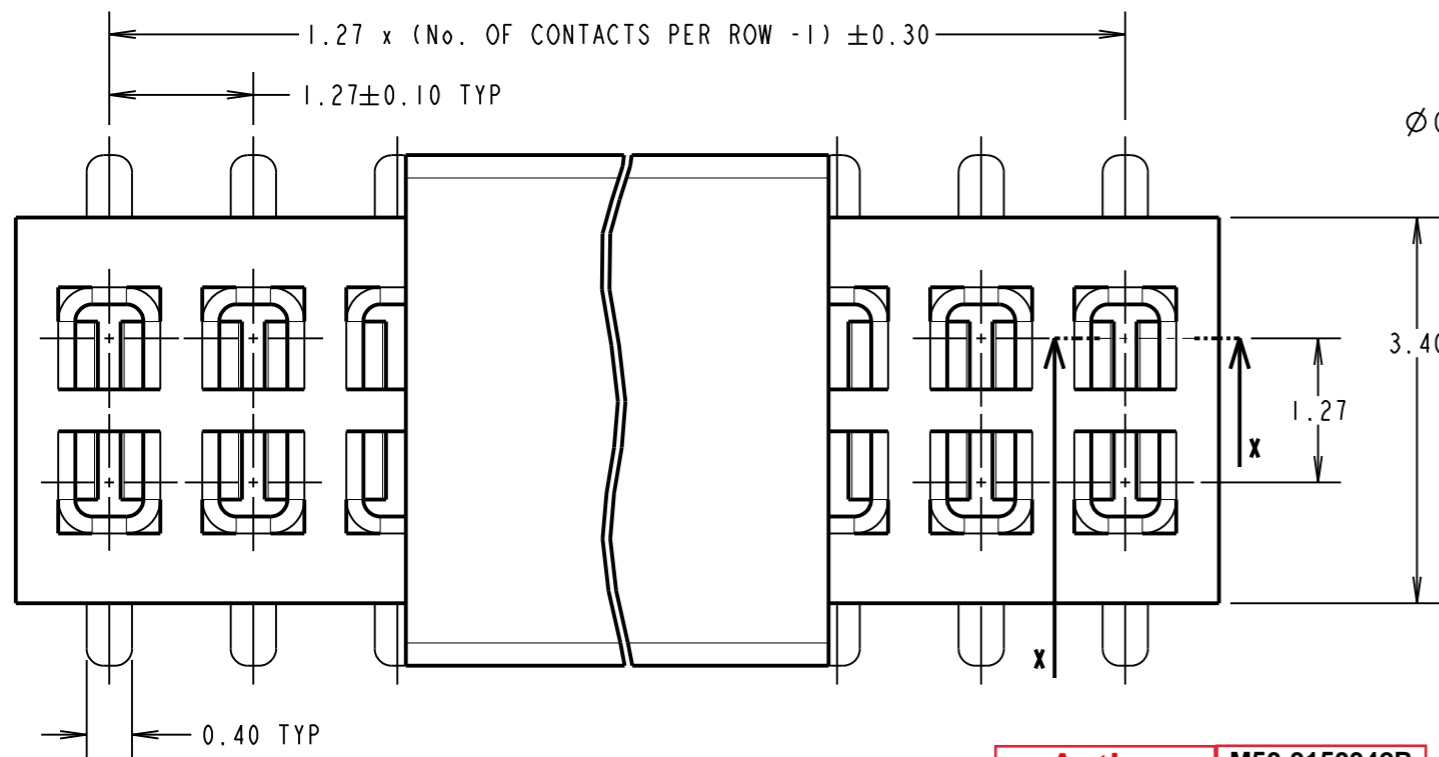

OBSOLETE
All other size/finish combinations not listed below

Active products:
M50-3150342R
M50-3150542R
M50-3151042R
M50-3151542R
M50-3152042R
M50-3152542R

ORDER CODE: **M50-315XX42R**
No. OF CONTACTS PER ROW: 03, 04, 05, 06, 08, 10, 15, 20, 22, 25
FINISH: 42 = GOLD FLASH + 100% TIN OVER NICKEL

SPECIFICATION:
MATERIAL:
MOULDING = NYLON-6T, UL94V-0, BLACK
CONTACTS = PHOSPHOR BRONZE
FINISH:
CONTACTS = 1.27μ NICKEL ALL OVER, GOLD FLASH ON CONTACT AREA, 2.54μ 100% TIN ON TAILS
ELECTRICAL:
CURRENT RATING = 1A
CONTACT RESISTANCE = $20m\Omega$ MAX
INSULATION RESISTANCE = $1000M\Omega$ MIN
DIELECTRIC WITHSTANDING = 500V AC FOR ONE MINUTE
MECHANICAL:
DURABILITY = 300 CYCLES MIN
INSERTION FORCE = 1.5N MAX PER CONTACT
WITHDRAWAL FORCE = 0.2N MIN PER CONTACT
ENVIRONMENTAL:
TEMPERATURE RANGE = -40°C TO $+105^\circ\text{C}$
PACKING:
REEL
FOR COMPLETE SPECIFICATION, SEE COMPONENT SPECIFICATION C029XX (LATEST ISSUE)

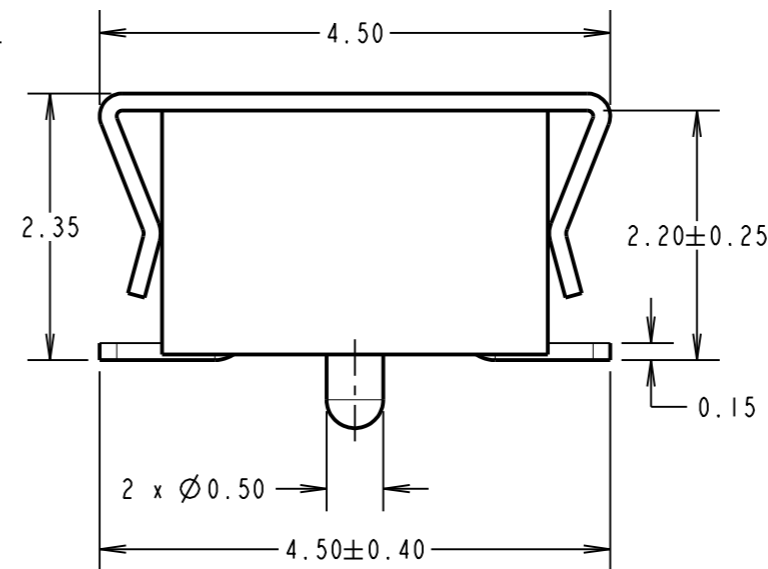
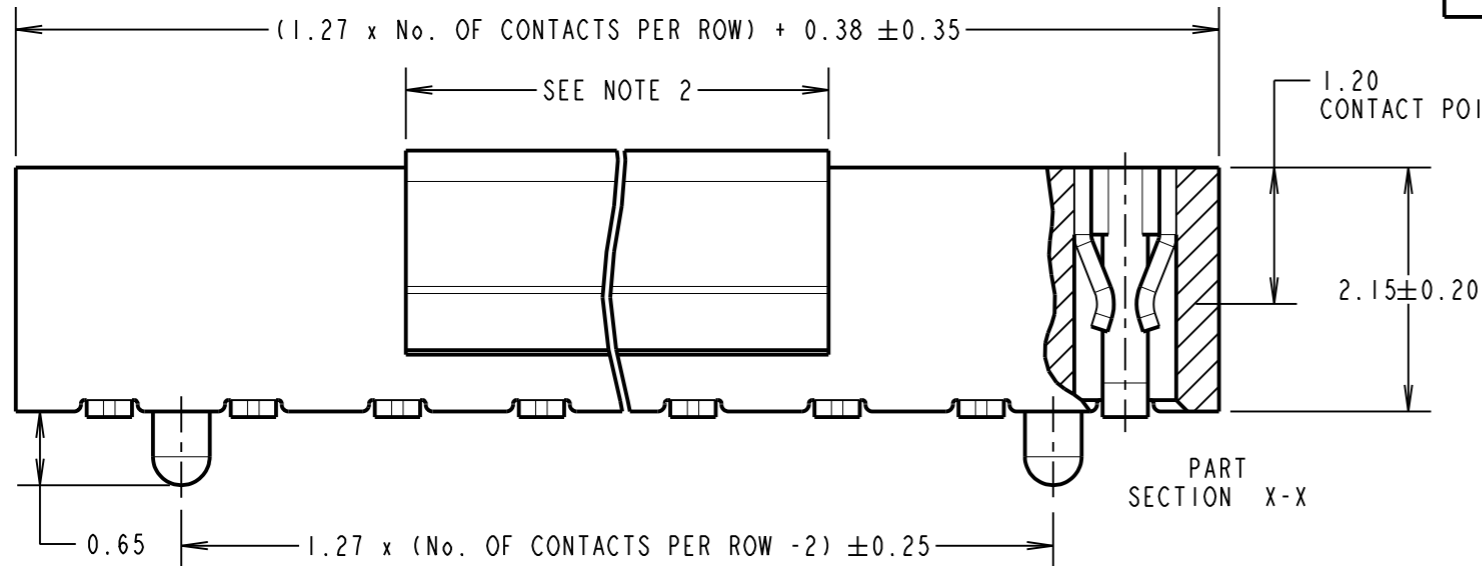

NOTE:
1. ALL TOLERANCES ARE ± 0.15 UNLESS OTHERWISE STATED.
2. PICK AND PLACE CAP LENGTH = 4.20mm FOR 03 TO 05 CONTACTS PER ROW, 6.90mm FOR 06 TO 40 CONTACTS PER ROW.
3. FOR TAPE AND REEL DETAILS, SEE SHEET 3.

HARWIN
www.harwin.com
technical@harwin.com

THIS DRAWING AND ANY INFORMATION OR DESCRIPTIVE MATTER SET OUT HEREON ARE CONFIDENTIAL AND COPYRIGHT PROPERTY OF THE HARWIN GROUP AND MUST NOT BE DISCLOSED, LOANED, COPIED OR USED FOR MANUFACTURING, TENDERING OR FOR ANY OTHER PURPOSE WITHOUT THEIR WRITTEN PERMISSION.

TOLERANCES
X = $\pm 1\text{mm}$
X.X = $\pm 0.25\text{mm}$
X.XX = $\pm 0.10\text{mm}$
X.XXX = $\pm 0.01\text{mm}$
ANGLES = $\pm 5^\circ$
UNLESS STATED

MATERIAL: SEE ABOVE
FINISH: SEE ABOVE
S/AREA: mm²

TITLE: 1.27mm PITCH DIL SMT VERT LOW PROFILE SOCKET ASSY (TAPE & REEL)

DRAWING NUMBER: **M50-315XX42R**

MSP	10	17.08.17	20750
NAME	ISS.	DATE	C/NOTE
APPROVED: M.PERREN			
CHECKED: M.PLESTED			
DRAWN: R.ADDE			
CUSTOMER REF.:			
ASSEMBLY DRG:			