

## Device connector, front mounting - RC-16P1N122200 - 1600540

Please be informed that the data shown in this PDF Document is generated from our Online Catalog. Please find the complete data in the user's documentation. Our General Terms of Use for Downloads are valid (<http://phoenixcontact.com/download>)

Device connector for front wall, straight, shielded: yes, Screw locking, M23, No. of pos.: 16, type of contact: Pin, Solder connection, Flat gasket, 4x Ø2,7, flange dimensions: 25 mm x 25 mm, Panel thickness min.: 1 mm

### Key Commercial Data

Packing unit	40 pc
GTIN	 4 046356 230582
GTIN	4046356230582

### Technical data

#### Data of the insulating body

Coding	N
Insertion/withdrawal cycles mechanical	50
Contact connection method	Solder connection
Type of contacts	Pin
Application	Signal
Number of positions	16
Contact diameter of power contacts	1 mm
Litz wire cross section of power contacts min.	0.08 mm <sup>2</sup>
Litz wire cross section of power contacts max.	1 mm <sup>2</sup>
Nominal current per power contact at 25°C	8 A
Nominal voltage, power contact	150 V
Rated surge voltage	1.5 kV
Overvoltage category	II
Degree of pollution	3
Overvoltage category	II
Degree of pollution	3

#### Housing data

Housing material	Metal
Flange dimensions	25 mm x 25 mm
Type of locking	Screw locking
Degree of protection (when plugged in)	IP67
Thread type	M23

# Device connector, front mounting - RC-16P1N122200 - 1600540

## Technical data

### Environmental Product Compliance

	Lead 7439-92-1
China RoHS	Environmentally Friendly Use Period = 50
	For details about hazardous substances go to tab "Downloads", Category "Manufacturer's declaration"

## Drawings

Schematic diagram

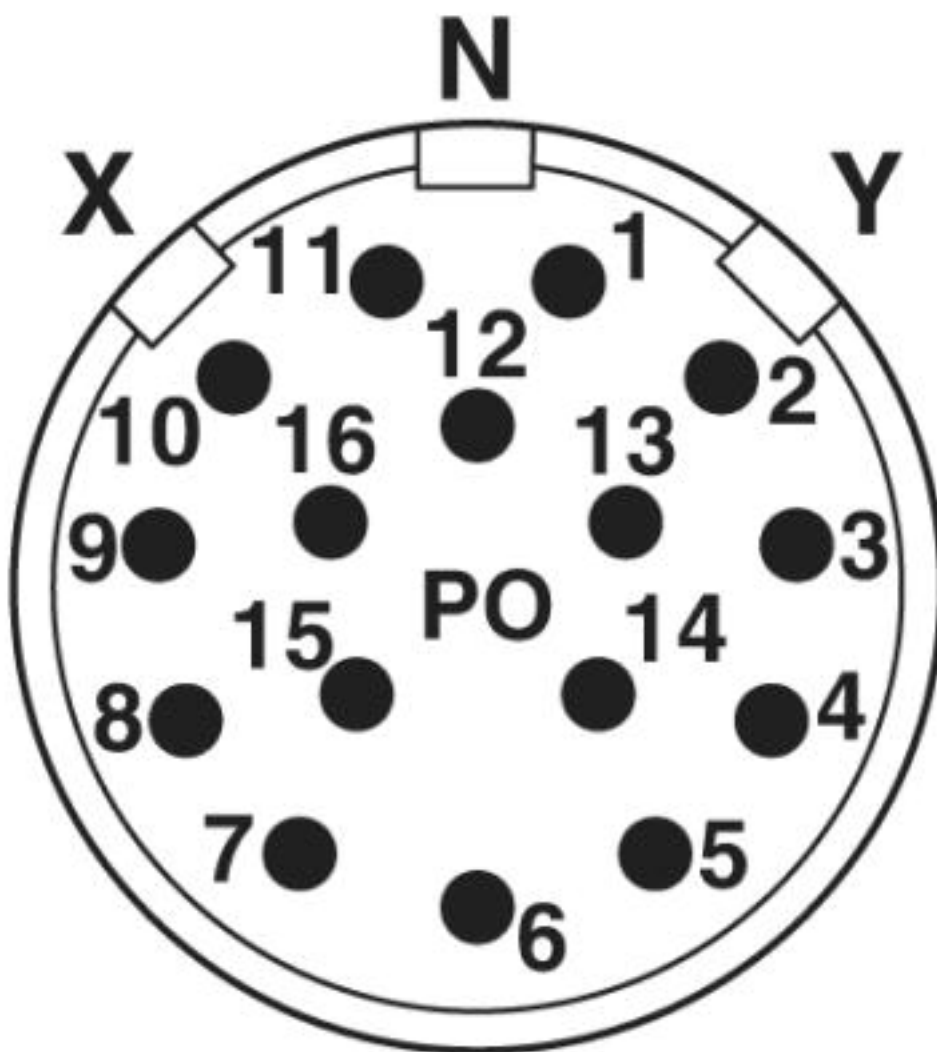

# Device connector, front mounting - RC-16P1N122200 - 1600540

Dimensional drawing

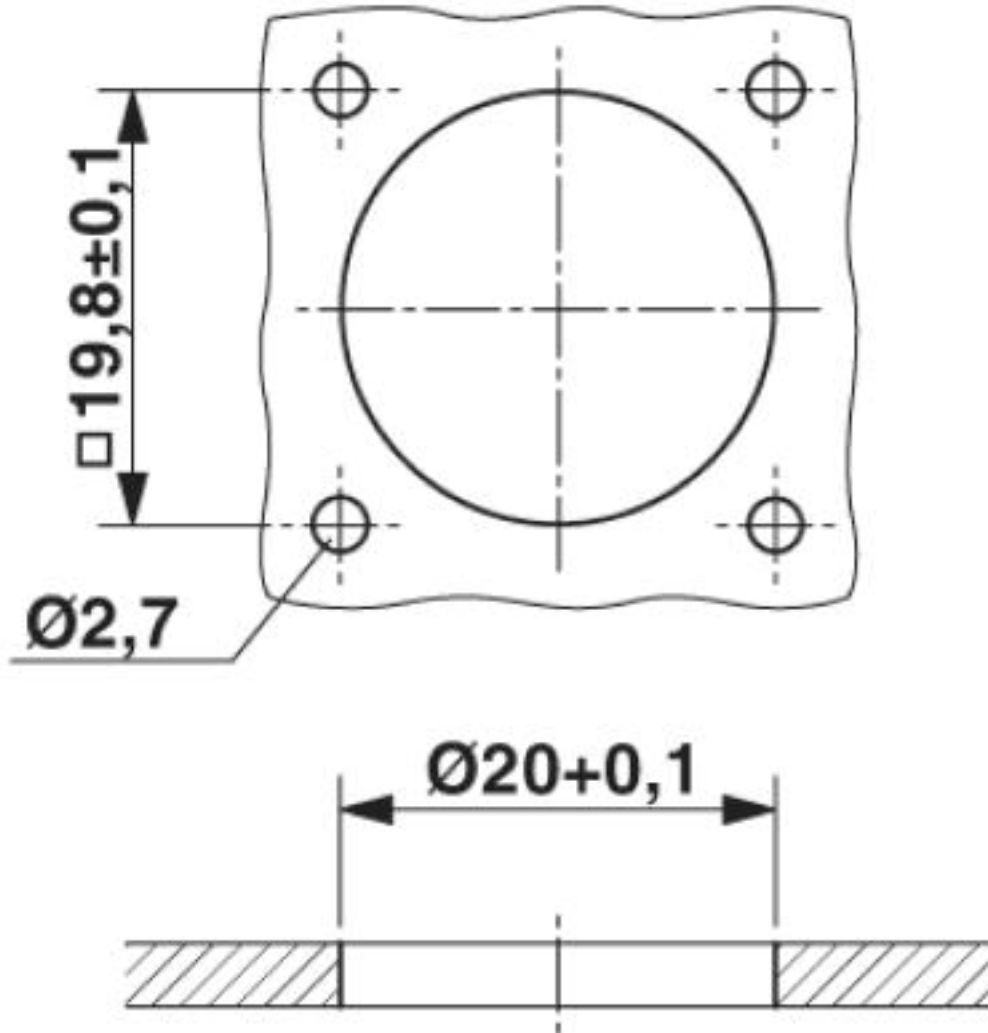

Installation dimensions  
Flat gasket

# Device connector, front mounting - RC-16P1N122200 - 1600540

Dimensional drawing

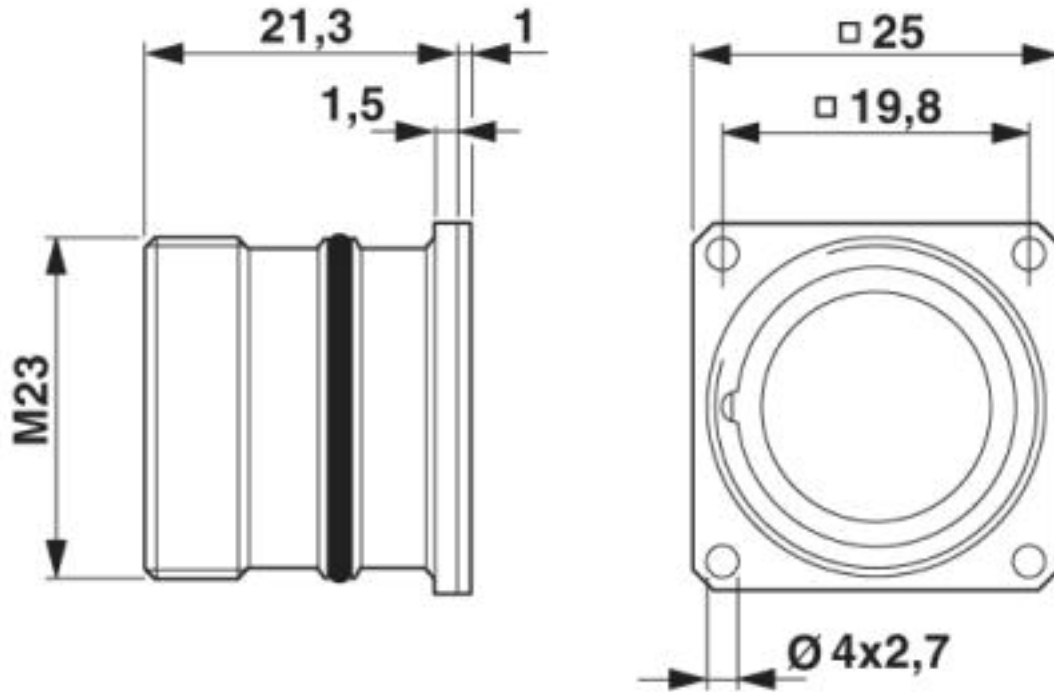

Approvals

Approvals

Approvals

EAC

Ex Approvals

Approval details

EAC		B.01742
-----	--	---------

Phoenix Contact 2019 © - all rights reserved  
<http://www.phoenixcontact.com>

PHOENIX CONTACT GmbH & Co. KG  
Flachmarktstr. 8  
32825 Blomberg  
Germany  
Tel. +49 5235 300  
Fax +49 5235 3 41200  
<http://www.phoenixcontact.com>