

PCBA: 121-60244-01  
 PCB: 600-60276-01  
 FAB DRW: 610-60265-01  
 ASSY DRW: 620-60273-01

<b>CYPRESS SEMICONDUCTOR © 2015</b>		
Title		
<b>CY8CKIT-046 PSoC 4 L-Series Pioneer Kit</b>		
Size	Document Number	Rev
A3	<b>630-60271-01</b>	<b>06</b>
Date:	Monday, October 12, 2015	Sheet 1 of 8

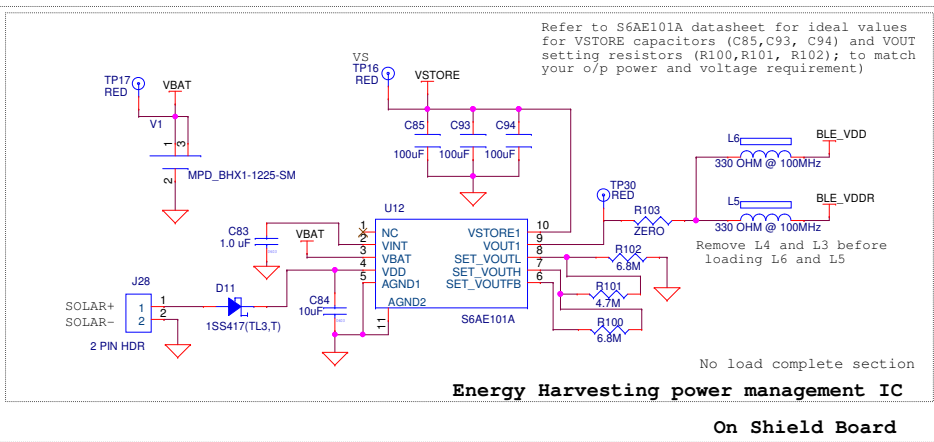
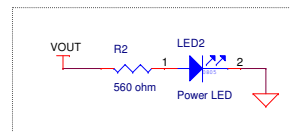
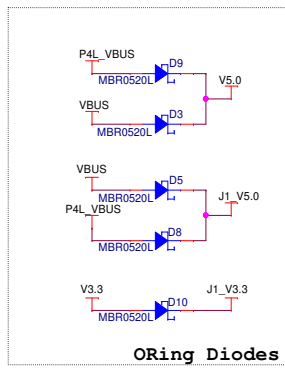
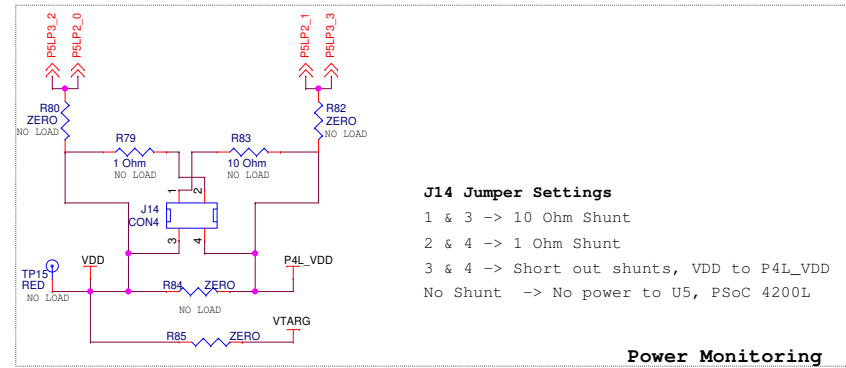
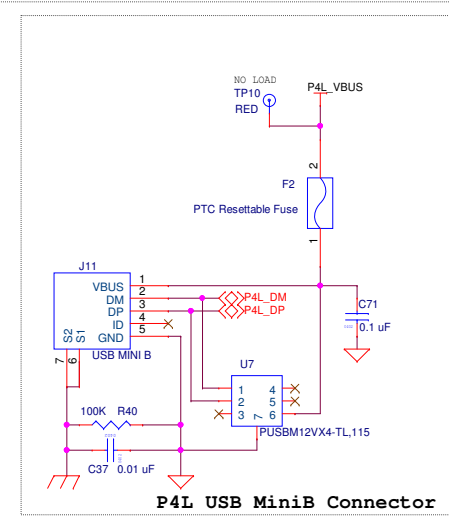
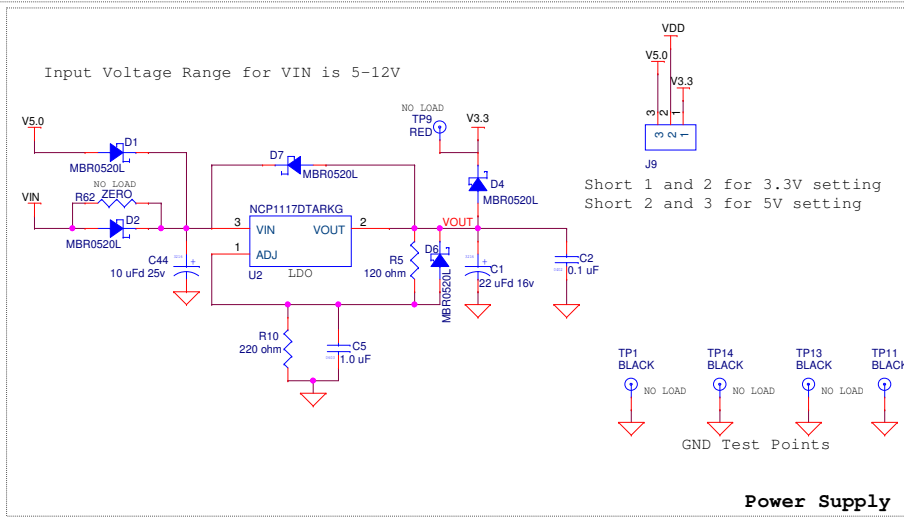
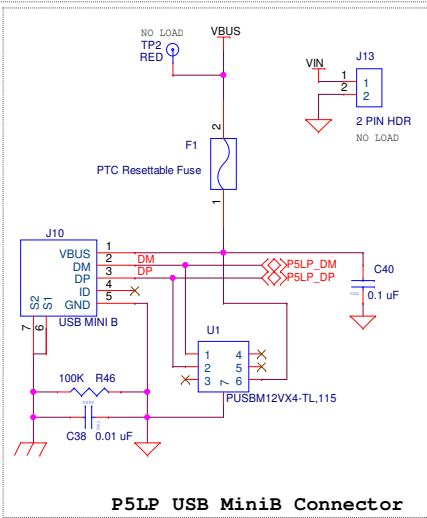

PCBA: 121-60244-01  
PCB: 600-60276-01  
FAB DRW: 610-60265-01  
ASSY DRW: 620-60273-01

<b>CYPRESS SEMICONDUCTOR © 2015</b>		
Title <b>CY8CKIT-046 PSoC 4 L-Series Pioneer Kit</b>		
Size A3	Document Number <b>630-60271-01</b>	Rev <b>06</b>
Date:	Monday, October 12, 2015	Sheet 2 of 8

# PSoc 5LP Programmer / Debugger

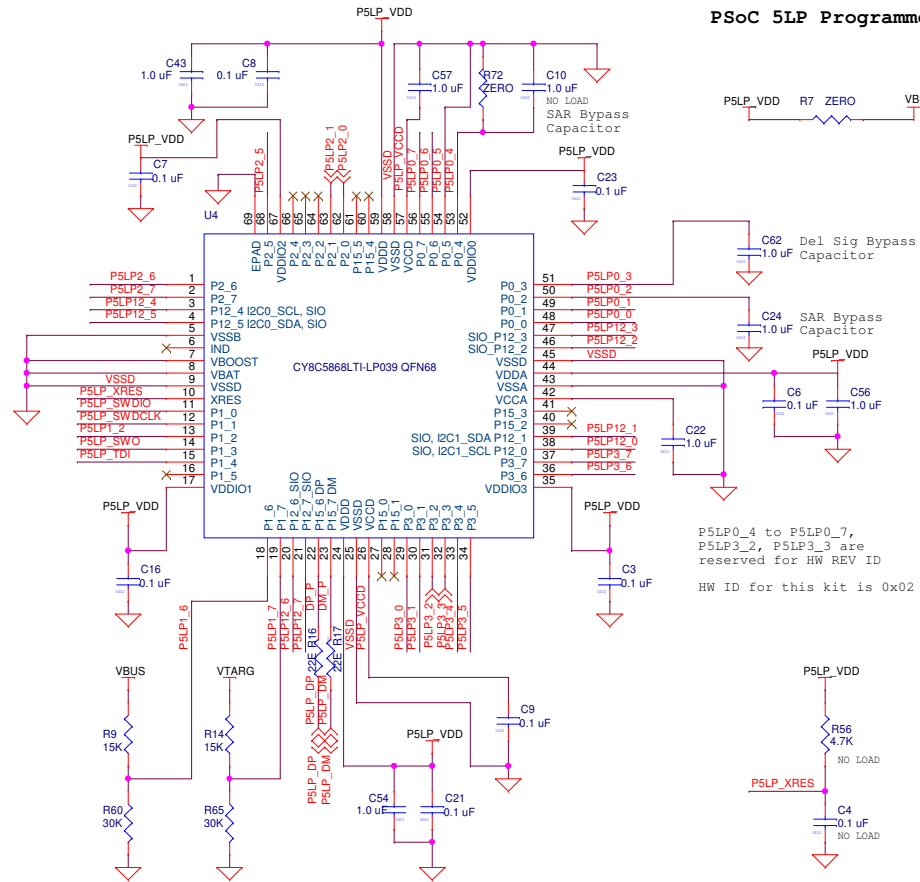

P5LP0\_4 to P5LP0\_7,  
P5LP3\_2, P5LP3\_3 are  
reserved for HW REV ID  
HW ID for this kit is 0x02

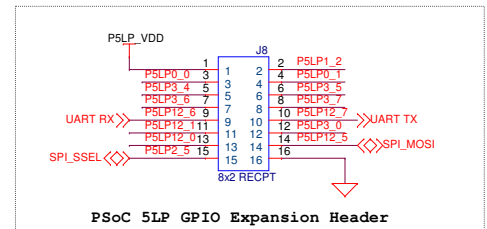
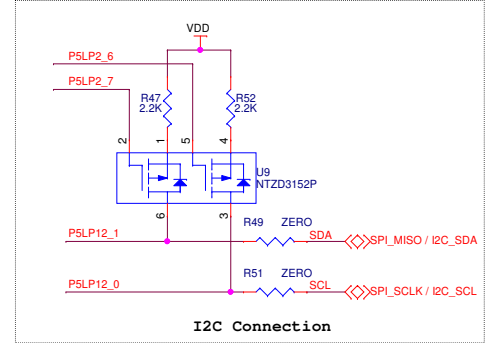
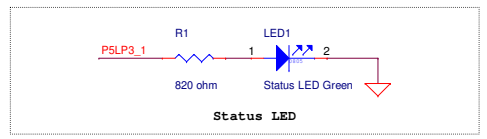

### USB-Serial Bridge Connections

P5LP12_6	-----	UART RX
P5LP12_7	-----	UART TX
P5LP12_0	-----	SPI SCLK / I2C SCL
P5LP12_1	-----	SPI MISO / I2C SDA
P5LP12_5	-----	SPI MOSI
P5LP2_5	-----	SPI SSEL

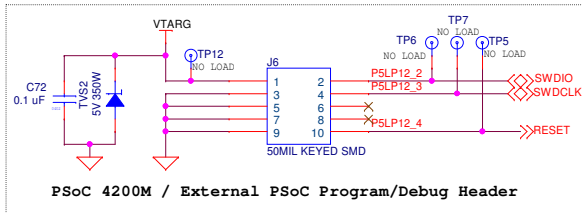
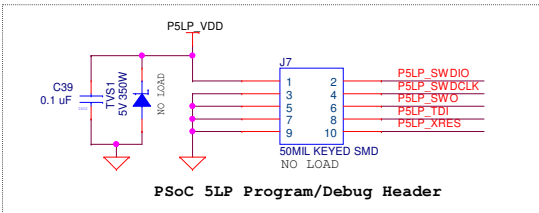

PCBA: 121-60244-01  
PCB: 600-60276-01  
FAB DRW: 610-60265-01  
ASSY DRW: 620-60273-01

CYPRESS SEMICONDUCTOR © 2015		
Title	<b>CY8CKIT-046 PSoc 4 L-Series Pioneer Kit</b>	
Size	Document Number	Rev
A3	<b>630-60271-01</b>	<b>06</b>
Date:	Monday, October 12, 2015	Sheet 3 of 8

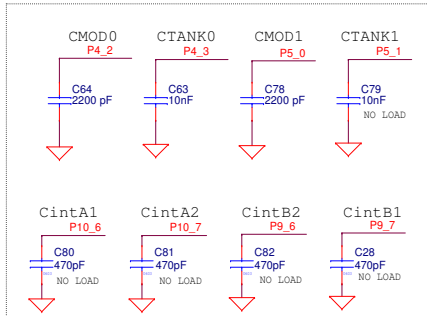

Refer kit user guide for details on Cint capacitors

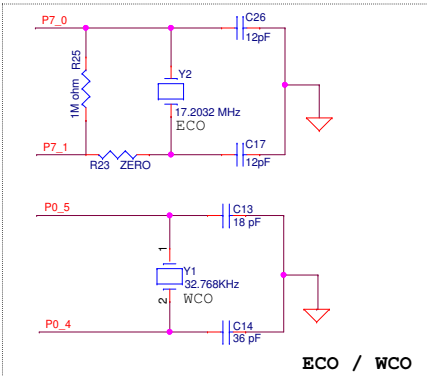

ECO / WCO

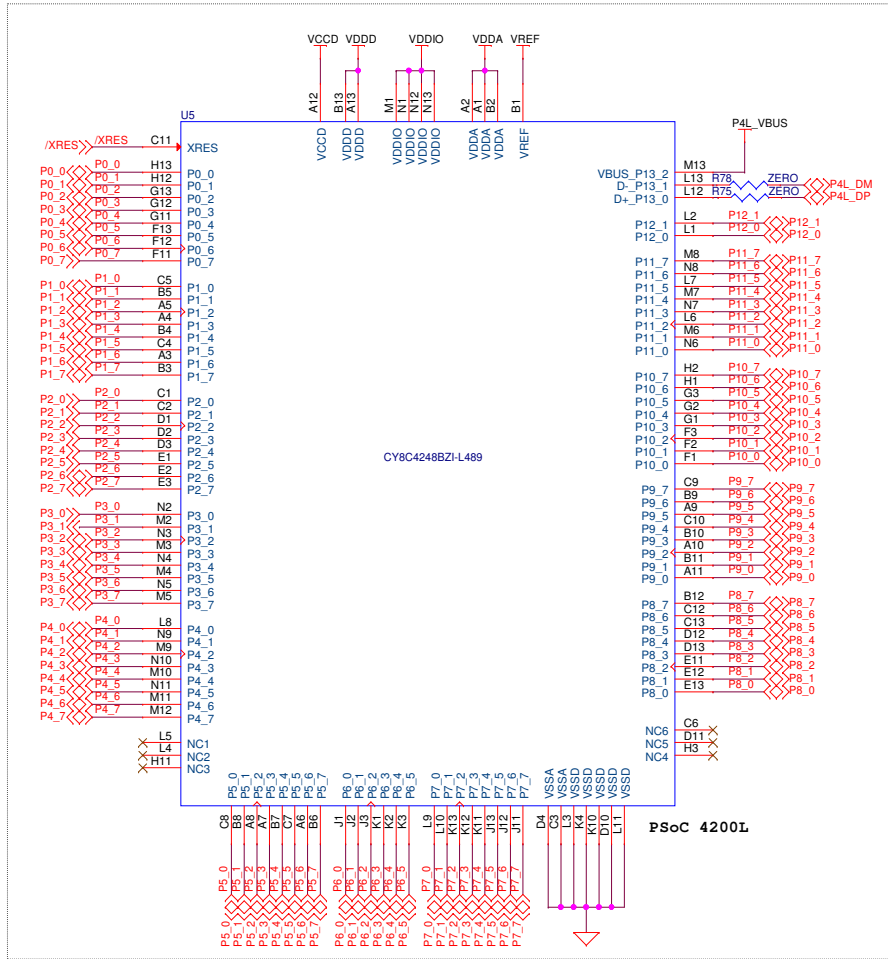

PSoc 4200L

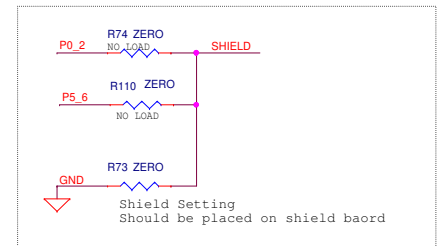
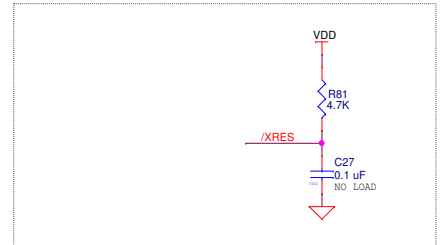
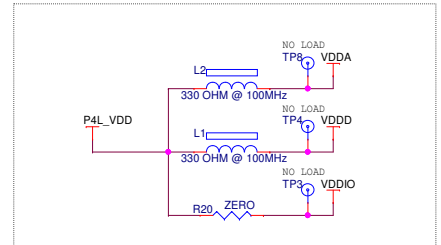

R73 is loaded by default to connect hatched pattern to GND  
 Remove R73 and load R74 to connect hatched pattern to P0\_2  
 Remove R73/ R74 and load R110 to connect hatched pattern to P0\_3 (on main board); after the shield board is snapped off

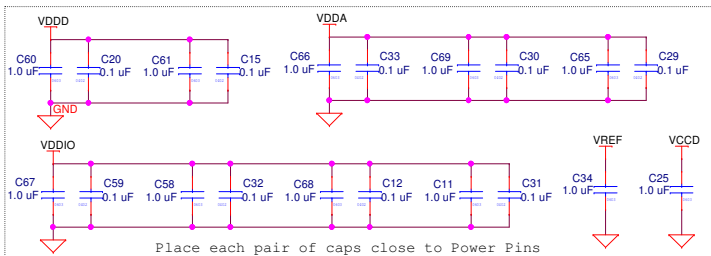

Place each pair of caps close to Power Pins

PCBA: 121-60244-01  
 PCB: 600-60276-01  
 FAB DRW: 610-60265-01  
 ASSY DRW: 620-60273-01

CYPRESS SEMICONDUCTOR © 2015			
File	CY8CKIT-046 PSoc 4 L-Series Pioneer Kit		
Size	Document Number		Rev
A3	630-60271-01		06
Date:	Monday, October 12, 2015	Sheet	4 of 8

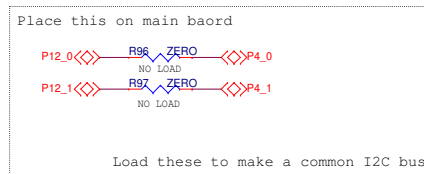
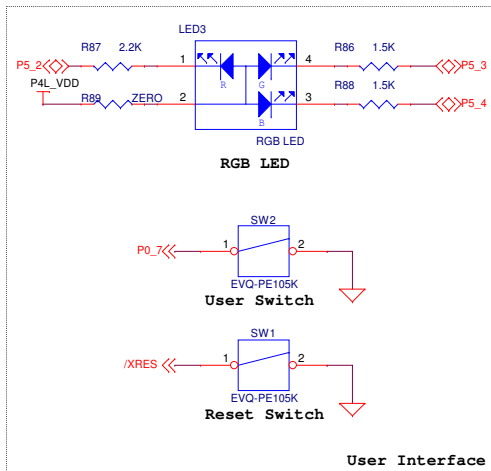
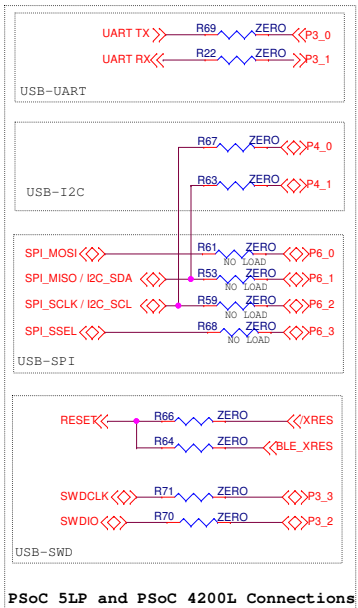
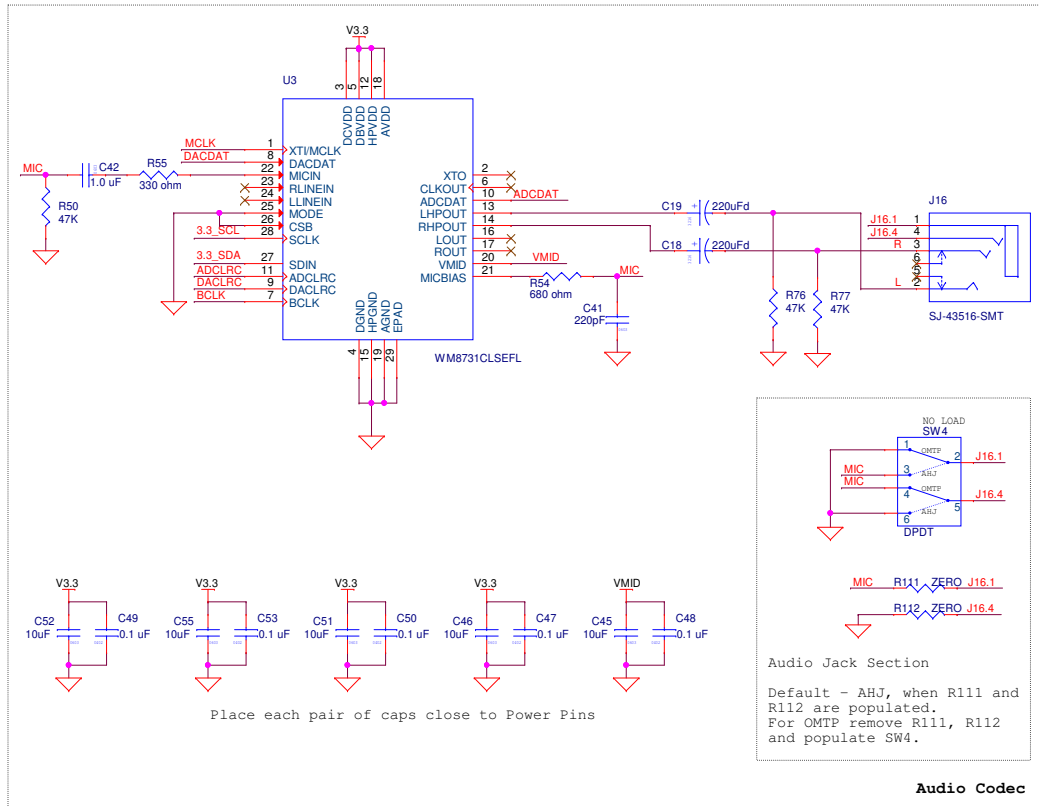
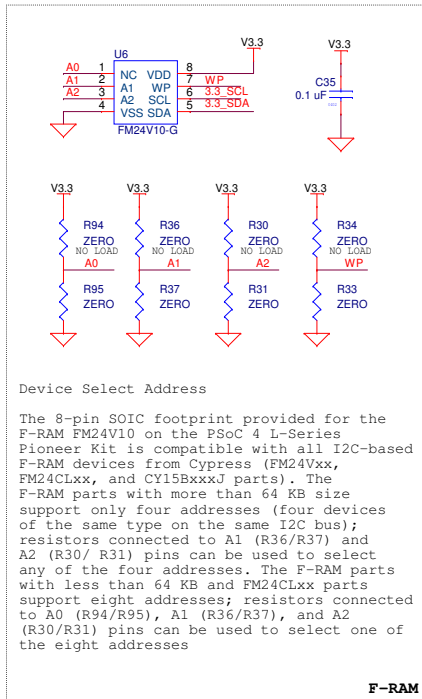
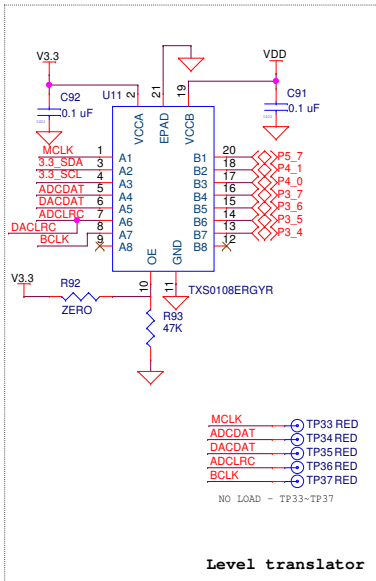

PCBA: 121-60244-01  
 PCB: 600-60276-01  
 FAB DRW: 610-60265-01  
 ASSY DRW: 620-60273-01

<b>CYPRESS SEMICONDUCTOR © 2015</b>			
Title		<b>CY8CKIT-046 PSoC 4 L-Series Pioneer Kit</b>	
Size	Document Number	Rev	
A3	630-60271-01	<b>06</b>	
Date:	Monday, October 12, 2015	Sheet	5 of 8

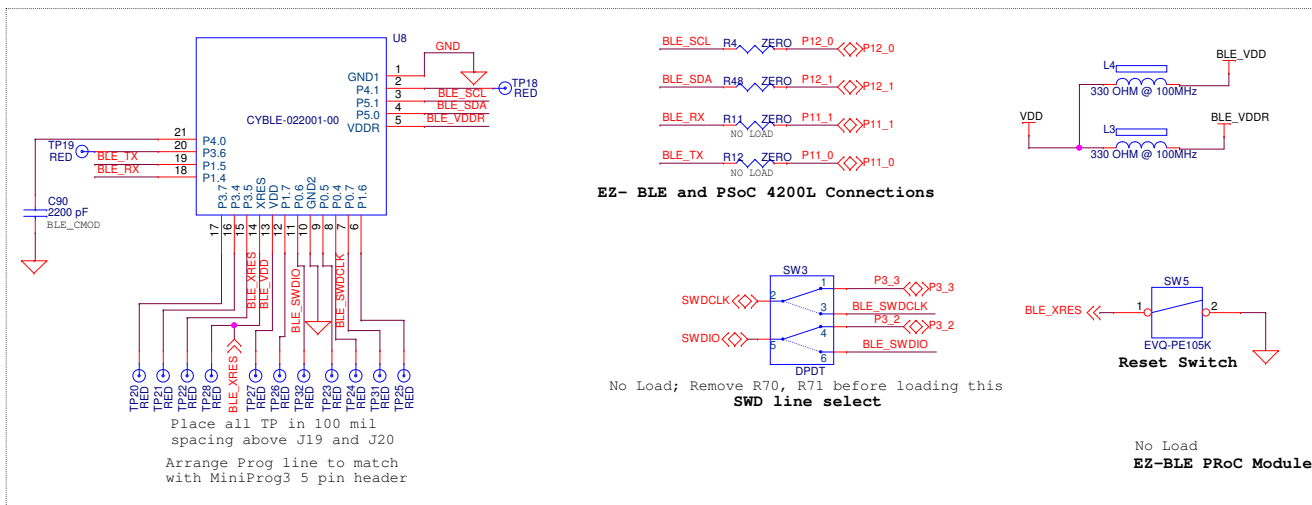
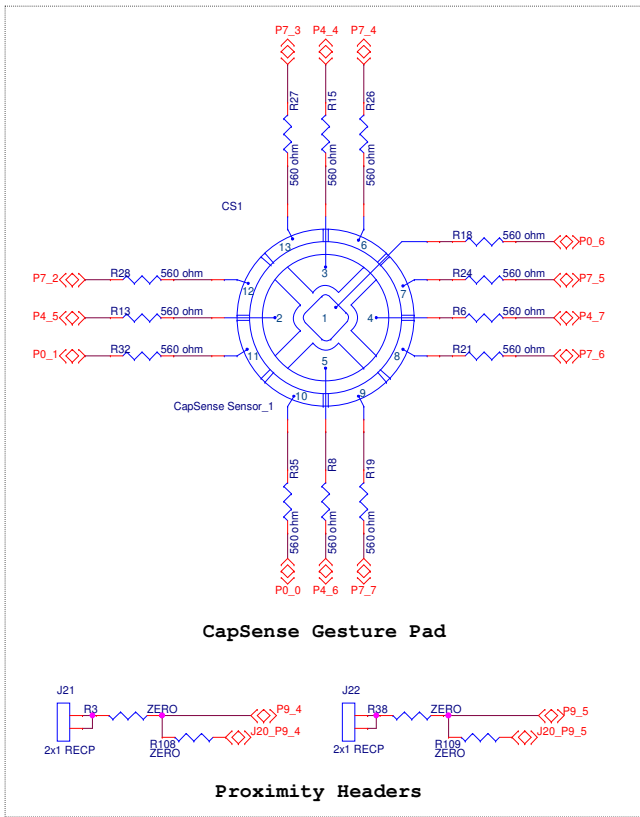
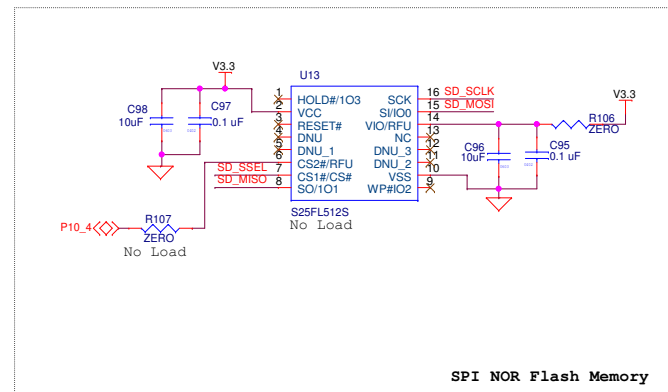
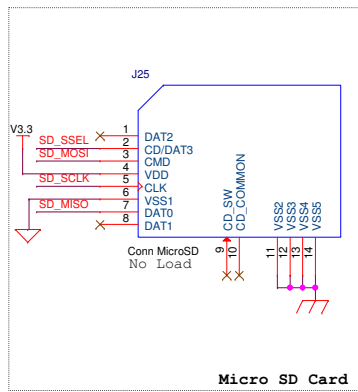
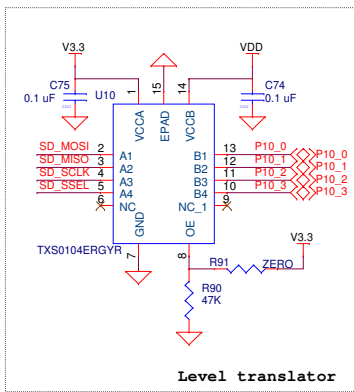
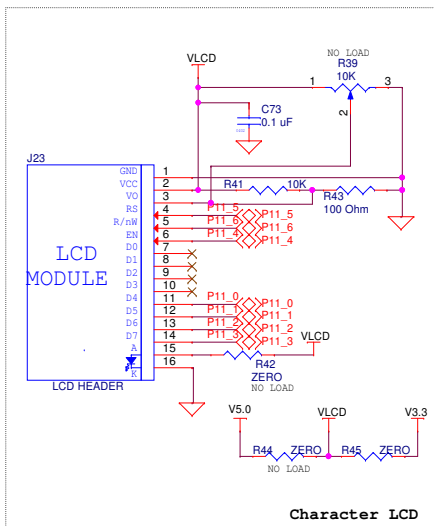

<b>CYPRESS SEMICONDUCTOR © 2015</b>		
Title	<b>CY8CKIT-046 PSoC 4 L-Series Pioneer Kit</b>	
Size	Document Number	Rev
A3	<b>630-60271-01</b>	<b>06</b>
Date:	Monday, October 12, 2015	Sheet 6 of 8

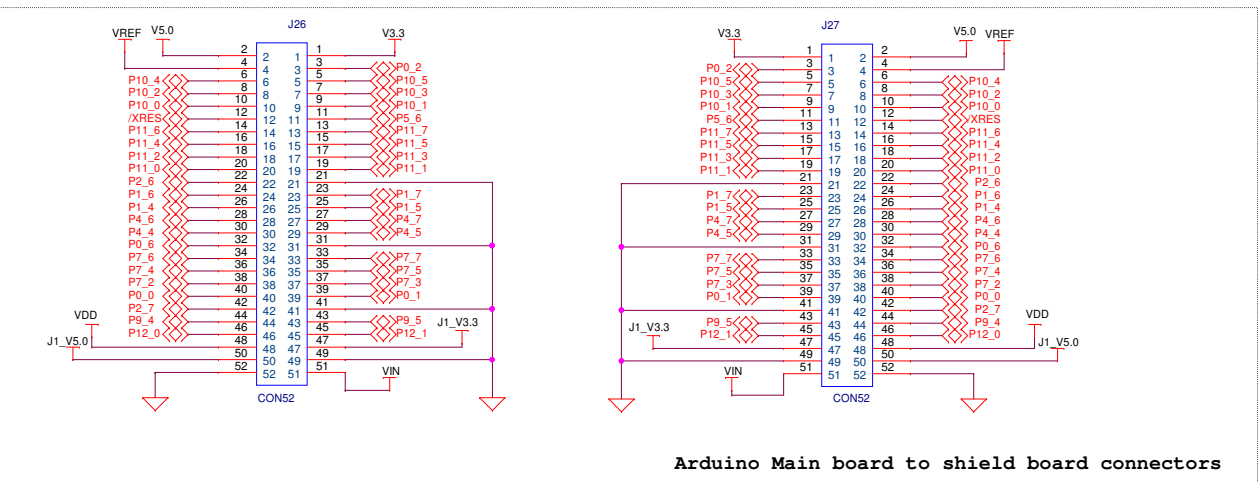
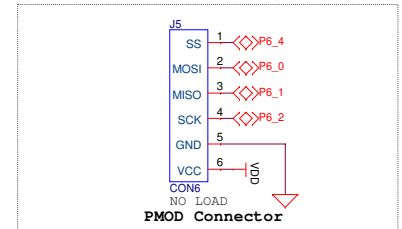
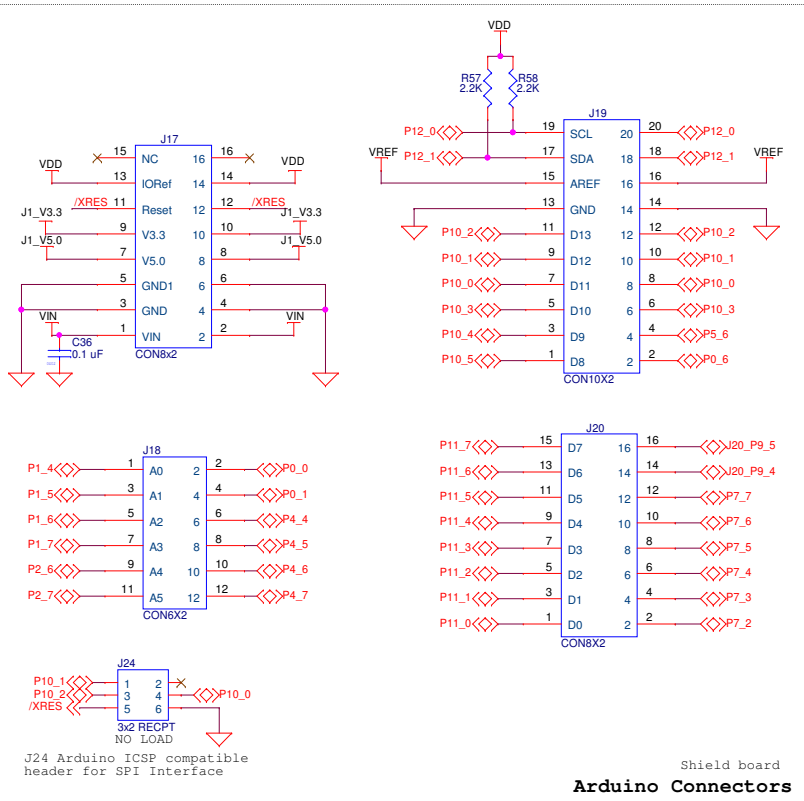
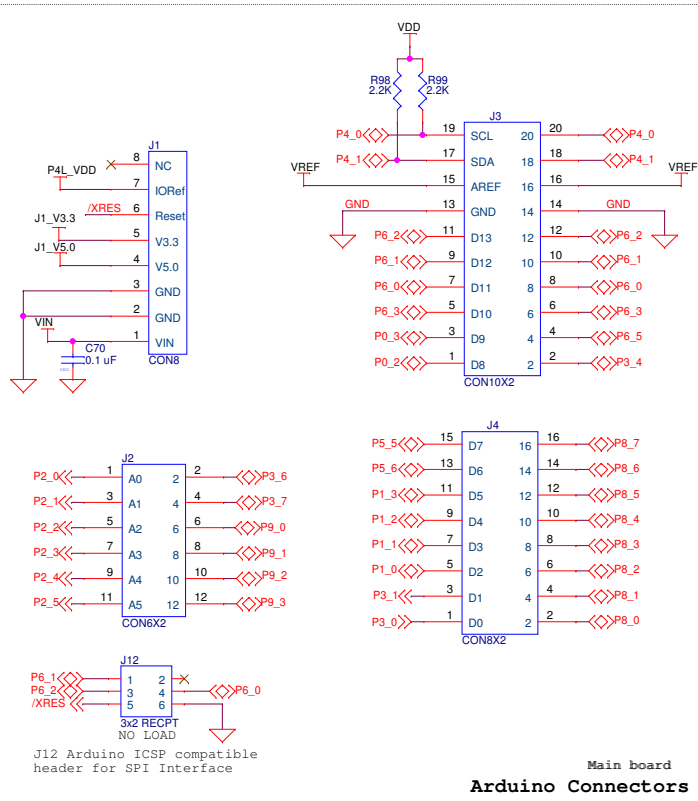

PCBA: 121-60244-01  
 PCB: 600-60276-01  
 FAB DRW: 610-60265-01  
 ASSY DRW: 620-60273-01

<b>CYPRESS SEMICONDUCTOR © 2015</b>		
Title <b>CY8CKIT-046 PSoC 4 L-Series Pioneer Kit</b>		
Size A3	Document Number <b>630-60271-01</b>	Rev <b>06</b>
Date:	Monday, October 12, 2015	Sheet 7 of 8