

PART NUMBER	REVISION	DESCRIPTION	FEED TYPE
2150154-2	C	FINE CRIMP HEIGHT ADJUST	PNEUMATIC
7-2150154-2	C	PNEUMATIC AND CRIMP TOOLING KIT	PNEUMATIC
7-2150154-7	A	CRIMP TOOLING KIT	-

ATLANTIC VERSION TERMINATOR INTERFACE ADAPTER

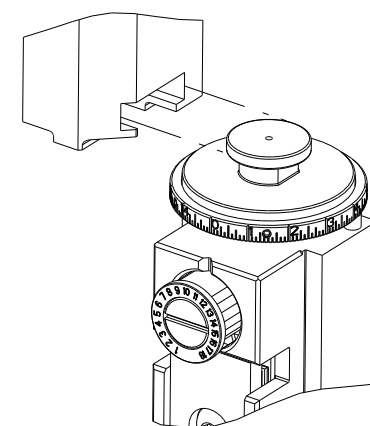

APPLICATOR DATA		
CRIMP	SIZE	TYPE
WIRE	4.06 mm [.160]	F
INSUL	6.35 mm [.250]	F
APPL INSTRUCTIONS 408-35043		

TERMINAL DATA: TE TERMINAL		TE CRIMP SPECIFICATION	
TERMINAL NAME: FASTIN-FASTON Connector 9.5mm series. TAB CONTACT			
WIRE STRIP LENGTH		INSULATION DIAMETER RANGE	
6.60-7.10 mm [.260-.280 IN]		∅3.40-5.10 mm [.134-.201 IN]	
TERMINAL APPLICATION SPECIFICATION	114-20021	-	-
TERMINALS APPLIED ³			
TE TERMINAL	TE TERMINAL	TE TERMINAL	TE TERMINAL
280075-2	280075-4		

WIRE SIZE	CRIMP HEIGHT mm [INCH]	CRIMP HEIGHT REFERENCE SETTING ⁴
6.00mm2	3.20+/-0.05 [.126+/- .002]	10.6
4.00mm2	3.00+/-0.05 [.118+/- .002]	12.6
0.75+2.50mm2	2.90+/-0.05 [.114+/- .002]	13.6

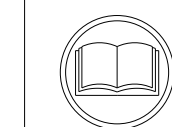

- ¹ RECOMMENDED SPARE PARTS
 - ² REFER TO SUPPLIED INSTRUCTION SHEET FOR CLEANING, LUBRICATION AND STORAGE OF APPLICATOR.
 - ³ APPLY PART NUMBER 1-23419-5 LOCTITE TO THREADS OF ITEMS 50. APPLY PART NUMBER 2-23419-6 LOCTITE TO THREADS OF ITEM 242.
 - ⁴ CRIMP HEIGHT REFERENCE SETTING WAS THE SETTING USED WHEN THE APPLICATOR WAS QUALIFIED AT THE FACTORY. ADJUSTMENT MAY BE NECESSARY WHEN RUNNING APPLICATOR IN THE FIELD.
 - ⁵ TERMINAL PITCH NOT COMPATIBLE WITH MECHANICAL FEED.
 - ⁶ CUT TO LENGTH AT ASSEMBLY.
7. UNLESS SPECIFIED OTHERWISE TORQUE VALUES SHALL BE USED PER DOCUMENT, 101-35000.

***WARNING**
ON INSTALLATION, SET WIRE DISC TO CRIMP HEIGHT REFERENCE SETTING FOR LARGEST WIRE SIZE. CRIMP HEIGHT REFERENCE SETTINGS GREATER THAN THE VALUE SHOWN MAY CAUSE DAMAGE TO THE CRIMP TOOLING, REFER TO THE INSTRUCTION SHEET FOR PROPER SETUP AND ADJUSTMENTS.

ATLANTIC VERSION
Shown on sheets 1 of 4 & 2 of 4
(Pacific version shown on sheets 3 of 4 & 4 of 4)

LOC	DIST	REVISIONS					
A	66	P	LTN	DESCRIPTION	DATE	OWN	APVD
		1		DEVELOPMENT	22FEB2012	L.Z	S.X
		B		ECR-21-113413	10SEP2021	F.J	RK
		C		ECR-21-120088	09NOV2021	F.Z	RK

-	1	1	2119641-1	FEED CAM, AIR FEED	248	
-	1	1	2119082-9	CAM, SNAIL, INSULATION ADJUSTMENT	244	
-	1	1	2079764-1	WASHER, WAVE SPRING, CREST-TO-CREST	243	
-	1	1	2119083-1	RETAINER, INSULATION DIAL	242	
-	1	1	2844940-4	AIR FEED MODULE	238	
-	1	1	1-18028-0	WASHER, FLAT, REG M8	192	
-	1	1	6-993111-6	PIN, SLOTTED SPRING 3.0 X 14.0	177	
-	1	1	8-22280-7	SPRING, COMPRESSION	176	
-	1	1	1752353-2	GUIDE PIN,HOLDDOWN	175	
-	1	1	1901680-2	GUIDE PIN,HOLDDOWN	174	
-	REF	REF	994970-2	COUNTER, MAGNETIC	164	
-	1	1	455888-5	SPACER, CRIMPER	82	
-	1	1	1803607-4	DOCUMENTATION PACKAGE	71	
-	2	2	2-18032-2	SCR, SET, FLT PNT, M3 X 10.0	70	
-	1	1	2119740-1	TAG, IDENTIFICATION	67	
-	2	2	2168078-1	SCREW, DRIVE, RH, RoHS, 2 x .188	66	
-	1	1	1901681-3	HOLDDOWN, TERMINAL	65	
-	1	1	2168083-2	SCR, SKT HD CAP, RoHS, M4 X 8.0	60	
-	1	1	5-18022-5	SCR, HEX HD CAP, M4 X 6.0	59	
-	4	4	2168400-4	SHCS, LOW HEAD, RoHS, M4 X 8	57	
-	2	2	1-2168083-5	SCR, SKT HD CAP, RoHS, M4 X 30	56	
-	2	2	5018030-1	NUT, HEX, REG, RoHS, M3	54	
-	2	2	986965-8	NUT, LOCK, HEX, TORQUE (M4)	53	
-	1	1	1-5018030-0	NUT, HEX, REG, RoHS, M3.5	52	
-	1	1	2063961-1	FEED FINGER	51	
-	1	1	1752354-4	STANDOFF,HOLD-DOWN	50	
-	1	1	18023-9	SCR, SKT HD CAP M4 X 6.0	49	
-	1	1	2119655-5	APPLICATOR BASIC ASSEMBLY, EF	46	
-	1	1	1803517-1	RAM ASSEMBLY, EF ATLANTIC	44	
-	1	1	1803602-1	SCR, BHSC, RoHS (M8 X 25)	41	
-	8	8	1-18028-2	WASHER, FLAT, REG M4	33	
-	2	2	2168083-9	SCR, SKT HD CAP, RoHS, M4 X 20	31	
-	2	2	1-2168083-0	SCR, SKT HD CAP, RoHS, M4 X 10	29	
-	1	1	240639-1	STRIPPER (MACHINING)	27	
-	2	2	1-2168083-5	SCR, SKT HD CAP, RoHS, M4 X 30	25	
-	1	1	1752371-1	PLATE, STRIP GUIDE	24	
-	2	2	3-22281-8	SPRING, COMPRESSION	22	
-	1	1	1803292-1	DRAG	20	
-	1	1	4-1901696-4	STRIP GUIDE, REAR	19	
-	1	1	4-1901695-4	STRIP GUIDE, FRONT	18	
-	4	4	1-2079383-1	SCR, BHSC, RoHS (M6 X 12)	17	
-	1	1	7-240641-0	SPACER	16	
-	1	1	1752360-1	SPACER,HOLD-DOWN	13	
-	1	1	240644-1	PLATE, REAR SHEAR	11	
-	1	1	690482-4	PLATE, FRONT SHEAR	9	
-	1	2	1	1803000-7	ANVIL, COMBINATION, END FEED	8
-	1	1	1	1-690474-7	BLADE, SLUG	7
-	1	1	1	6-240641-8	SPACER	5
-	1	1	1	238011-2	BLOCK, CRIMPER SPACER	4
-	1	2	1	2-1633961-5	CRIMPER, INSULATION F PREMIUM	3
-	1	1	1	1-455888-7	SPACER, CRIMPER	2
-	1	2	1	456427-3	CRIMPER, WIRE	1
-	77	72	2	PART NO	DESCRIPTION	ITEM NO

DIMENSIONS:		TOLERANCES UNLESS OTHERWISE SPECIFIED:		MATERIAL:	
mm	0 PLC ±	1 PLC ±	2 PLC ±	3 PLC ±	4 PLC ±
	ANGLES ±	FINISH			
DWN L. ZHANG 16FEB2012		CHK L. ZHANG 16FEB2012		NAME S. XI 16FEB2012	
DIMENSIONING AND TOLERANCING PER ASME Y14.5M-2009		APVD S. XI 16FEB2012		PRODUCT SPEC	
MATERIAL		WEIGHT		APPLICATION SPEC	
-		-		-	
Customer Accessible Production Drawing		SCALE 1:1		SHEET 1 OF 4	

LOC	DIST	REVISIONS			
P	LTN	DESCRIPTION	DATE	OWN	APVD
A	66	SEE SHEET 1	-	-	-

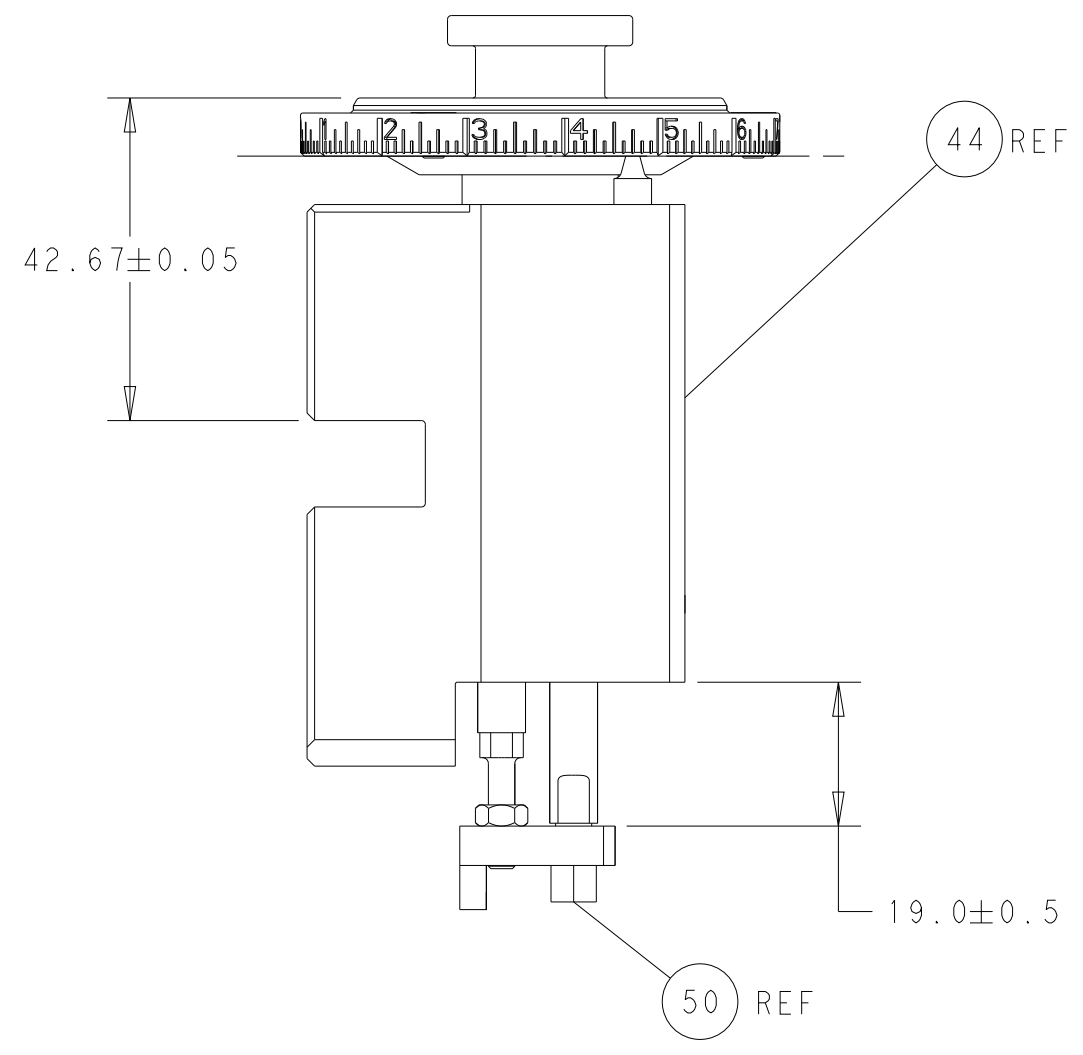

RAM AND HOLDDOWN SET-UP

FEED TYPE

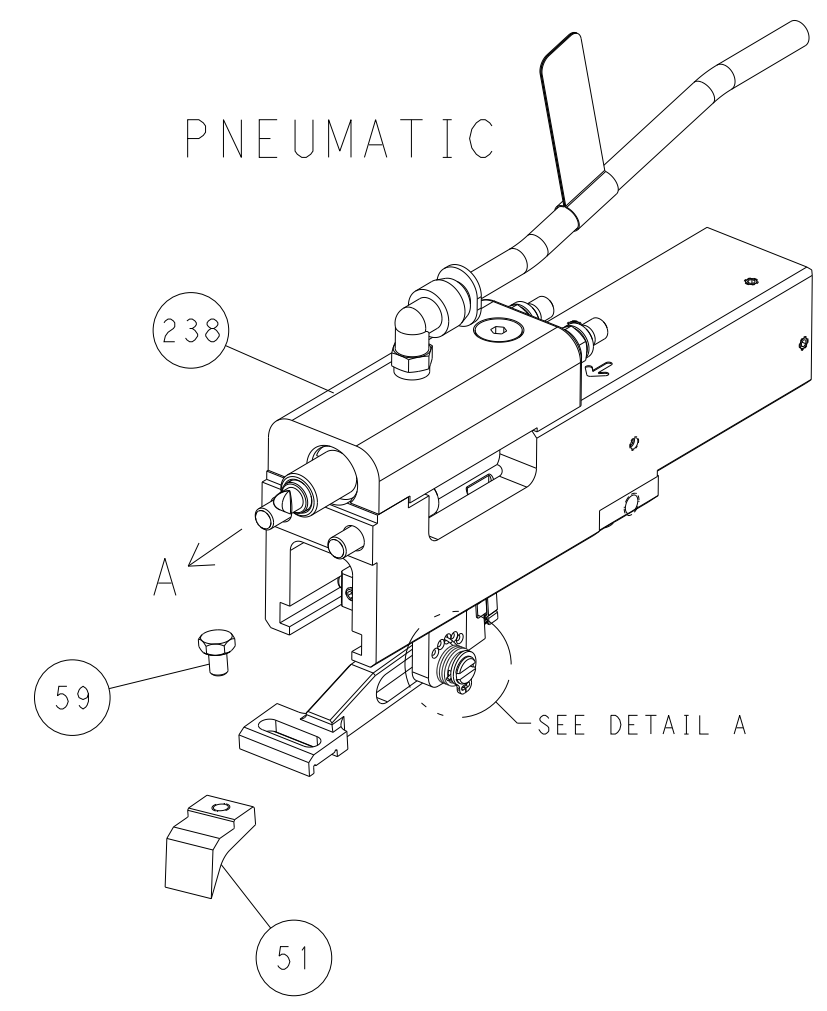

FEED SPRING SETTING POSITION

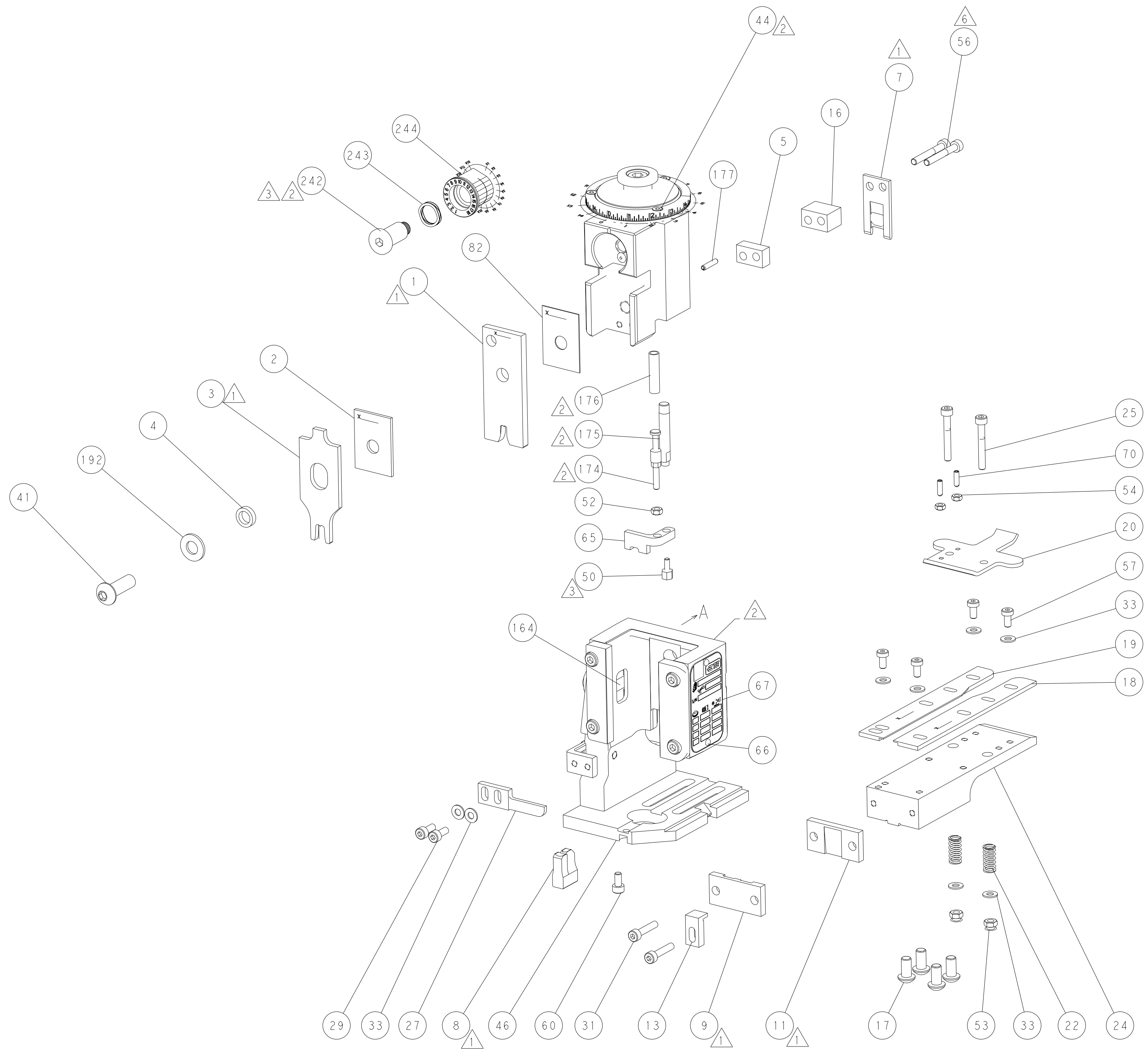
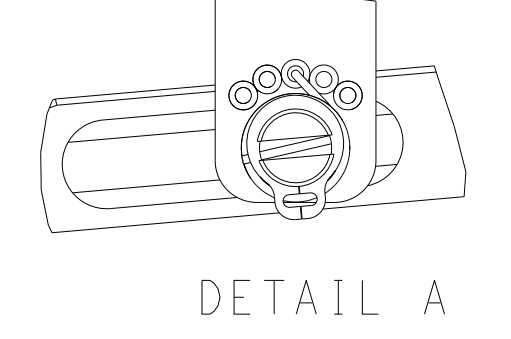

CAM POSITION

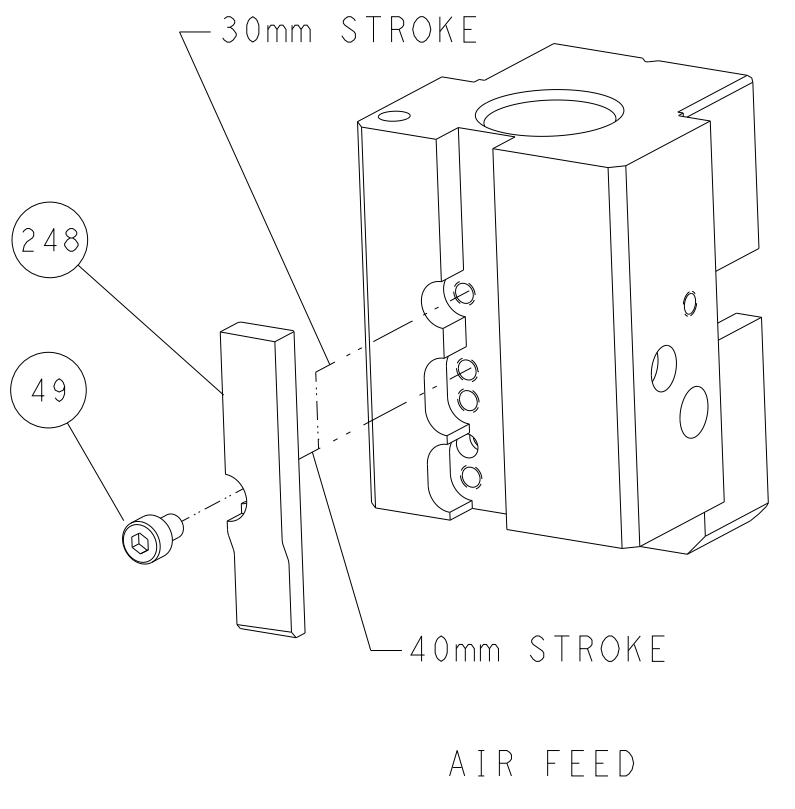

ATLANTIC VERSION
 Shown on sheets 1 of 4 & 2 of 4
 (Pacific version shown on sheets 3 of 4 & 4 of 4)

<small>THIS DRAWING IS UNPUBLISHED. RELEASED FOR PUBLICATION 20 COPYRIGHT 20 BY TYCO ELECTRONICS CORPORATION. ALL RIGHTS RESERVED.</small>		DWN L. ZHANG 16FEB2012 CHK L. ZHANG 16FEB2012 APVD S. XI 16FEB2012	NAME Ocean End Feed Applicator PRODUCT SPEC APPLICATION SPEC
DIMENSIONS: mm DIMENSIONING AND TOLERANCING PER ASME Y14.5M-2009	TOLERANCES UNLESS OTHERWISE SPECIFIED: 0 PLC ± 1 PLC ± 2 PLC ± 3 PLC ± 4 PLC ± ANGLES ± MATERIAL FINISH	SIZE CAGE CODE DRAWING NO A1 00779 C=2150154	RESTRICTED TO SCALE 1:1 SHEET 2 OF 4 REV C
CUSTOMER ACCESSIBLE PRODUCTION DRAWING		SHEETS 3 & 4 ARE NOT REQUIRED FOR ATLANTIC VERSION	

PART NUMBER	REVISION	DESCRIPTION	FEED TYPE
2-2150154-2	C	FINE CRIMP HEIGHT ADJUST	PNEUMATIC
7-2150154-7	A	CRIMP TOOLING KIT	-

PACIFIC VERSION TERMINATOR
 INTERFACE ADAPTER

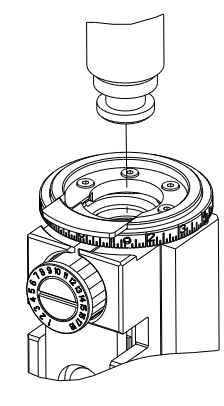

APPLICATOR DATA		
CRIMP	SIZE	TYPE
WIRE	4.06 mm [1.160]	F
INSUL	6.35 mm [1.250]	F
APPL INSTRUCTIONS 408-35043		

TERMINAL DATA: TE TERMINAL		TE CRIMP SPECIFICATION	
TERMINAL NAME: FASTIN-FASTON Connector 9.5mm series. TAB CONTACT			
WIRE STRIP LENGTH 6.60-7.10 mm [1.260-.280 IN]		INSULATION DIAMETER RANGE Ø3.40-5.10 mm [1.134-.201 IN]	
TERMINAL APPLICATION SPECIFICATION	114-20021	-	-
TERMINALS APPLIED			
TE TERMINAL	TE TERMINAL	TE TERMINAL	TE TERMINAL
280075-2	280075-4		

WIRE SIZE	CRIMP HEIGHT mm [INCH]	CRIMP HEIGHT REFERENCE SETTING
6.00mm2	3.20+/-0.05 [1.126+/-0.002]	10.6
4.00mm2	3.00+/-0.05 [1.118+/-0.002]	12.6
0.75+2.50mm2	2.90+/-0.05 [1.114+/-0.002]	13.6

- 1 RECOMMENDED SPARE PARTS
 - 2 REFER TO SUPPLIED INSTRUCTION SHEET FOR CLEANING, LUBRICATION AND STORAGE OF APPLICATOR.
 - 3 APPLY PART NUMBER 1-23419-5 LOCTITE TO THREADS OF ITEMS 50. APPLY PART NUMBER 2-23419-6 LOCTITE TO THREADS OF ITEM 242.
 - 4 CRIMP HEIGHT REFERENCE SETTING WAS THE SETTING USED WHEN THE APPLICATOR WAS QUALIFIED AT THE FACTORY. ADJUSTMENT MAY BE NECESSARY WHEN RUNNING APPLICATOR IN THE FIELD.
 - 5 TERMINAL PITCH NOT COMPATIBLE WITH MECHANICAL FEED.
 - 6 CUT TO LENGTH AT ASSEMBLY.
7. UNLESS SPECIFIED OTHERWISE TORQUE VALUES SHALL BE USED PER DOCUMENT, 101-35000.

***WARNING**
 ON INSTALLATION, SET WIRE DISC TO CRIMP HEIGHT REFERENCE SETTING FOR LARGEST WIRE SIZE. CRIMP HEIGHT REFERENCE SETTINGS GREATER THAN THE VALUE SHOWN MAY CAUSE DAMAGE TO THE CRIMP TOOLING, REFER TO THE INSTRUCTION SHEET FOR PROPER SETUP AND ADJUSTMENTS.

PACIFIC VERSION
 Shown on sheets 3 of 4 & 4 of 4
 (Atlantic version shown on sheets 1 of 4 & 2 of 4)

LOC	DIST	REVISIONS					
		P	LTN	DESCRIPTION	DATE	OWN	APVD
A	66	-	-	SEE SHEET 1	-	-	-

-	1	2119082-9	CAM, SNAIL, INSULATION ADJUSTMENT	244
-	1	2079764-1	WASHER, WAVE SPRING, CREST-TO-CREST	243
-	1	2119083-1	RETAINER, INSULATION DIAL	242
-	1	2844940-4	AIR FEED MODULE	238
-	1	1-18028-0	WASHER, FLAT, REG M8	192
-	4	2079383-9	SCR, BHSC, RoHS (M6 X 20)	186
-	1	6-993111-6	PIN, SLOTTED SPRING 3.0 X 14.0	177
-	1	8-22280-7	SPRING, COMPRESSION	176
-	1	1752353-2	GUIDE PIN,HOLDDOWN	175
-	1	1901680-2	GUIDE PIN,HOLDDOWN	174
-	REF	994970-2	COUNTER, MAGNETIC	164
-	1	2119641-2	FEED CAM, AIR FEED	152
-	1	2168083-8	SCR, SKT HD CAP, RoHS, M4 X 16	144
-	1	2119655-6	APPLICATOR BASIC ASSEMBLY, EF	141
-	1	1803518-1	RAM ASSEMBLY, EF PACIFIC	140
-	1	455888-5	SPACER, CRIMPER	82
-	1	1803607-4	DOCUMENTATION PACKAGE	71
-	2	2-18032-2	SCR, SET, FLT PNT, M3 X 10.0	70
-	1	2119740-1	TAG, IDENTIFICATION	67
-	2	2168078-1	SCREW, DRIVE, RH, RoHS, 2 x .188	66
-	1	1901681-3	HOLDDOWN, TERMINAL	65
-	1	5-18022-5	SCR, HEX HD CAP, M4 X 6.0	59
-	4	2168400-4	SHCS, LOW HEAD, RoHS, M4 X 8	57
-	2	1-2168083-5	SCR, SKT HD CAP, RoHS, M4 X 30	56
-	2	5018030-1	NUT, HEX, REG, RoHS, M3	54
-	2	986965-8	NUT, LOCK, HEX, TORQUE (M4)	53
-	1	1-5018030-0	NUT, HEX, REG, RoHS, M3.5	52
-	1	2063961-1	FEED FINGER	51
-	1	1752354-4	STANDOFF,HOLD-DOWN	50
-	1	18023-9	SCR, SKT HD CAP M4 X 6.0	49
-	1	1803602-1	SCR, BHSC, RoHS (M8 X 25)	41
-	8	1-18028-2	WASHER, FLAT, REG M4	33
-	2	2168083-9	SCR, SKT HD CAP, RoHS, M4 X 20	31
-	2	1-2168083-0	SCR, SKT HD CAP, RoHS, M4 X 10	29
-	1	240639-1	STRIPPER (MACHINING)	27
-	2	1-2168083-5	SCR, SKT HD CAP, RoHS, M4 X 30	25
-	1	1752371-1	PLATE, STRIP GUIDE	24
-	2	3-22281-8	SPRING, COMPRESSION	22
-	1	1803292-1	DRAG	20
-	1	4-1901696-4	STRIP GUIDE, REAR	19
-	1	4-1901695-4	STRIP GUIDE, FRONT	18
-	1	7-240641-0	SPACER	16
-	1	1752360-1	SPACER,HOLD-DOWN	13
-	1	240644-1	PLATE, REAR SHEAR	11
-	1	690482-4	PLATE, FRONT SHEAR	9
1	1	1803000-7	ANVIL, COMBINATION, END FEED	8
-	1	1-690474-7	BLADE, SLUG	7
-	1	6-240641-8	SPACER	5
-	1	238011-2	BLOCK, CRIMPER SPACER	4
1	1	2-1633961-5	CRIMPER, INSULATION F PREMIUM	3
-	1	1-455888-7	SPACER, CRIMPER	2
1	1	456427-3	CRIMPER, WIRE	1
-	77-22	PART NO	DESCRIPTION	ITEM NO

DIMENSIONS:		TOLERANCES UNLESS OTHERWISE SPECIFIED:		MATERIAL:	
mm	0 PLC ±	1 PLC ±	2 PLC ±	3 PLC ±	4 PLC ±
	ANGLES	FINISH			

OWN	L. ZHANG	16FEB2012
CHK	L. ZHANG	16FEB2012
APVD	S. XI	16FEB2012
NAME	Ocean End Feed Applicator	
SIZE	CAGE CODE	DRAWING NO
A1	00779	2150154
Customer Accessible Production Drawing	SCALE	1:1 SHEET 3 OF 4

LOC	DIST	REVISIONS			
P	LTH	DESCRIPTION	DATE	OWN	APVD
A	66	SEE SHEET 1	-	-	-

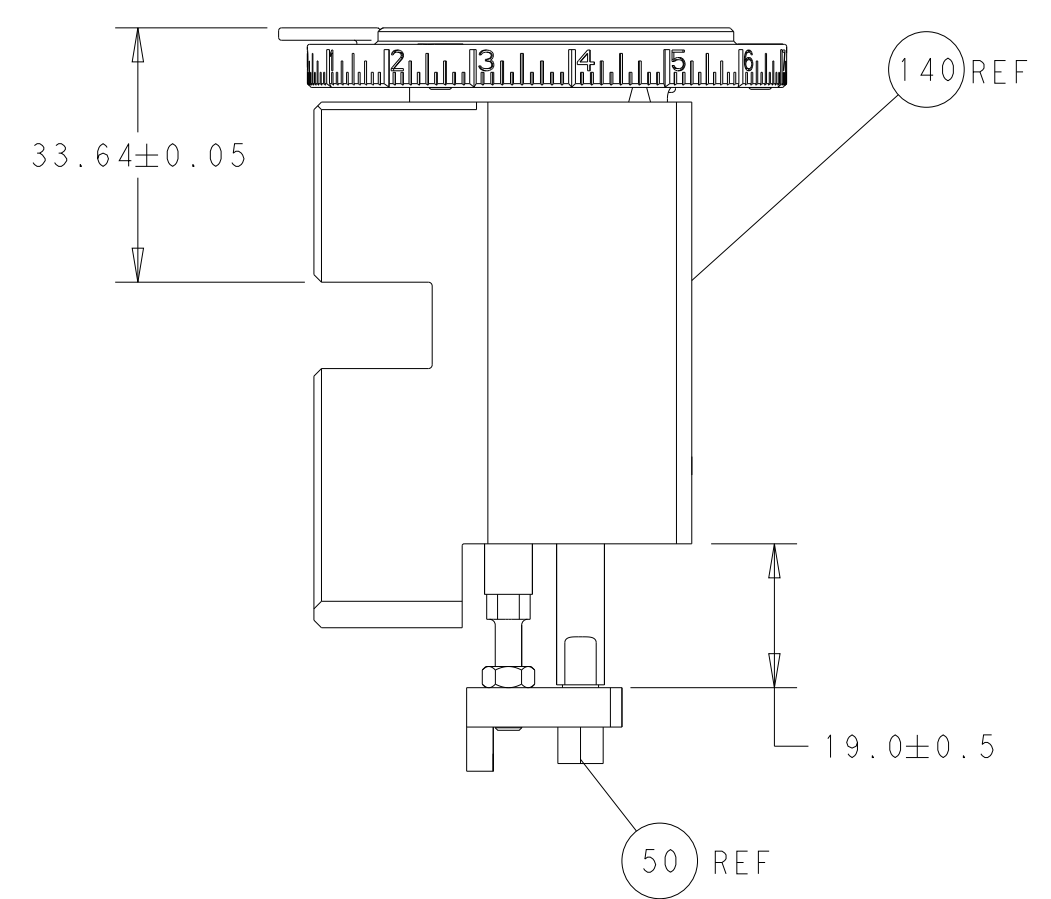

RAM AND HOLDDOWN SET-UP

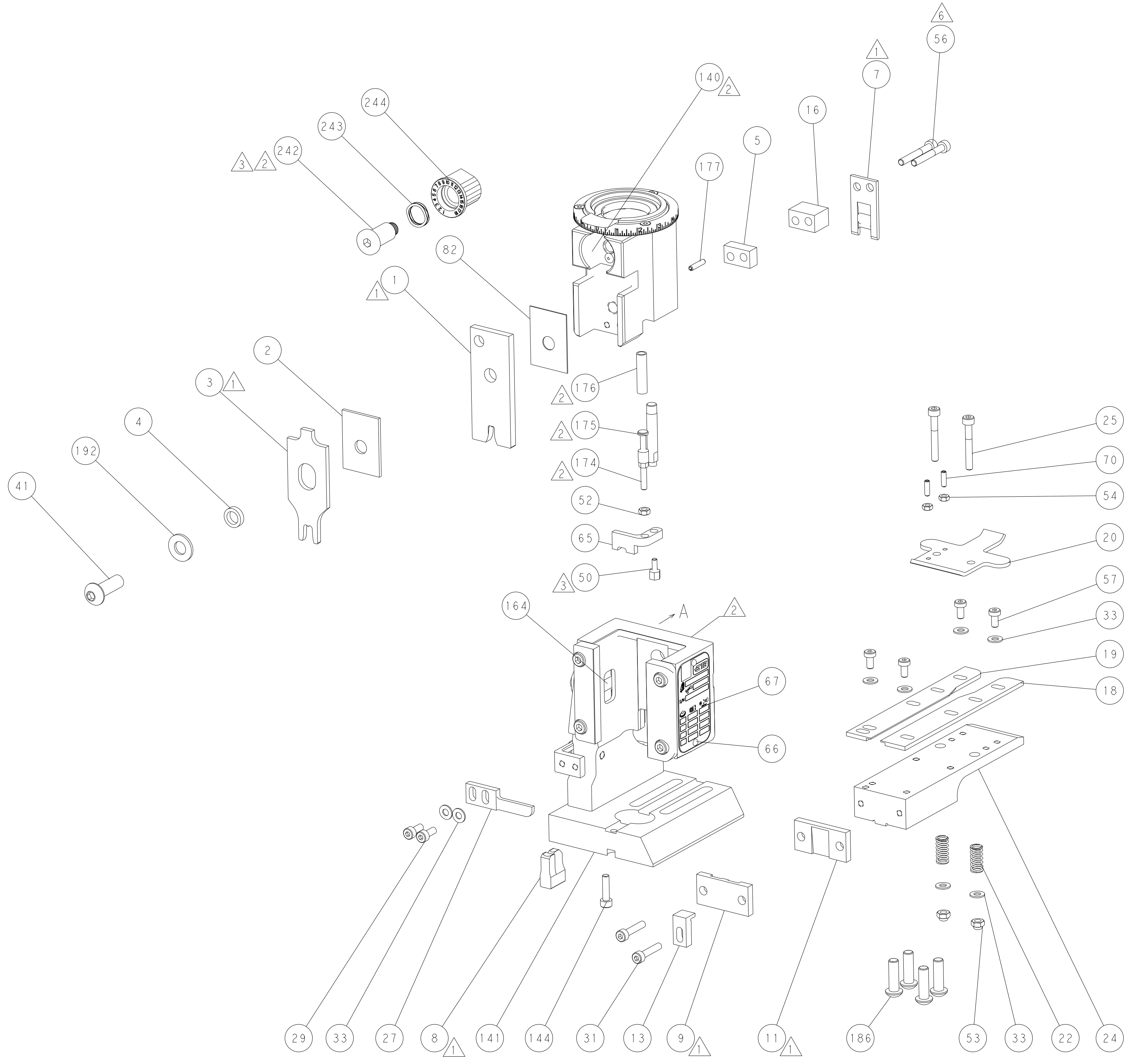

FEED TYPE

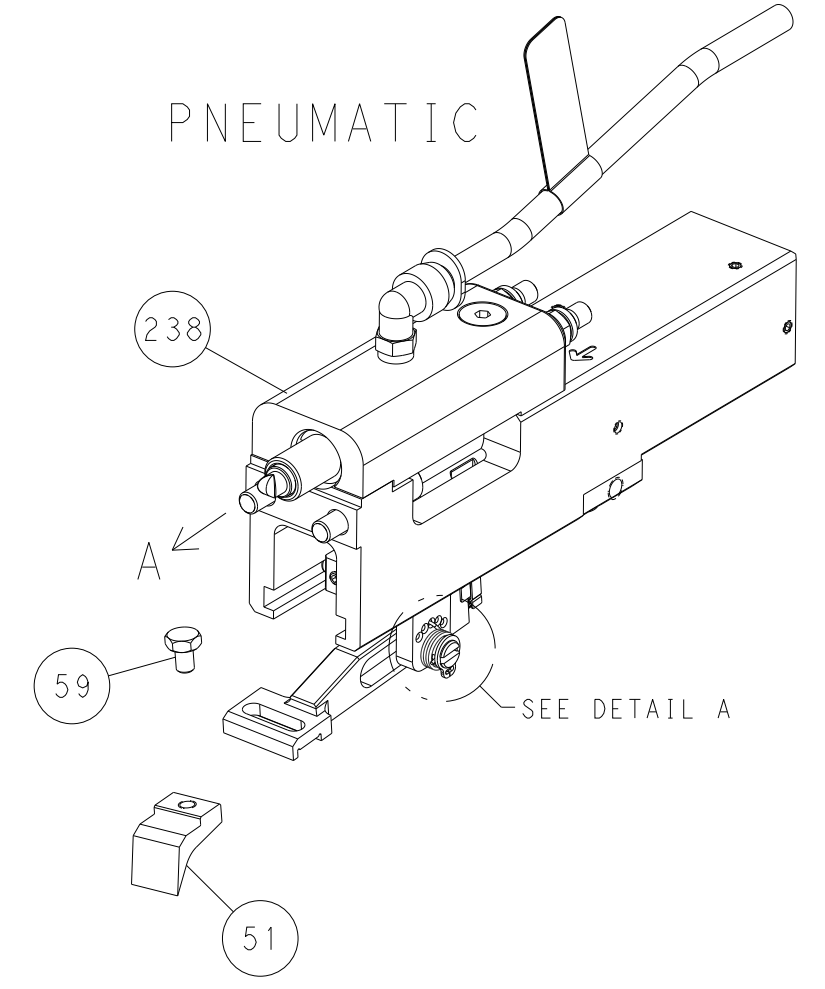

FEED SPRING SETTING POSITION

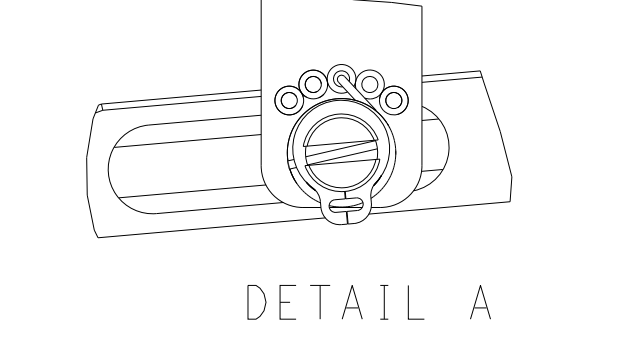

CAM POSITION

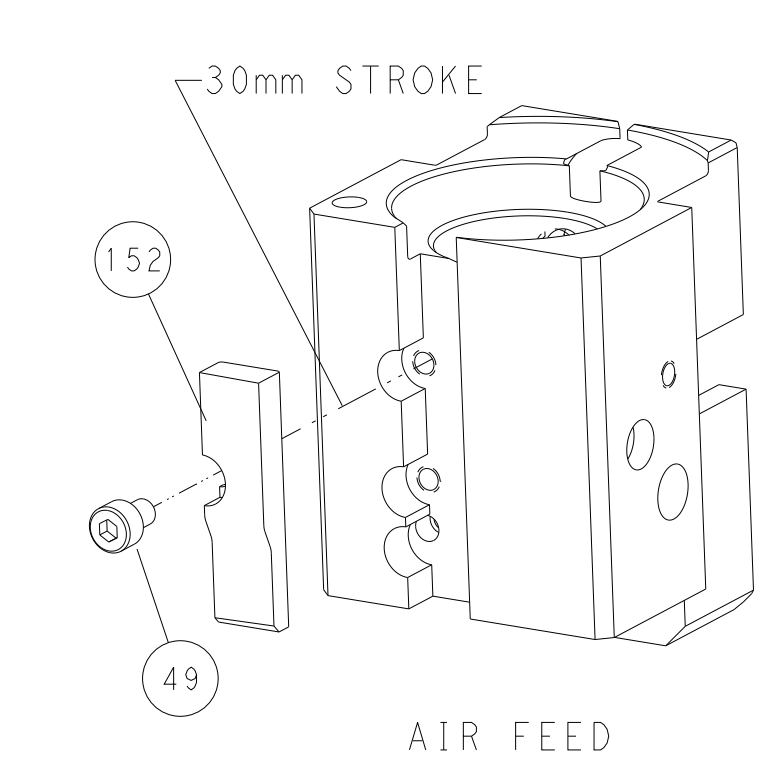

PACIFIC VERSION
 Shown on sheets 3 of 4 & 4 of 4
 (Atlantic version shown on sheets 1 of 4 & 2 of 4)

DIMENSIONS: mm DIMENSIONING AND TOLERANCING PER ASME Y14.5M-2009		TOLERANCES UNLESS OTHERWISE SPECIFIED: 0 PLC ± 1 PLC ± 2 PLC ± 3 PLC ± 4 PLC ± ANGLES ± FINISH		DWN L. ZHANG 16FEB2012 CHK L. ZHANG 16FEB2012 APVD S. XI 16FEB2012		NAME: Ocean End Feed Applicator SIZE: A1 CAGE CODE: 00779 DRAWING NO: C-2150154		RESTRICTED TO: - SCALE: 1:1 SHEET: 4 OF 4 REV: C	
MATERIAL: -				WEIGHT: -		CUSTOMER ACCESSIBLE PRODUCTION DRAWING		SCALE: 1:1 SHEET 4 OF 4 REV C	