

THIS DRAWING IS UNPUBLISHED.

RELEASED FOR PUBLICATION

ALL RIGHTS RESERVED.

© COPYRIGHT - By -

REVISIONS

| P | LTR | DESCRIPTION | DATE | DWN | APVD |
|---|----------|-------------|-----------|-----|------|
| A | CREATION | | 30-APR-18 | MT | - |

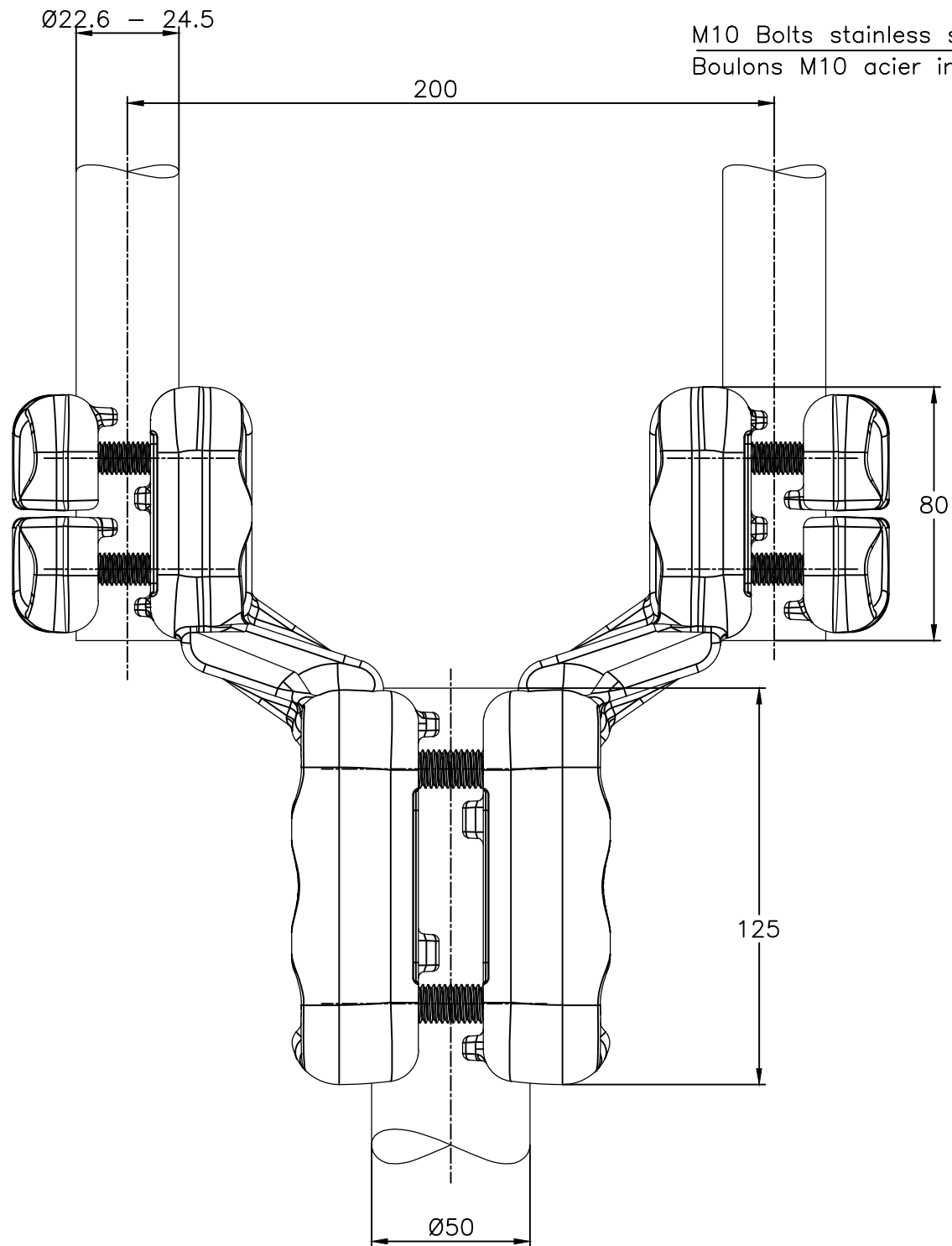

M10 Bolts stainless steel A2: 37Nm
 Boulons M10 acier inoxydable A2: 37Nm

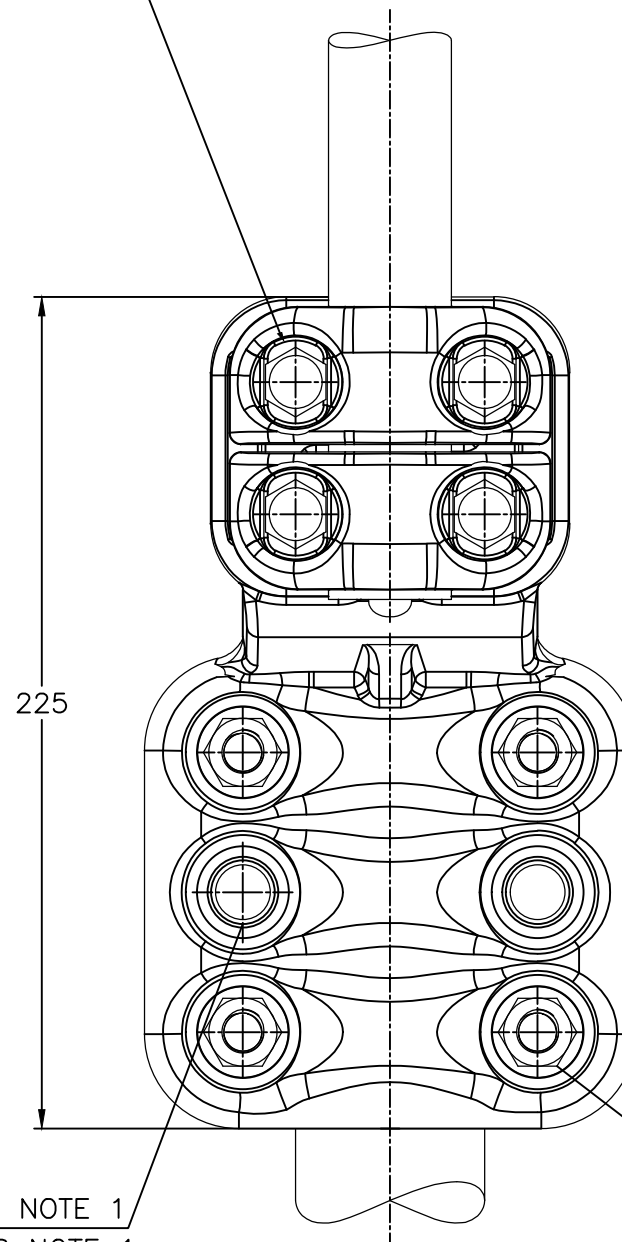

SEE NOTE 1
 VOIR NOTE 1

M12 Bolts stainless steel A2: 60Nm
 Boulons M12 acier inoxydable A2: 60Nm

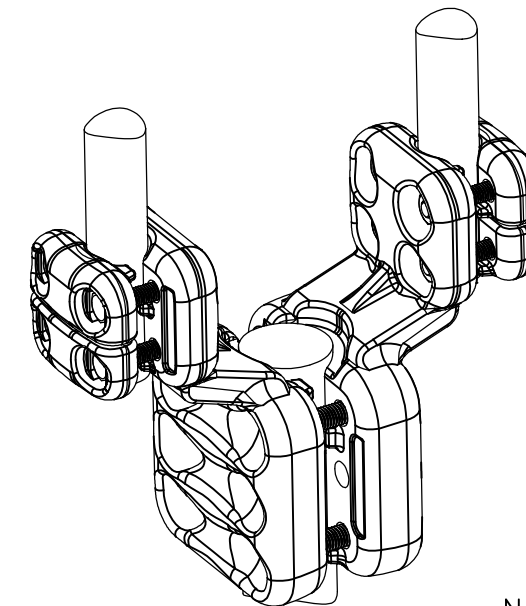

No scale
 Sans échelle

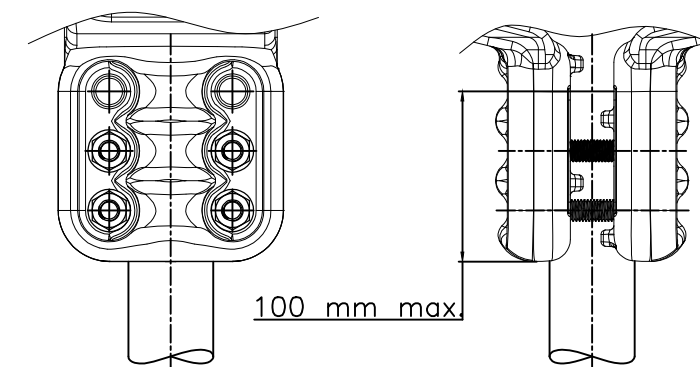

NOTE 1: Bolts Assembly for Stud length up to 100mm
 Assemblage Boulons sur Borne longueur jusqu'a 100mm

ITEM:.....

| | | | | | | | | | | | | | | | |
|--|-----|------------------|-----------|---|-----------|-------|-----|-------|-----|-------|-----|-------|-----|--------|-----|
| THIS DRAWING IS A CONTROLLED DOCUMENT. | | DWN TALPIN | 30-APR-18 |  TE Connectivity | | | | | | | | | | | |
| DIMENSIONS: mm | | CHK | - | | | | | | | | | | | | |
| TOLERANCES UNLESS OTHERWISE SPECIFIED: | | APVD | - | NAME STRAIGHT CONNECTOR TWIN TO STUD CONNECTEUR DROIT FAISCEAU DOUBLE SUR BORNE 5 CJ 82 F S245 E200 L505 | | | | | | | | | | | |
| <table border="0"> <tr><td>0 PLC</td><td>± -</td></tr> <tr><td>1 PLC</td><td>± -</td></tr> <tr><td>2 PLC</td><td>± -</td></tr> <tr><td>3 PLC</td><td>± -</td></tr> <tr><td>4 PLC</td><td>± -</td></tr> <tr><td>ANGLES</td><td>± -</td></tr> </table> | | 0 PLC | ± - | | | 1 PLC | ± - | 2 PLC | ± - | 3 PLC | ± - | 4 PLC | ± - | ANGLES | ± - |
| 0 PLC | ± - | | | | | | | | | | | | | | |
| 1 PLC | ± - | | | | | | | | | | | | | | |
| 2 PLC | ± - | | | | | | | | | | | | | | |
| 3 PLC | ± - | | | | | | | | | | | | | | |
| 4 PLC | ± - | | | | | | | | | | | | | | |
| ANGLES | ± - | | | | | | | | | | | | | | |
| MATERIAL | | APPLICATION SPEC | - | SIZE | A3 | | | | | | | | | | |
| FINISH | | APPROX.WEIGHT | 4.3 kg | CAGE CODE | 00779 | | | | | | | | | | |
| | | CUSTOMER DRAWING | | DRAWING NO | C=2332411 | | | | | | | | | | |
| | | | | RESTRICTED TO | - | | | | | | | | | | |
| | | | | SCALE | 1:2 | | | | | | | | | | |
| | | | | SHEET | 1 OF 1 | | | | | | | | | | |
| | | | | REV | A | | | | | | | | | | |