

IC0805A153R-10

PHYSICAL DIMENSIONS:

A	2.00 [.079]	+ 0.20[.008]
B	1.25 [.049]	+ 0.20[.008]
C	1.25 [.049]	+ 0.20[.008]
D	0.50 [.020]	+ 0.30[.012]

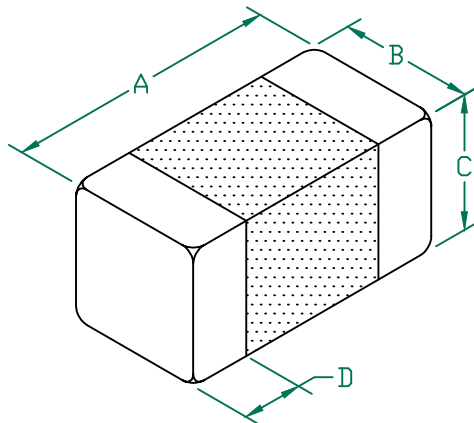

NOTES: UNLESS OTHERWISE SPECIFIED

1. TAPED AND REELED per CURRENT EIA SPECIFICATIONS 7" REELS, 3000 PCS/REEL, EMBOSSED PLASTIC TAPE.
2. TERMINATION FINISH IS 100% MATTE Sn OVER Ni.
3. COMPONENTS SHOULD BE ADEQUATELY PREHEATED BEFORE SOLDERING.
4. I (MAX.) IS BASED ON THE MAXIMUM SUSTAINED CURRENT APPLIED WHILE MAINTAINING A MAXIMUM TEMPERATURE RISE OF 40°C OVER AMBIENT.
5. OPERATING TEMP. RANGE: -40°C~+125°C. (INCLUDING SELF-HEATING)

ELECTRICAL CHARACTERISTICS:

L (nH) ± 10%	16,500	Max
	15,000	Nom
	13,500	Min
Q (Min)	30	
Freq. (MHz)	1	
Self-Resonant Freq (MHz)	19	
DCR(Max) Ω	0.80	
I (Max)	150mA	

LAND PATTERNS FOR REFLOW SOLDERING

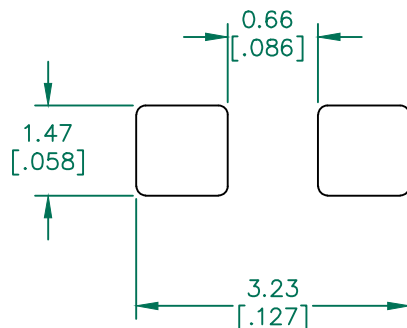

(For wave soldering, add 0.762[.030] to this dimension)

RECOMMENDED SOLDERING CONDITIONS

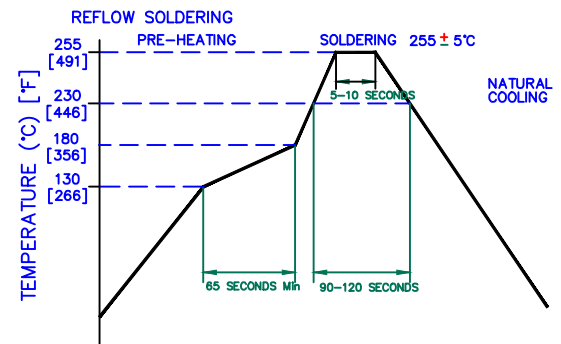

DIMENSIONS ARE IN mm [INCHES].				This print is the property of Laird Tech. and is loaned in confidence subject to return upon request and with the understanding that no copies shall be made without the written consent of Laird Tech. All rights to design or invention are reserved.			
E	REMOVE NOTE 5	07/21/16	QIU				
D	ADD OPERATING TEMPERATURE UPDATE LAIRD LOGO AND REFLOW CURVE	08/05/13	QU				
C	UPDATE COMPANY LOGO	06/18/08	JRK				
B	REMOVE K0 FROM PART NUMBER UPDATE NOTES ADD NOTES ADD ELECT. SPECS., MODIFY LP, CHG D DIMS & TOLS	01/16/07	JRK				
A	ORIGINAL DRAFT	05/06/04	JRK				
REV	DESCRIPTION	DATE	INT	PROJECT/PART NUMBER: IC0805A153R-10	REV: E	PART TYPE: CO-FIRE	DRAWN BY: JRK
				DATE: 05/06/04	SCALE: NTS	SHEET: 1 of 1	
				CAD # IC0805A153R-10-E	TOOL # -		