

All dimensions are in mm; tolerances according to ISO 2768 m-H

Cables

RTK 008 Cable group E3

Micro coax cable $d=0.81\text{mm}$, center conductor AWG36

Connector are only sold with cable.

Standard length available and customized length on request.

Picture on data sheet show an assembly example

Minimum bending radius $5x \varnothing$

Available Variants

Type	Cable	Length a [mm]	Weight [g]	Packing [pcs in plastic bag]
LE3-006-100	E3 (RTK008)	100 ± 5	tbd	25
LE3-006-110	E3 (RTK008)	110 ± 5	tbd	25
LE3-006-150	E3 (RTK008)	150 ± 5	tbd	25

Dieses Dokument ist urheberrechtlich geschützt • This document is protected by copyright • Rosenberger Hochfrequenztechnik GmbH & Co. KG

RF_35/05:10/6.0

Technical data connector 15S201-3E3

Interface

According to 15K101-40M

Documents

n.a.

Material and plating

Connector parts

	Material	Plating
Outer contact	Spring bronze	Gold, 0.15 µm
Outer contact	Spring bronze	Gold, 0.15 µm
Center conductor	Spring bronze	Gold, 0.15 µm
Dielectric	TPX blue	

Electrical data

Impedance	50 Ω
Frequency	DC to 6 GHz
Return loss	≥ 26 dB, DC to 2 GHz ≥ 23 dB, 2 to 4 GHz ≥ 20 dB, 4 to 6 GHz

Insulation resistance	≥ 0.5 x10 ³ MΩ
Center contact resistance	≤ 50 mΩ
Outer contact resistance	≤ 100 mΩ
High voltage test	200 V
Working voltage	4 V

Mechanical data

Mating cycles	≥ 100
Mating force	≤ 4 N
Unmating force	≥ 2 N
Mated height	2.4 mm

Environmental data

Temperature range	-40°C to +90°C
Storage temperature	-40°C to +90°C
RoHS	compliant

Dieses Dokument ist urheberrechtlich geschützt • This document is protected by copyright • Rosenberger Hochfrequenztechnik GmbH & Co. KG

RF_35/05:10/6.0

Cable load

Micro coax cable E3 (RTK008).
 Center conductor AWG 36
 Picture on data sheet shows an assembly example
 After mating do not apply higher forces than defined in the picture below.

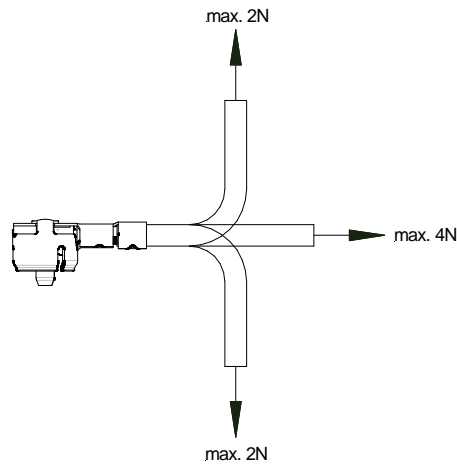

Dieses Dokument ist urheberrechtlich geschützt • This document is protected by copyright • Rosenberger Hochfrequenztechnik GmbH & Co. KG

RF_35/05:10/6.0

Mating and un-mating

For the reliable un-mating of the cable connector a special tool is dedicated:
 Un-mating tool 15W002-000

Usage remarks:

1. The vertical mating axis of the PCB receptacle and the cable connector has to be aligned during the connecting and a click will confirm that the connectors are mated correctly.
2. The disconnection of the 2 connectors is carried out vertically with the tool 15W002-000 in the mating axis of the 2 connectors.
3. The connectors should not be mated under an extreme angle.

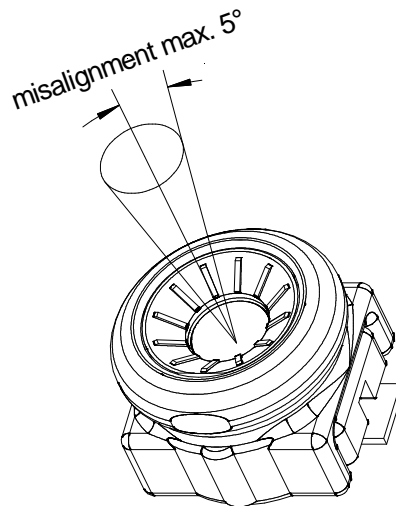

4. Avoid the forcefull twisting or deforming of the cable.

Packing

Standard 25 pcs in plastic bag
 Weight xxx g/pce (TBD)

While the information has been carefully compiled to the best of our knowledge, nothing is intended as representation or warranty on our part and no statement herein shall be construed as recommendation to infringe existing patents. In effort to improve our products, we reserve the right to make changes judged to be necessary.

Draft	Date	Approved	Date	Rev.	Engineering change number	Name	Date
F. Michelmann	11/07/12	G. Lapper	30.08.13	300	13-0961	A. Streibl	30.08.13

Rosenberger Hochfrequenztechnik GmbH & Co. KG P.O.Box 1260 D-84526 Tittmoning Germany www.rosenberger.de				Tel. : +49 8684 18-0 Fax : +49 8684 18-499 Email : info@rosenberger.de		Page 4 / 4	
--	--	--	--	---	--	---------------	--