

SW2010

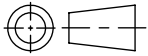

Revision level		Revision Record	Changed	Date	Approved	Date
Drawing	Part					
00	-	SEE ECN# 012160	MHT	12/02/2011	MHT	09/21/2012

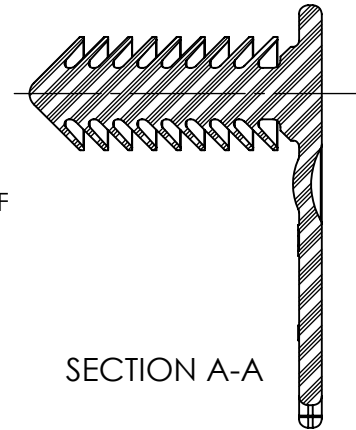
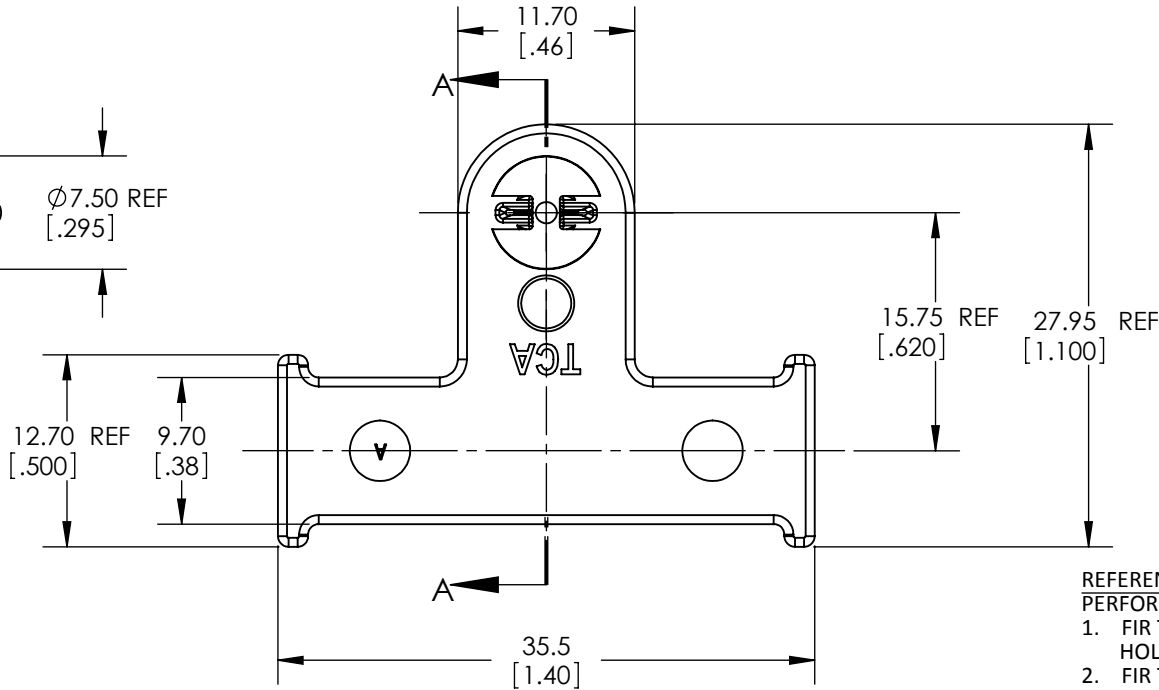
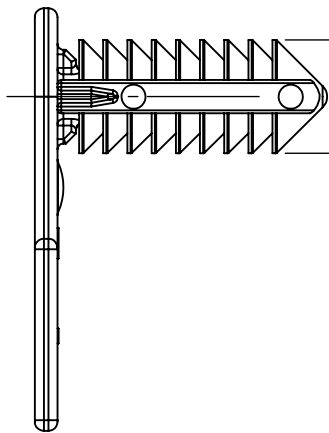
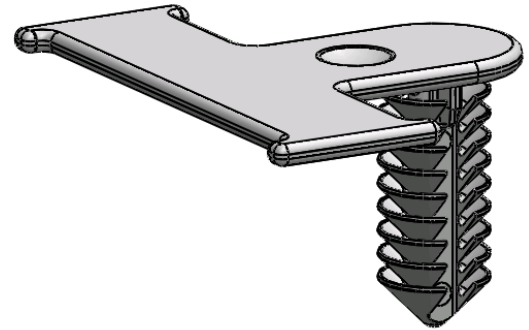
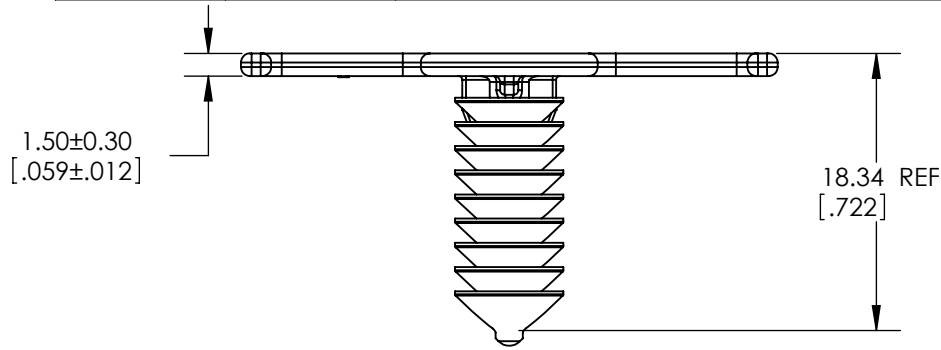

REFERENCE:

- PERFORMANCE REQUIREMENTS AT DRY AS MOLDED:
1. FIR TREE PUSH IN FORCE: 10 LBS. MAX IN A 6.5mm HOLE AND A PLATE THICKNESS OF 1.8mm
 2. FIR TREE PULL OUT FORCE: 25 LBS. MIN IN A 6.5mm HOLE AND A PLATE THICKNESS OF 1.8mm
 3. SHEET METAL THICKNESS RANGE: 0.60mm - 6.0mm
 4. HOLE SIZE: 6.5 +/-0.4

Material
PA66HIRHS NATURAL

Units millimeters

Dimension without tolerances details to:

- .xxxx = ±.127
- .xxx = ±.25
- .xx = ±.5
- .x = ±1.0
- None = ±1.5
- ∠ = ±0.5°

The copyright of this drawing is reserved by HellermannTyton. It is issued on condition that it is not reproduced, copied, or disclosed to a third party, either wholly or in part, without the consent of HellermannTyton.

Drawn	MHT	09/23/2011
Approved		
HellermannTyton North America Email: corp@htamericas.com Web: www.hellermann.tyton.com		

Article/Type-No SOC9FT6XLG

Title OFFSET BUNDLING CLIP WITH FT6XLG FIR TREE

Drawing-No 11-0586-010-CSU
Production : Phase

Scale 2:1

Project Number PRP11-0586

Format AH
Sheet 1/1