

Figure 1

## 1. INTRODUCTION

The cage assembly seating tool assemblies listed in Figure 1 are used to seat the cage assemblies listed in Figure 1 onto the pc board. The heat sink must be installed onto the cage assembly before seating. The cage assembly contains compliant pins to allow solderless pc board installation. The seating tool assembly is not designed to seat the connector.



### NOTE

Dimensions in this instruction sheet are in metric units [with U.S. customary units in brackets]. Figures are not drawn to scale.

## 2. SETUP

1. A pc board support must be used to provide proper support for the pc board and to protect the pc board and the cage assembly, heat sink, and connector from damage. Design the pc board support using the following recommendations:
  - It should be at least 25.4 mm [1 in.] longer and wider than the pc board.
  - It has flat surfaces with holes or a channel large enough and deep enough to receive any protruding components of the cage assembly
2. Power for seating tool must be provided by an application tool (with a ram) capable of supplying a downward force of 44.5 N [10 lb-force] per contact. For available application tools, call the number at the bottom of this page.



### CAUTION

Over-driving of the cage assembly will deform parts critical to the quality of the connection. Maximum force occurs prior to the cage assembly bottoming on the pc board.

3. When setting up equipment to seat the cage assembly with heat sink, pay particular attention to the following:
  - The seating tool assembly must be matched to cage assembly
  - The seating tool, cage assembly with heat sink, and application tool ram must be properly aligned before cycling the application tool.



**CAUTION**

*If the seating tool assembly and cage assembly are mismatched or are improperly aligned, damage could occur to the tooling, cage assembly with heat sink, or both.*

- The tool seating height must be set to the dimension given in Figure 2 (application tool shut height will equal the tool seating height plus the combined thicknesses of the pc board and pc board support).



**NOTE**

*After seating, a gap of no more than 0.10 mm [.004 in.] between the cage assembly standoffs and the pc board is allowed. Use the tool seating height as a reference starting point. This height may need to be adjusted to obtain the amount allowed between the standoffs of the cage assembly and the pc board.*

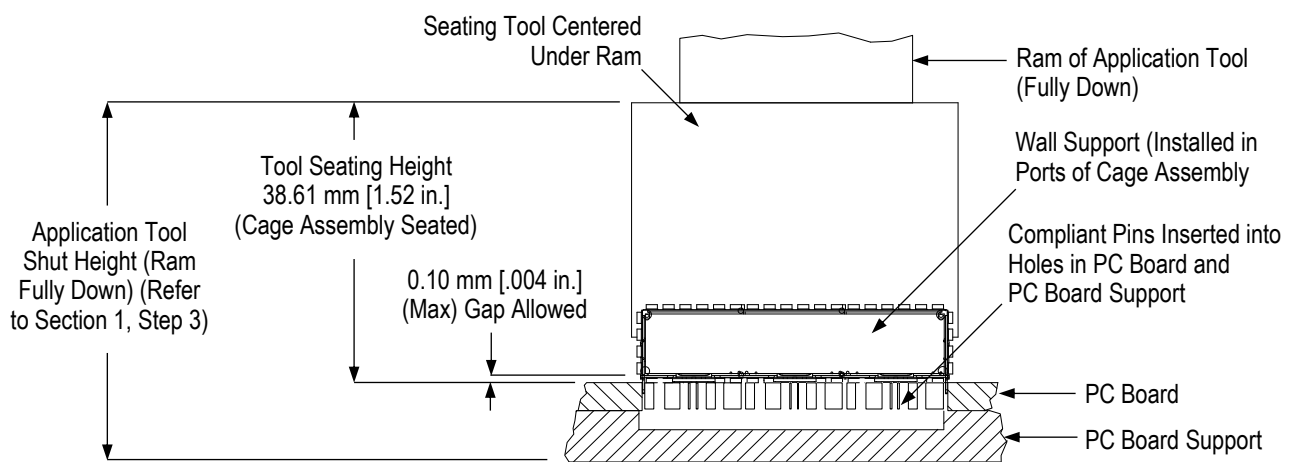

Figure 2

4. Slide the wall support into the ports of the cage assembly until it is secure (see Figure 1).

**3. SEATING** (See Figure 2)



**NOTE**

*The connector, connector cover assembly, and heat sink must be mounted on the pc board before seating the cage assembly.*

1. Place the pc board on the pc board support.
2. Orient the seating tool over the heat sink and cage assembly so that the back is aligned with the back of the cage assembly. Then lower the seating tool onto the heat sink, making sure that the cutouts slide over the protruding components of the cage assembly, until the seating tool bottoms on the top of the heat sink.
3. Place the cage assembly (with wall support and heat sink) on the pc board so that the compliant pins are aligned and started into the matching holes in the pc board.
4. Center the seating tool (with the cage assembly with wall support and heat sink) under the ram of the application tool. Slowly lower the ram until it just meets the seating tool. Verify alignment of pc board, pc board support, cage assembly with heat sink, and seating tool.



**CAUTION**

*Damage to the pc board, seating tool assembly, cage assembly with heat sink may occur if the seating tool is not properly seated on the heat sink before cycling the application tool.*

5. Cycle the application tool to seat the cage assembly with heat sink on the pc board. Then retract the ram, and carefully remove the seating tool by pulling it straight from the cage assembly with heat sink.
6. Remove the wall support from the cage assembly.
7. Check the cage assembly for proper seating according to the following:
  - The widest section of each compliant pin is inside its intended pc board hole.
  - If present, the gap between the standoffs and the pc board is not more than 0.10 mm [.004 in.]

**NOTE**

*For detailed application requirements for the cage assembly with heat sink, refer to Application Specification [114-32146](#).*

#### 4. MAINTENANCE AND INSPECTION

1. Inspect the seating tool assembly immediately upon arrival to ensure that it has not been damaged during shipment.
2. Remove dust, moisture, and contaminants with a clean, soft brush or a lint-free cloth. Do not use objects that could damage the components.
3. When the seating tool assembly is not in use, store it in a clean, dry area.
4. Periodically inspect the seating tool assembly for damage.

#### 5. REVISION SUMMARY

- Added Seating Tool Assembly 2215078-4 To Figure 1.
- Deleted Figure 3 and references to it from paragraph 4.1.