

# Channel ACTION ALERT!



**NO: TC-044**

**PRODUCT: E5AK/E5EK/E5CK Process Cont.**

**DATE: June 2011**

**TYPE: Discontinuation Update**

## E5AK/E5EK/E5CK Process Controllers Discontinued Immediately, Replace with E5\_N-H/E5\_N-HT Series

There are modifications in portions of product discontinuation notice TC-042 May issue. Changes marked in **RED** were made to the following sections:

- Discontinuation date: **Effective immediately**
- Caution on recommended replacement
- Difference from discontinued product
- Product Discontinuation and recommended replacement
- Output Specifications of E5ER-DRT in Recommended replacement.



Omron Industrial Automation will migrate to the E5\_N platform to consolidate functionality in a single product family that shares common parts.

### Cautions on Applying Recommended Replacement Models

- There is no plug-in SSR output unit for the recommended replacement. Please select the model with SSR output or drive external SSR by voltage output.
- The combination of the outputs on the DeviceNet type is limited to **two** kinds.
- SSR driving output of the replacement of E5CK is NPN. Please do not mistake wiring.

### Discontinued Products/Suggested Replacements

#### E5AK (1/4 DIN size)

Product discontinuation	Recommended replacement
E5AK-AA2 E5AK-AA2-K E5AK-AA2-500 <b>E5AK-AA2-K-500</b>	E5AN-HAA2HBM-500 AC100-240 E5AN-HAA2HHBFM-500 AC100-240
E5AK-PRR2 E5AK-PRR2-K E5AK-PRR2-500 <b>E5AK-PRR2-K-500</b>	E5AN-HPRR2BM-500 AC100-240 E5AN-HPRR2BFM-500 AC100-240
E5AK-TAA2 AC100-240 E5AK-TAA2-500 AC100-240 E5AK-TAA2-K AC100-240 E5AK-TAA2-K-500 AC100-240	E5AN-HTAA2HBM-500 AC100-240 E5AN-HTAA2HHBFM-500 AC100-240
E5AK-TPRR2 AC100-240 E5AK-TPRR2-500 AC100-240 E5AK-TPRR2-K AC100-240 E5AK-TPRR2-K-500 AC100-240	E5AN-HTPRR2BM-500 AC100-240 E5AN-HTPRR2BFM-500 AC100-240

**E5EK (1/8 DIN size)**

<b>Product discontinuation</b>	<b>Recommended replacement</b>
E5EK-AA2 E5EK-AA2-K E5EK-AA2-500 <b>E5EK-AA2-500-K</b>	E5EN-HAA2HBM-500 AC100-240 E5EN-HAA2HHBFM-500 AC100-240
E5EK-AA2-DRT AC100-240 E5EK-AA2-DRT-K AC100-240 E5EK-AA2-DRT-500 AC100-240	E5ER-QTB-DRT AC100-240 E5ER-CTB-DRT AC100-240
E5EK-PRR2 E5EK-PRR2-K E5EK-PRR2-500 <b>E5EK-PRR2-500-K</b>	E5EN-HPRR2BM-500 AC100-240 E5EN-HPRR2BFM-500 AC100-240
E5EK-TAA2 AC100-240 E5EK-TAA2-K AC100-240 E5EK-TAA2-500 AC100-240 E5EK-TAA2-K-500 AC100-240	E5EN-HTAA2HBM-500 AC100-240 E5EN-HTAA2HHBFM-500 AC100-240
E5EK-TPRR2 AC100-240 E5EK-TPRR2-500 AC100-240 E5EK-TPRR2-K AC100-240 E5EK-TPRR2-K-500 AC100-240	E5EN-HTPRR2BM-500 AC100-240 E5EN-HTPRR2BFM-500 AC100-240

**E5CK (1/16 DIN size)**

<b>Product discontinuation</b>	<b>Recommended replacement</b>
E5CK-AA1 E5CK-AA1-K E5CK-AA1-500 AC100-240 E5CK-AA1-K-500	E5CN-H__2M-500 __ means R, Q, C or V.
E5CK-TAA1 AC100-240 E5CK-TAA1-K AC100-240 E5CK-TAA1-500 AC100-240 E5CK-TAA1-K-500 AC100-240	E5CN-HT__2M-500 __ means R, Q, C or V.

**E53 Output units and Option units of E5AK, E5EK and E5CK series**

<b>Product discontinuation</b>	<b>Recommended replacement</b>
E53-AKF	None
E53-AKF-K	None
E53-R4R4	None
E53-Q4R4	None
E53-Q4HR4	None
E53-C4R4	None
E53-C4DR4	None
E53-V44R4	None
E53-Q4Q4	None
E53-Q4HQ4H	None
E53-CK01	None
E53-CK03	None
E53-CKB	None
E53-CKF	None
E53-CKF-K	None

For E5\_K series and E5\_N-H series, option units or output units are necessary.  
In another sheet "From E5\_K to E5\_N-H replace table", you can see replacement comparison including option units or output units.

# Detailed Comparison

## Dimensions (mm)

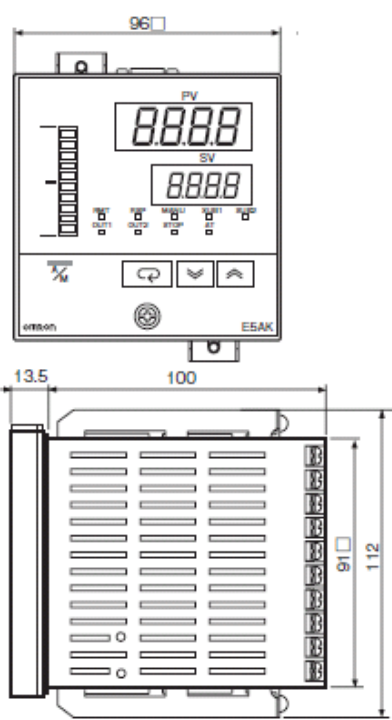
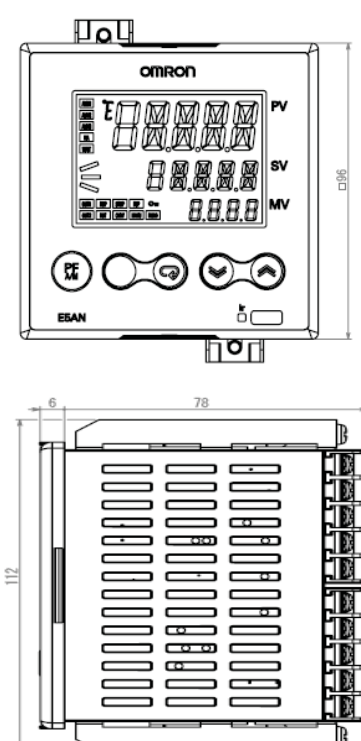
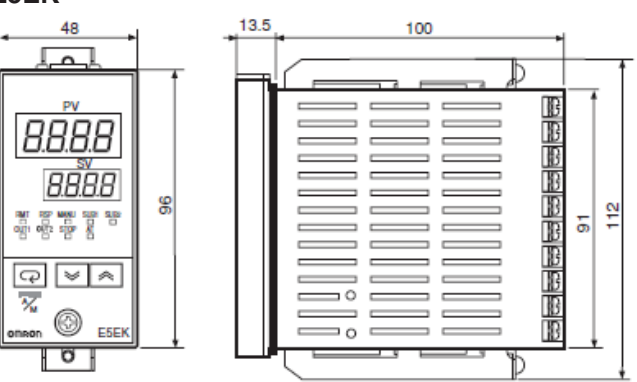
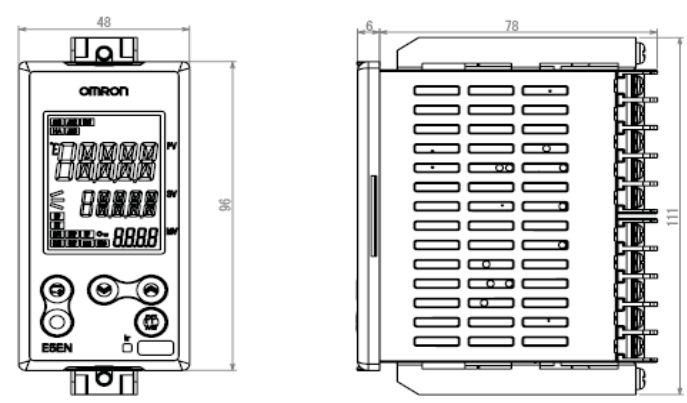
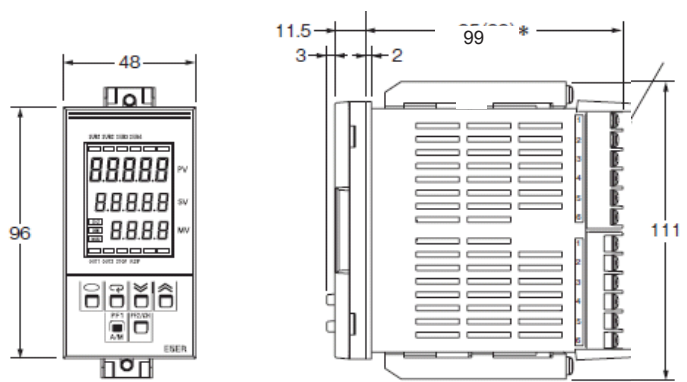
Product discontinuation	Recommended replacement
<p><b>Main Body</b> <b>E5AK</b></p> 	<p><b>Main Body</b> <b>E5AN-H</b></p> 
<p><b>E5EK</b></p> 	<p><b>E5EN-H</b></p>  <p><b>E5ER-DRT</b></p> 

Product discontinuation

**E5CK**

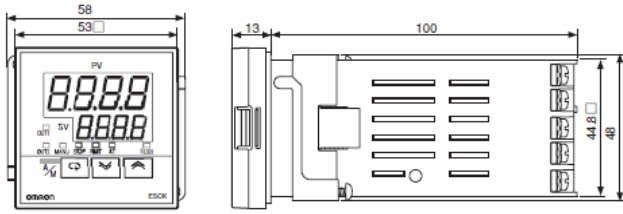

**Terminal Cover for E5AK  
E53-COV0809**

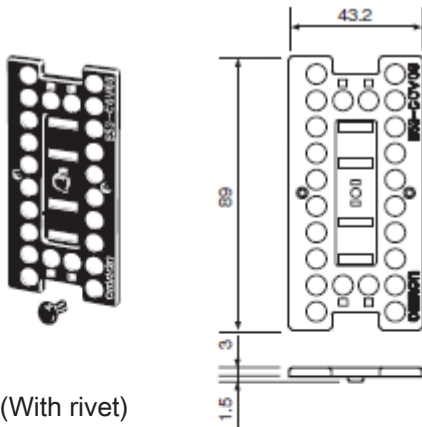

(With rivet)

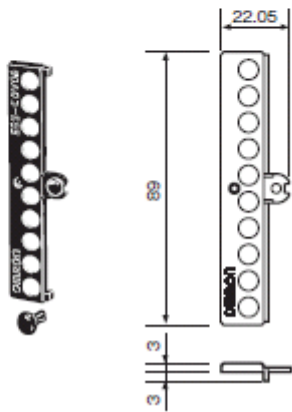

**Terminal Cover for E5EK  
E53-COV08**

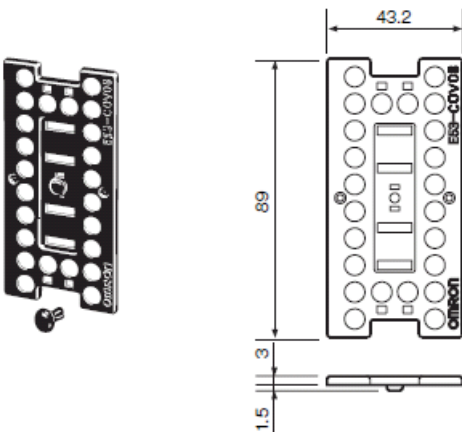

Recommended replacement

**E5CN-H**

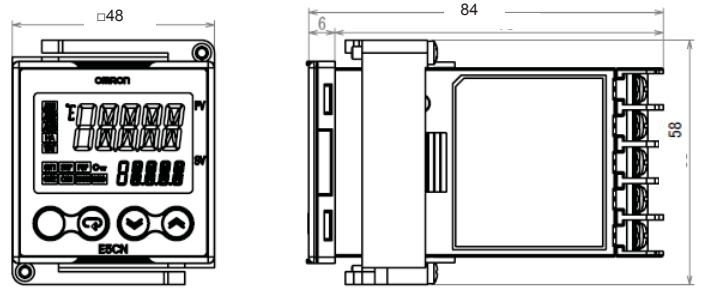

**Terminal Cover for E5AN-H/E5EN-H  
E53-COV16**

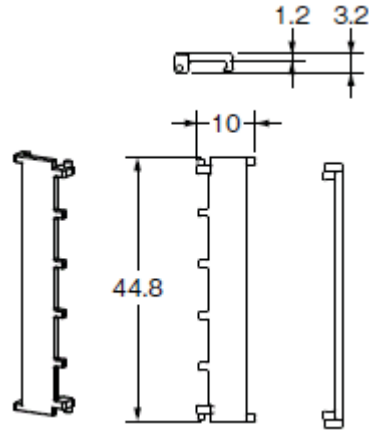

**Terminal Cover for E5ER  
E53-COV15**

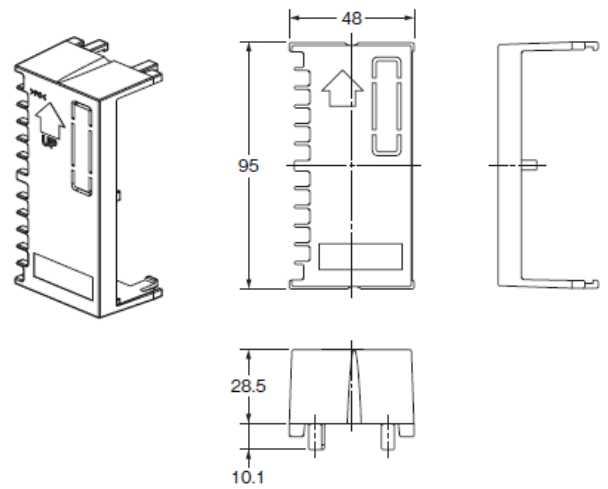

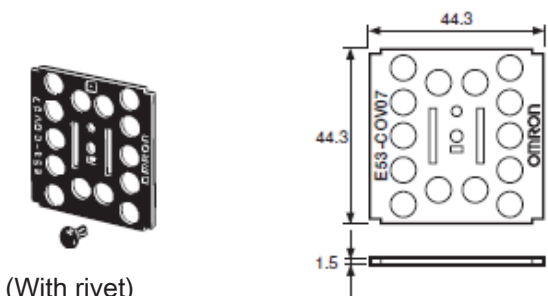
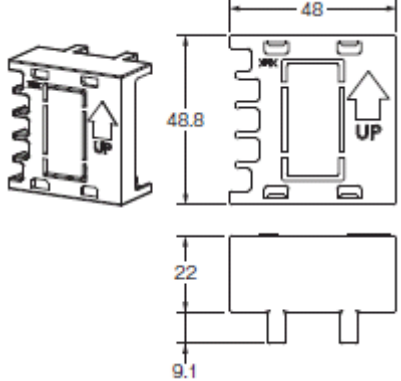
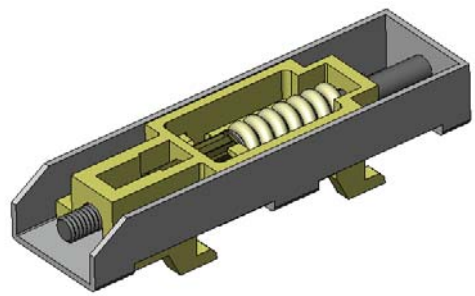
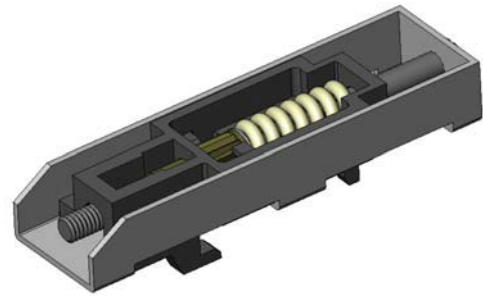
Product discontinuation	Recommended replacement
<p><b>Terminal Cover for E5CK</b> E53-COV07</p>  <p>(With rivet)</p>	<p><b>Terminal Cover for E5CN-H</b> E53-COV17</p> 
<p><b>Mounting Bracket (Prepackaged)</b> E5AK/E5EK</p> 	<p><b>Mounting Bracket (Prepackaged)</b> E5AN-H/E5EN-H</p>  <p>Note: Mounting bracket for E5AK/E5EK can not be use for E5_N-H.</p>

### Wire Connection

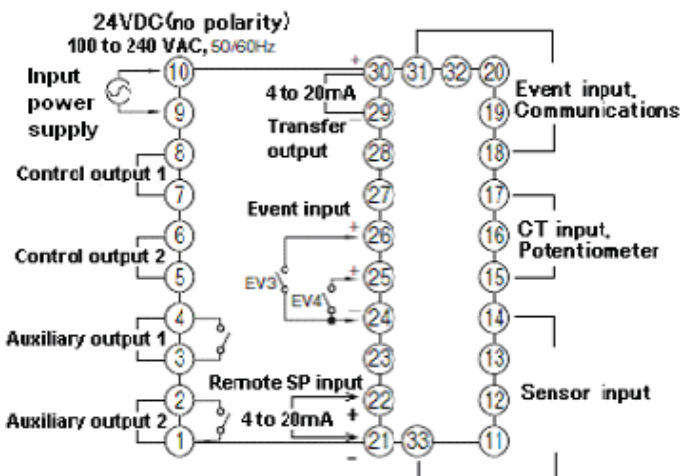
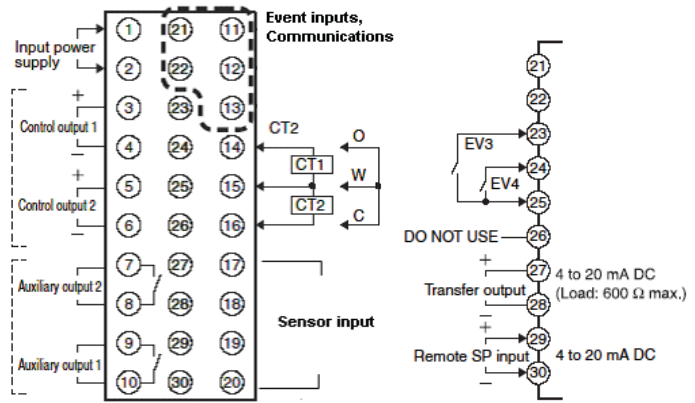
Product discontinuation	Recommended replacement
<p><b>Terminal Arrangement</b> E5AK</p> 	<p><b>Terminal Arrangement</b> E5AN-H</p> 

Product discontinuation

**Terminal Arrangement  
E5EK**

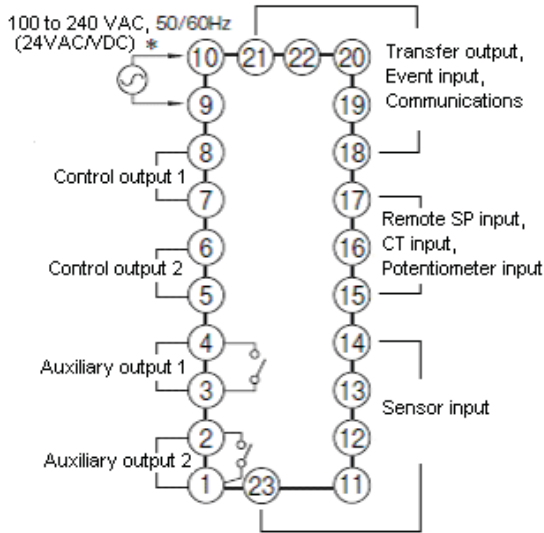

\* No polarity when 24VDC.

**E5CK**

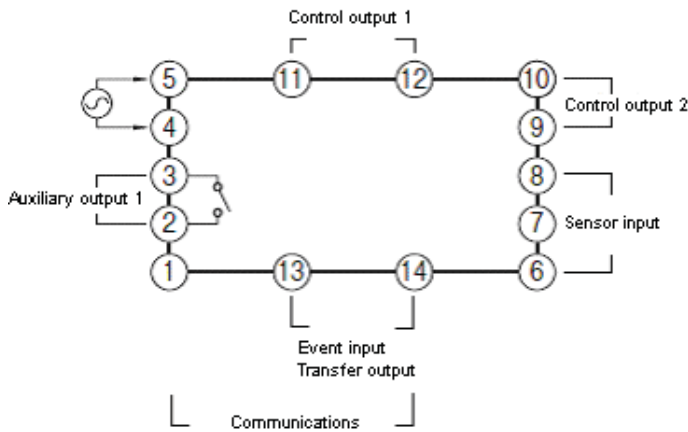

Recommended replacement

**Terminal Arrangement  
E5EN-H**

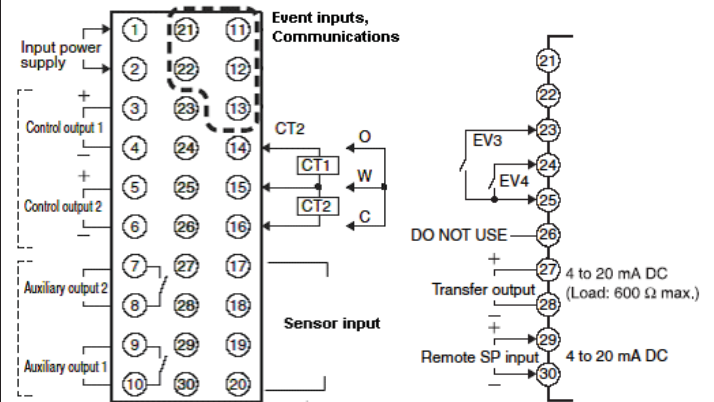

**E5ER-DRT**

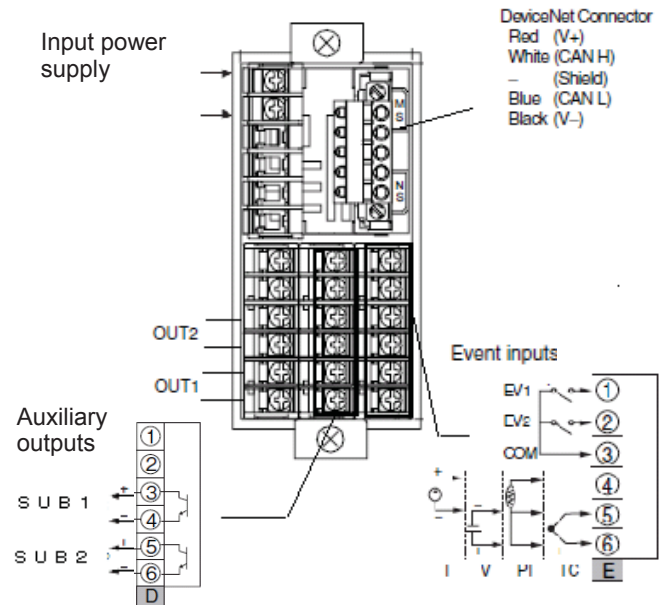

**E5CN-H**

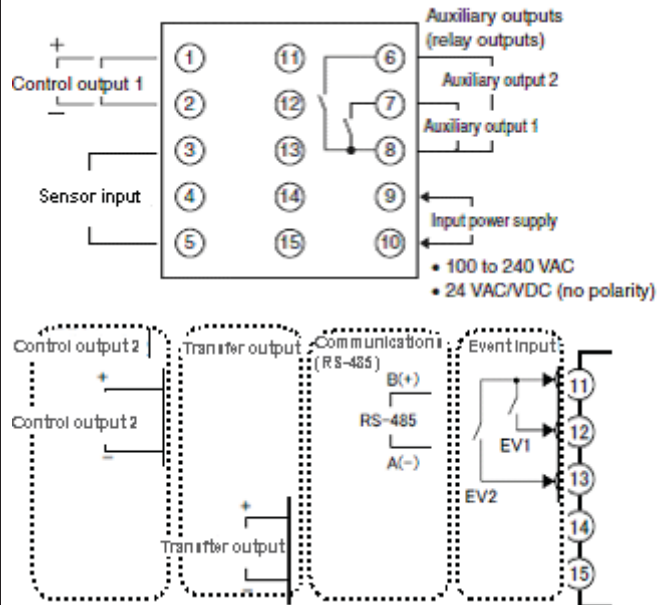

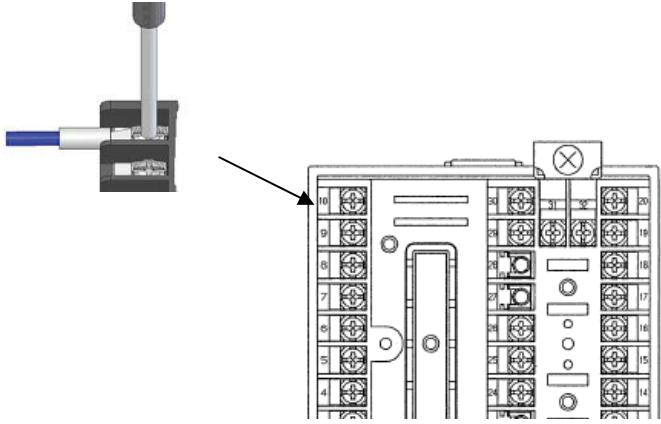
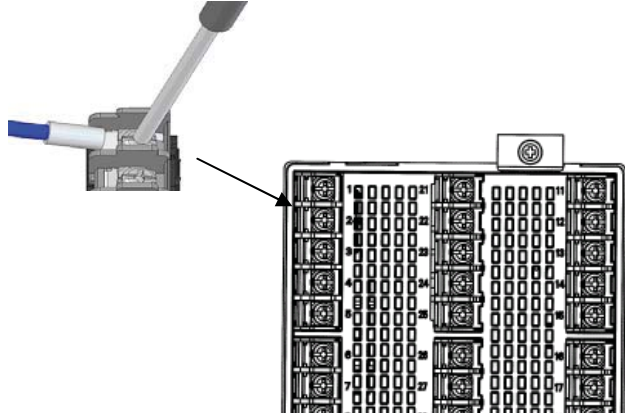
Product discontinuation	Recommended replacement
<p><b>Types of Terminal Block</b></p> <ul style="list-style-type: none"> <li>• Which way to pull out the wire: Horizontally against the block</li> </ul> 	<p><b>Types of Terminal Block</b></p> <ul style="list-style-type: none"> <li>• Which way to pull out the wire: with 15 degrees of gradient against the block</li> </ul> 

## Characteristics

Product discontinuation	Recommended replacement																																																												
<p><b>Indication accuracy</b> E5AK/E5EK/E5CK</p> <ul style="list-style-type: none"> <li>• Thermocouple: (<math>\pm 0.3\%PV</math> or <math>\pm 1^{\circ}C</math>)<math>\pm 1</math> digit</li> <li>• Platinum resistance thermometer: Pt100, JPt100 (<math>\pm 0.2\%PV</math> or <math>\pm 0.8^{\circ}C</math>) <math>\pm 1</math> digit</li> <li>• Analog input: <math>\pm 0.2\%</math> FS <math>\pm 1</math> digit</li> </ul> <p><b>Output Specifications</b> E5AK/E5EK</p> <ul style="list-style-type: none"> <li>• Current output</li> </ul> <p>Resolution: Approx. 2600</p> <ul style="list-style-type: none"> <li>• Output unit (Order separately)</li> </ul> <table border="1" data-bbox="68 1325 748 1698"> <thead> <tr> <th>No.</th> <th>Models</th> <th>Output Type</th> </tr> </thead> <tbody> <tr><td>1</td><td>E53-R</td><td>Relay</td></tr> <tr><td>2</td><td>E53-S</td><td>SSR</td></tr> <tr><td>3</td><td>E53-Q</td><td>Voltage(for driving SSR)</td></tr> <tr><td>4</td><td>E53-Q3</td><td>Voltage(for driving SSR)</td></tr> <tr><td>5</td><td>E53-Q4</td><td>Voltage(for driving SSR)</td></tr> <tr><td>6</td><td>E53-C3</td><td>Current (4 to 20mA)</td></tr> <tr><td>7</td><td>E53-C3D</td><td>Current (0 to 20mA)</td></tr> <tr><td>8</td><td>E53-V34</td><td>Linear voltage(0 to 10V)</td></tr> <tr><td>9</td><td>E53-V35</td><td>Linear voltage(0 to 10V)</td></tr> </tbody> </table>	No.	Models	Output Type	1	E53-R	Relay	2	E53-S	SSR	3	E53-Q	Voltage(for driving SSR)	4	E53-Q3	Voltage(for driving SSR)	5	E53-Q4	Voltage(for driving SSR)	6	E53-C3	Current (4 to 20mA)	7	E53-C3D	Current (0 to 20mA)	8	E53-V34	Linear voltage(0 to 10V)	9	E53-V35	Linear voltage(0 to 10V)	<p><b>Indication accuracy</b> E5AN-H/E5EN-H/E5CN-H/E5ER-DRT</p> <ul style="list-style-type: none"> <li>• Thermocouple: (<math>\pm 0.1\%PV</math> or <math>\pm 1^{\circ}C</math>)<math>\pm 1</math> digit</li> <li>• Platinum resistance thermometer: Pt100, JPt100 (<math>\pm 0.1\%PV</math> or <math>\pm 0.8^{\circ}C</math>) <math>\pm 1</math> digit</li> <li>• Analog input: <math>\pm 0.1\%</math> FS <math>\pm 1</math> digit</li> </ul> <p><b>Output Specifications</b> E5AN-H/E5EN-H</p> <ul style="list-style-type: none"> <li>• Current output</li> </ul> <p>Resolution: Approx. 10000</p> <ul style="list-style-type: none"> <li>• Output unit (Order separately)</li> </ul> <table border="1" data-bbox="833 1325 1541 1698"> <thead> <tr> <th>No.</th> <th>Models</th> <th>Output Type</th> </tr> </thead> <tbody> <tr><td>1</td><td>E53-RN</td><td>Relay</td></tr> <tr><td>2</td><td>None</td><td>SSR</td></tr> <tr><td>3</td><td>E53-QN</td><td>Voltage(for driving SSR)</td></tr> <tr><td>4</td><td>E53-Q3</td><td>Voltage(for driving SSR)</td></tr> <tr><td>5</td><td>E53-Q4</td><td>Voltage(for driving SSR)</td></tr> <tr><td>6</td><td>E53-C3N</td><td>Current (4 to 20mA)</td></tr> <tr><td>7</td><td>E53-C3DN</td><td>Current (0 to 20mA)</td></tr> <tr><td>8</td><td>E53-V34N</td><td>Linear voltage(0 to 10V)</td></tr> <tr><td>9</td><td>E53-V35N</td><td>Linear voltage(0 to 10V)</td></tr> </tbody> </table>	No.	Models	Output Type	1	E53-RN	Relay	2	None	SSR	3	E53-QN	Voltage(for driving SSR)	4	E53-Q3	Voltage(for driving SSR)	5	E53-Q4	Voltage(for driving SSR)	6	E53-C3N	Current (4 to 20mA)	7	E53-C3DN	Current (0 to 20mA)	8	E53-V34N	Linear voltage(0 to 10V)	9	E53-V35N	Linear voltage(0 to 10V)
No.	Models	Output Type																																																											
1	E53-R	Relay																																																											
2	E53-S	SSR																																																											
3	E53-Q	Voltage(for driving SSR)																																																											
4	E53-Q3	Voltage(for driving SSR)																																																											
5	E53-Q4	Voltage(for driving SSR)																																																											
6	E53-C3	Current (4 to 20mA)																																																											
7	E53-C3D	Current (0 to 20mA)																																																											
8	E53-V34	Linear voltage(0 to 10V)																																																											
9	E53-V35	Linear voltage(0 to 10V)																																																											
No.	Models	Output Type																																																											
1	E53-RN	Relay																																																											
2	None	SSR																																																											
3	E53-QN	Voltage(for driving SSR)																																																											
4	E53-Q3	Voltage(for driving SSR)																																																											
5	E53-Q4	Voltage(for driving SSR)																																																											
6	E53-C3N	Current (4 to 20mA)																																																											
7	E53-C3DN	Current (0 to 20mA)																																																											
8	E53-V34N	Linear voltage(0 to 10V)																																																											
9	E53-V35N	Linear voltage(0 to 10V)																																																											

Product discontinuation	Recommended replacement
<p><b>Output Specifications</b> E5CK</p> <ul style="list-style-type: none"> <li>• <u>Control output 1</u> Resolution for current/linear voltage output: Approx. 2600 Load for current output: 500Ω max. Linear current output: 4 to 20mA Linear voltage output: 0 to 10 VDC, Load 1kΩ min Voltage output: 12VDC, 20mA, NPN Relay output: SPST-NO, 250VAC, 3A (resistive load)</li> <li>• Control output 2 Voltage output: 12 VDC, 20mA, NPN Relay output: SPST-NO, 250 VAC, 3A (resistive load)</li> <li>• Auxiliary output Relay output: SPST-NO, 250 VAC ,1A (resistive load) (1 output)</li> </ul> <p><b>Transfer output</b> E5AK/E5EK/E5CK</p> <ul style="list-style-type: none"> <li>• Resolution: Approx. 2600</li> </ul> <p>E5AK/E5EK</p> <ul style="list-style-type: none"> <li>• Load: 600Ω max</li> </ul> <p>E5CK</p> <ul style="list-style-type: none"> <li>• Load: 500Ω max</li> </ul> <p><b>Sampling period</b> E5AK/E5EK/E5CK</p> <ul style="list-style-type: none"> <li>• Temperature input: 250ms</li> <li>• Analog input: 100ms</li> </ul> <p><b>Temperature effect on signal source resistance</b> E5AK/E5EK/E5CK</p> <ul style="list-style-type: none"> <li>• Thermocouple (K, J ,T, E, L, N, U): 0.1°C/Ω</li> <li>• Thermocouple (B, R, S): 0.2°C/Ω</li> <li>• Platinum resistance thermometer: 0.4°C/Ω</li> </ul> <p><b>Event input</b> E5AK/E5EK/E5CK</p> <ul style="list-style-type: none"> <li>• Event input: 2 max</li> </ul>	<p><b>Output Specifications</b> E5CN-H</p> <ul style="list-style-type: none"> <li>• <u>Control output 1</u> Resolution for current/linear voltage output: Approx. 10000 Load for current output: 600Ω max. Linear current output: 4 to 20mA Linear voltage output: 0 to 10 VDC, Load 1kΩ min Voltage output: 12 VDC, 21mA, PNP Relay output: SPST-NO, 250 VAC, 3A (resistive load)</li> <li>• Control output 2 Voltage output: 12 VDC, 21mA, PNP Relay output: SPST-NO, 250 VAC, 3A (resistive load)</li> <li>• Auxiliary output Relay output: SPST-NO, 250 VAC ,3A (resistive load) (2 outputs)</li> </ul> <p><b>E5ER-DRT</b></p> <ul style="list-style-type: none"> <li>• Control output Resolution for current/linear voltage output: Approx. 43000 Load for current output: 500Ω max. Linear current output: 4 to 20mA Voltage output: 12VDC, 40mA, PNP <b>Relay output: SPST-NO, 250VAC, 1A(inductive load)</b></li> <li>• Auxiliary output <b>Relay output: SPST-NO, 250VAC, 1A(resistive load)</b> Transistor output: 30VDC, 50mA, NPN</li> </ul> <p><b>Transfer output</b> E5AN-H/E5EN-H/E5CN-H</p> <ul style="list-style-type: none"> <li>• Resolution: Approx. 10000</li> <li>• Load: 600Ω max</li> </ul> <p>E5ER-DRT</p> <ul style="list-style-type: none"> <li>• Resolution: Approx. 43000</li> <li>• Load: 500Ω max</li> </ul> <p><b>Sampling period</b> E5AN-H/E5EN-H/E5CN-H</p> <ul style="list-style-type: none"> <li>• Temperature input: 60ms</li> <li>• Analog input: 60ms</li> </ul> <p>E5ER-DRT</p> <ul style="list-style-type: none"> <li>• Temperature input: 50ms</li> <li>• Analog input: 50ms</li> </ul> <p><b>Temperature effect on signal source resistance</b> E5AN-H/E5EN-H/E5CN-H</p> <ul style="list-style-type: none"> <li>• Thermocouple: 0.1°C/Ω</li> <li>• Platinum resistance thermometer: 0.1°C/Ω</li> </ul> <p><b>Event input</b> E5AN-H/E5EN-H</p> <ul style="list-style-type: none"> <li>• Event input: 4 max</li> </ul> <p>E5CN-H</p> <ul style="list-style-type: none"> <li>• Event input: 2 max</li> </ul>



Product discontinuation	Recommended replacement
<p><b>Communications</b> E5AK/E5EK/E5CK</p> <ul style="list-style-type: none"> <li>• Baud rate: 1200/2400/4800/9600/19200 bps</li> <li>• Communication protocol: Sysway (For E5_K) Sysway (X format)</li> </ul> <p><b>Heater burnout, Heater overcurrent detection</b> E5AK/E5EK</p> <ul style="list-style-type: none"> <li>• Heater burnout detection (For Single-phase)</li> </ul> <p>E5CK None</p> <p><b>Program capacity</b> E5AK-T 8 patterns, 16 steps E5EK-T/E5CK-T 4 patterns, 16 steps</p> <p><b>Program method</b> E5AK-T/E5EK-T/E5CK-T Time or ramp setting method</p>	<p><b>Communications</b> E5AN-H/E5EN-H/E5CN-H</p> <ul style="list-style-type: none"> <li>• Baud rate: 1200/2400/4800/9600/19200/38400/57600bps</li> <li>• Communication protocol: Sysway (X format) CompoWay/F, Modbus</li> </ul> <p><b>Heater burnout, Heater overcurrent detection</b> E5AN-H/E5EN-H</p> <ul style="list-style-type: none"> <li>• Heater burnout detection (For Three-phase)</li> <li>• Heater overcurrent detection (For Three-phase)</li> </ul> <p>E5CN-H</p> <ul style="list-style-type: none"> <li>• Heater burnout detection (For Single-phase/Three-phase)</li> <li>• Heater overcurrent detection (For Single-phase/ Three-phase)</li> </ul> <p><b>Program capacity</b> E5AN-HT/E5EN-HT/E5CN-HT 8 patterns, 32 steps</p> <p><b>Program method</b> E5AN-HT/E5EN-HT/E5CN-HT Time or ramp setting method</p>

# Display and Operation Methods

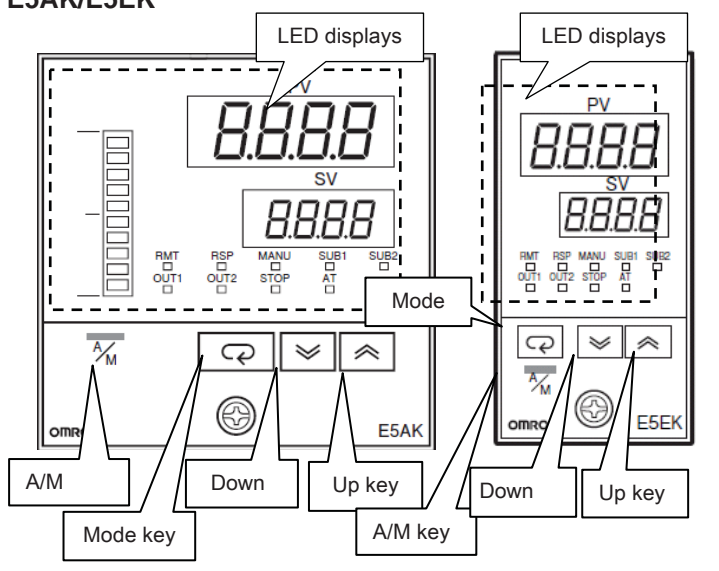
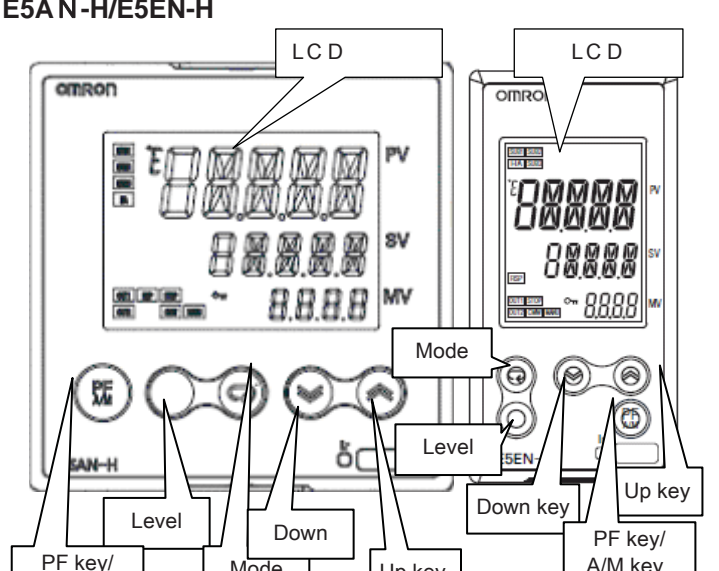
Product discontinuation	Recommended replacement
<p><b>Front panel E5AK/E5EK</b></p>  <p>The diagram shows two views of the E5AK/E5EK front panel. The left view shows the LED displays with 'PV' and 'SV' labels. The right view shows the control buttons: A/M, Mode, Down, and Up key. Labels include 'LED displays', 'Mode', 'A/M', 'Down', and 'Up key'.</p> <div data-bbox="97 819 779 966" style="border: 1px solid black; padding: 5px;"> <p>〈E5AK/E5EK〉            PV : 4 digits (Red Constant),            Letter height: 15mm            SV : 4 digits (Green Constant)</p> </div>	<p><b>Front panel E5AN-H/E5EN-H</b></p>  <p>The diagram shows two views of the E5AN-H/E5EN-H front panel. The left view shows the LCD displays with 'PV', 'SV', and 'MV' labels. The right view shows the control buttons: PF key/A/M key, Level, Mode, Down, Up key, Down key, and Up key. Labels include 'LCD', 'Mode', 'Level', 'Down', 'Up key', 'Down key', and 'PF key/A/M key'.</p> <div data-bbox="844 819 1526 966" style="border: 1px solid black; padding: 5px;"> <p>〈E5AN/E5EN〉            PV : 5 digits (Red/Green/Orange Selectable)            Letter height: 15.8mm            SV : 5 digits (Green constant)            MV : 4 digits (Orange Constant)</p> </div>

Product discontinuation

Front panel  
E5CK

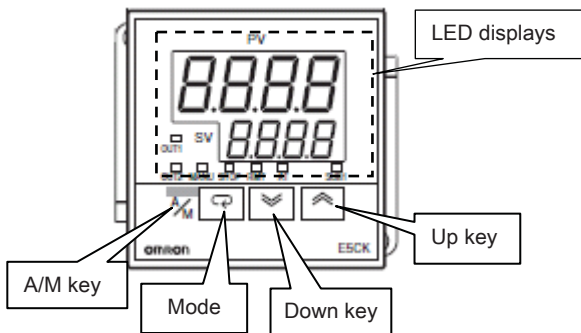

PV : 4 digits (Red Constant), Letter height 12mm  
SV : 4 digits (Green Constant)

Recommended replacement

Front panel  
E5ER-DRT

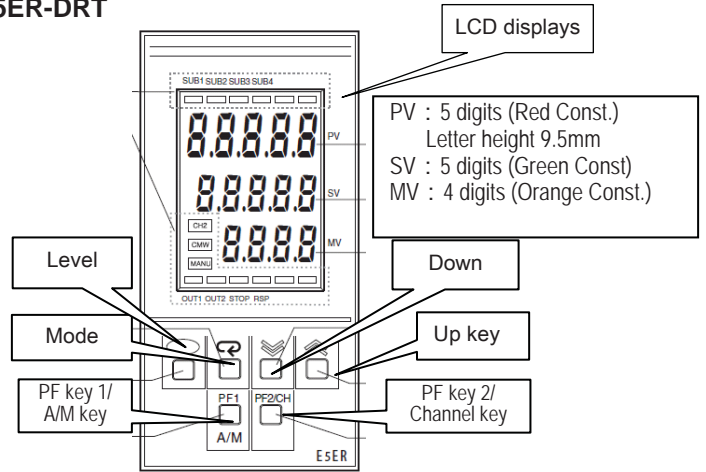

PV : 5 digits (Red Const.)  
Letter height 9.5mm  
SV : 5 digits (Green Const.)  
MV : 4 digits (Orange Const.)

Front panel  
E5CN-H

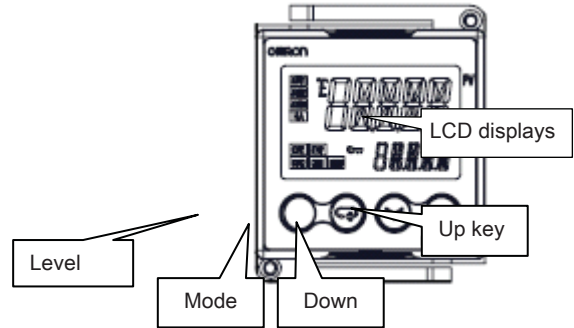

PV : 5 digits (Red/Green/Orange Selectable), Letter height 12mm  
SV : 5 digits (Green Constant)

Product discontinuation

**Body Draw out  
E5EK**

When drawing out the internal mechanism from the housing, prepare a phillips screwdriver matched to the size of the screw on the lower part of the front panel.

- (1) Press down on the hook on the top of the front panel and turn the phillips screwdriver to the left to loosen the screw on the lower part of the front panel.

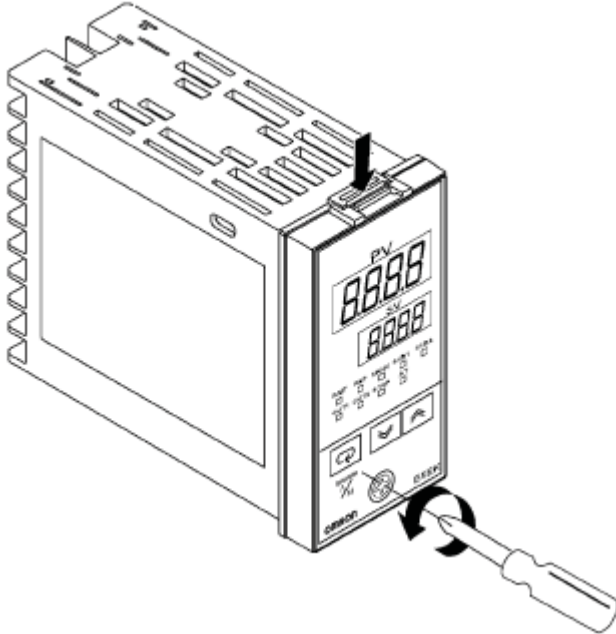

Recommended replacement

**Body Draw out  
E5EN-H**

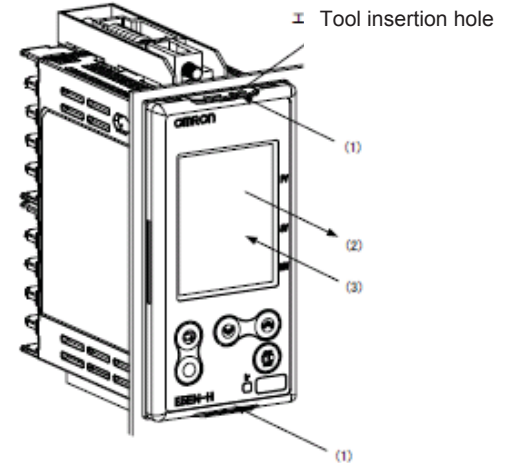

1. Insert a flat-blade screwdriver into the two tool insertion holes (one on the top and one on the bottom) to release the hooks.
2. Insert a flat-blade screwdriver in the gap between the front panel and rear case (two on the top and two on the bottom), and use it to pry and pull out the front panel slightly. Then, pull out on the front panel gripping both sides. Be sure not to impose excessive force on the panel.
3. When inserting the body of the Digital Controller into the case, make sure the PCBs are parallel to each other, make sure that the sealing rubber is in place, and press the E5EN-H toward the rear case until it snaps into position. While pressing the E5EN-H into place, press down on the hooks on the top and bottom surfaces of the rear case so that the hooks securely lock in place. Make sure that electronic components do not come into contact with the case.

**E5ER-DRT**

You do not need to draw out in standard use. Please draw out by the method similar to E5AN-H/ E5EN-H when you maintain it.

**Body Draw out  
E5CK**

- (1) Pull out the internal mechanism while pressing the hooks on the left and right sides of the front panel.

- (2) Draw out the internal mechanism towards you holding both sides of the front panel.

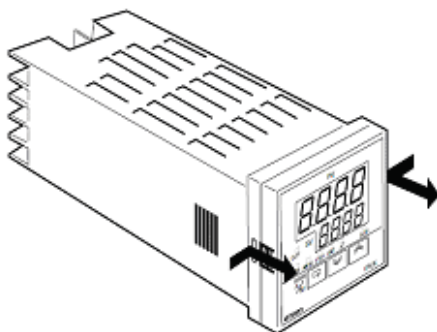

**Body Draw out  
E5CN-H**

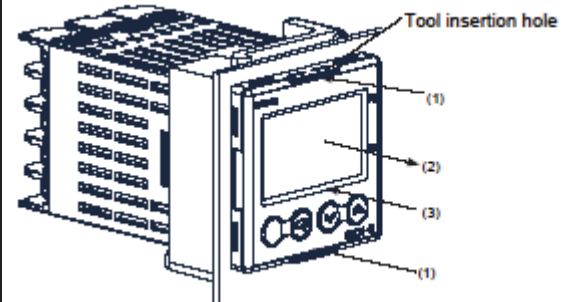

- (1) Insert a flat-blade screwdriver into the two tool insertion holes (one on the top and one on the bottom) to release the hooks.
- (2) Insert the flat-blade screwdriver in the gap between the front panel and rear case, and pull out the front panel slightly. Hold the top and bottom of the front panel and carefully pull it out toward you, without applying unnecessary force.
- (3) When inserting the body of the Digital Controller into the case, make sure the PCBs are parallel to each other, make sure that the sealing rubber is in place, and press the E5CN-H all the way to the rear case. While pushing the E5CN-H into place, push down on the hooks on the top and bottom surfaces of the rear case so that the hooks are securely locked in place. Be sure that electronic components do not come into contact with the case.

Product discontinuation	Recommended replacement
<p><b>Jumper Settings</b> <b>E5CK</b></p> <ul style="list-style-type: none"> <li>• After setting the input type by jumper, parameter can be set when an analog input is selected.</li> <li>• Set the input type by jumper to any one of temperature input, voltage input or current input matched to the sensor connected to the input terminal.</li> </ul> <div data-bbox="310 390 607 604" style="text-align: center;"> <p>I : Current input    V : Voltage input</p> <p>TC.PT : Temperature input</p> </div>	<p><b>Jumper Settings</b> <b>E5CN-H</b></p> <p>Setting the input type only by parameters due to no jumper.</p>

## Reference Documents

Description	Media	Publication Number
<b><i>E5_K Series Documents</i></b>		
E5AK/E5EK Data Sheet	PDF	<a href="#">H084-E1-05</a>
E5CK Data Sheet	PDF	<a href="#">H079-E1-06</a>
E5AK Users Manual	PDF	<a href="#">H083-E1-03</a>
E5CK Users Manual	PDF	<a href="#">H078-E1-03D</a>
E5EK Users Manual	PDF	<a href="#">H085-E1-03</a>
E5AK-T Users Manual	PDF	<a href="#">H088-E1-02</a>
E5EK-T Users Manual	PDF	<a href="#">H089-E1-02</a>
E5CK-T Users Manual	PDF	<a href="#">H090-E1-01B</a>
E5EK-DRT Users Manual	PDF	<a href="#">H099-E1-02</a>
<b><i>E5_N-H Series Documents</i></b>		
E5_N-H Data Sheet	PDF	<a href="#">H160-E1-01A</a>
E5_N-H Users Manual	PDF	<a href="#">H157-E1-03</a>
E5_N-H Communications Manual	PDF	<a href="#">H159-E1-02</a>
<b><i>E5_N-HT Series Documents</i></b>		
E5AN-HT/E5EN-HT Data Sheet	PDF	<a href="#">CSM E5AN-HT E5EN-HT DS E 1 1</a>
E5CN-HT Data Sheet	PDF	<a href="#">CSM E5CN-HT DS E 1 1</a>
E5_N-HT Users Manual	PDF	<a href="#">H169-E1-01</a>
E5_N-HT Communications Manual	PDF	<a href="#">H170-E1-01</a>