

AutoDevKit adaptive front lighting kit

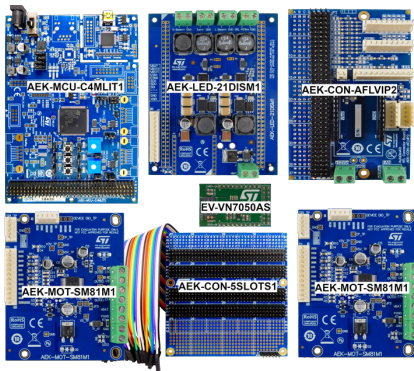

Features

- Combination of boards to create an automatic front light adjustment system (AFL)
- Entire system controlled and monitored by MCU board
- Fully compatible with AEKD-AFLLIGHT1 head light simulator available separately, with following loads:
 - two stepper motors for light projection angle adjustment (X and Y directions)
 - LED string currents for high beam, low beam, DRL and direction lights
 - a cooling fan
- Includes STSW-AFL001 firmware ready to be flashed on control board SPC58 MCU with demo application software for independent control of above loads
- Dedicated connector board for easy connection and disconnection of boards during testing and prototyping
- Additional generic connector board facilitates connector pin reassignments and board stacking
- WEEE and RoHS compliant
- All ST components are qualified Automotive grade
- All boards are packaged independently
- Part of the AutoDevKit initiative

Description

The **AEKD-AFL001** represents the complete logic and driving hardware for an adaptive front lighting system for prototyping, testing and development purposes. It consists of several AutoDevKit boards designed for motor vehicle application development featuring ST automotive-grade components.

The set includes two stepper motor control boards, a four-channel LED driver board, a control board with MCU, a connector board with a FAN switch board and another connector board for wiring configuration.

The **STSW-AFL001** adaptive front lighting system firmware runs on the control board automotive-grade SPC5 Chorus MCU and allows independent control of all the function boards and their respective loads. The package also includes sample applications to help users familiarize themselves with the code more quickly.

You can also order our fully compatible demo motor vehicle front lighting assembly (**AEKD-AFLLIGHT1**) with LED lights, stepper motors and a fan to provide a complete adaptive front lighting tool for application and solution development purposes.

Product summary	
AutoDevKit adaptive front lighting kit	AEKD-AFL001
AutoDevKit adaptive front lighting kit firmware	STSW-AFL001
MCU discovery board for SPC5 Chorus 4M automotive microcontroller with CAN transceivers	AEK-MCU-C4MLIT1
AutoDevKit stepper motor driver board for automotive applications	AEK-MOT-SM81M1
AutoDevKit digitally controlled LED driver board	AEK-LED-21DISM1
5 slot AutoDevKit connector board	AEK-CON-5SLOTS1
AutoDevKit connector board	AEK-CON-AFLVIP2

Product summary	
code generator, quick resource configurator and Eclipse development environment for SPC5 MCUs	SPC5-STUDIO
Applications	Adaptive front lighting systems for vehicles Car chassis lighting

1 Adaptive front lighting simulation tool overview

The set of AutoDevKit boards in this kit, together with the relevant firmware and sample application code in the [STSW-AFL001](#) software package, form a system that is able to control and drive an automotive adaptive front loading system for development purposes.

To build a complete physical simulation tool, the system must be complemented with appropriate loads, feedback sensors and communication ports.

Figure 1. AutoDevKit adaptive front lighting system block diagram

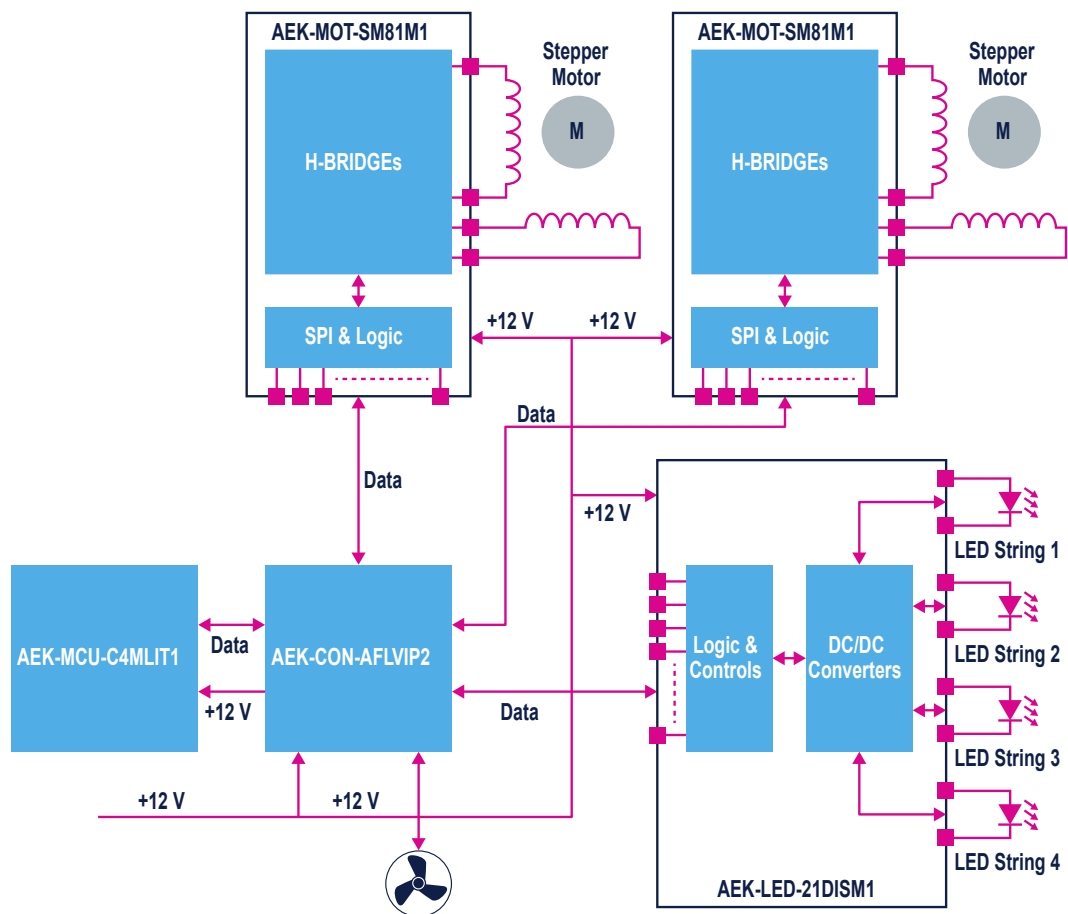

In the block diagram above, the loads are clearly indicated by the following elements:

- two stepper motors: one for up-down and one for lateral angular displacement of a light
- four LED lighting strings: high beam, low beam, DRL, direction light
- a cooling fan

ST conveniently supplies all of the above items in a single [AEKD-AFLIGHT1](#) assembly inside a specially designed acrylic shroud with appropriate cabling and connectors.

Figure 2. Adaptive front lighting headlight assembly

1. Perspex headlight housing
2. turn indicator LED string
3. high beam LED light
4. low beam LED light
5. daytime running light LED string
6. adaptive X-axis position stepper motor
7. adaptive Y-axis position stepper motor
8. cooling fan
9. JPX2 connector
10. JPX3 connector

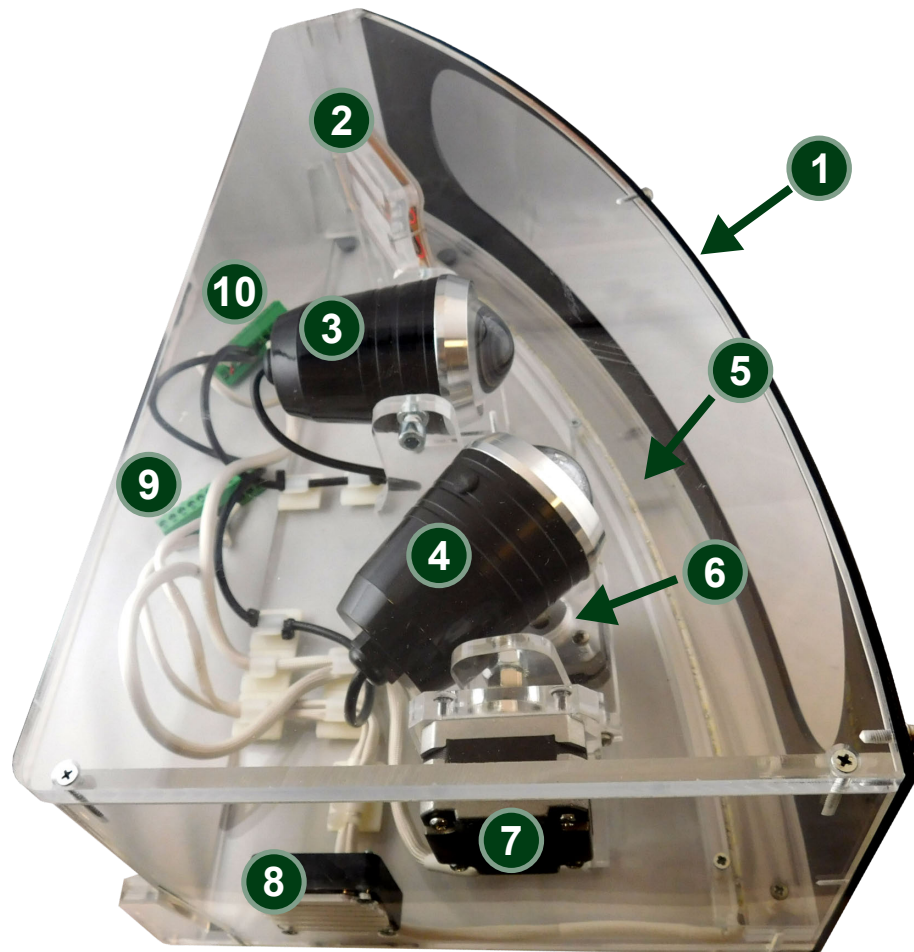

A real adaptive front lighting system would receive feedback data from sensors indicating the position or orientation of the motor vehicle steering wheel. This feedback information can be emulated with a potentiometer signal plugged to connector J5 (labeled ST.WHEEL) on the [AEK-CON-AFLVIP2](#) connector board, where different voltages will represent different steering wheel positions.

Important:

In order to enable manual steering wheel control, you must open the AutoDevKit library AFL demo project in [SPC5-STUDIO](#) and change the `#DEFINE AFLDemo_ManualMode` to `true` in the `AFL.h` file.

To ensure that manual operation does not remain the default mode when the system starts, short pins 5 and 6 of the J5 connector.

Figure 3. AEK-CON-AFLVIP2 J4 (ST.WHEEL) and J5 (CAN) connectors

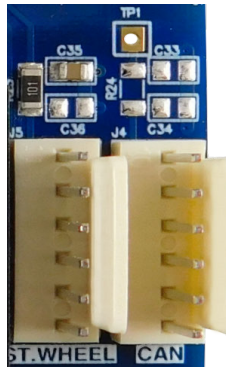

To connect the electronic control unit (ECU) with other ECUs such as the body control module (BCM) and/or cluster (to signal the actuation being performed on the dashboard), you can connect a CAN bus analyzer to connector J4 (labeled CAN) on the [AEK-CON-AFLVIP2](#) connector board. The analyzer shows the basic CAN messages that are transmitted when a single actuation in the headlight is performed. The CAN messages and periodicity can be customized using [SPC5-STUDIO](#) to edit the AFL demo available in the AutoDevKit library.

RELATED LINKS

[AutoDevKit: Adaptive Front Lighting demonstration kit video on YouTube](#)

2 AEK-MCU-C4MLIT1 schematic diagrams

Figure 4. AEK-MCU-C4MLIT1 schematic - power supply

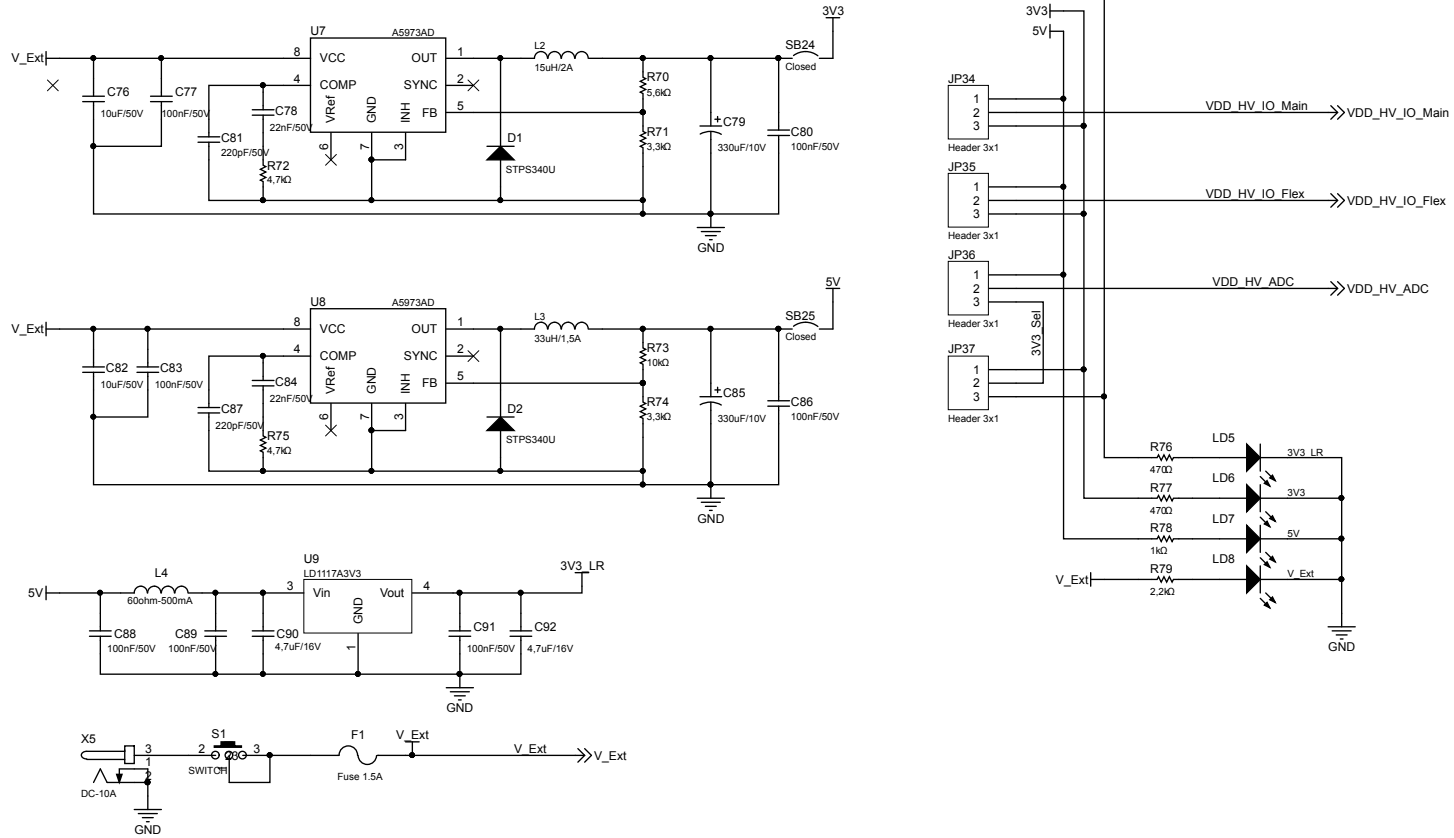

Figure 5. AEK-MCU-C4MLIT1 schematic - USB and debugger

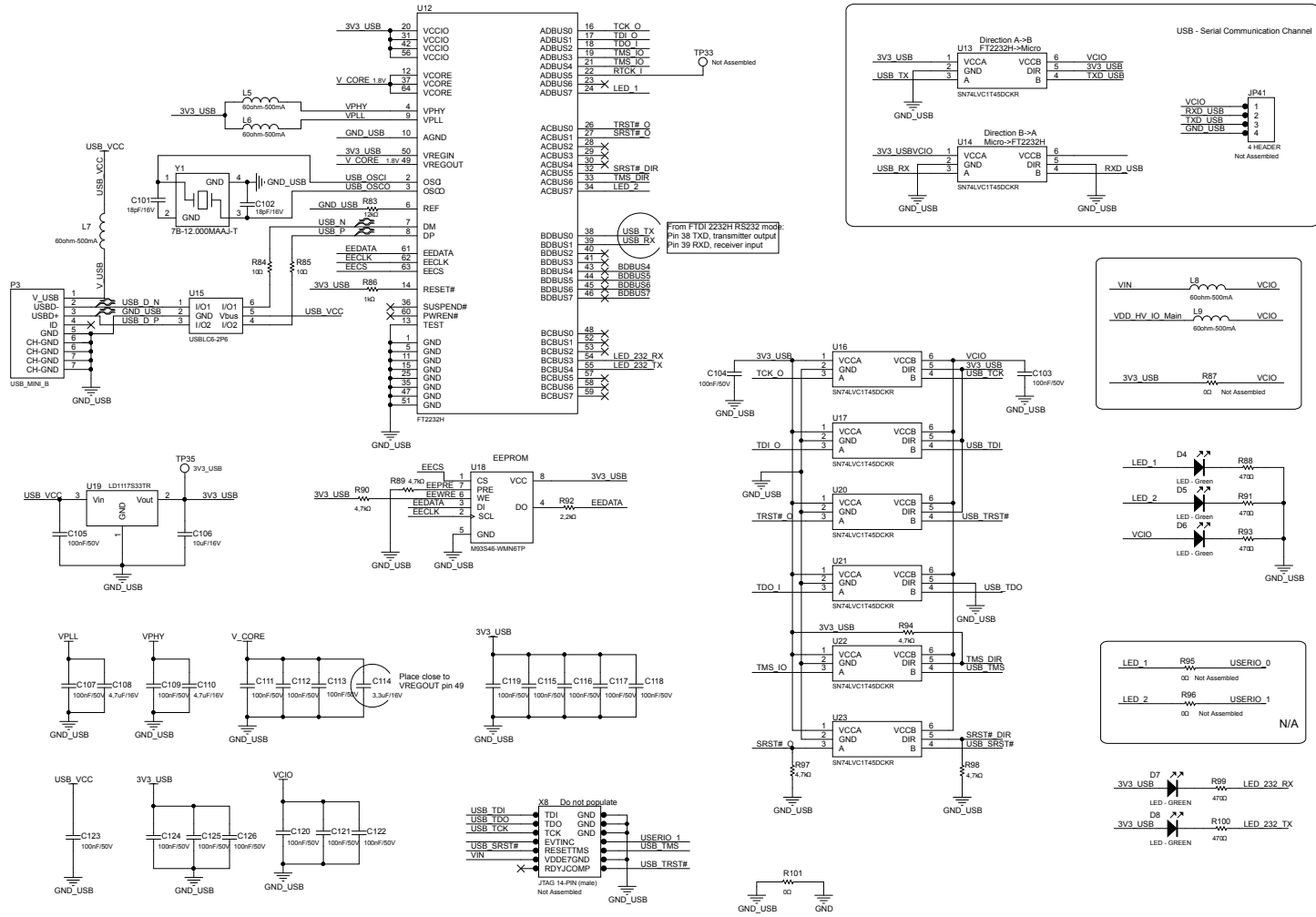

Figure 6. AEK-MCU-C4MLIT1 schematic - JTAG, Reset and ST33 connector

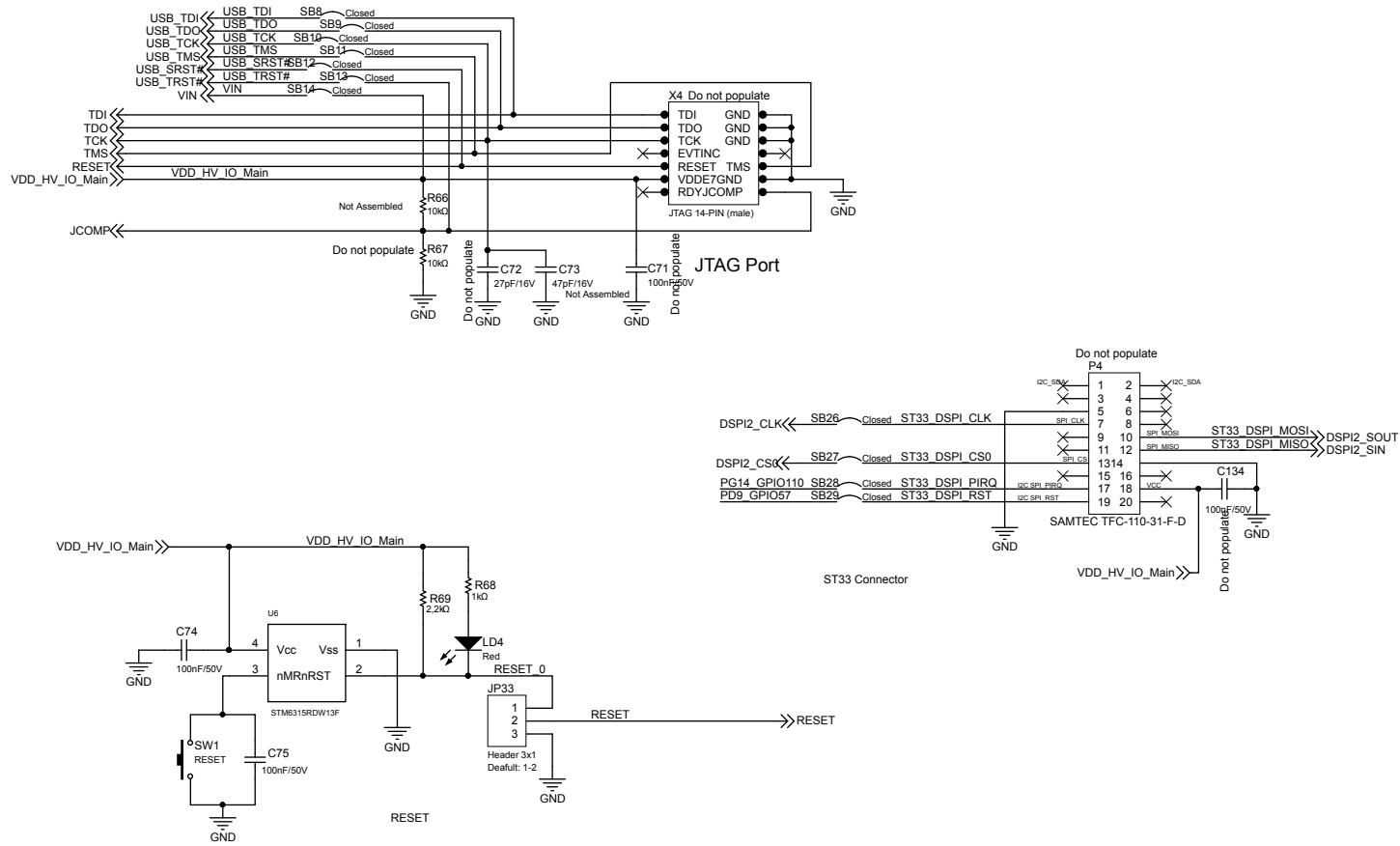

Figure 7. AEK-MCU-C4MLIT1 schematic - RS232 and LIN

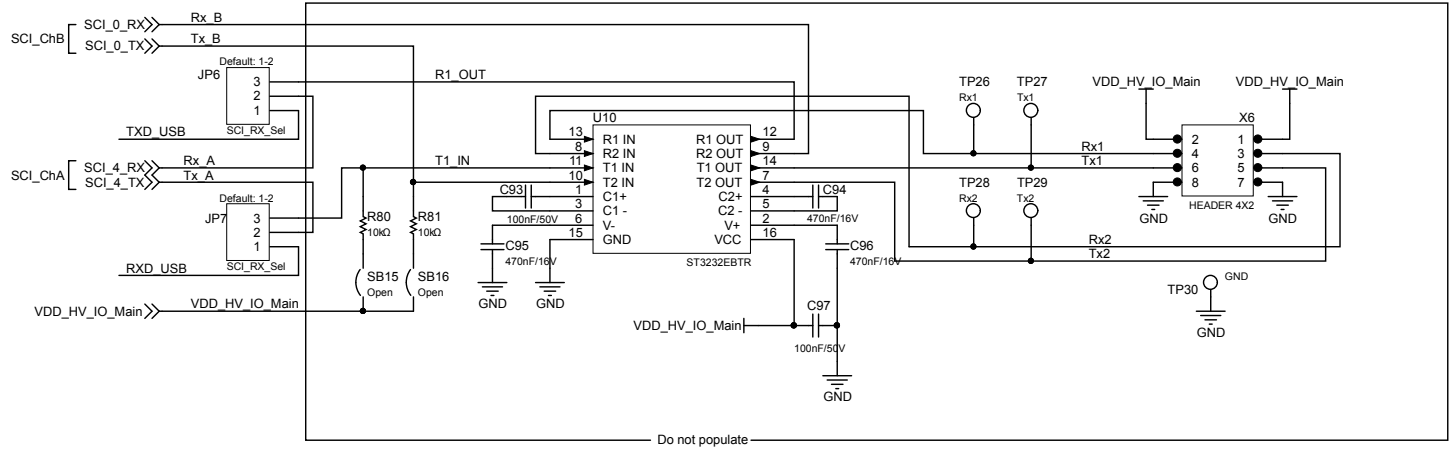

Figure 8. AEK-MCU-C4MLIT1 schematic - jumpers for serial and CAN

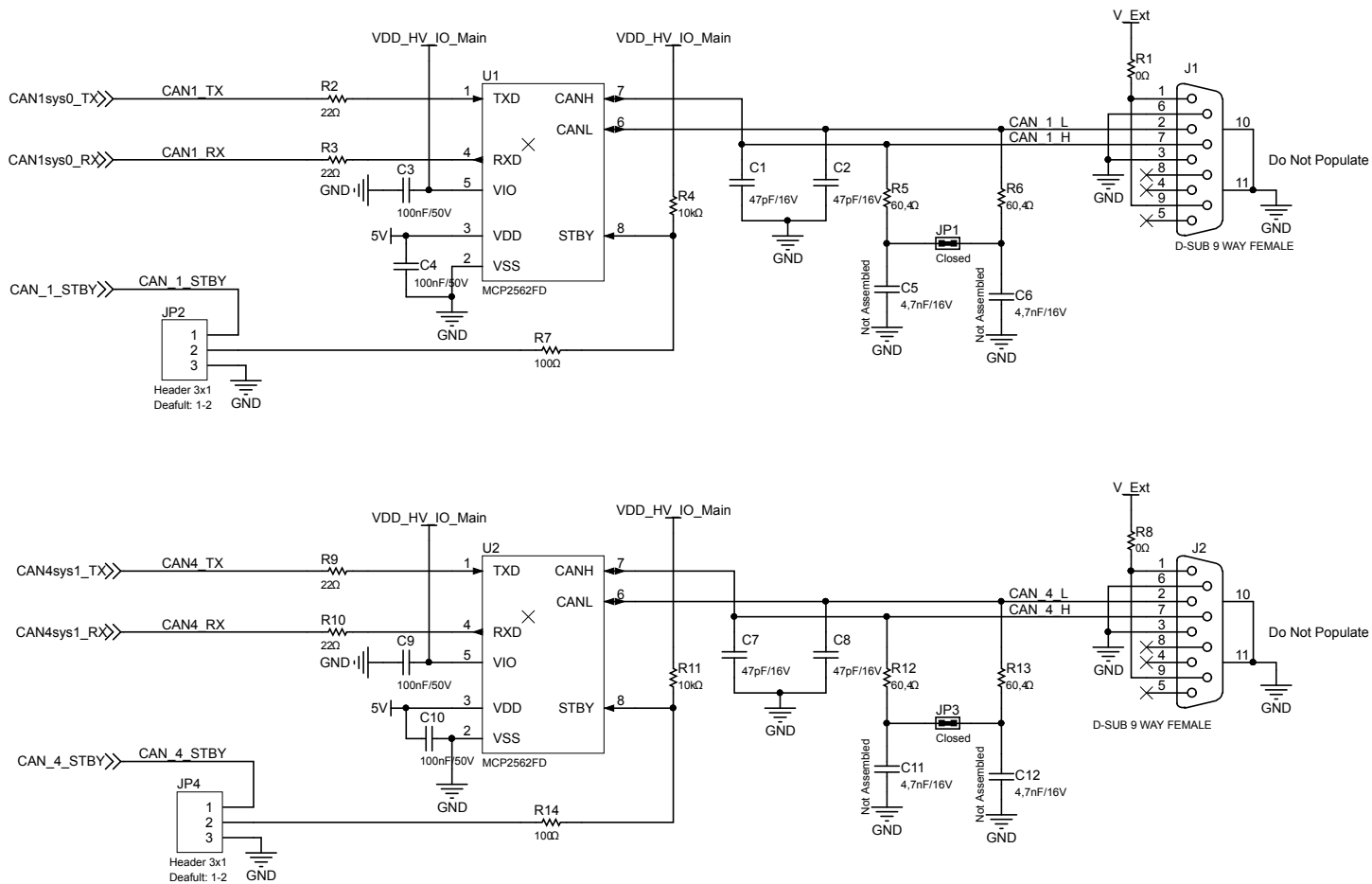

Figure 9. AEK-MCU-C4MLIT1 schematic - user interface

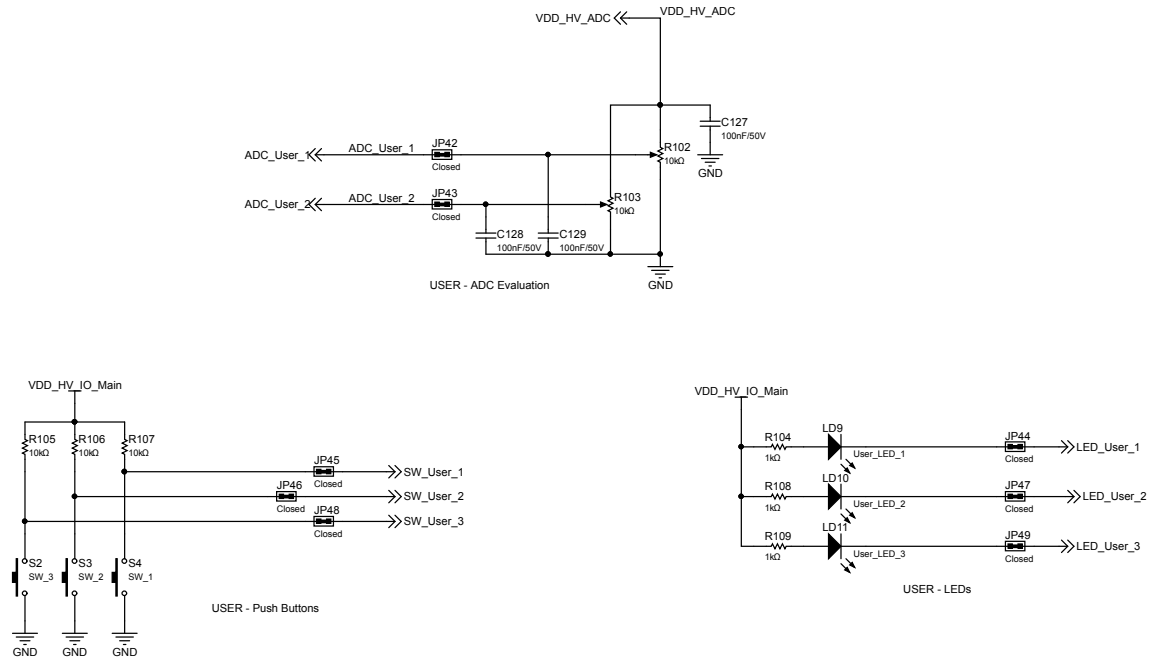

Figure 10. AEK-MCU-C4MLIT1 schematic - I/O connectors

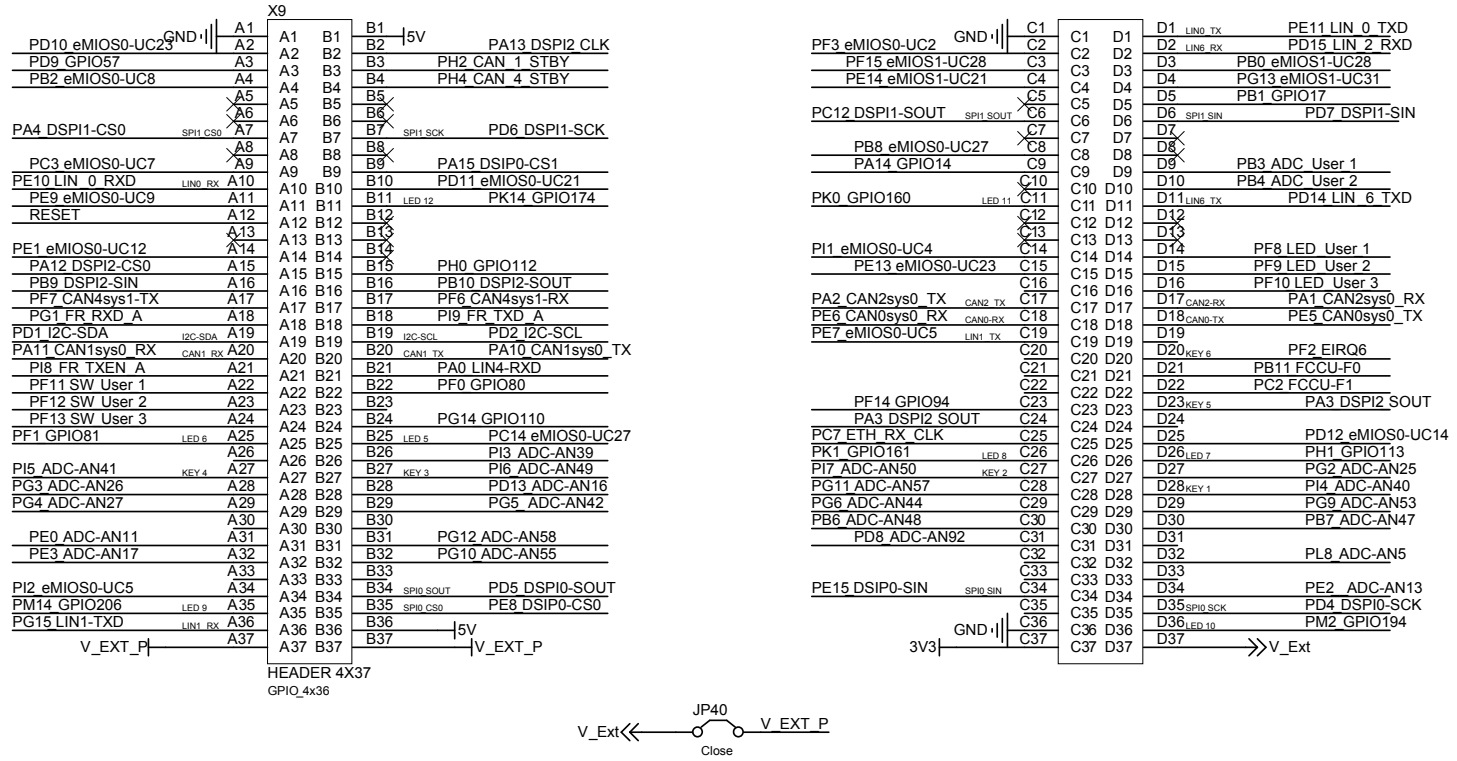

Figure 11. AEK-MCU-C4MLIT1 schematic - MCU power management

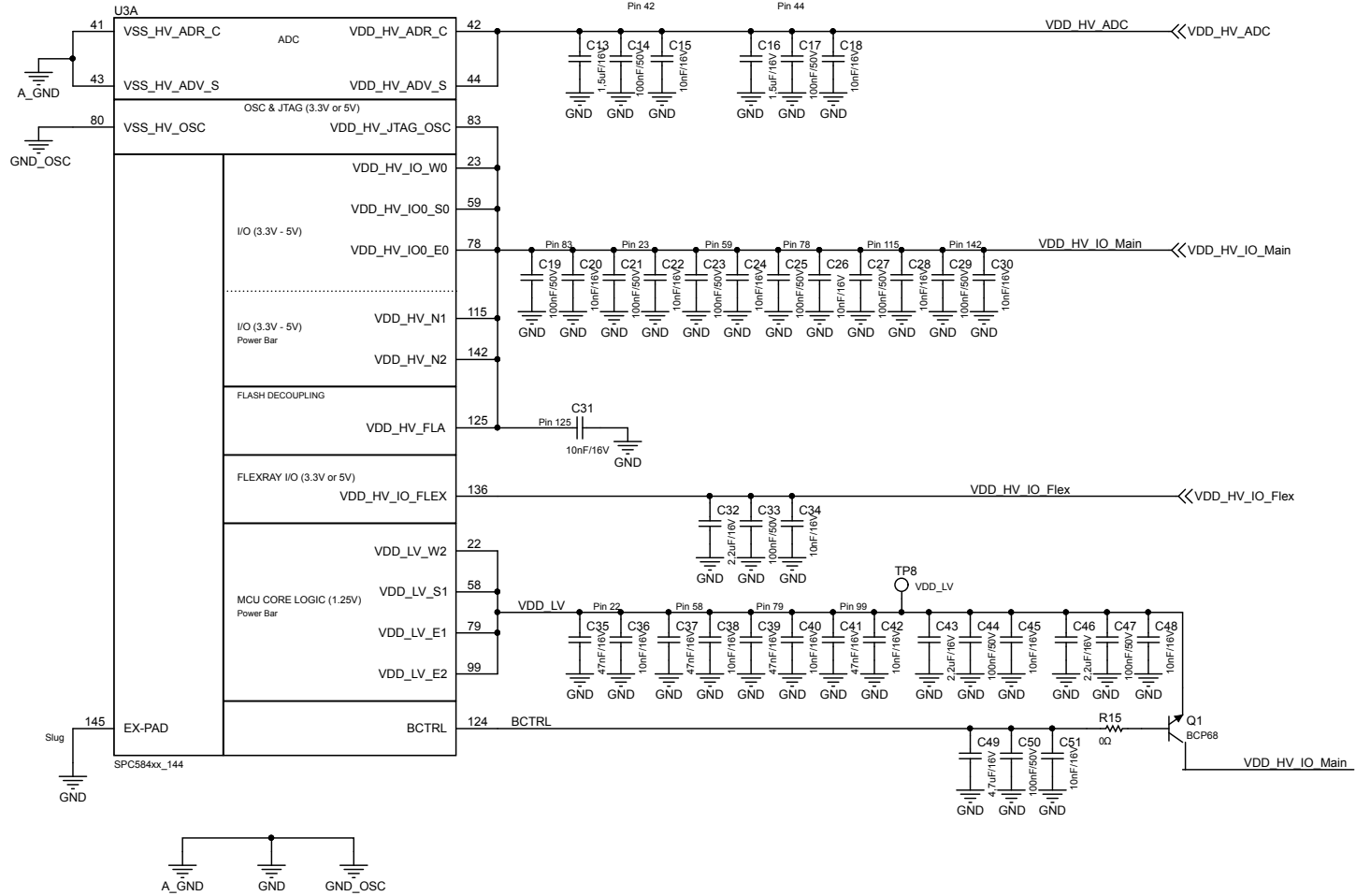
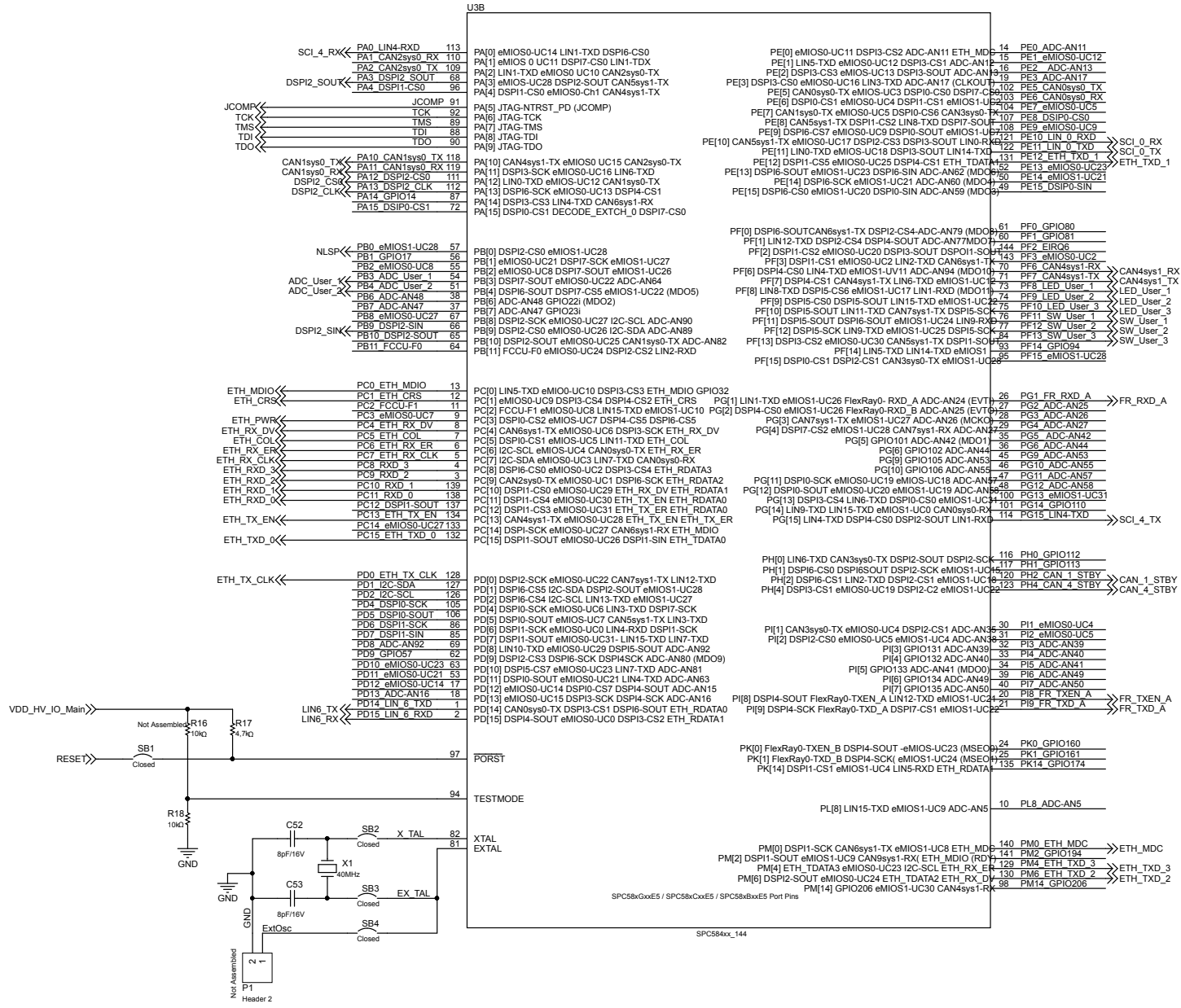
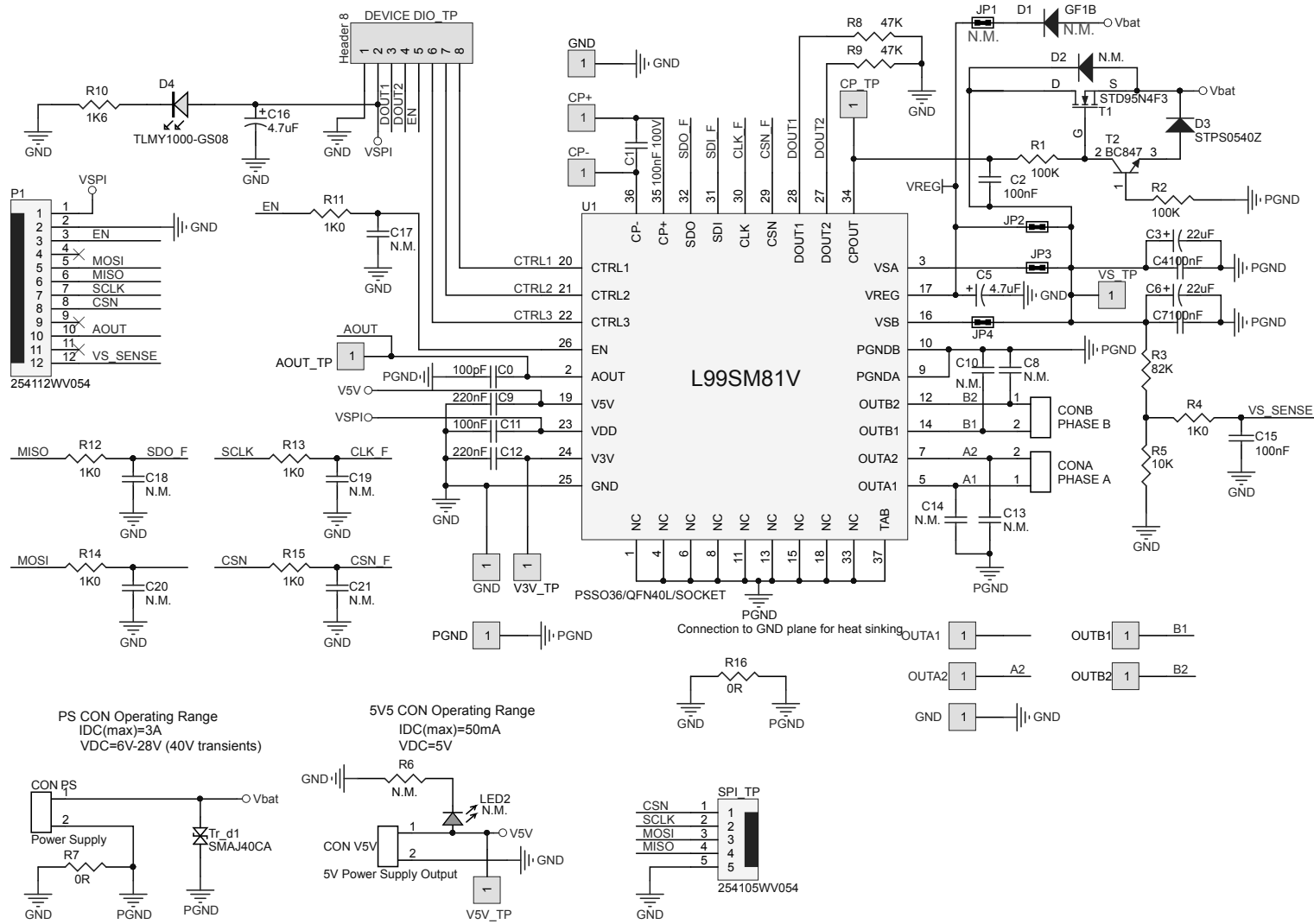

Figure 12. AEK-MCU-C4MLIT1 schematic - MCU I/O signals



3 AEK-MOT-SM81M1 schematic diagrams

Figure 13. AEK-MOT-SM81M1 schematic diagram



4 AEK-LED-21DISM1 schematic diagrams

Figure 14. AEK-LED-21DISM1 schematic - LED section

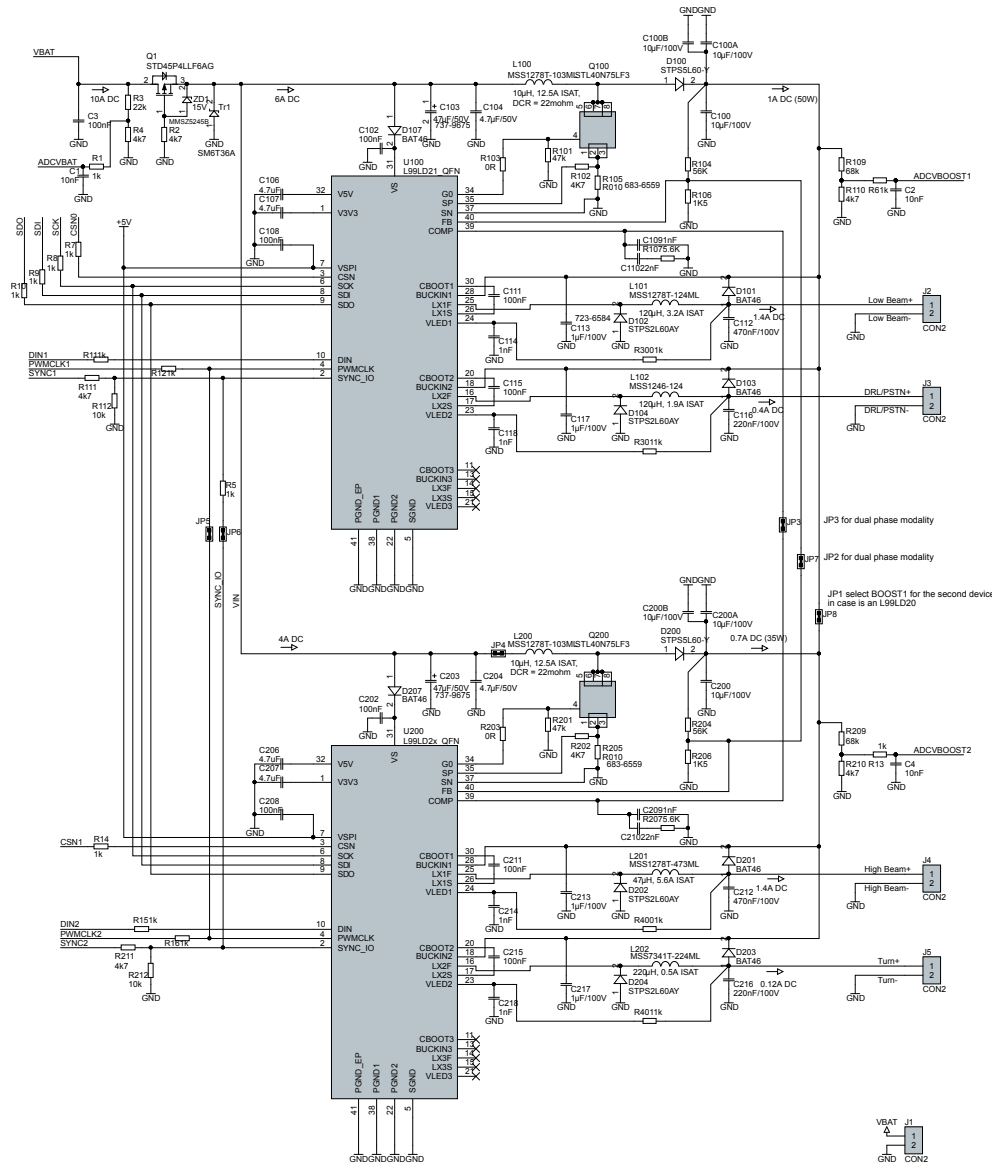
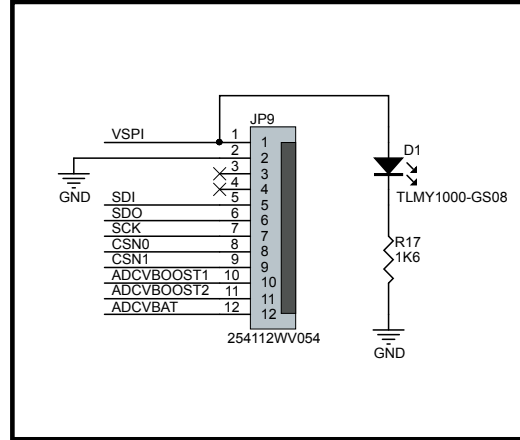
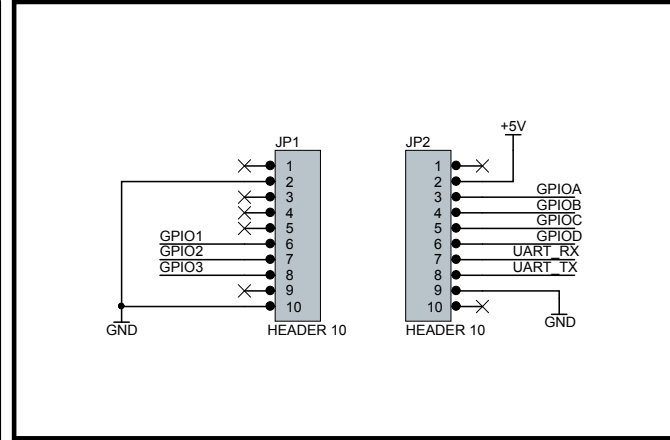

Figure 15. AEK-LED-21DISM1 schematic connectors

SPI & SIGNAL CONNECTOR



BLUETOOTH CONNECTORS



DISCOVERY CONNECTORS

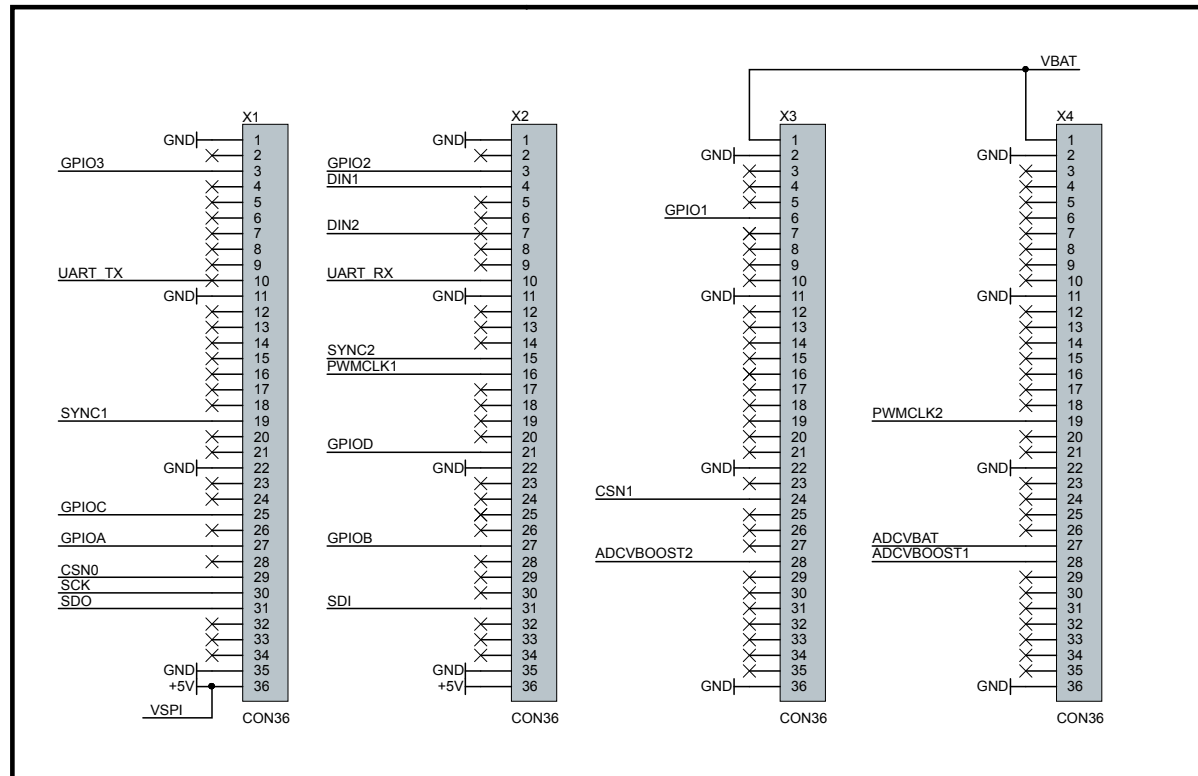

5 AEK-CON-5SLOTS1 schematic diagrams



Figure 16. AEK-CON-5SLOTS1 schematic diagrams

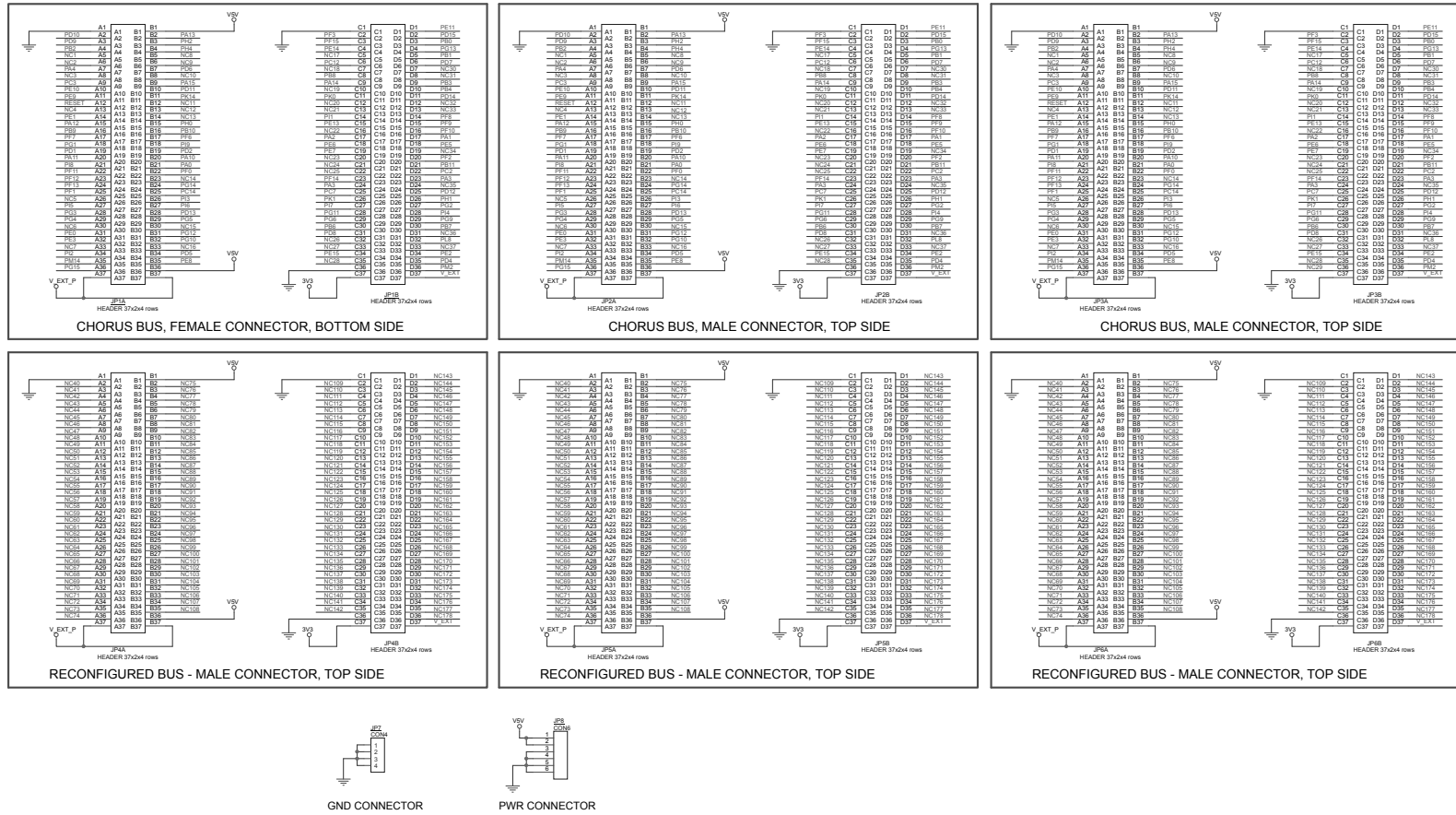

6 AEK-CON-AFLVIP2 schematic diagrams

Figure 17. AEK-CON-AFLVIP2 schematic diagrams (1 of 2)

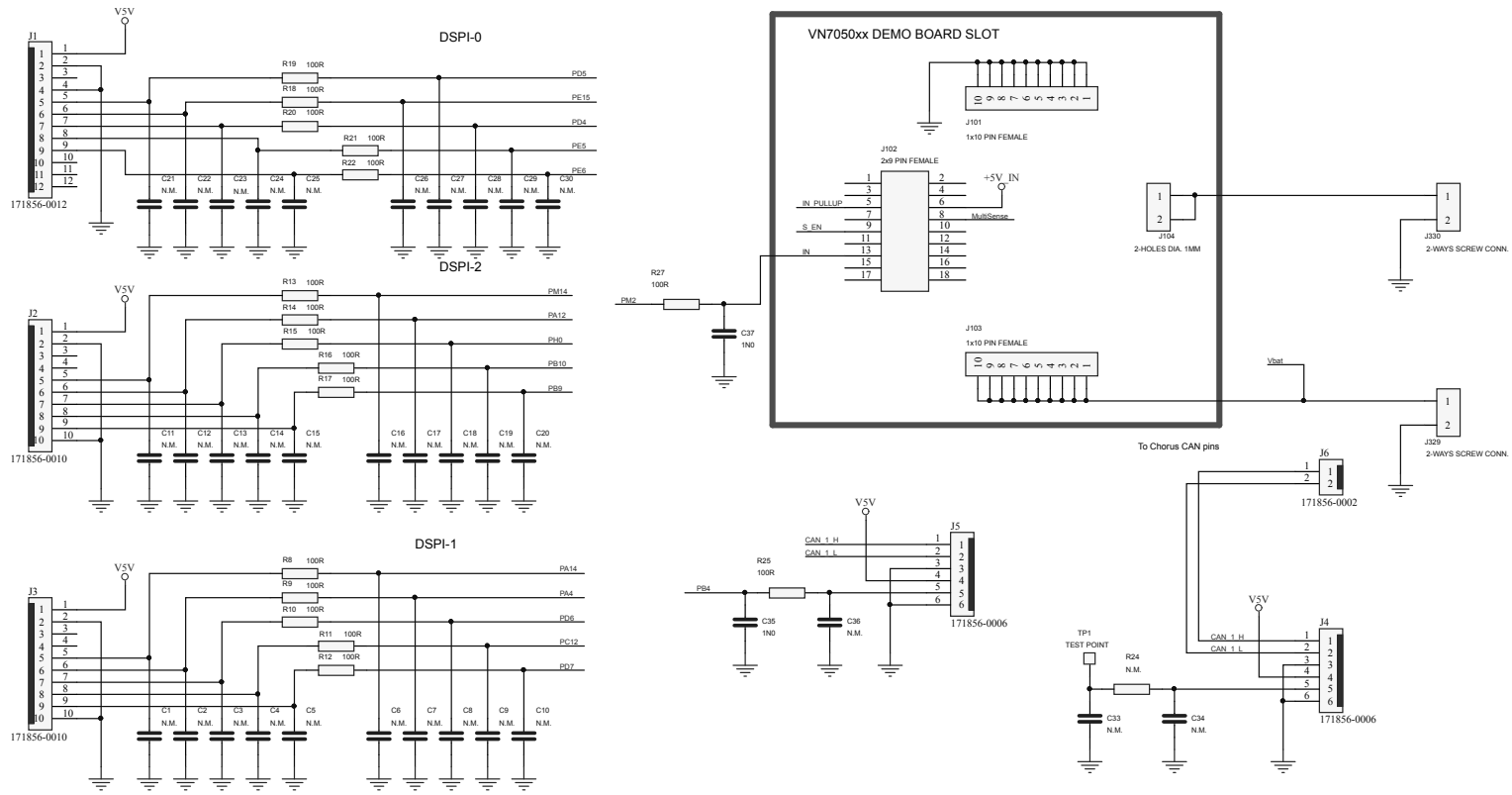
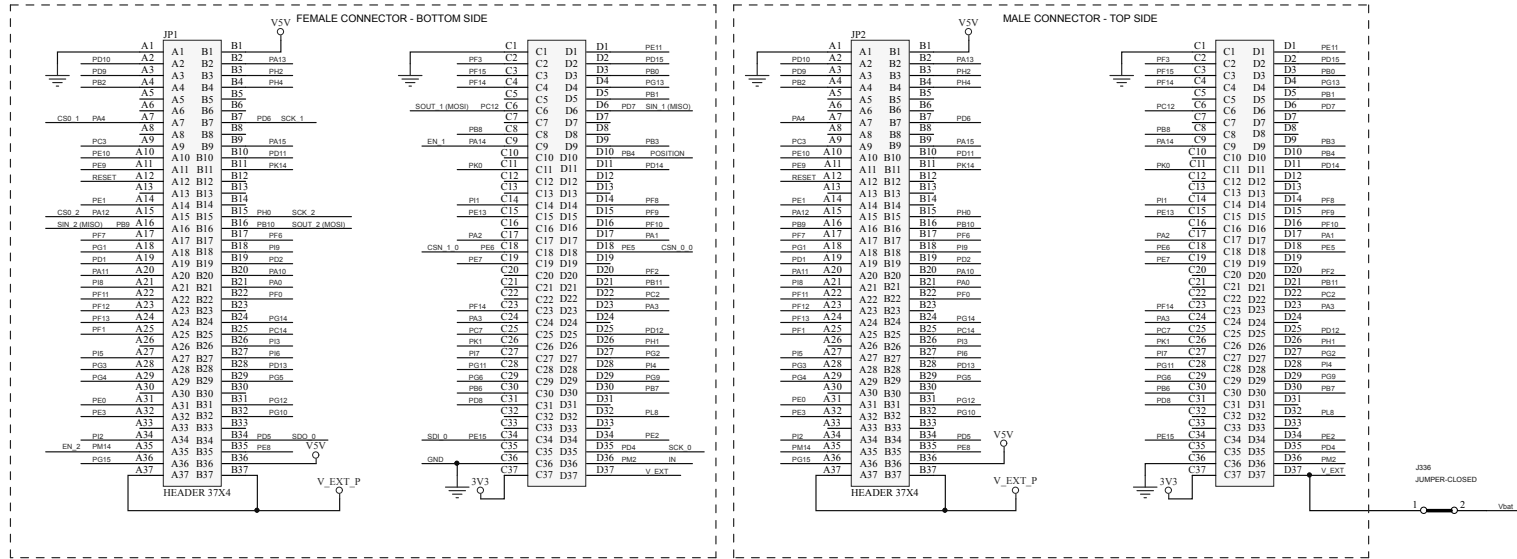

Figure 18. AEK-CON-AFLVIP2 schematic diagrams (2 of 2)



Revision history

Table 1. Document revision history

Date	Version	Changes
31-Jul-2019	1	Initial release.
19-Nov-2019	2	Updated front page image.

IMPORTANT NOTICE – PLEASE READ CAREFULLY

STMicroelectronics NV and its subsidiaries (“ST”) reserve the right to make changes, corrections, enhancements, modifications, and improvements to ST products and/or to this document at any time without notice. Purchasers should obtain the latest relevant information on ST products before placing orders. ST products are sold pursuant to ST’s terms and conditions of sale in place at the time of order acknowledgement.

Purchasers are solely responsible for the choice, selection, and use of ST products and ST assumes no liability for application assistance or the design of Purchasers’ products.

No license, express or implied, to any intellectual property right is granted by ST herein.

Resale of ST products with provisions different from the information set forth herein shall void any warranty granted by ST for such product.

ST and the ST logo are trademarks of ST. For additional information about ST trademarks, please refer to www.st.com/trademarks. All other product or service names are the property of their respective owners.

Information in this document supersedes and replaces information previously supplied in any prior versions of this document.

© 2019 STMicroelectronics – All rights reserved