

Introduction

The purpose of this application note is to illustrate how the Kionix KXTJ3 digital accelerometer can replace an existing Kionix KXTJ2 digital accelerometer.

Pin Compatibility

The KXTJ2 accelerometer can be easily replaced by a KXTJ3 digital accelerometer. The layout and pin compatibilities are identical and no hardware modifications are necessary.

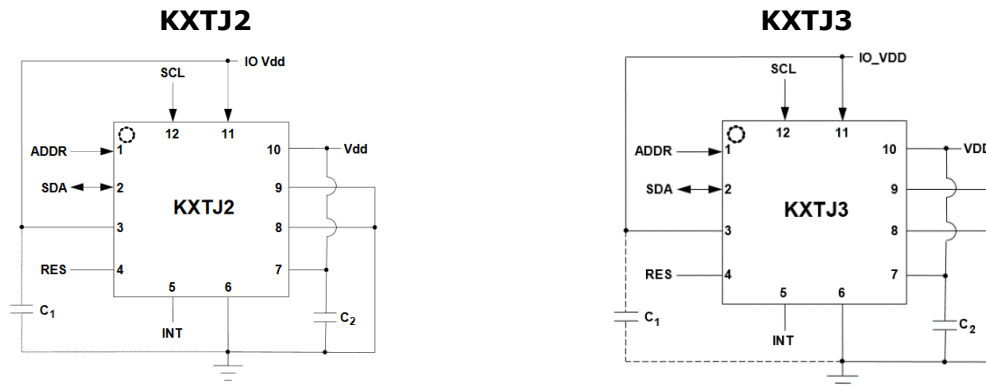

Pin	Name	Description
1	ADDR	I ² C programmable address bit – Connect to IO_VDD or GND
2	SDA	I ² C Serial Data
3	IO_VDD	The power supply input for the digital communication bus. Optionally decouple this pin to ground with a 0.1µF ceramic capacitor.
4	RES	Reserved – Connect to VDD, IO_VDD, or GND
5	INT	Physical Interrupt
6	GND	Ground
7	VDD	The power supply input. Decouple this pin to ground with a 0.1µF ceramic capacitor.
8	GND	Ground
9	GND	Ground
10	VDD	The power supply input. Decouple this pin to ground with a 0.1µF ceramic capacitor.
11	IO_VDD	The power supply input for the digital communication bus. Optionally decouple this pin to ground with a 0.1µF ceramic capacitor.
12	SCL	I ² C Serial Clock

Pin	Name	Description
1	ADDR	I ² C programmable address bit. Must be connected to IO_VDD or GND
2	SDA	I ² C Serial Data
3	IO_VDD ¹	The power supply input for the digital communication bus. Optionally decouple this pin to ground with a 0.1µF ceramic capacitor.
4	RES ⁴	Reserved. Connect to GND. Do not leave floating.
5	INT	Physical Interrupt pin. Leave floating if not used
6	GND ²	Ground
7	VDD ³	The power supply input. Decouple this pin to ground with a 0.1µF ceramic capacitor.
8	GND ²	Ground
9	GND ²	Ground
10	VDD ³	The power supply input. Decouple this pin to ground with a 0.1µF ceramic capacitor.
11	IO_VDD ¹	The power supply input for the digital communication bus. Optionally decouple this pin to ground with a 0.1µF ceramic capacitor.
12	SCL	I ² C Serial Clock

Figure 1: Pin Description KXTJ2 vs. KXTJ3

Additional Pin Specifications:

1. IO_VDD Pins 3 and 11 are internally tied together. For backwards compatibility with other parts, one of the two pins may be left floating.
2. GND Pins 6, 8, and 9 are internally tied together. For backwards compatibility with other parts, any two of the three pins may be left floating.
3. VDD Pins 7, and 10 are internally tied together. For backwards compatibility with other parts, one of the two pins may be left floating.
4. RES Pin 4 can be optionally tied to IO_VDD or VDD instead.

Key Differences

- CTRL_REG1
 - The KXTJ3 additionally offers a $\pm 16g$ range setting compared to KXTJ2 ($\pm 2g/\pm 4g/\pm 8g$). An additional bit (bit2) within the CTRL_REG1 register (0x1B) is used to control the range setting on the KXTJ3. When set, 16g range is configured, no matter what the GSEL bits are set to. Previously, on the KXTJ2, this bit was Reserved.
- WAKEUP_THRESHOLD
 - The KXTJ3 threshold for wake-up (motion detect) is now a 12-bit value to account for the addition of the $\pm 16g$ range, compared to KXTJ2's where it was only an 8-bit value.
 - The WAKEUP_THRESHOLD register also spans across two 8-bit registers, which are 0x6A (bit11-bit4) and 0x6B (bit7-bit4).
 - Additionally, the sensitivity for the threshold has changed from 62.5mg/count (KXTJ2) to 3.9mg/count (KXTJ3).
 - KXTJ2: $\text{WAKEUP_THRESHOLD (counts)} = \text{Desired Threshold (g)} \times 16 \text{ (counts/g)}$
 - KXTJ3: $\text{WAKEUP_THRESHOLD (counts)} = \text{Desired Threshold (g)} \times 256 \text{ (counts/g)}$
- NA_COUNTER
 - The KXTJ3 includes a new feature to set the non-activity time required before another wake-up interrupt can be set. The NA_COUNTER register (0x2A) is made available in the KXTJ3, but not KXTJ2.

The Kionix Advantage

Kionix technology provides inertial sensor system on a single, silicon chip, which is designed to strike a balance between current consumption and noise. A digital accelerometer can be used to enable a variety of simultaneous features including, but not limited to:

- Hard Disk Drive protection
- Vibration analysis
- Tilt screen navigation
- Sports modeling
- Theft, man-down, accident alarm
- Image stability, screen orientation & scrolling
- Computer pointer
- Navigation, mapping
- Game playing
- Automatic sleep mode
- Remote controls
- Toys

Theory of Operation

Kionix MEMS linear tri-axis accelerometers function on the principle of differential capacitance. Acceleration causes displacement of a silicon structure resulting in a change in capacitance. A signal-conditioning CMOS technology ASIC detects and transforms changes in capacitance into an analog output voltage, which is proportional to acceleration. These outputs can then be sent to a micro-controller for integration into various applications. For product summaries, specifications, and schematics, please refer to the Kionix MEMS accelerometer product sheets at <http://www.kionix.com/parametric/Accelerometers>.