

QSFP-100G-AOC3M-C

Cisco® QSFP-100G-AOC3M Compatible TAA Compliant 100GBase-AOC QSFP28 to QSFP28 Direct Attach Cable (850nm, MMF, 3m)

Features

- QSFP28 MSA compliant
- Four independent full-duplex channels
- Supports 103.1Gbps aggregate bit rate
- Up to 3m length
- Operating case temperature: 0°C to 70°C
- 4x25G electrical interface (OIF CEI-28G-VSR)
- Single 3.3V power supply
- Maximum power consumption 2.5W each terminal
- RoHS-6 compliant

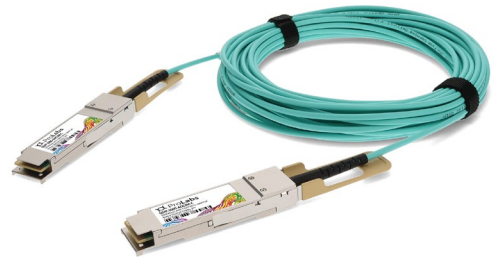

Applications

- 100G Ethernet
- InfiniBand EDR

Product Description

This is a Cisco® QSFP-100G-AOC3M compatible 100GBase-AOC QSFP28 to QSFP28 active optical cable that operates over multi-mode fiber with a maximum reach of 3.0m (9.8ft). At a wavelength of 850nm, it has been programmed, uniquely serialized, and data-traffic and application tested to ensure it is 100% compliant and functional. This active optical cable is TAA (Trade Agreements Act) compliant, and is built to comply with MSA (Multi-Source Agreement) standards. We stand behind the quality of our products and proudly offer a limited lifetime warranty.

ProLabs' active optical cables are RoHS compliant and lead free.

TAA refers to the Trade Agreements Act (19 U.S.C. & 2501-2581), which is intended to foster fair and open international trade. TAA requires that the U.S. Government may acquire only "U.S. – made or designated country end products."



Regulatory Compliance

- ESD to the Electrical PINs: compatible with MIL-STD-883 Method 3015.
- ESD to the Duplex LC Receptacle: compatible with IEC 61000-4-2.
- Immunity: compatible with IEC 61000-4-3.
- EMI: compatible with FCC Part 15 Class B EN55022 Class B (CISPR 22B) VCCI Class B.
- Laser Eye Safety: compatible with FDA 21CFR 1040.10 and 1040.11 EN60950, EN (IEC) 60825-1, 2.
- RoHS: compliant with 2002/95/EC 4.1&4.2 2005/747/EC.

Absolute Maximum Ratings

Parameter	Symbol	Min	Typ.	Max.	Unit
Storage Temperature	Tstg	-40		85	°C
Operating Case Temperature	Top	0		70	
Power Supply Voltage	Vcc	-0.5		3.6	V
Relative Humidity (non-condensation)	RH	0		85	%

Recommended Operating Conditions and Power Supply Requirements

Parameter	Symbol	Min	Typ.	Max.	Unit
Power Supply Voltage	Vcc	3.135	3.3	3.465	V
Data Rate, each Lane			25.78125		Gbps
Data Rate Accuracy		-100		100	ppm
Control Input Voltage High		2		Vcc	V
Control Input Voltage Low		0		0.8	V

Electrical Characteristics

Parameter	Test Point	Min.	Typical	Max	Units	Notes
Power Consumption				2.5	W	1
Supply Current	I _{cc}			757	mA	1
Transmitter (each lane)						
Overload Differential Voltage	TP1a	900			mV	
Common Mode Voltage (V _{cm})	TP1	-350		2825	mV	2
Differential Termination Resistance Mismatch	TP1			10	%	At 1MHz
Differential Return Loss (SDD11)	TP1			See CEI-28GOVSR Equation 13-19	dB	
Common Mode to Differential conversion and Differential to Common Mode conversion	TP1			See CEI-28G-VSR Equation 13-20	dB	
Stressed Input Test	TP1a	See CEI-28G-VSR Section 13.3.11.2.1				
Receiver (each lane)						
Differential Voltage, pk-pk	TP4			900	mV	
Common Mode Voltage (V _{cm})	TP4	-350		2850	mV	2
Common Mode Noise, RMS	TP4			17.5	mV	
Differential Termination Resistance Mismatch	TP4			10	%	At 1MHz
Differential Return Loss (SDD22)	TP4			See CEI-28G-VSR Equation 13-19	dB	
Common Mode to Differential conversion and Differential to Common Mode conversion (SCC22)	TP4			-2	dB	3
Transition Time, 20 to 80%	TP4	9.5			Ps	
Vertical Eye Closure (VEC)	TP4			5.5	dB	
Eye Width at 10 ⁻¹⁵ Probability (EW15)	TP4	0.57			UI	
Eye Height at 10-15 Probability (EH15)	TP4	0.57			UI	

Notes:

1. Per terminal.
2. V_{cm} is generated by the host. Specification includes effects of ground offset voltage.
3. From 250MHz to 30GHz.

Pin Descriptions

Pin	Logic	Symbol	Name/Descriptions	Ref.
1		GND	Module Ground.	1
2	CML-I	Tx2-	Transmitter inverted data input.	
3	CML-I	Tx2+	Transmitter non-inverted data input.	
4		GND	Module Ground.	1
5	CML-I	Tx4-	Transmitter inverted data input.	
6	CML-I	Tx4+	Transmitter non-inverted data input.	
7		GND	Module Ground.	1
8	LVTTTL-I	MODSEIL	Module Select.	2
9	LVTTTL-I	ResetL	Module Reset.	2
10		VCCRx	+3.3V Receiver Power Supply.	
11	LVCNOS-I	SCL	2-wire Serial interface clock.	2
12	LVCNOS-I/O	SDA	2-wire Serial interface data.	2
13		GND	Module Ground.	1
14	CML-O	RX3+	Receiver non-inverted data output.	
15	CML-O	RX3-	Receiver inverted data output.	
16		GND	Module Ground.	1
17	CML-O	RX1+	Receiver non-inverted data output.	
18	CML-O	RX1-	Receiver inverted data output.	
19		GND	Module Ground.	1
20		GND	Module Ground.	1
21	CML-O	RX2-	Receiver inverted data output.	
22	CML-O	RX2+	Receiver non-inverted data output.	
23		GND	Module Ground.	1
24	CML-O	RX4-	Receiver inverted data output.	
25	CML-O	RX4+	Receiver non-inverted data output.	
26		GND	Module Ground.	1
27	LVTTTL-O	ModPrsL	Module Present, internal pulled down to GND.	
28	LVTTTL-O	IntL	Interrupt output should be pulled up on host board.	2
29		VCCTx	+3.3V Transmitter Power Supply.	
30		VCC1	+3.3V Power Supply.	
31	LVTTTL-I	LPMode	Low Power Mode.	2
32		GND	Module Ground.	1
33	CML-I	Tx3+	Transmitter non-inverted data input.	
34	CML-I	Tx3-	Transmitter inverted data input.	
35		GND	Module Ground.	1
36	CML-I	Tx1+	Transmitter non-inverted data input.	
37	CML-I	Tx1-	Transmitter inverted data input.	
38		GND	Module Ground.	1

Notes:

1. Module circuit ground is isolated from module chassis ground with in the module.
2. Open collector; should be pulled up with 4.7k-10k ohms on host board to a voltage between 3.15V and 3.6V.

Electrical Pin-out Details

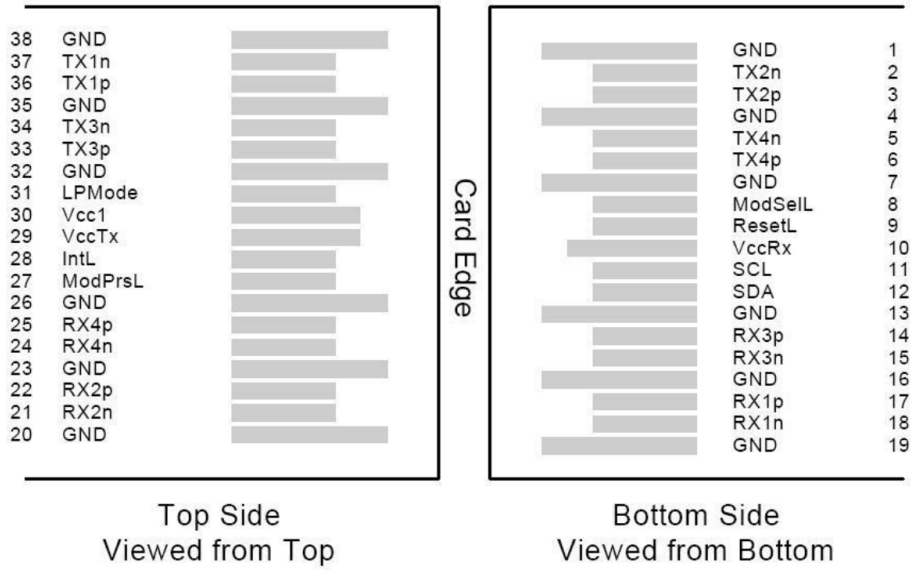

Recommended Power Supply Filter

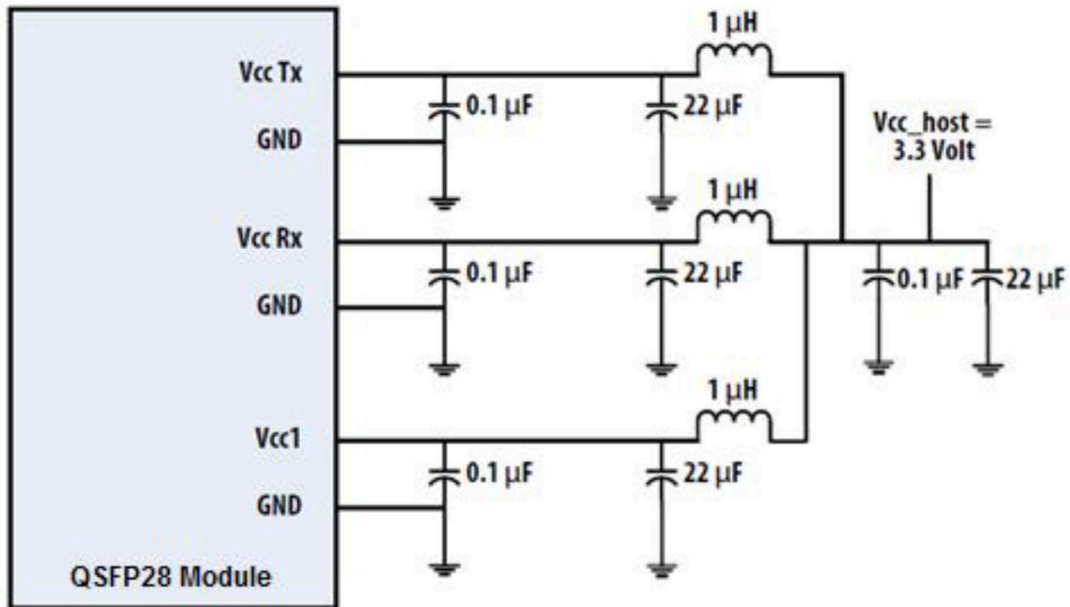

AOC Block Diagram

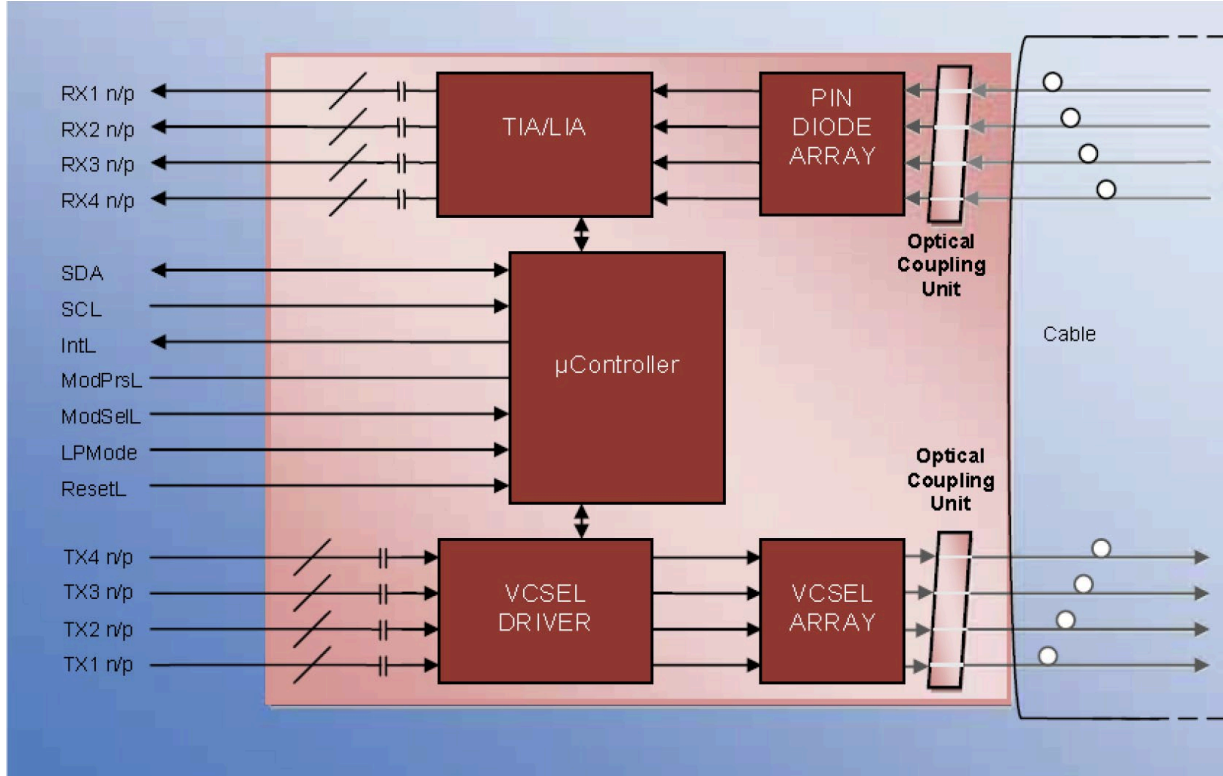

Mechanical Specification

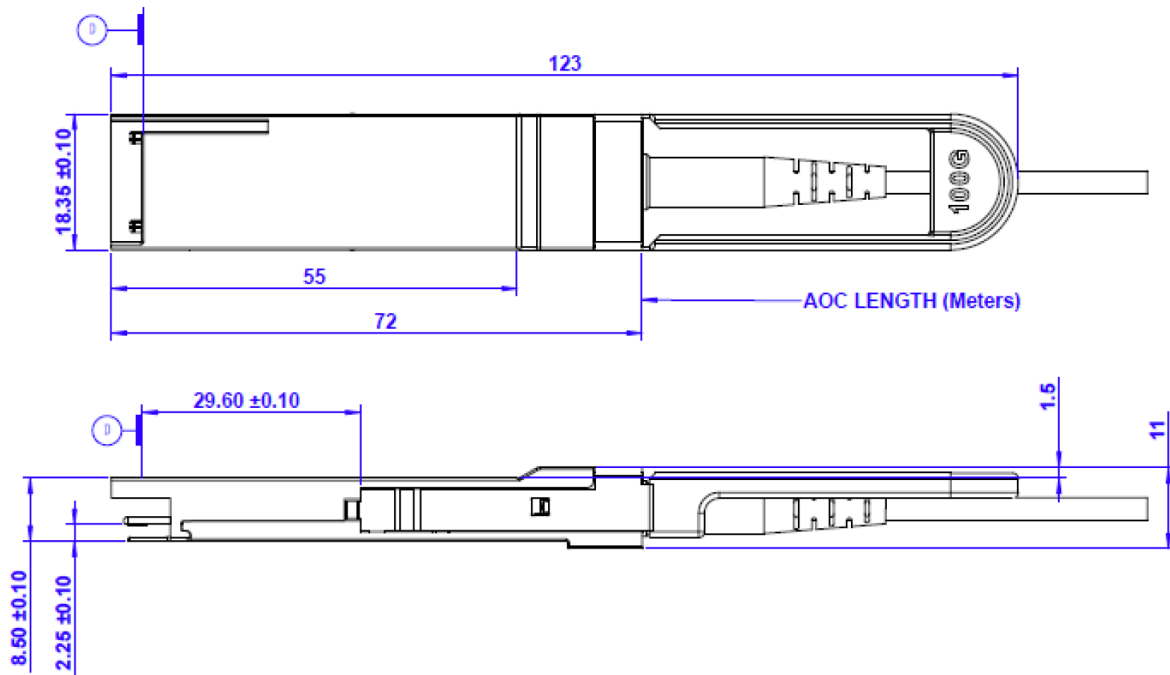

About ProLabs

Our experience comes as standard; for over 15 years ProLabs has delivered optical connectivity solutions that give our customers freedom and choice through our ability to provide seamless interoperability. At the heart of our company is the ability to provide state-of-the-art optical transport and connectivity solutions that are compatible with over 90 optical switching and transport platforms.

Complete Portfolio of Network Solutions

ProLabs is focused on innovations in optical transport and connectivity. The combination of our knowledge of optics and networking equipment enables ProLabs to be your single source for optical transport and connectivity solutions from 100Mb to 400G while providing innovative solutions that increase network efficiency. We provide the optical connectivity expertise that is compatible with and enhances your switching and transport equipment.

Trusted Partner

Customer service is our number one value. ProLabs has invested in people, labs and manufacturing capacity to ensure that you get immediate answers to your questions and compatible product when needed. With Engineering and Manufacturing offices in the U.K. and U.S. augmented by field offices throughout the U.S., U.K. and Asia, ProLabs is able to be our customers best advocate 24 hours a day.

Contact Information

ProLabs US

Email: sales@prolabs.com

Telephone: 952-852-0252

ProLabs UK

Email: salessupport@prolabs.com

Telephone: +44 1285 719 600