

DO NOT SCALE FROM THIS PRINT

DESIGNED & DIMENSIONED IN INCHES[MILLIMETERS]

SIR1-XX-X-S-X-X-XX

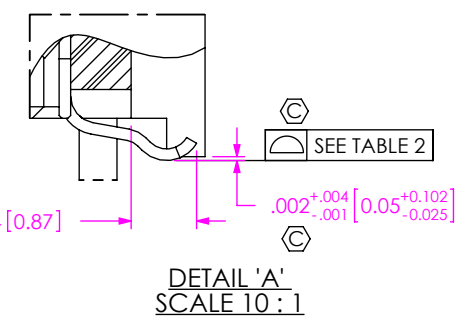
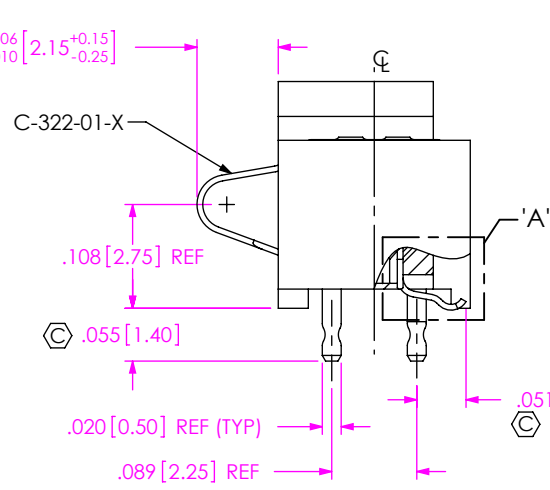
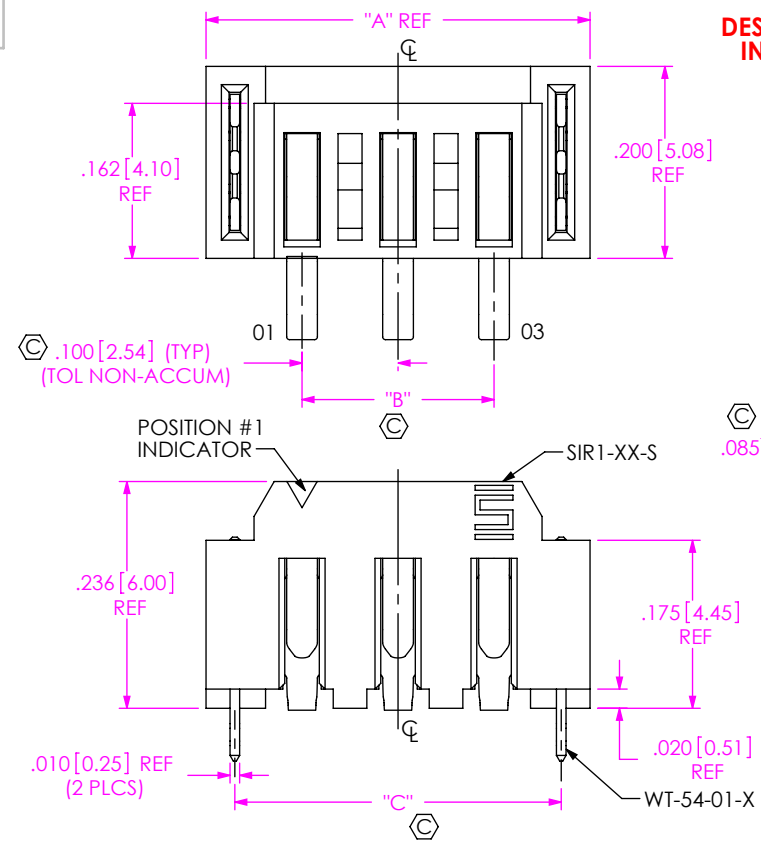

DETAIL 'A' SCALE 10:1

FIG 1 SIR1-03-X-S SHOWN

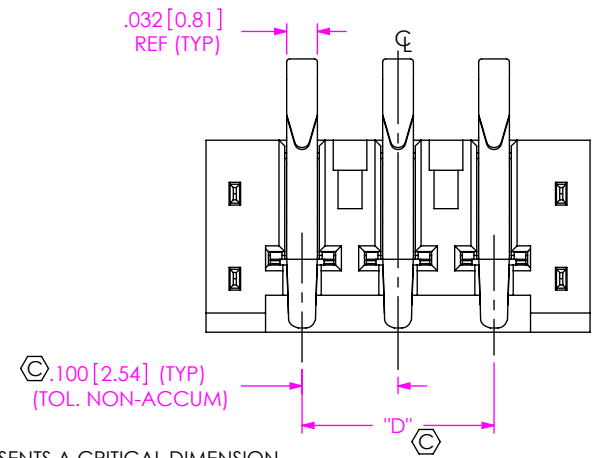

NOTES:

1. Ⓢ REPRESENTS A CRITICAL DIMENSION.
2. MAXIMUM BURR ALLOWANCE: .0015[0.038]
3. MINIMUM PUSHOUT FORCE: .5 LB[2.2 N]
4. LOAD INSERTS IN DIRECTION OF THE ARROW USING HAND LOAD THERMAL INSERTION PRESS.
5. THREADED INSERT MUST BE ABLE TO HANDLE 20 in-oz's OF TORQUE MIN WITHOUT ROTATING OR "LOOSENING".
6. THREADED INSERT RETENSION TO BE 7lbs. MIN.
7. THREADED INSERT TO BE FLUSH TO .005[0.13] BELOW HOUSING SURFACE.
8. NOTE DELETED.
9. ASSEMBLIES TO BE PACKAGED IN TUBES, UNLESS -TR IS SPECIFIED.

No OF POSITIONS
-03, -05, -07, -10, -15,
*20, *25, *30
(PER ROW)

PLATING SPECIFICATION
-L: 10μ" GOLD IN CONTACT AREA,
MATTE TIN ON TAIL
-S: 30μ" GOLD IN CONTACT AREA,
MATTE TIN ON TAIL

ROW SPECIFICATION
-S: SINGLE ROW

(* = NOT TOOLED)

PACKAGING
-TR: TAPE & REEL FOR OPTIONAL

OPTION
-A: ALIGNMENT PIN
(USE SIR1-XX-A-X)
-K: POLYAMIDE FILM
(USE K-DOT-.157-.250-.005,
SEE FIG. 3, SHT 2)

THREADED INSERT OPTION
*E: THREADED INSERT (ENGLISH)
(USE INS-14-2-56-115.)
*M: THREADED INSERT (METRIC)
(USE INS-14-M2-115-N)

No. OF POS	COPLANARITY
-03, -05, -07, -10, -15	.0040 [0.102]
*20, *25, & *30	.0060 [0.152]

(* = NOT TOOLED)

No. OF POS	"A"	"B"	"C"	"D"	"E"	"F"	"G"
-03	.400 [10.16]	.2000 [5.080]	.340 [8.64]	.2000 [5.080]	N/A	N/A	N/A
-05	.600 [15.24]	.4000 [10.160]	.540 [13.72]	.4000 [10.160]	N/A	N/A	N/A
-07	.800 [20.32]	.6000 [15.240]	.740 [18.80]	.6000 [15.240]	N/A	N/A	N/A
-10	1.100 [27.94]	.9000 [22.860]	1.040 [26.42]	.9000 [22.860]	N/A	N/A	N/A
-15	1.600 [40.64]	1.4000 [35.560]	1.540 [39.12]	1.4000 [35.560]	N/A	N/A	N/A
*20	2.200 [55.88]	2.0000 [50.800]	2.140 [54.36]	2.0000 [50.800]	1.0700 [27.178]	1.1000 [27.940]	.9000 [22.860]
*25	2.700 [68.58]	2.5000 [63.500]	2.640 [67.06]	2.5000 [63.500]	1.3700 [34.798]	1.4000 [35.560]	1.2000 [30.480]
*30	3.200 [81.28]	3.0000 [76.200]	3.140 [79.76]	3.0000 [76.200]	1.5700 [39.878]	1.6000 [40.640]	1.4000 [35.560]

UNLESS OTHERWISE SPECIFIED, DIMENSIONS ARE IN INCHES.

TOLERANCES ARE:
DECIMALS ANGLES
.XX: ±.01[0.3] 2°
.XXX: ±.005[0.13]
.XXXX: ±.0020[0.051]

PROPRIETARY NOTE
THIS DOCUMENT CONTAINS CONFIDENTIAL AND PROPRIETARY INFORMATION AND ALL DESIGN, MANUFACTURING, REPRODUCTION, USE, PATENT RIGHTS AND SALES RIGHTS ARE EXPRESSLY RESERVED BY SAMTEC, INC. THIS DOCUMENT SHALL NOT BE DISCLOSED, IN WHOLE OR PART, TO ANY UNAUTHORIZED PERSON OR ENTITY NOR REPRODUCED, TRANSFERRED OR INCORPORATED IN ANY OTHER PROJECT IN ANY MANNER WITHOUT THE EXPRESS WRITTEN CONSENT OF SAMTEC, INC.

MATERIAL: DO NOT SCALE DRAWING SHEET SCALE: 5:1
INSULATOR: LCP, COLOR: BLACK
CONTACT: PHOS BRONZE
WELD TAB: PHOS BRONZE

DESCRIPTION:
ONE PIECE POWER RIGHT ANGLE ASSEMBLY

DWG. NO. SIR1-XX-X-S-X-X-XX

BY: ROY LUO 5/20/2010 SHEET 1 OF 4

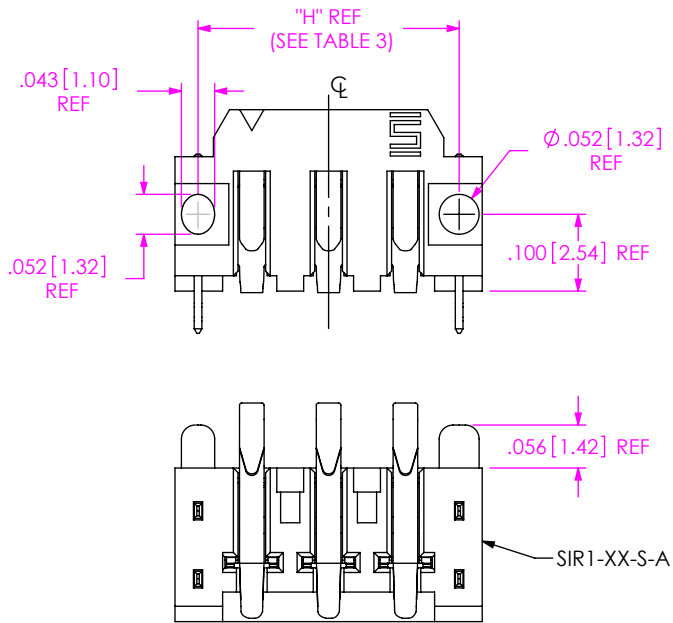

FIG 2
(SIR1-03-X-S-A SHOWN)
(SAME AS FIG 1, EXCEPT AS SHOWN)

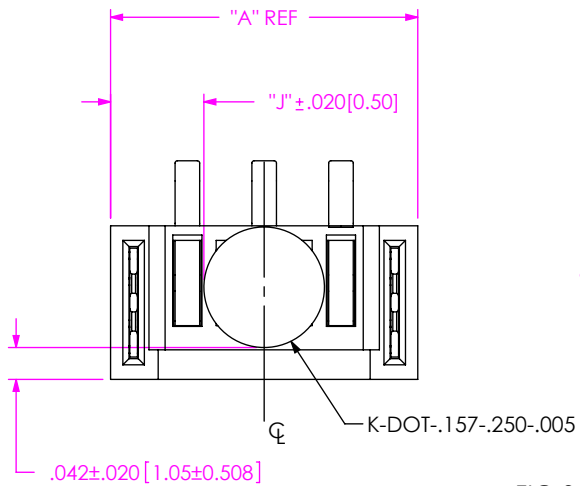
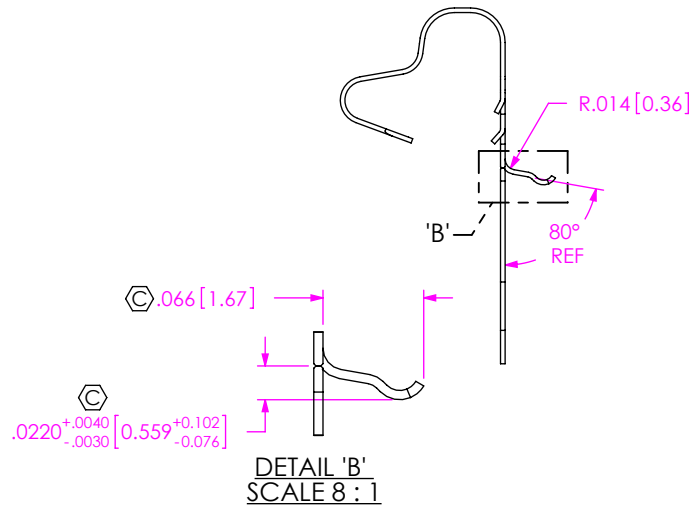
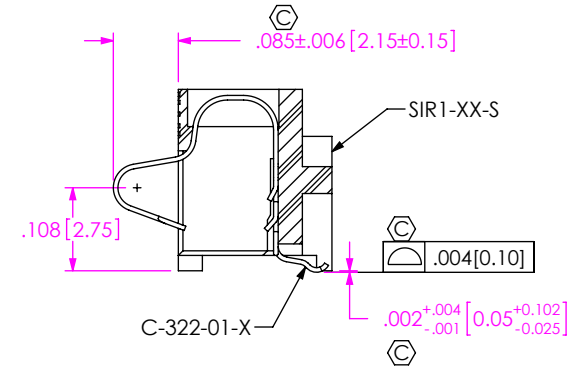

FIG 3
(SIR1-03-X-S-K SHOWN)
(SAME AS FIG 1, EXCEPT AS SHOWN)



IN-PROCESS 1
(FORM CONTACT C-322-01-X)



IN-PROCESS 2
(FILL CONTACT C-322-01-X)

TABLE 3

No. OF POS	"H"	"J"
-03	.3400 [8.636]	.122 [3.10]
-05	.5400 [13.716]	.222 [5.64]
-07	.7400 [18.796]	.322 [8.18]
-10	1.0400 [26.416]	.472 [11.99]
-15	1.5400 [39.116]	.722 [18.34]
*-20	2.1400 [54.356]	1.022 [25.96]
*-25	2.6400 [67.056]	1.272 [32.31]
*-30	3.1400 [79.756]	1.522 [38.66]

(* = NOT TOOLED)

PROPRIETARY NOTE
THIS DOCUMENT CONTAINS CONFIDENTIAL AND PROPRIETARY INFORMATION AND ALL DESIGN, MANUFACTURING, REPRODUCTION, USE, PATENT RIGHTS AND SALES RIGHTS ARE EXPRESSLY RESERVED BY SAMTEC, INC. THIS DOCUMENT SHALL NOT BE DISCLOSED, IN WHOLE OR PART, TO ANY UNAUTHORIZED PERSON OR ENTITY NOR REPRODUCED, TRANSFERRED OR INCORPORATED IN ANY OTHER PROJECT IN ANY MANNER WITHOUT THE EXPRESS WRITTEN CONSENT OF SAMTEC, INC.

DO NOT SCALE DRAWING

SHEET SCALE: 4:1



520 PARK EAST BLVD, NEW ALBANY, IN 47150
PHONE: 812-944-6733 FAX: 812-948-5047
e-Mail info@SAMTEC.com code 55322

DESCRIPTION:
ONE PIECE POWER RIGHT ANGLE ASSEMBLY

DWG. NO.
SIR1-XX-X-S-X-X-XX

BY: ROY LUO 5/20/2010 SHEET 2 OF 4

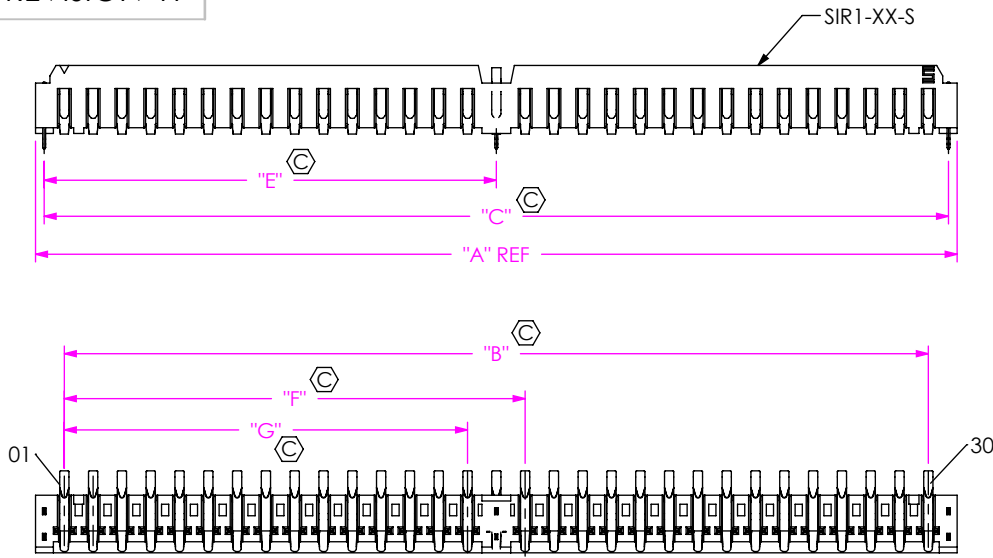

FIG 4
(SIR1-30-X-S SHOWN)
(SAME AS FIG 1, EXCEPT AS SHOWN)
(FOR POSITIONS -20, -25, & -30)
(NOT TOOLED)

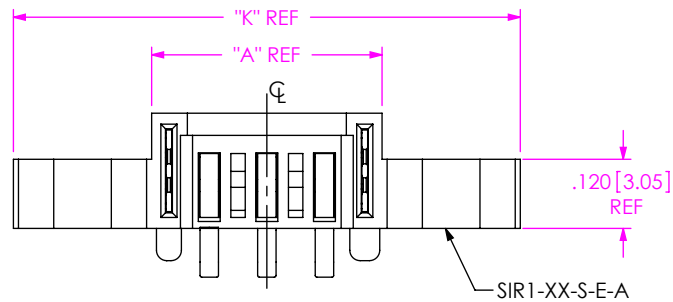
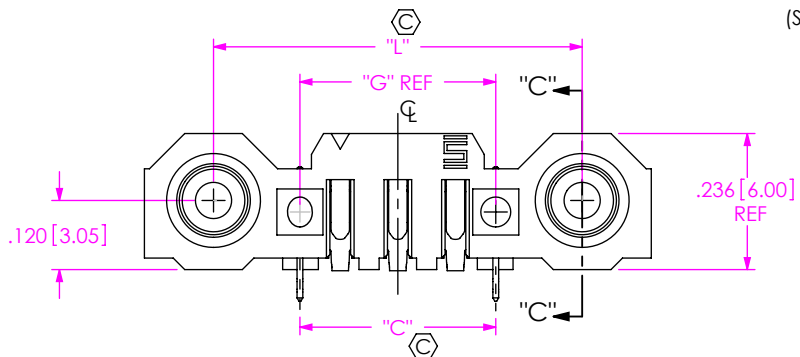

FIG 5
-E & -M OPTION
(SIR1-03-X-S-X-A SHOWN)
(SAME AS FIG 2, EXCEPT AS SHOWN)
(NOT TOOLED)



F:\DWG\MISC\MKTG\SIR1-XX-X-S-X-XX-MKT.SLDDRW

No. OF POS	"K"	"L"
-03	.880 [22.352]	.640 [16.26]
-05	1.080 [27.432]	.840 [21.34]
-07	1.280 [32.512]	1.040 [26.42]
-10	1.580 [40.132]	1.340 [34.04]
-15	2.080 [52.832]	1.840 [46.74]
-20	2.680 [68.072]	2.440 [61.98]
-25	3.180 [80.772]	2.940 [74.68]
-30	3.680 [93.472]	3.440 [87.38]

OPTION	THREADED INSERT
-E	INS-14-2-56-115
**M	INS-14-M2-115-N

** = METRIC THREADED INSERTS
TO BE FLASH NICKEL PLATED

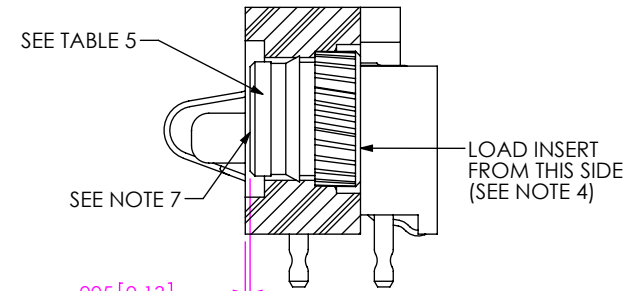

SECTION "C"-"C"
SCALE 5:1

PROPRIETARY NOTE
THIS DOCUMENT CONTAINS CONFIDENTIAL AND PROPRIETARY INFORMATION AND ALL DESIGN, MANUFACTURING, REPRODUCTION, USE, PATENT RIGHTS AND SALES RIGHTS ARE EXPRESSLY RESERVED BY SAMTEC, INC. THIS DOCUMENT SHALL NOT BE DISCLOSED, IN WHOLE OR PART, TO ANY UNAUTHORIZED PERSON OR ENTITY NOR REPRODUCED, TRANSFERRED OR INCORPORATED IN ANY OTHER PROJECT IN ANY MANNER WITHOUT THE EXPRESS WRITTEN CONSENT OF SAMTEC, INC.

DO NOT SCALE DRAWING

SHEET SCALE: 3:1

samtec

520 PARK EAST BLVD. NEW ALBANY, IN 47150
PHONE: 812-944-6733 FAX: 812-948-5047
e-Mail info@SAMTEC.com code 55322

DESCRIPTION:
ONE PIECE POWER RIGHT ANGLE ASSEMBLY

DWG. NO.
SIR1-XX-X-S-X-X-XX

BY: ROY LUO 5/20/2010 SHEET 3 OF 4

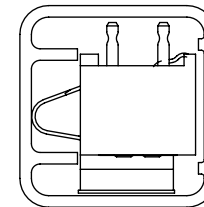

PACKAGING VIEW
 TUBE: PT-1-24-11-63
 PLUG: TP-09

<p>PROPRIETARY NOTE</p> <p>THIS DOCUMENT CONTAINS CONFIDENTIAL AND PROPRIETARY INFORMATION AND ALL DESIGN, MANUFACTURING, REPRODUCTION, USE, PATENT RIGHTS AND SALES RIGHTS ARE EXPRESSLY RESERVED BY SAMTEC, INC. THIS DOCUMENT SHALL NOT BE DISCLOSED, IN WHOLE OR PART, TO ANY UNAUTHORIZED PERSON OR ENTITY NOR REPRODUCED, TRANSFERRED OR INCORPORATED IN ANY OTHER PROJECT IN ANY MANNER WITHOUT THE EXPRESS WRITTEN CONSENT OF SAMTEC, INC.</p>	 <p>520 PARK EAST BLVD, NEW ALBANY, IN 47150 PHONE: 812-944-6733 FAX: 812-948-5047 e-Mail info@SAMTEC.com code 55322</p>
<p>DO NOT SCALE DRAWING</p> <p>SHEET SCALE: 3:1</p>	<p>DESCRIPTION: ONE PIECE POWER RIGHT ANGLE ASSEMBLY</p> <p>DWG. NO. SIR1-XX-X-S-X-X-XX</p> <p>BY: ROY LUO 5/20/2010 SHEET 4 OF 4</p>