

| REVISIONS | | | | |
|-----------|-----|---------------------------|-----------|----------|
| P. | LTN | DESCRIPTION | DATE | OWN APVD |
| C | | REVISED PER ECO-16-005492 | 11APR2016 | DLD WEM |
| C1 | | REVISED PER ECO-16-010315 | 12JUL2016 | DLD WEM |
| C2 | | REVISED PER ECO-17-010568 | 20JUL2017 | RGV GM |
| C3 | | REVISED PER ECO-19-009349 | 21JUN2019 | JMS HC |

LEVER IN LOCKED POSITION

WIRE COVER ASSEMBLY PART NUMBER 1924779-1 MUST BE PURCHASED SEPARATELY

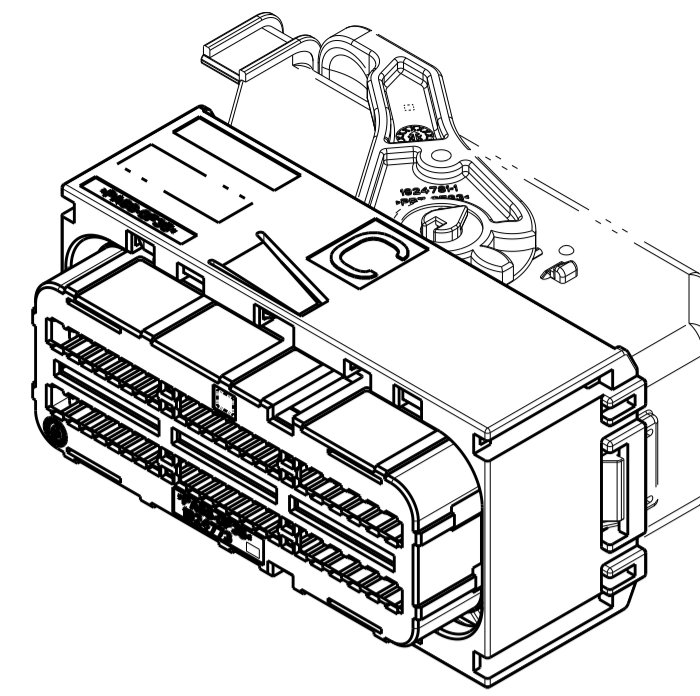
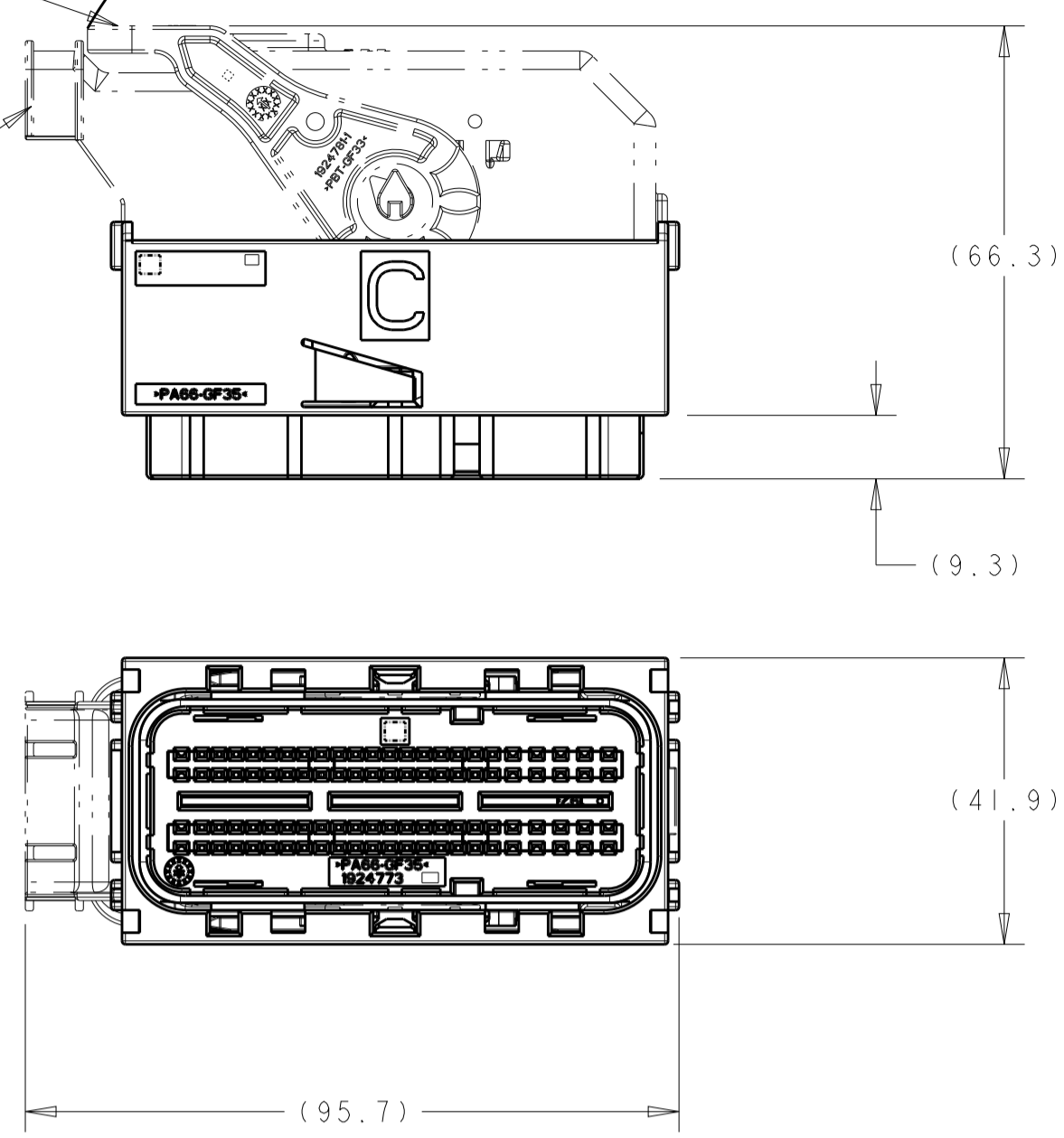

ISOMETRIC VIEW SCALE 1:1

LEFT EXIT PLUG ASSEMBLY SHOWN WITH OPTIONAL WIRE COVER ASSEMBLY (MUST BE PURCHASED SEPARATELY) SCALE 1:1

ACCEPTS 20-16 AWG; 0.5mm²-1.5mm² TERMINALS (USE A WIRE INSULATION O.D. RANGE OF 1.40 TO 2.40mm)

POSITION 24 REF

POSITION 96 REF

ACCEPTS 20-16AWG; 0.5mm²-1.5mm² TERMINALS (USE A WIRE INSULATION O.D. RANGE OF 1.40 TO 2.40mm)

POSITION 1 REF

COMPANY LOGO

POSITION 73 REF

ACCEPTS 22-18AWG; 0.35mm²-0.75mm² TERMINALS (USE A WIRE INSULATION O.D. RANGE OF 1.20 TO 2.06mm)

2X (7.35)

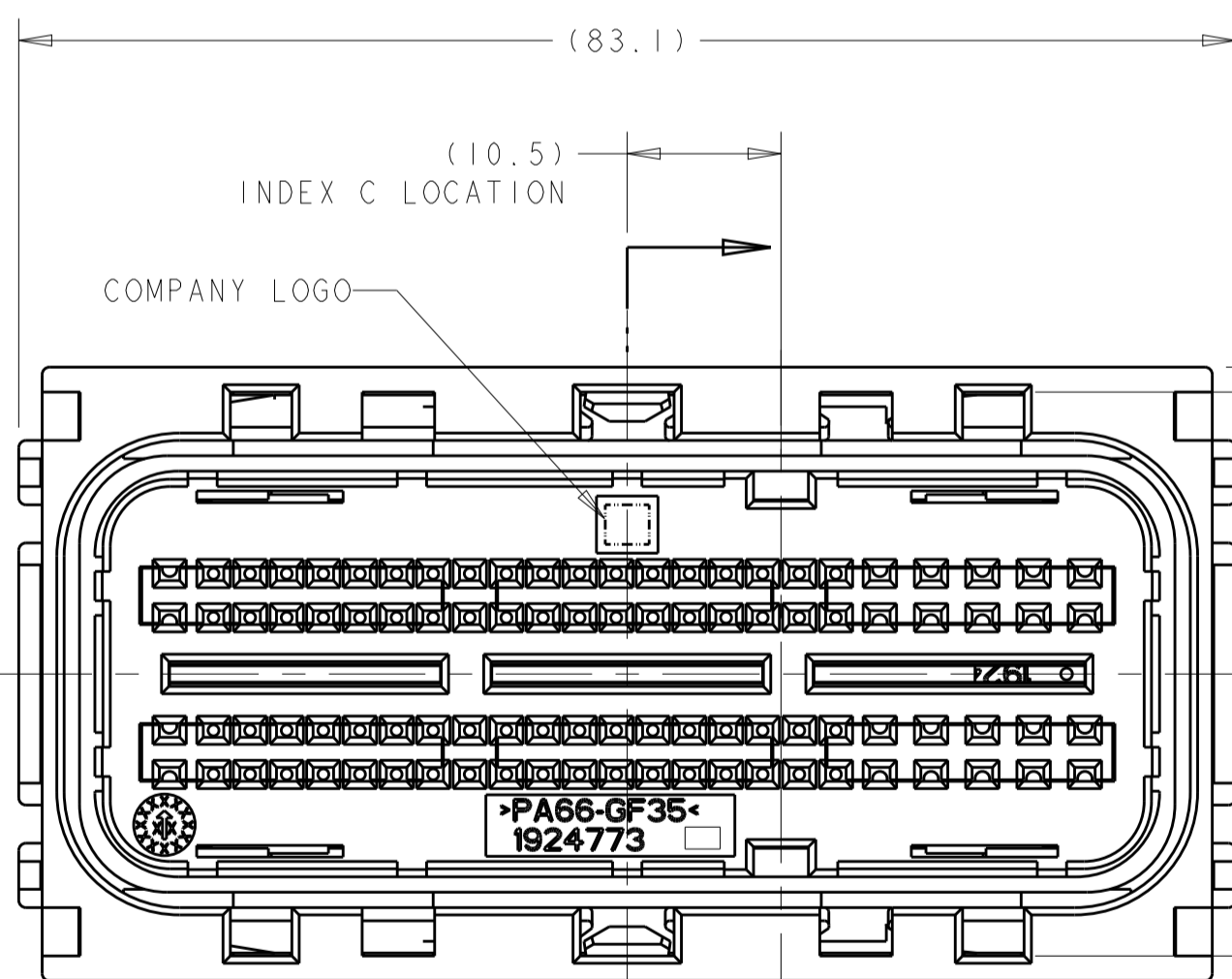
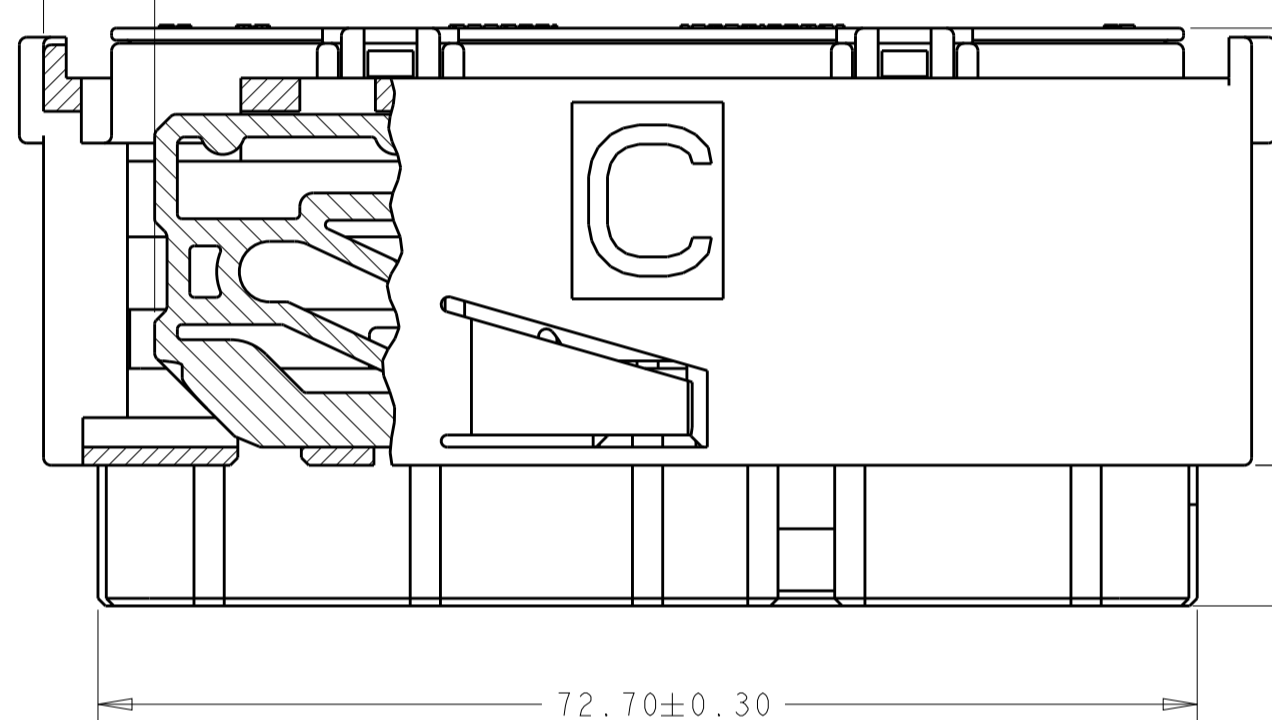
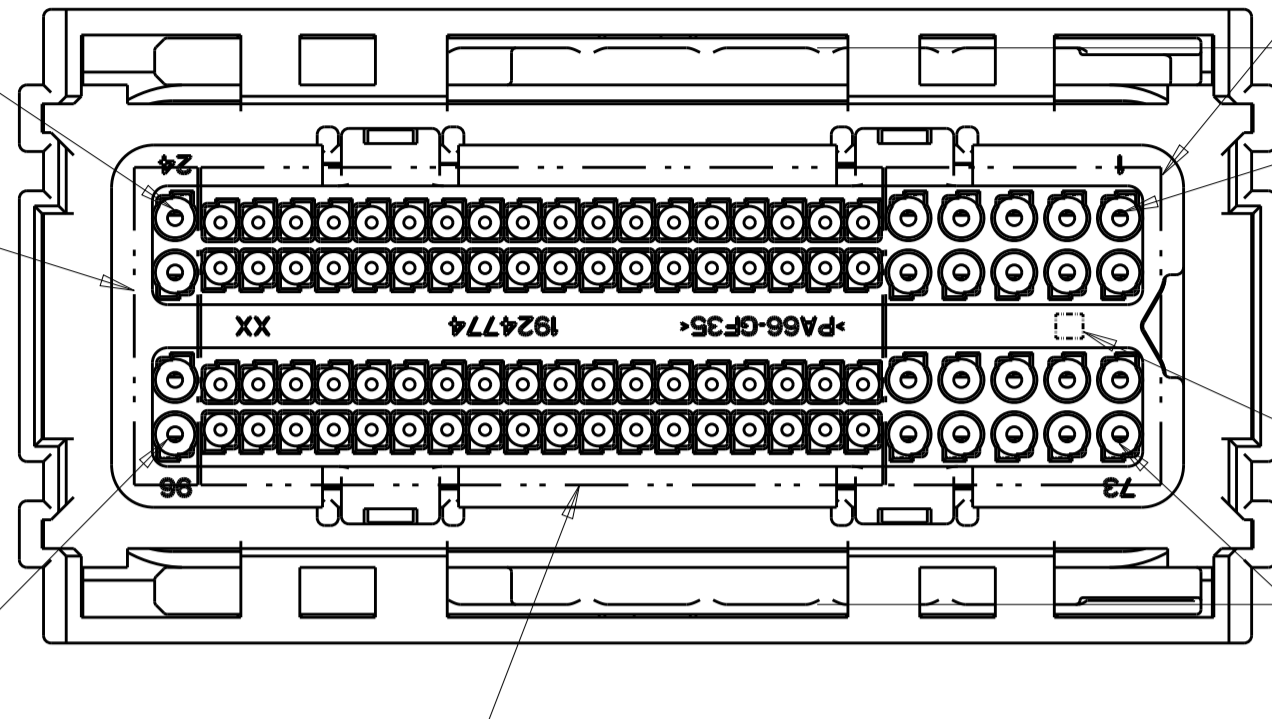

BETA SLIDE (GREEN) C SIDE OF PLUG HOUSING

ASSEMBLY PART NUMBER AND DATE CODE MARKING

ALPHA SLIDE (BLUE) D SIDE OF PLUG HOUSING

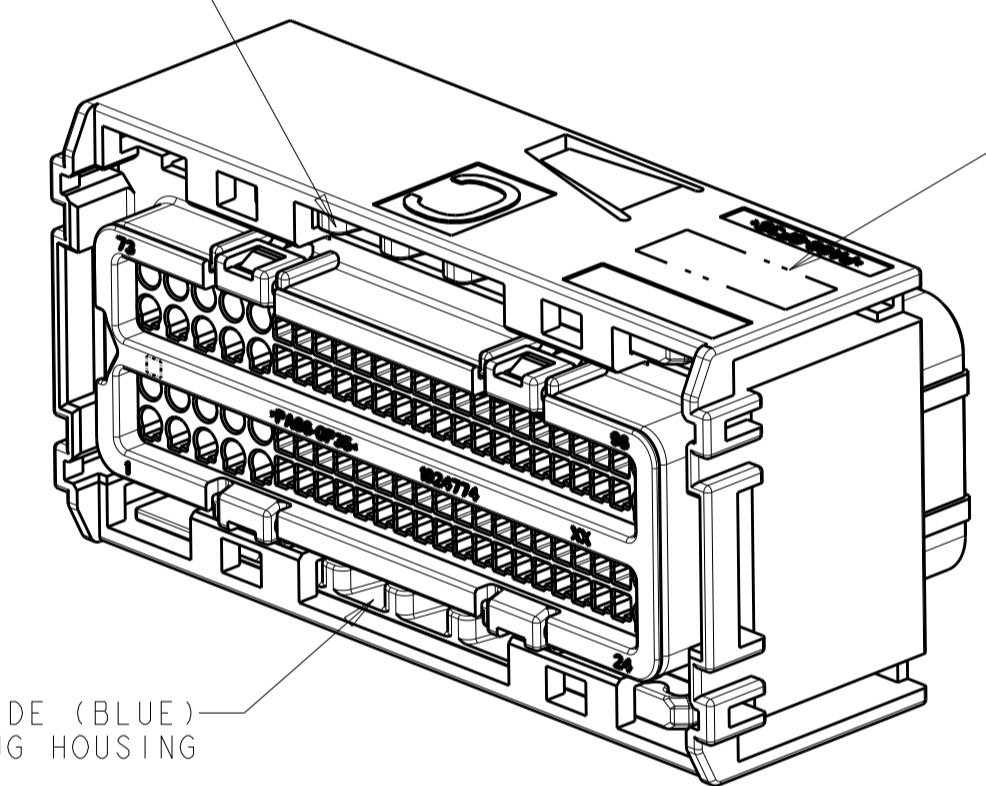

(METHOD FOR IDENTIFYING EXIT ORIENTATION)

BETA SLIDE PERIPHERAL SEAL

TPA

MATTE WIRE SEAL

SEAL COVER

ALPHA SLIDE

PLUG HOUSING

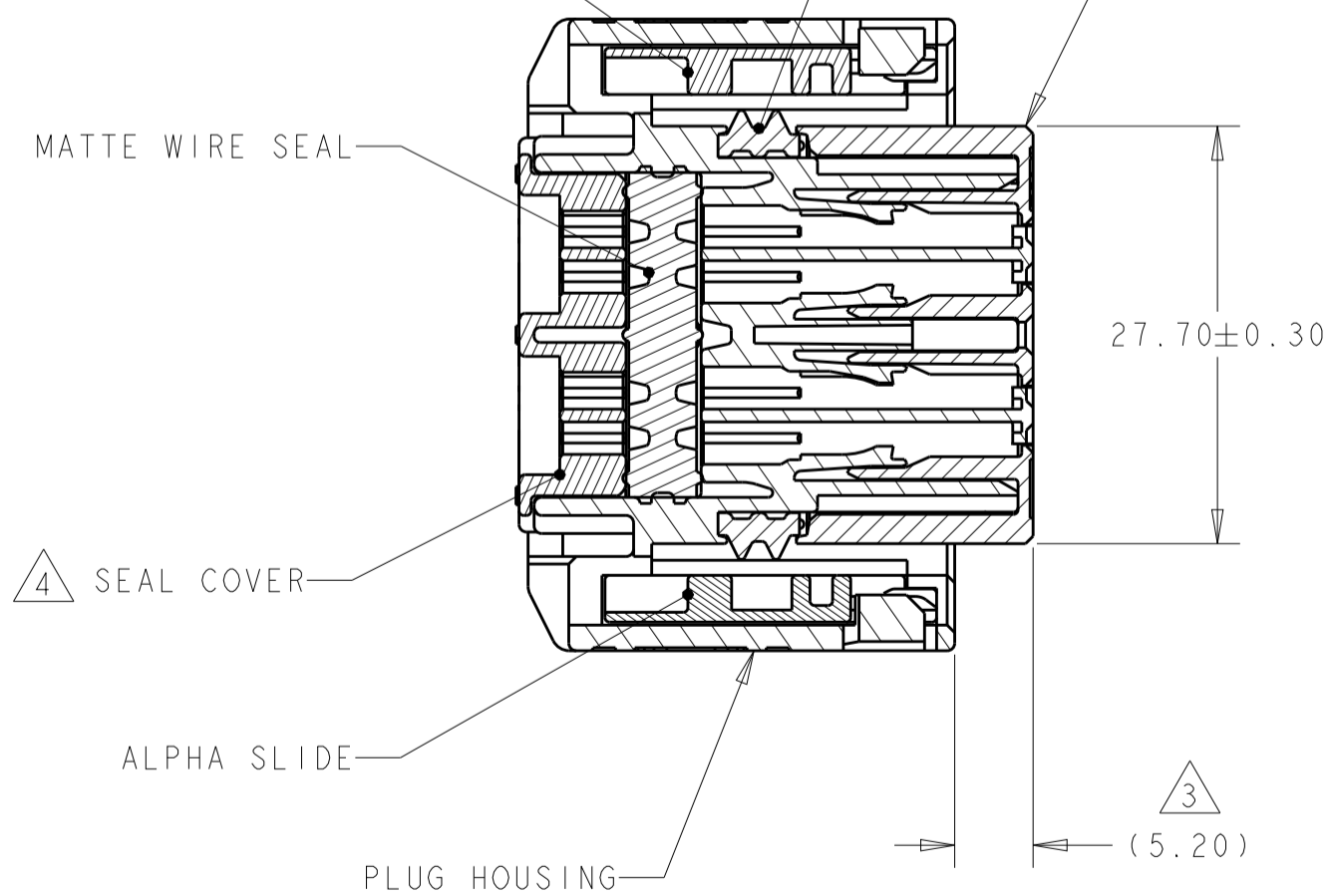

- 1. PLUG HOUSING AND SEAL COVER: NYLON 6/6, BLACK.
 TPA: NYLON 6/6, COLOR - SEE TABLE.
 MATTE WIRE SEAL: SILICONE, LIGHT BLUE.
 PERIPHERAL SEAL: SILICONE, GREEN.
 ALPHA SLIDE: NYLON 6/6, BLUE.
 BETA SLIDE: NYLON 6/6, GREEN.

- 2. TPA SHOWN IN PRE-LATCHED, AS SHIPPED, POSITION.

- 3. TPA SHOWN IN CLOSED POSITION.

- 4. SEE TABLE ON SHEET 2 FOR SEAL COVER PIN OUT CONFIGURATION.

- 5. PLUG ASSEMBLY MATES WITH TYCO ELECTRONICS INTERFACE DRAWING 1924771-INT, POLARIZATION C.

- 6. PLUG ASSEMBLY WILL ACCEPT THE FOLLOWING GET TERMINAL PART NUMBERS: 1393364-1 (GOLD 22AWG; 0.35mm²)
 1393365-1 (GOLD 18-20AWG; 0.75mm²-0.5mm²)
 1924878-1 (TIN/SILVER 22AWG; 0.35mm²)
 1924879-1 (TIN/SILVER 18-20AWG; 0.75mm²-0.5mm²)
 1924782-1 (TIN/SILVER 1.0mm²)
 1924880-1 (TIN/SILVER 16AWG; 1.5mm²)

- 7. WIRE DRESS ASSEMBLY MUST BE INSTALLED ONTO PLUG ASSEMBLY WITH LEVER IN LOCKED POSITION.

- 8. APPLICATION SPEC'S: 408-10229, 408-10230.

- 9. NOTE DELETED.

- 10. FORCE TO SEAT TPA COMPONENT FROM PRE-SET TO LOCKED (FULLY LOADED W/ TERMINALS) TO BE 83N MAX.

- 11. FORCE TO MOVE TPA FROM FULLY LOCKED TO PRE-SET TO BE 115N MAX. FLAT BLADE SCREWDRIVER SUGGESTED FOR REMOVAL OF TPA.

| | | | |
|------------------|-----------|-----------|-------------|
| SEE TABLE, SH 2 | TAN | C | 1924942-7 |
| SEE TABLE, SH 2 | TAN | C | 1924942-6 |
| SEE TABLE, SH 2 | TAN | C | 1924942-5 |
| SEE TABLE, SH 2 | TAN | C | 1924942-4 |
| SEE TABLE, SH 2 | TAN | C | 1924942-3 |
| SEE TABLE, SH 2 | TAN | C | 1924942-2 |
| ALL OPEN | TAN | C | 1924942-1 |
| BLOCKED CIRCUITS | TPA COLOR | INDEX REF | PART NUMBER |

THIS DRAWING IS A CONTROLLED DOCUMENT.

OWN: J. HARDY 29NOV2007
 CHK: A. J. VASBINDER 03DEC2007
 APVD: A. J. VASBINDER 03DEC2007

DIMENSIONS: mm
 TOLERANCES UNLESS OTHERWISE SPECIFIED:
 0 PLC ±
 1 PLC ±
 2 PLC ±0.25
 3 PLC ±
 4 PLC ±
 ANGLES ±
 FINISH

MATERIAL:

WEIGHT:

CUSTOMER DRAWING

NAME: PLUG ASSEMBLY, 96 POSITION, INDEX C - LEFT EXIT, SEALED, GPEC 11

SIZE: A1
 CAGE CODE: 100779
 DRAWING NO: 1924942

RESTRICTED TO: C3

SCALE: 2:1 SHEET 1 OF 2 REV: C3

