

PART NUMBER	REVISION	DESCRIPTION	FEED TYPE
2266562-1	G	FINE CRIMP HEIGHT ADJUST	MECHANICAL
2266562-2	G	FINE CRIMP HEIGHT ADJUST	PNEUMATIC
7-2266562-1	G	MECHANICAL AND CRIMP TOOLING KIT	MECHANICAL
7-2266562-2	G	PNEUMATIC AND CRIMP TOOLING KIT	PNEUMATIC
7-2266562-7	A	CRIMP TOOLING KIT	-

ATLANTIC VERSION TERMINATOR INTERFACE ADAPTER



APPLICATOR DATA		
CRIMP	SIZE	TYPE
WIRE	2.49 mm [.098]	F
INSUL	2.54 mm [.100]	F

APPLICATOR INSTRUCTIONS
408-35042

TERMINAL DATA: MOLEX TERMINAL MOLEX CRIMP SPECIFICATION			
TERMINAL NAME: MX150 RECEPTACLE			
WIRE STRIP LENGTH	INSULATION DIAMETER RANGE		
4.70-5.60 mm [.185-.220 IN]	Ø2.18-2.69 mm [.086-.106 IN]		
TERMINAL APPLICATION SPECIFICATION			
TERMINALS APPLIED			
TE TERMINAL	MOLEX TERMINAL	TE TERMINAL	MOLEX TERMINAL
1949354-1	33012-3001	1949354-5	33001-5001
1949354-2	33001-3003	1949354-6	33001-5021
1949354-3	33012-3021	1949354-7	34750-1001
1949354-4	33001-3021	1949354-8	7C3T14471EA

TERMINAL DATA: MOLEX TERMINAL MOLEX CRIMP SPECIFICATION			
TERMINAL NAME: MX150 RECEPTACLE			
WIRE STRIP LENGTH	INSULATION DIAMETER RANGE		
4.70-5.60 mm [.185-.220 IN]	Ø2.20-2.40 mm [.087-.094 IN]		
TERMINAL APPLICATION SPECIFICATION			
TERMINALS APPLIED			
TE TERMINAL	MOLEX TERMINAL	TE TERMINAL	MOLEX TERMINAL
1949354-1	33012-3001	1949354-5	33001-5001
1949354-2	33001-3003	1949354-6	33001-5021
1949354-3	33012-3021	1949354-7	34750-1001
1949354-4	33001-3021	1949354-8	7C3T14471EA

WIRE SIZE	CRIMP HEIGHT mm [INCH]	CRIMP HEIGHT REFERENCE SETTING
14 AWG OR 2.00mm2	1.60 +/- 0.05 [.063 +/- .002]	6.3
16 AWG OR 1.27mm2	1.35 +/- 0.05 [.053 +/- .002]	8.9

WIRE SIZE	CRIMP HEIGHT mm [INCH]	CRIMP HEIGHT REFERENCE SETTING
1.50mm2	1.40 +/- 0.05 [.055 +/- .002]	8.7

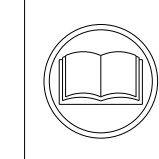

- RECOMMENDED SPARE PARTS
- REFER TO SUPPLIED INSTRUCTION SHEET FOR CLEANING, LUBRICATION AND STORAGE OF APPLICATOR.
- APPLY PART NUMBER 2-23419-6 LOCTITE TO THREADS OF ITEM 242.
- CRIMP HEIGHT REFERENCE SETTING WAS THE SETTING USED WHEN THE APPLICATOR WAS QUALIFIED AT THE FACTORY. ADJUSTMENT MAY BE NECESSARY WHEN RUNNING APPLICATOR IN THE FIELD.
- TERMINAL LUBRICANT IS RECOMMENDED.
- UNLESS SPECIFIED OTHERWISE TORQUE VALUES SHALL BE USED PER DOCUMENT, 101-35000.

***WARNING**
ON INSTALLATION, SET WIRE DISC TO CRIMP HEIGHT REFERENCE SETTING FOR LARGEST WIRE SIZE. CRIMP HEIGHT REFERENCE SETTINGS GREATER THAN THE VALUE SHOWN MAY CAUSE DAMAGE TO THE CRIMP TOOLING. REFER TO THE INSTRUCTION SHEET FOR PROPER SETUP AND ADJUSTMENTS.

ATLANTIC VERSION
Shown on sheets 1 of 4 & 2 of 4
(Pacific version shown on sheets 3 of 4 & 4 of 4)

LOC	DIST	REVISIONS					
		P	LTN	DESCRIPTION	DATE	OWN	APVD
A	66	D		ECR-17-002702	23FEB2017	TB	TE
		E		ECR-18-016279	14OCT2018	TB	TE
		F		ECR-22-137339	28APR2022	FZ	TE
		G		ECR-23-171863	11APR2023	FZ	TE

-	1	-	1	-	2119641-1	FEED CAM, AIR FEED	248	
-	1	1	1	1	2119082-8	CAM, SNAIL, INSULATION ADJUSTMENT	244	
-	1	1	1	1	2079764-1	WASHER, WAVE SPRING, CREST-TO-CREST	243	
3	-	1	1	1	2119083-1	RETAINER, INSULATION DIAL	242	
-	1	1	1	1	7-18023-7	SCR, SKT HD CAP M3 X 4.0	241	
-	-	1	-	1	2119580-1	MECHANICAL FEED ASSEMBLY	239	
-	1	-	1	-	2844940-1	AIR FEED MODULE	238	
-	REF	REF	REF	REF	994970-2	COUNTER, MAGNETIC	164	
-	1	1	1	1	1-22281-8	SPRING, COMPRESSION	121	
5	-	1	1	1	2119955-1	ASSY, LUBRICATOR, SIDE FEED	113	
-	1	1	1	1	2844908-1	SCREW, LOCKING	99	
-	1	1	1	1	2844907-1	POST, LOCKING	98	
-	1	1	1	1	2-690438-2	FRONT STRIP GUIDE	96	
-	2	2	2	2	2168083-1	SCR, SKT HD CAP, RoHS, M3 X 8.0	95	
-	1	1	1	1	2168083-6	SCR, SKT HD CAP, RoHS, M5 X 65	93	
-	1	1	1	1	455888-7	SPACER, CRIMPER	82	
-	1	1	1	1	5-547505-2	SPRING, COMPRESSION	77	
-	1	1	1	1	854769-4	HOLDER, INS	74	
-	1	1	1	1	1803607-3	DOCUMENTATION PACKAGE	71	
-	1	1	1	1	2119740-1	TAG, IDENTIFICATION	67	
-	2	2	2	2	2168078-1	SCREW, DRIVE, RH, RoHS, 2 x .188	66	
-	2	2	2	2	2-18032-5	SCR, SET, FLT PNT, M5 X 20.0	61	
-	1	1	1	1	2168083-2	SCR, SKT HD CAP, RoHS, M4 X 8.0	60	
-	1	1	1	1	5-18022-5	SCR, HEX HD CAP, M4 X 6.0	59	
-	1	1	1	1	21028-2	PIN, SLOTTED SPRING .062 X .250	58	
-	1	1	1	1	1338685-1	PAWL, FEED	56	
-	4	4	4	4	2168083-3	SCR, SKT HD CAP, RoHS, M4 X 12.0	54	
-	2	2	2	2	1-2168083-0	SCR, SKT HD CAP, RoHS, M4 X 10	53	
-	1	1	1	1	5018030-1	NUT, HEX, REG, RoHS, M3	52	
-	1	1	1	1	811242-5	BUMPER, HOLD DOWN	51	
-	1	1	1	1	690753-2	SPACER, TONKER	50	
-	1	2	1	2	18023-9	SCR, SKT HD CAP M4 X 6.0	49	
-	-	1	-	1	2119652-1	FEED CAM, PRE FEED	48	
-	-	1	-	1	2119653-1	FEED CAM, POST FEED	47	
-	1	1	1	1	1803583-9	APPLICATOR BASIC ASSEMBLY, SF	46	
-	1	1	1	1	1803515-1	RAM ASSEMBLY, SF ATLANTIC	44	
-	1	1	1	1	1803602-1	SCR, BHSC, RoHS (M8 X 25)	41	
-	1	1	1	1	1752356-3	SUPPORT, TERMINAL	34	
-	2	2	2	2	2079383-5	SCR, BHSC, RoHS (M4 X 20)	33	
-	2	2	2	2	3-2844962-0	SPACER, CYLINDRICAL, STRIP GUIDE	30	
-	1	1	1	1	2844938-5	PLATE, STRIP GUIDE	29	
-	1	1	1	1	455888-3	SPACER, CRIMPER	28	
-	2	2	2	2	22283-1	SPRING, COMPRESSION	27	
-	1	1	1	1	356835-1	LEVER, DRAG RELEASE	26	
-	1	1	1	1	240792-1	DRAG, TERMINAL	25	
-	1	1	1	1	1320928-2	STRIP GUIDE	24	
-	1	1	1	1	980371-4	SCR, SKT HD SHLDR 5.0 DIA X 6.0	23	
-	1	1	1	1	2168083-2	SCR, SKT HD CAP, RoHS, M4 X 8.0	21	
-	2	2	2	2	1-18028-2	WASHER, FLAT, REG M4	20	
-	1	1	1	1	2119533-1	STRIPPER, SIDE FEED	19	
1	-	1	1	1	2119806-1	INSERT, SHEAR	13	
-	1	1	1	1	3-22280-3	SPRING, COMPRESSION	12	
-	1	1	1	1	1-356885-4	STOP, SHEAR	11	
1	-	1	1	1	2119805-1	SHEAR HOLDER, FRONT	10	
1	-	1	1	1	318707-1	FLOATING SHEAR, FRONT	9	
1	1	2	2	1	1	2-1803056-8	ANVIL, COMBINATION	8
-	-	-	-	-	-	-	7	
-	-	-	-	-	-	-	6	
-	1	1	1	1	2119780-9	DEPRESSOR, SHEAR	5	
-	1	1	1	1	238011-2	BLOCK, CRIMPER SPACER	4	
1	1	2	2	1	1	1803223-1	CRIMPER, INSULATION F PREMIUM	3
-	1	1	1	1	455888-4	SPACER, CRIMPER	2	
1	1	2	2	1	1	6-1490019-0	CRIMPER, WIRE PREMIUM	1

DIMENSIONS:		TOLERANCES UNLESS OTHERWISE SPECIFIED:		DRAWING NO		RESTRICTED TO	
mm	0 PLC ±	1 PLC ±	2 PLC ±	3 PLC ±	4 PLC ±	ANGLES ±	FINISH ±
MATERIAL				WEIGHT	SCALE	SHEET	REV
Customer Accessible Production Drawing				SCALE	1:2	SHEET 1 of 4	REV G

LOC	DIST	REVISIONS					
A	66	P	LYN	DESCRIPTION	DATE	OWN	APVD
		-		SEE SHEET 1			

FEED TYPE MECHANICAL

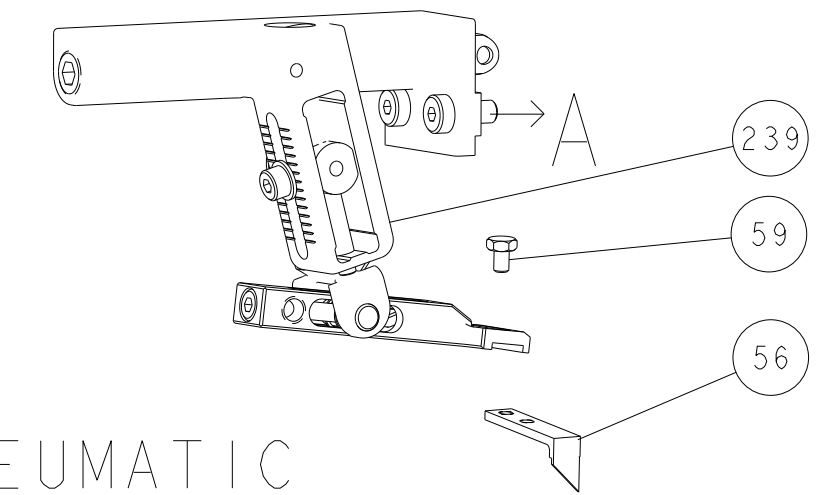

PNEUMATIC

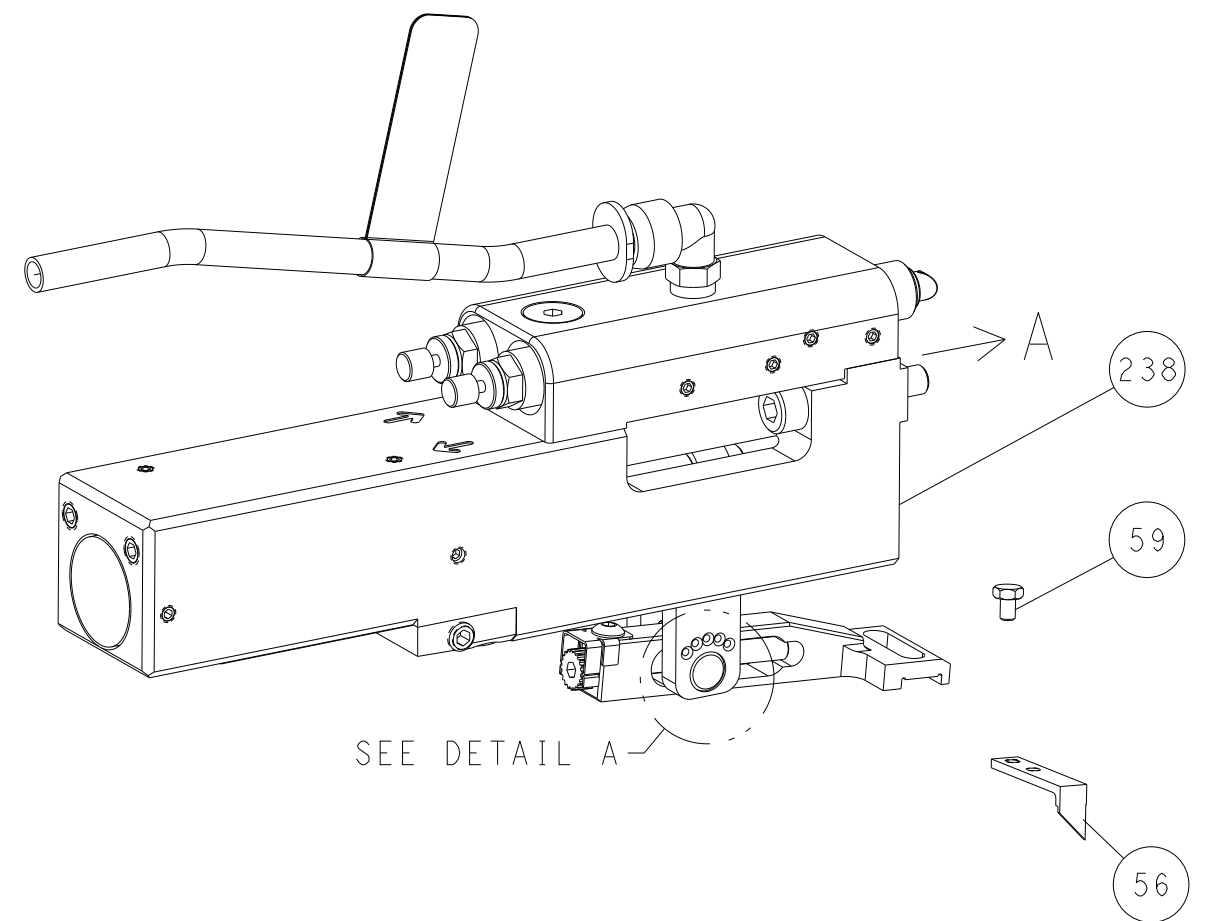

FEED SPRING SETTING POSITION (SHOWN FROM REAR SIDE)

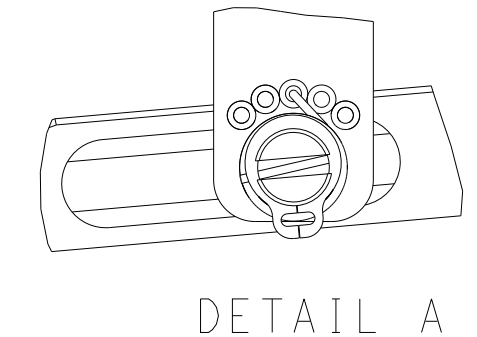

DETAIL A

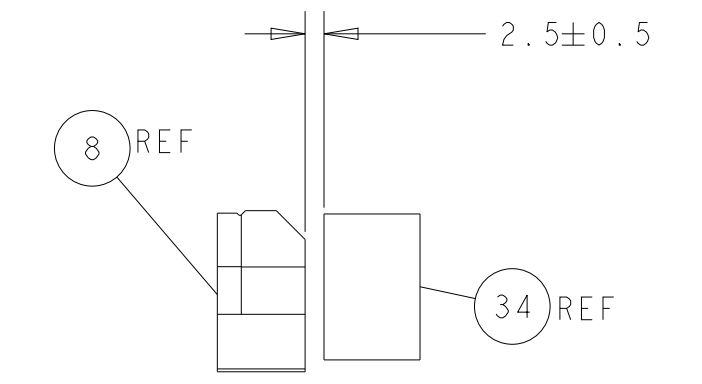
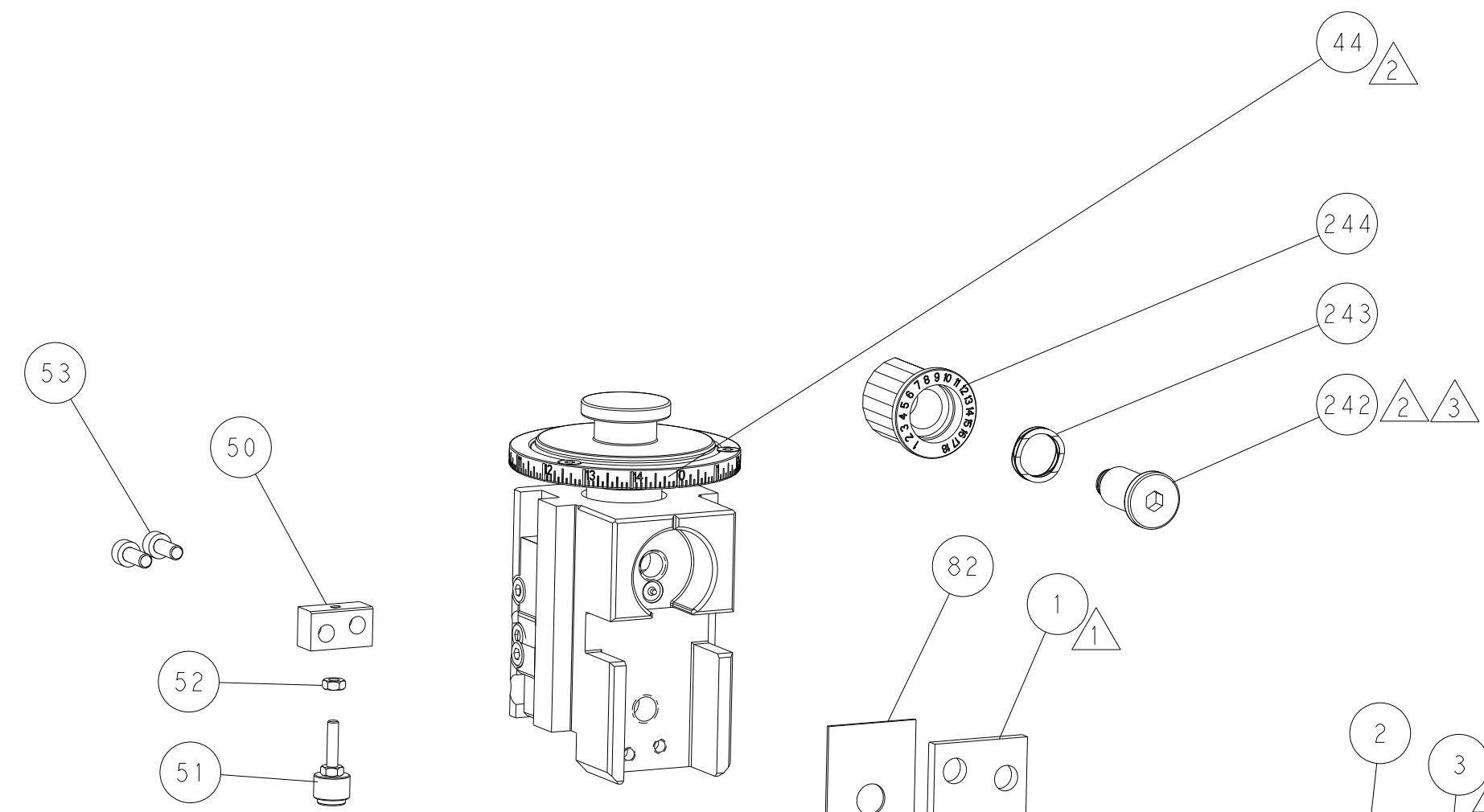

TERMINAL SUPPORT LOCATION

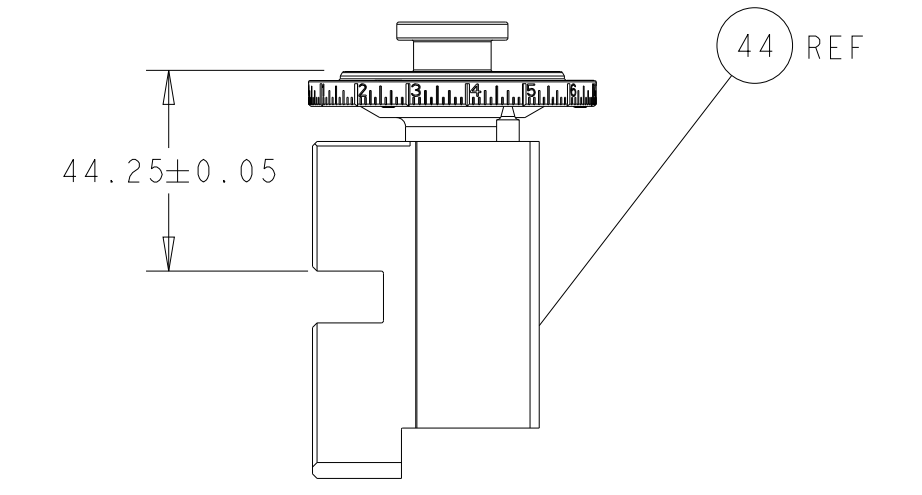
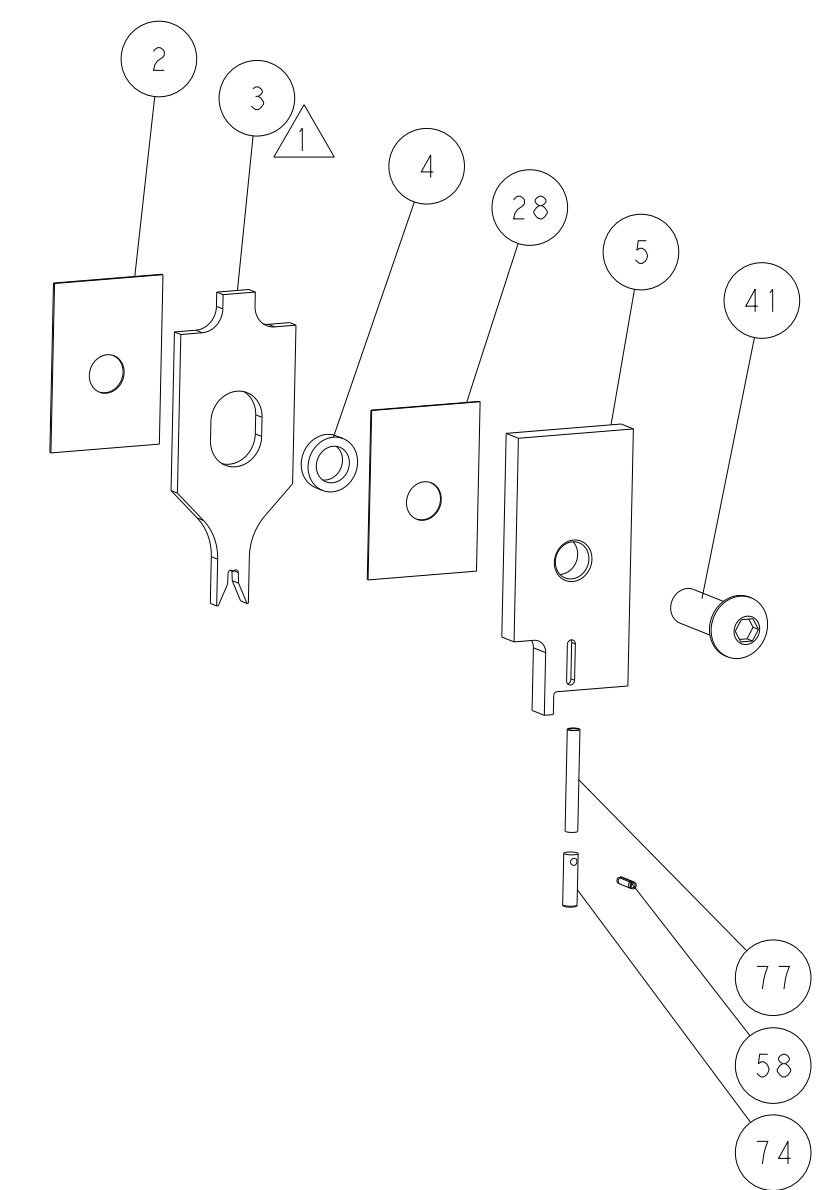

RAM SET-UP

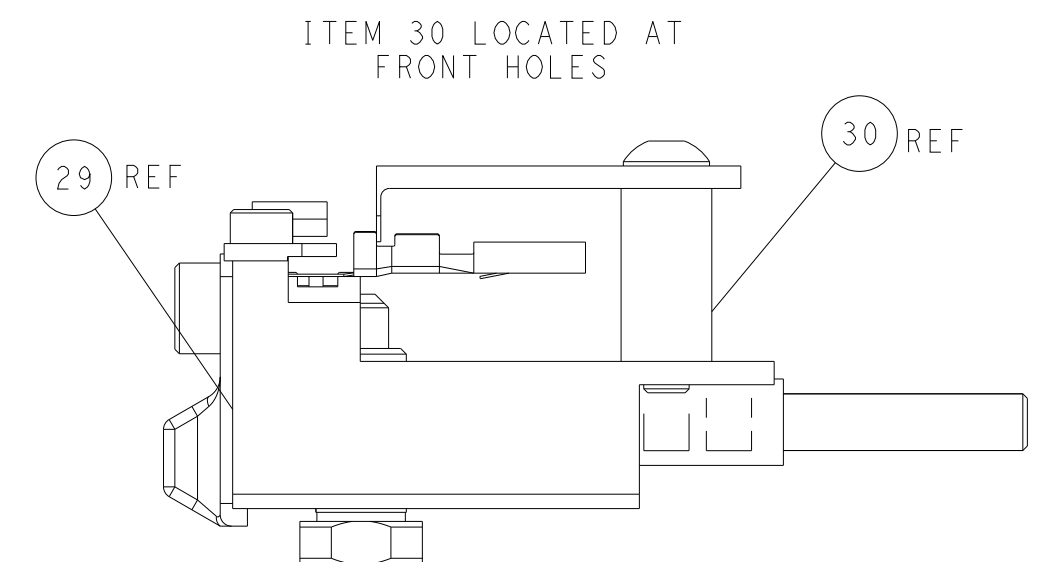
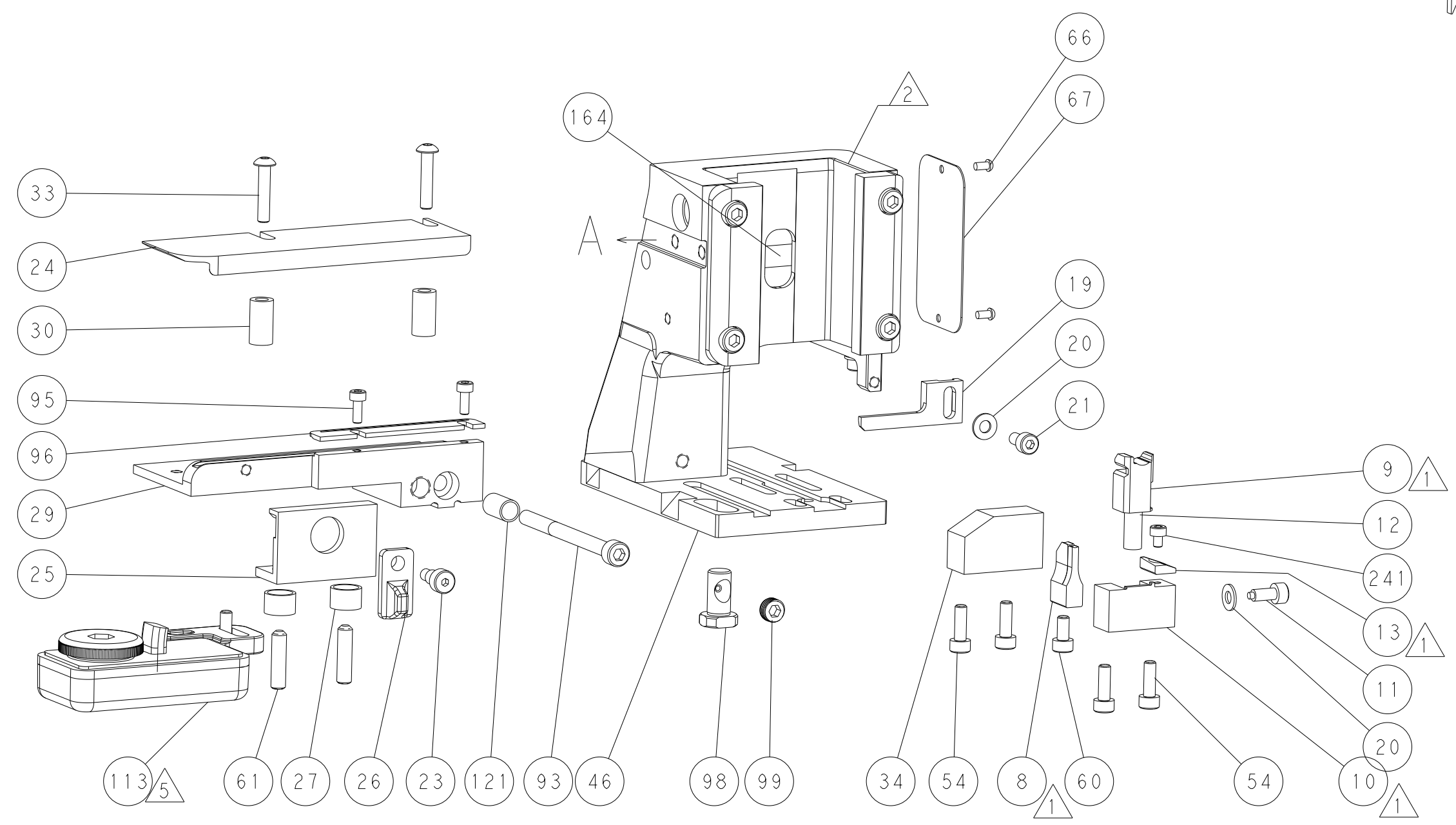

FEED TRACK POSITION GUIDE BY INSULATION BARREL

CAM POSITIONS

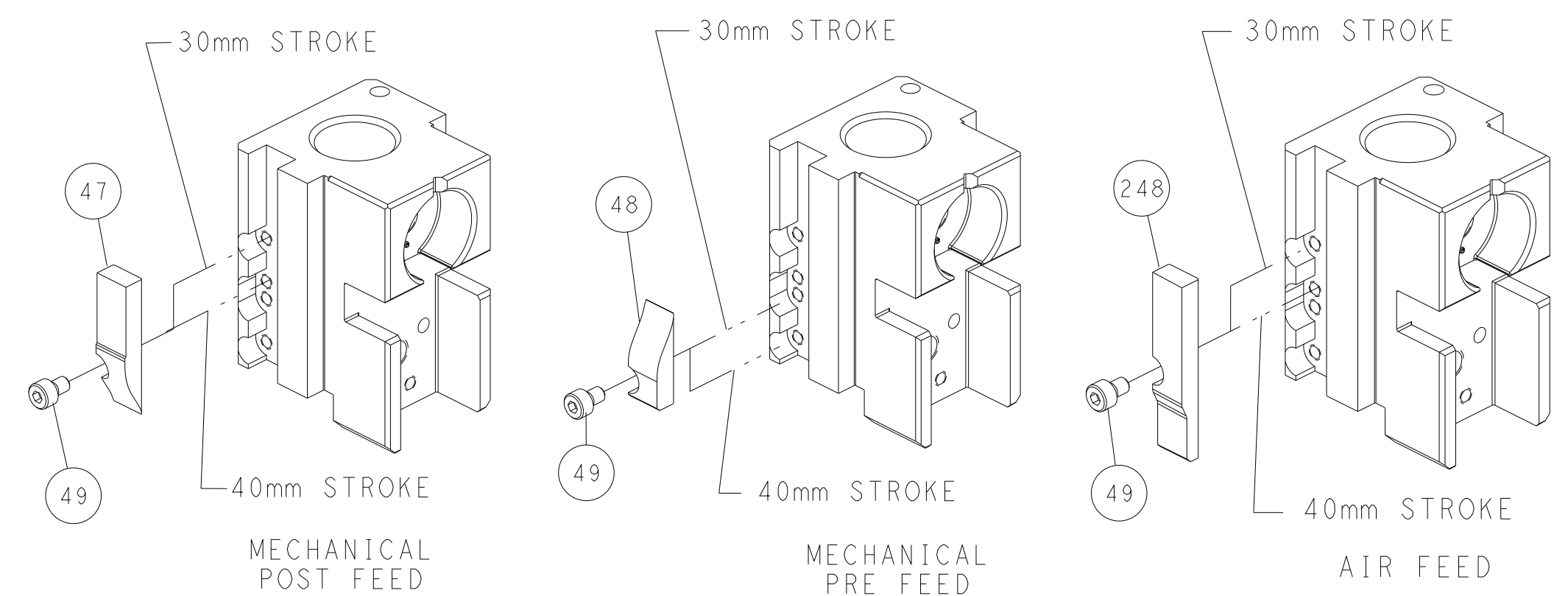

ATLANTIC VERSION
 Shown on sheets 1 of 4 & 2 of 4
 (Pacific version shown on sheets 3 of 4 & 4 of 4)

DIMENSIONS:		TOLERANCES UNLESS OTHERWISE SPECIFIED:		DWN Y. YIN 30OCT2014		TE Connectivity	
mm	0 PLC ±	1 PLC ±	2 PLC ±	3 PLC ±	4 PLC ±	Harrisburg, PA 17105-3608	
MATERIAL:		FINISH:		CHK G. BAILEY 30OCT2014		NAME	
				U. GUO 30OCT2014		Ocean Side Feed Applicator	
				APVD		SIZE CAGE CODE DRAWING NO	
				PRODUCT SPEC		RESTRICTED TO	
				APPLICATION SPEC		A 00779 C=2266562	
				WEIGHT		SCALE 1:2 SHEET 2 OF 4 REV G	
				Customer Accessible Production Drawing		SHEETS 3 & 4 ARE NOT REQUIRED FOR ATLANTIC VERSION	

PART NUMBER	REVISION	DESCRIPTION	FEED TYPE
2-2266562-1	G	FINE CRIMP HEIGHT ADJUST	MECHANICAL
2-2266562-2	G	FINE CRIMP HEIGHT ADJUST	PNEUMATIC
7-2266562-7	A	CRIMP TOOLING KIT	-

PACIFIC VERSION TERMINATOR
INTERFACE ADAPTER

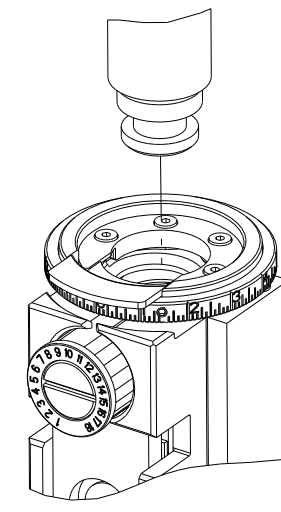

APPLICATOR DATA		
CRIMP	SIZE	TYPE
WIRE	2.49 mm [.098]	F
INSUL	2.54 mm [.100]	F
APPLICATOR INSTRUCTIONS 408-35042		

TERMINAL DATA: MOLEX TERMINAL MOLEX CRIMP SPECIFICATION			
TERMINAL NAME: MX150 RECEPTACLE			
WIRE STRIP LENGTH		INSULATION DIAMETER RANGE	
4.70-5.60 mm [1.85-.220 IN]		Ø2.18-2.69 mm [.086-.106 IN]	
TERMINAL APPLICATION SPECIFICATION ATS-639000700 Rev F			
TERMINALS APPLIED			
TE TERMINAL	MOLEX TERMINAL	TE TERMINAL	MOLEX TERMINAL
1949354-1	33012-3001	1949354-5	33001-5001
1949354-2	33001-3003	1949354-6	33001-5021
1949354-3	33012-3021	1949354-7	34750-1001
1949354-4	33001-3021	1949354-8	7C3T14471EA

TERMINAL DATA: MOLEX TERMINAL MOLEX CRIMP SPECIFICATION			
TERMINAL NAME: MX150 RECEPTACLE			
WIRE STRIP LENGTH		INSULATION DIAMETER RANGE	
4.70-5.60 mm [1.85-.220 IN]		Ø2.20-2.40 mm [.087-.094 IN]	
TERMINAL APPLICATION SPECIFICATION ATS-639000700 Rev F			
TERMINALS APPLIED			
TE TERMINAL	MOLEX TERMINAL	TE TERMINAL	MOLEX TERMINAL
1949354-1	33012-3001	1949354-5	33001-5001
1949354-2	33001-3003	1949354-6	33001-5021
1949354-3	33012-3021	1949354-7	34750-1001
1949354-4	33001-3021	1949354-8	7C3T14471EA

WIRE SIZE	CRIMP HEIGHT mm [INCH]	CRIMP HEIGHT REFERENCE SETTING
14 AWG OR 2.00mm2	1.60+/-0.05 [1.063+/-0.02]	6.3
16 AWG OR 1.27mm2	1.35+/-0.05 [1.053+/-0.02]	8.9

WIRE SIZE	CRIMP HEIGHT mm [INCH]	CRIMP HEIGHT REFERENCE SETTING
1.50mm2	1.40+/-0.05 [1.055+/-0.02]	8.7

***WARNING**
ON INSTALLATION, SET WIRE DISC TO CRIMP HEIGHT REFERENCE SETTING FOR LARGEST WIRE SIZE. CRIMP HEIGHT REFERENCE SETTINGS GREATER THAN THE VALUE SHOWN MAY CAUSE DAMAGE TO THE CRIMP TOOLING. REFER TO THE INSTRUCTION SHEET FOR PROPER SETUP AND ADJUSTMENTS.

- RECOMMENDED SPARE PARTS
 - REFER TO SUPPLIED INSTRUCTION SHEET FOR CLEANING, LUBRICATION AND STORAGE OF APPLICATOR.
 - APPLY PART NUMBER 2-23419-6 LOCTITE TO THREADS OF ITEM 242.
 - CRIMP HEIGHT REFERENCE SETTING WAS THE SETTING USED WHEN THE APPLICATOR WAS QUALIFIED AT THE FACTORY. ADJUSTMENT MAY BE NECESSARY WHEN RUNNING APPLICATOR IN THE FIELD.
 - TERMINAL LUBRICANT IS RECOMMENDED.
6. UNLESS SPECIFIED OTHERWISE TORQUE VALUES SHALL BE USED PER DOCUMENT, 101-35000.

LOC	DIST	REVISIONS					
A	66	P	LTN	DESCRIPTION	DATE	OWN	APVD
		-		SEE SHEET 1			

-	1	1	2119082-8	CAM, SNAIL, INSULATION ADJUSTMENT	244	
-	1	1	2079764-1	WASHER, WAVE SPRING, CREST-TO-CREST	243	
	-	1	2119083-1	RETAINER, INSULATION DIAL	242	
-	1	1	7-18023-7	SCR, SKT HD CAP M3 X 4.0	241	
-	-	1	2119580-1	MECHANICAL FEED ASSEMBLY	239	
-	1	-	2844940-1	AIR FEED MODULE	238	
-	REF	REF	994970-2	COUNTER, MAGNETIC	164	
-	1	-	2119641-2	FEED CAM, AIR FEED	151	
-	1	1	2168083-8	SCR, SKT HD CAP, RoHS, M4 X 16	144	
-	4	4	2168083-9	SCR, SKT HD CAP, RoHS, M4 X 20	143	
-	-	1	2119653-2	FEED CAM, POST FEED	142	
-	1	1	1-1803583-0	APPLICATOR BASIC ASSEMBLY, SF	141	
-	1	1	1803516-1	RAM ASSEMBLY, SF PACIFIC	140	
-	1	1	1-22281-8	SPRING, COMPRESSION	121	
	-	1	2119955-1	ASSY, LUBRICATOR, SIDE FEED	113	
-	1	1	2844908-1	SCREW, LOCKING	99	
-	1	1	2844907-1	POST, LOCKING	98	
-	1	1	2-690438-2	FRONT STRIP GUIDE	96	
-	2	2	2168083-1	SCR, SKT HD CAP, RoHS, M3 X 8.0	95	
-	1	1	2168083-6	SCR, SKT HD CAP, RoHS, M5 X 65	93	
-	1	1	455888-7	SPACER, CRIMPER	82	
-	1	1	5-547505-2	SPRING, COMPRESSION	77	
-	1	1	854769-4	HOLDER, INS	74	
-	1	1	1803607-3	DOCUMENTATION PACKAGE	71	
-	1	1	2119740-1	TAG, IDENTIFICATION	67	
-	2	2	2168078-1	SCREW, DRIVE, RH, RoHS, 2 x .188	66	
-	2	2	2-18032-5	SCR, SET, FLT PNT, M5 X 20.0	61	
-	1	1	5-18022-5	SCR, HEX HD CAP, M4 X 6.0	59	
-	1	1	21028-2	PIN, SLOTTED SPRING .062 X .250	58	
-	1	1	1338685-1	PAWL, FEED	56	
-	2	2	1-2168083-0	SCR, SKT HD CAP, RoHS, M4 X 10	53	
-	1	1	5018030-1	NUT, HEX, REG, RoHS, M3	52	
-	1	1	811242-5	BUMPER, HOLD DOWN	51	
-	1	1	690753-2	SPACER, TONKER	50	
-	1	2	18023-9	SCR, SKT HD CAP M4 X 6.0	49	
-	-	1	2119652-1	FEED CAM, PRE FEED	48	
-	1	1	1803602-1	SCR, BHSC, RoHS (M8 X 25)	41	
-	1	1	1752356-3	SUPPORT, TERMINAL	34	
-	2	2	2079383-5	SCR, BHSC, RoHS (M4 X 20)	33	
-	2	2	3-2844962-0	SPACER, CYLINDRICAL, STRIP GUIDE	30	
-	1	1	2844938-5	PLATE, STRIP GUIDE	29	
-	1	1	455888-3	SPACER, CRIMPER	28	
-	2	2	22283-1	SPRING, COMPRESSION	27	
-	1	1	356835-1	LEVER, DRAG RELEASE	26	
-	1	1	240792-1	DRAG, TERMINAL	25	
-	1	1	1320928-2	STRIP GUIDE	24	
-	1	1	980371-4	SCR, SKT HD SHLDR 5.0 DIA X 6.0	23	
-	1	1	2168083-2	SCR, SKT HD CAP, RoHS, M4 X 8.0	21	
-	2	2	1-18028-2	WASHER, FLAT, REG M4	20	
-	1	1	2119533-1	STRIPPER, SIDE FEED	19	
	-	1	2119806-1	INSERT, SHEAR	13	
-	1	1	3-22280-3	SPRING, COMPRESSION	12	
-	1	1	1-356885-4	STOP, SHEAR	11	
	-	1	2119805-1	SHEAR HOLDER, FRONT	10	
	-	1	318707-1	FLOATING SHEAR, FRONT	9	
	1	1	1	2-1803056-8	ANVIL, COMBINATION	8
-	-	-	-	-	7	
-	-	-	-	-	6	
-	1	1	2119780-9	DEPRESSOR, SHEAR	5	
-	1	1	238011-2	BLOCK, CRIMPER SPACER	4	
	1	1	1	1803223-1	CRIMPER, INSULATION F PREMIUM	3
-	1	1	1	455888-4	SPACER, CRIMPER	2
	1	1	1	6-1490019-0	CRIMPER, WIRE PREMIUM	1

PACIFIC VERSION
Shown on sheets 3 of 4 & 4 of 4
(Atlantic version shown on sheets 1 of 4 & 2 of 4)

DIMENSIONS:		TOLERANCES UNLESS OTHERWISE SPECIFIED:		DWG Y. YIN 30OCT2014		CHK G. BAILEY 30OCT2014		APVD J. GUO 30OCT2014		NAME Ocean Side Feed Applicator	
mm	0 PLC ± 1 PLC ± 2 PLC ± 3 PLC ± 4 PLC ± ANGLES ±	mm	±	SIZE	A1	CAGE CODE	00779	DRAWING NO	2266562	RESTRICTED TO	-
MATERIAL		FINISH		WEIGHT		SCALE		SHEET		REV	
						1:2		3 OF 4		G	

LOC	DIST	REVISIONS			
A	66	REV	DATE	BY	APVD
-	SEE SHEET 1	-	-	-	-

FEED TYPE MECHANICAL

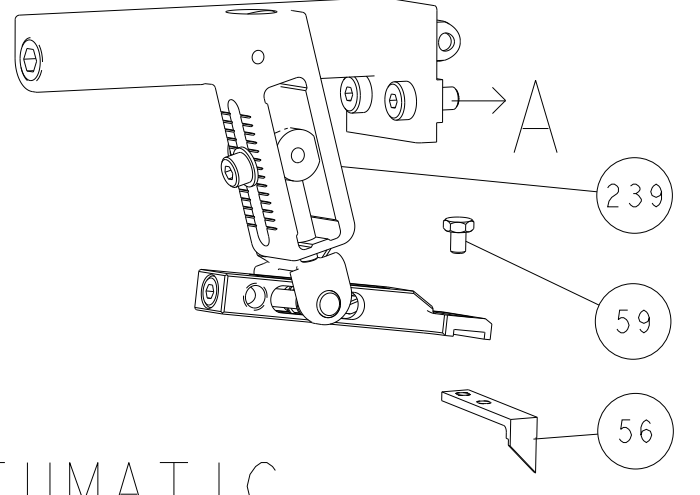

PNEUMATIC

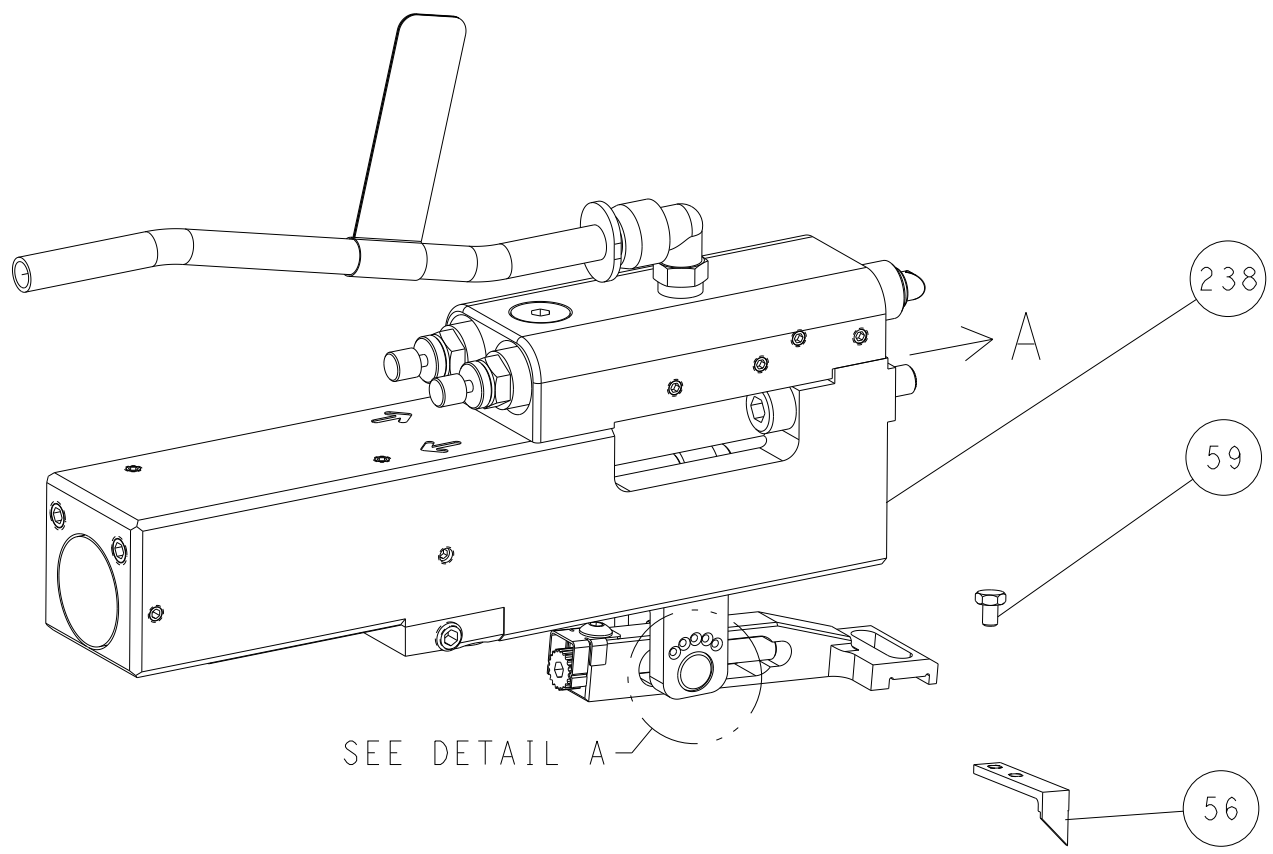

FEED SPRING SETTING POSITION (SHOWN FROM REAR SIDE)

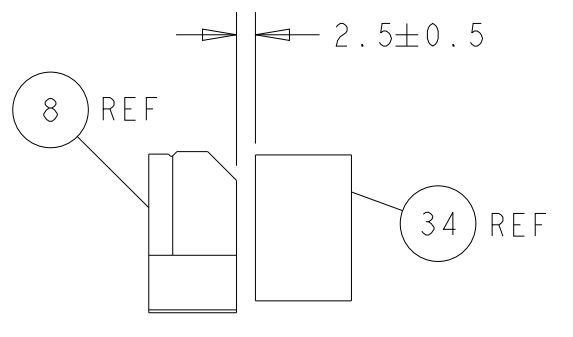
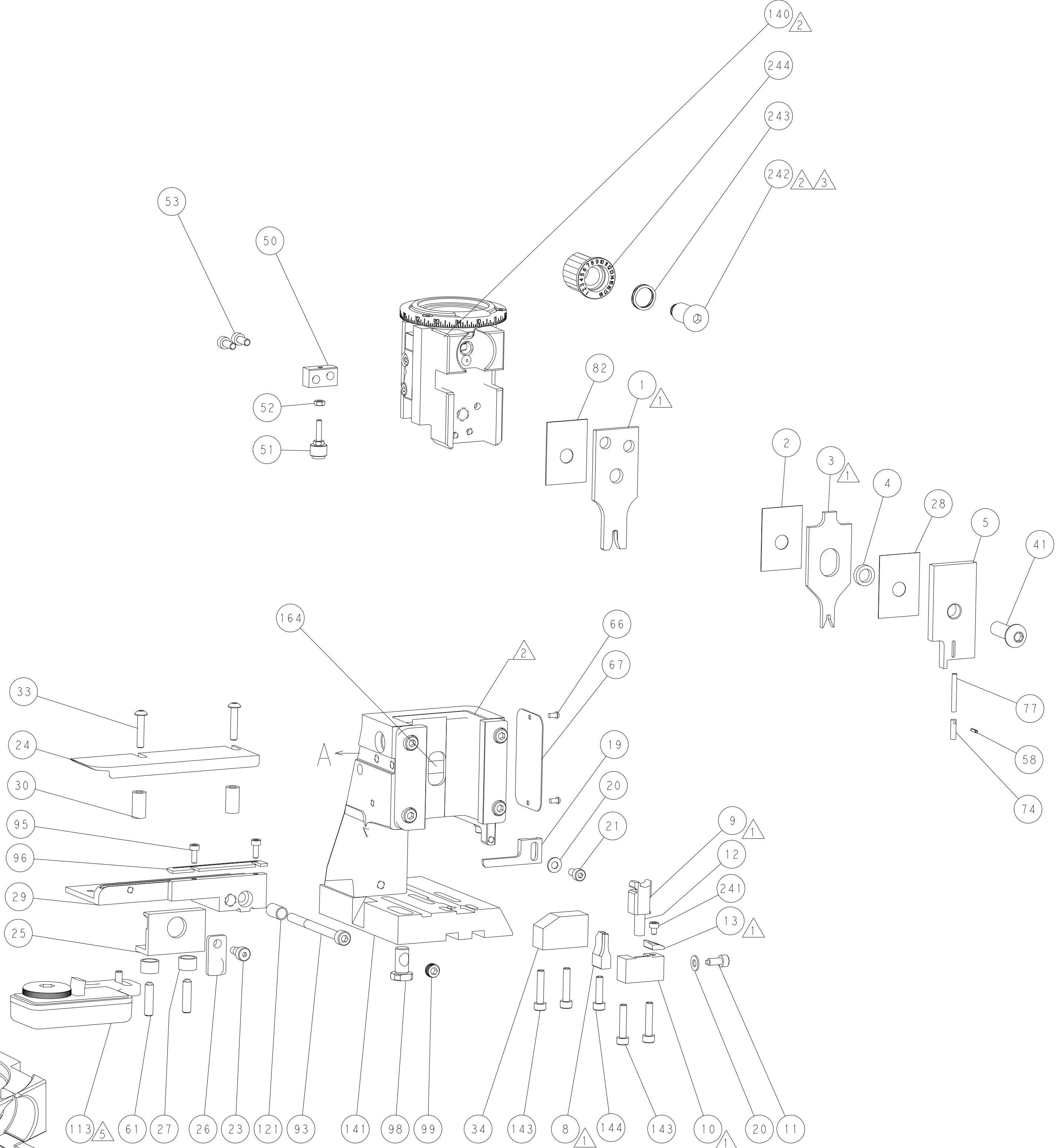
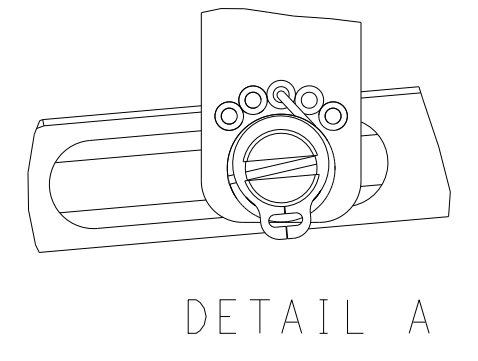

TERMINAL SUPPORT LOCATION

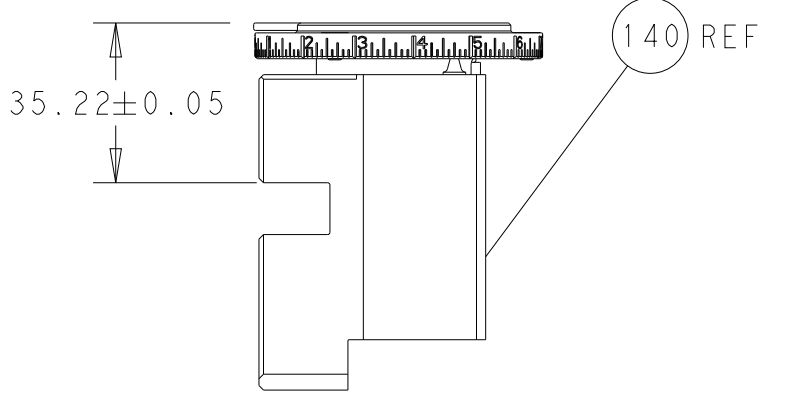

RAM SET-UP

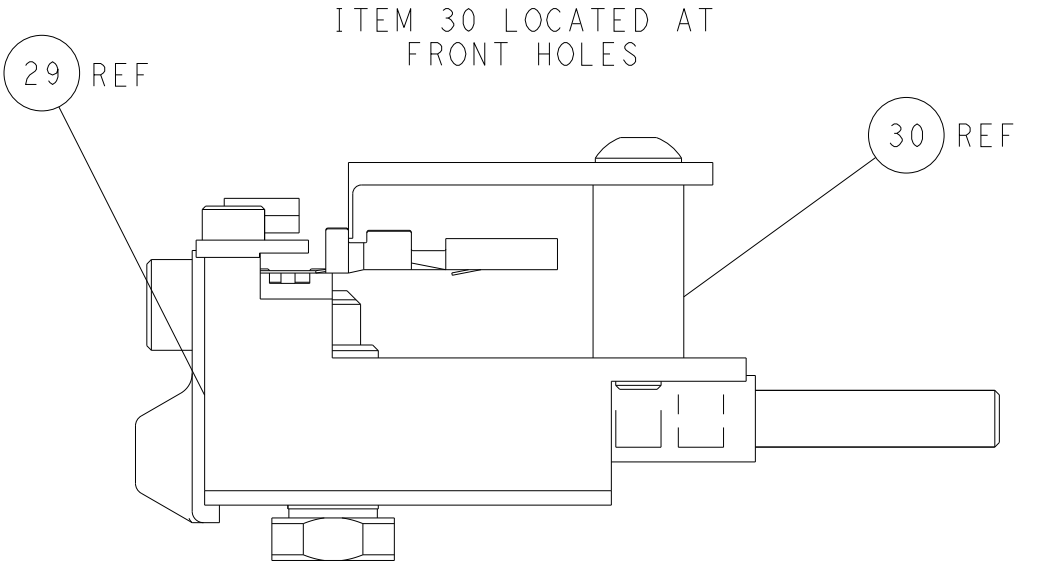

FEED TRACK POSITION
GUIDE BY GUIDE_BY_STR

CAM POSITIONS

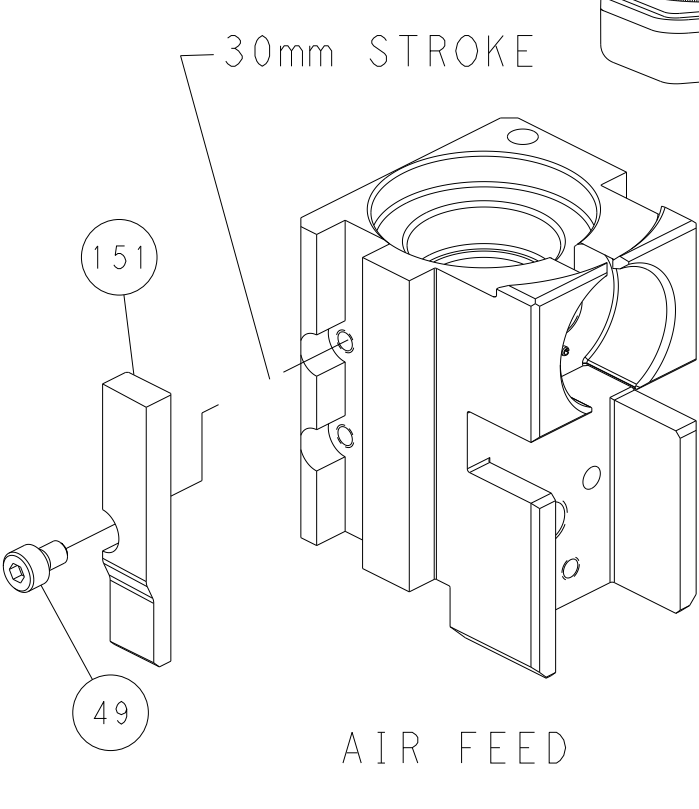
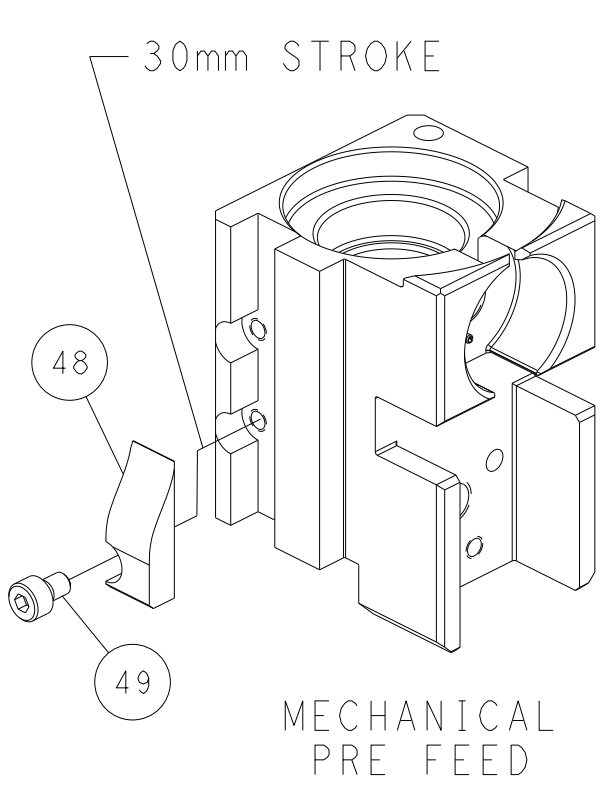
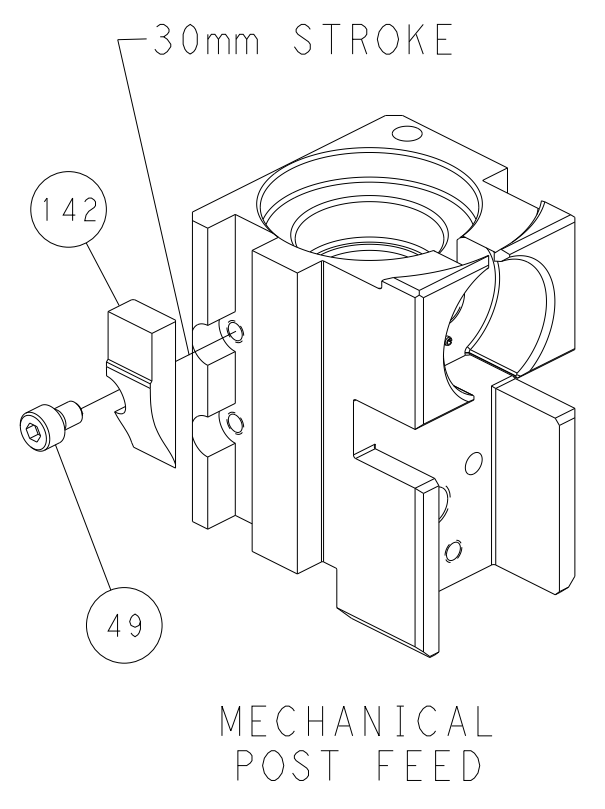

PACIFIC VERSION
 Shown on sheets 3 of 4 & 4 of 4
 (Atlantic version shown on sheets 1 of 4 & 2 of 4)

DIMENSIONS:		TOLERANCES UNLESS OTHERWISE SPECIFIED:		DWG Y. YIN 30OCT2014		TE Connectivity	
mm	0 PLC ±	1 PLC ±	2 PLC ±	3 PLC ±	4 PLC ±	ANGLES ±	FINISH ±
MATERIAL		WEIGHT		SCALE	1:2	SHEET	4 OF 4
Customer Accessible Production Drawing				A1 00779 ©=2266562		RESTRICTED TO	