



# THCV226 8LANE Evaluation board

V-by-One HS receiver evaluation board

Parts Number: THEVA226-8LANE

## 1. Description

THEVA226-8LANE is designed to support video data transmission between the host and display. This board can receive 32bit video data and 3bit control data via four differential pairs of V-by-One HS lanes. This chip supports the video data transmission up to 1080p/10b/240Hz, 4K2K/10b/60Hz. The maximum serial data rate is 3.4Gbps/lane. The supply voltage range is "5V to 12V".

## 2. Connection Diagram

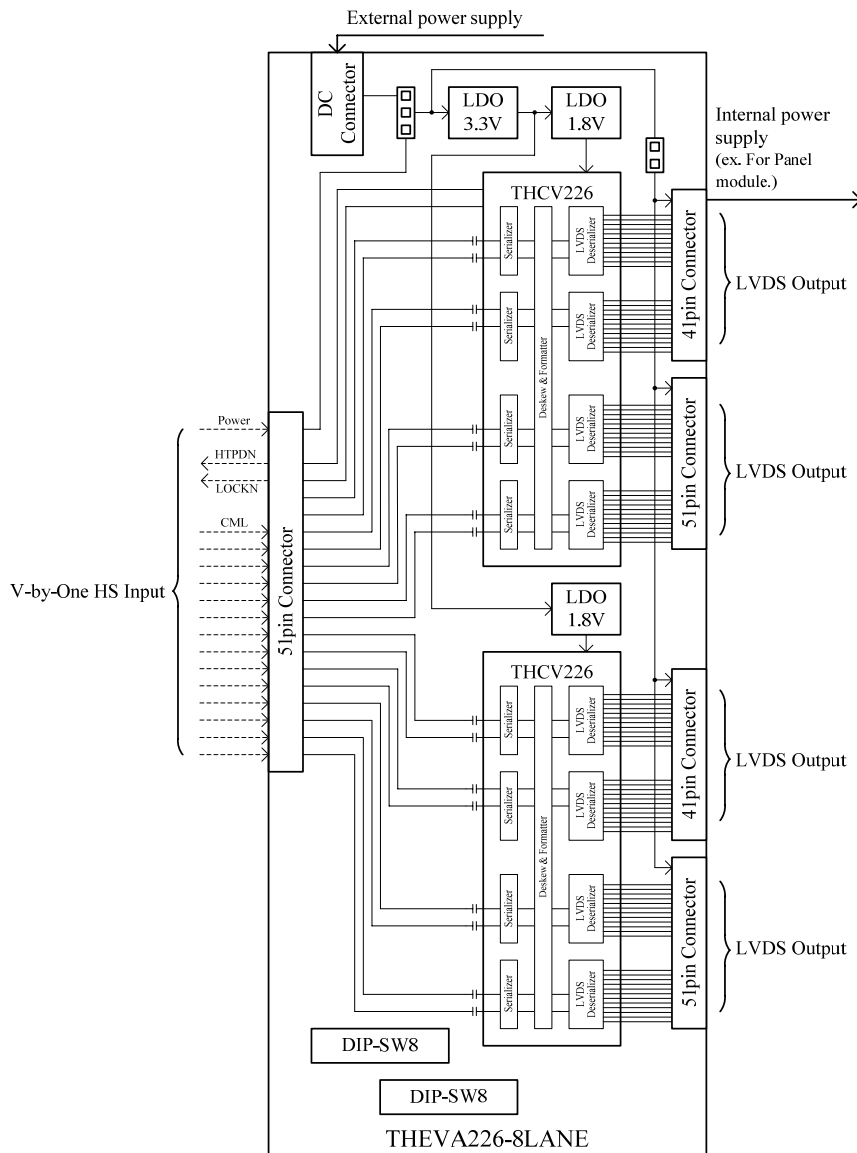

Figure2 Connection diagram

### 3. Example of Evaluation

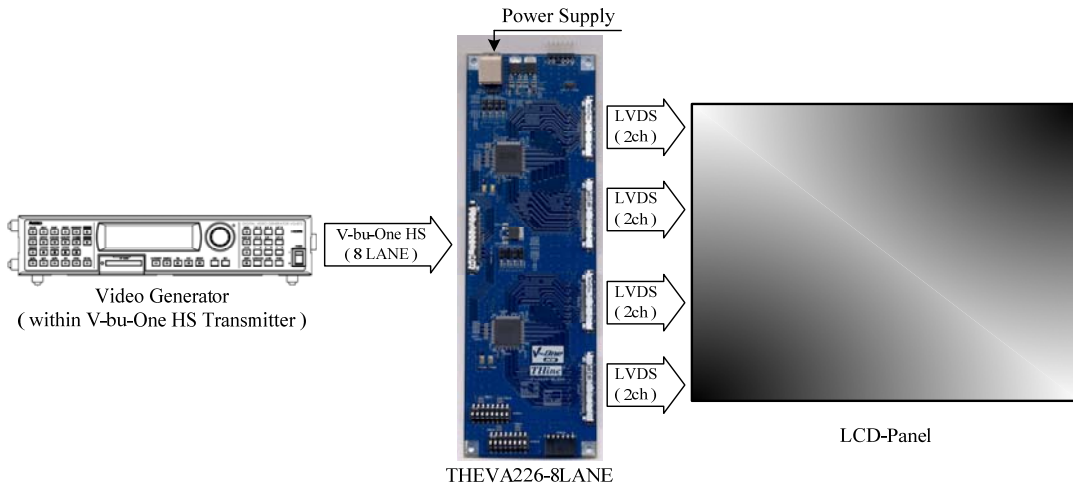

Figure3.1 Example of Evaluation 1

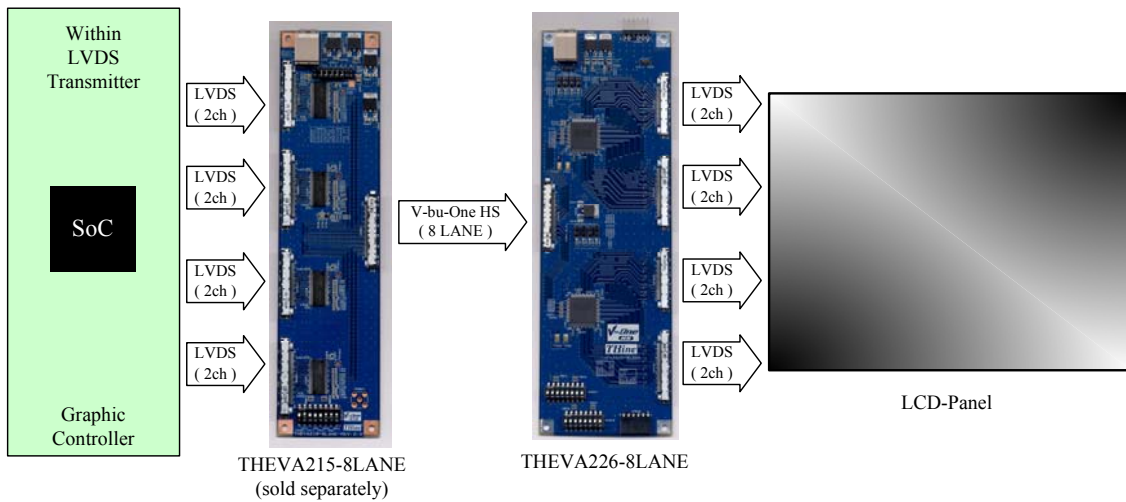

Figure3.2 Example of Evaluation 2

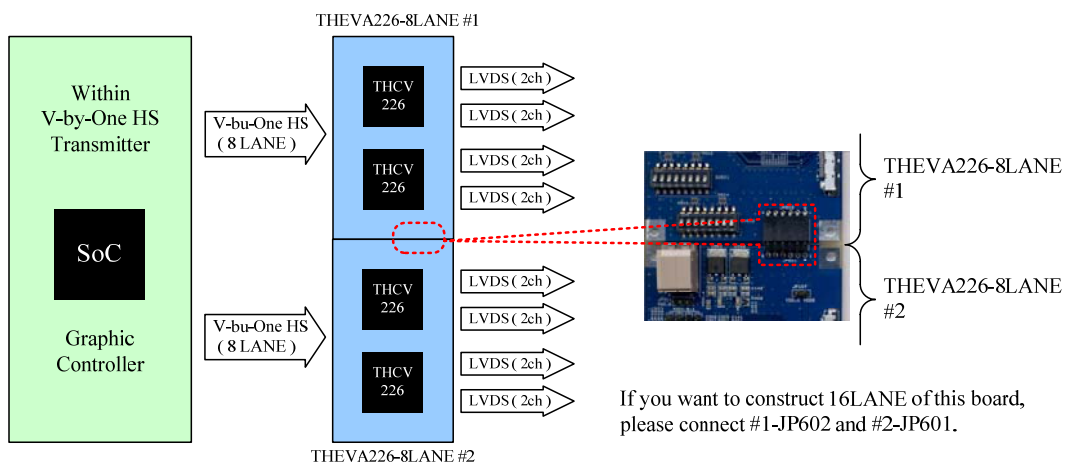

Figure3.3 Example of Evaluation 3

## 4. Connectors

This chapter shows the connector to connect the THEVA226-8LANE

Figure4.1 CN101 Pin assignments

Pin No.	Symbol	Descriptions
1	Vcc	Supply voltage from Before Board to THEVA226-4 8LANE
2		
3		
4		
5		
6		
7		
8		
9		
10		
11	GND	Ground
12		
13		
14		
15		
16	HTPDN	Hot plug detect
17	LOCKN	Lock detect
18	GND	Ground
19	Rx0n	V-by-One® HS Channel 0 (CML)
20	Rx0p	
21	GND	Ground
22	GND	
23	Rx1n	V-by-One® HS Channel 1 (CML)
24	Rx1p	
25	GND	Ground
26	GND	
27	Rx2n	V-by-One® HS Channel 2 (CML)
28	Rx2p	
29	GND	Ground
30	GND	
31	Rx3n	V-by-One® HS Channel 3 (CML)
32	Rx3p	
33	GND	Ground
34	GND	
35	Rx4n	V-by-One® HS Channel 4 (CML)
36	Rx4p	
37	GND	Ground
38	GND	
39	Rx5n	V-by-One® HS Channel 5 (CML)
40	Rx5p	
41	GND	Ground
42	GND	
43	Rx6n	V-by-One® HS Channel 6 (CML)
44	Rx6p	
45	GND	Ground
46	GND	
47	Rx7n	V-by-One® HS Channel 7 (CML)
48	Rx7p	
49	GND	Ground
50	GND	
51	NC	Non Connected

Figure4.2 CN102 and CN105 Pin assignments

Pin No.	Symbol	Descriptions
41	Vcc	Supply voltage from video processing unit, And for Panel module (Internal Supply)
40		
39		
38		
37		
36	NC	Non Connected
35	GND	Ground
34		
33		
32	RLA0-	LVDS data input/output
31	RLA0+	
30	RLB0-	
29	RLB0+	
28	RLC0-	
27	RLC0+	
26	GND	Ground
25	RLCLK0-	
24	RLCLK0+	LVDS clock input/output
23	GND	
22	RLD0-	LVDS data input/output
21	RLD0+	
20	RLE0-	
19	RLE0+	
18	GND	
17	RLA1-	LVDS data input/output
16	RLA1+	
15	RLB1-	
14	RLB1+	
13	RLC1-	
12	RLC1+	
11	GND	Ground
10	RLCLK1-	
9	RLCLK1+	LVDS clock input/output
8	GND	
7	RLD1-	LVDS data input/output
6	RLD1+	
5	RLE1-	
4	RLE1+	
3	GND	Ground
2	GND	
1	NC	Non Connected

Figure4.2 CN103 and 104 Pin assignments

Pin No.	Symbol	Descriptions
51	Vcc	Supply voltage from video processing unit, And for Panel module (Internal Supply)
50		
49		
48		
47		
46	NC	Non Connected
45	GND	Ground
44		
43		
42	RLA2-	LVDS data input/output
41	RLA2+	
40	RLB2-	
39	RLB2+	
38	RLC2-	
37	RLC2+	
36	GND	Ground
35	RLCLK2-	
34	RLCLK2+	LVDS clock input/output
33	GND	
32	RLD2-	LVDS data input/output
31	RLD2+	
30	RLE2-	
29	RLE2+	
28	GND	Ground
27	RLA3-	
26	RLA3+	LVDS data input/output
25	RLB3-	
24	RLB3+	
23	RLC3-	
22	RLC3+	
21	GND	
20	RLCLK3-	LVDS clock input/output
19	RLCLK3+	
18	GND	Ground
17	RLD3-	
16	RLD3+	LVDS data input/output
15	RLE3-	
14	RLE3+	
13	GND	
12	NC	Non Connected
11		
10		
9		
8		
7		
6		
5		
4		
3		
2		
1		

## 5. Power supplies and Transfer mode set up

This chapter shows the power supply and transfer mode setting with the jumper.

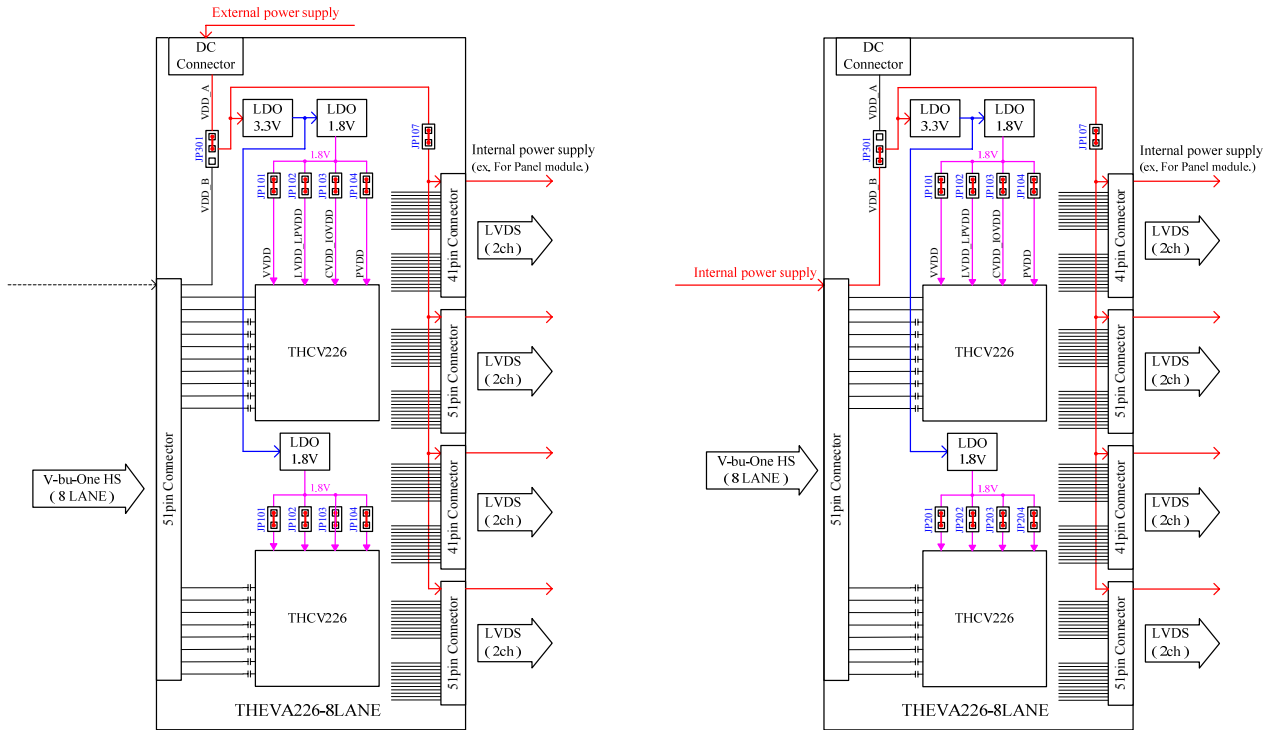

Figure5 From external/INternal power supply to after board

## 6. Other functional descriptions

This chapter shows other function.

### 6.1 LED on THEA226-8LANE

- D301: Power ON indicator.
- D401: LOCKN indicator.

## 7. DIP-SW setting

This chapter shows the DIP switches of control settings.

Table7.1 SW501 Setting

SW#	Symbol	Default Setting	Function																																																																																																																	
1	MODE2	Low	Input / Output mode select																																																																																																																	
				<table border="1"> <thead> <tr> <th>MODE2</th> <th>MODE1</th> <th>MODE0</th> <th>COL</th> <th>V-by-One HS</th> <th>LVDS</th> <th>Operation Mode</th> </tr> </thead> <tbody> <tr> <td rowspan="2">High</td> <td rowspan="2">High</td> <td rowspan="2">High</td> <td>High</td> <td>40 – 78.5MHz</td> <td>80 – 157MHz</td> <td rowspan="2">HSLVDS / Distribution mode2</td> </tr> <tr> <td>Low</td> <td>40 – 78.5MHz</td> <td>80 – 157MHz</td> </tr> <tr> <td rowspan="2">High</td> <td rowspan="2">High</td> <td rowspan="2">Low</td> <td>High</td> <td>40 – 85MHz</td> <td>40 – 85MHz</td> <td rowspan="2">Normal LVDS / Distribution mode2</td> </tr> <tr> <td>Low</td> <td>40 – 90MHz</td> <td>40 – 90MHz</td> </tr> <tr> <td rowspan="2">1</td> <td rowspan="2">MODE2</td> <td rowspan="2">Low</td> <td rowspan="2">Input / Output mode select</td> </tr> <tr> <td> <table border="1"> <tbody> <tr> <td rowspan="2">High</td> <td rowspan="2">Low</td> <td rowspan="2">High</td> <td>High</td> <td>40 – 78.5MHz</td> <td>80 – 157MHz</td> <td rowspan="2">HSLVDS / Distribution mode1</td> </tr> <tr> <td>Low</td> <td>40 – 78.5MHz</td> <td>80 – 157MHz</td> </tr> <tr> <td rowspan="2">High</td> <td rowspan="2">Low</td> <td rowspan="2">Low</td> <td>High</td> <td>40 – 85MHz</td> <td>40 – 85MHz</td> <td rowspan="2">Normal LVDS / Distribution mode1</td> </tr> <tr> <td>Low</td> <td>40 – 90MHz</td> <td>40 – 90MHz</td> </tr> <tr> <td rowspan="2">Low</td> <td rowspan="2">High</td> <td rowspan="2">High</td> <td>High</td> <td>40 – 78.5MHz</td> <td>80 – 157MHz</td> <td rowspan="2">HSLVDS / Crossing Mode</td> </tr> <tr> <td>Low</td> <td>40 – 78.5MHz</td> <td>80 – 157MHz</td> </tr> <tr> <td rowspan="2">1</td> <td rowspan="2">MODE2</td> <td rowspan="2">Low</td> <td rowspan="2">Input / Output mode select</td> </tr> <tr> <td> <table border="1"> <tbody> <tr> <td rowspan="2">Low</td> <td rowspan="2">High</td> <td rowspan="2">Low</td> <td>High</td> <td>40 – 85MHz</td> <td>40 – 85MHz</td> <td rowspan="2">Normal LVDS / Crossing mode</td> </tr> <tr> <td>Low</td> <td>40 – 90MHz</td> <td>40 – 90MHz</td> </tr> <tr> <td rowspan="2">Low</td> <td rowspan="2">Low</td> <td rowspan="2">High</td> <td>High</td> <td>40 – 78.5MHz</td> <td>80 – 157MHz</td> <td rowspan="2">HSLVDS mode</td> </tr> <tr> <td>Low</td> <td>40 – 78.5MHz</td> <td>80 – 157MHz</td> </tr> <tr> <td rowspan="2">Low</td> <td rowspan="2">Low</td> <td rowspan="2">Low</td> <td>High</td> <td>40 – 85MHz</td> <td>40 – 85MHz</td> <td rowspan="2">Normal LVDS mode</td> </tr> <tr> <td>Low</td> <td>40 – 90MHz</td> <td>40 – 90MHz</td> </tr> </tbody> </table> </td> </tr> <tr> <td>4</td> <td>OPF</td> <td>Low</td> <td>Output Pattern at CDR Fail Condition (LOCKN=1) High: LVDS output Low data Low: LVDS output Hi-Z data</td> </tr> <tr> <td>5</td> <td>COL</td> <td>High</td> <td>Color depth select High: 10 bit mode Low: 8 bit mode</td> </tr> <tr> <td>6</td> <td>OE</td> <td>High</td> <td>LVDS Output Enable High: Normal Operation Low: Output Disable</td> </tr> <tr> <td>7</td> <td>BET_SEL0</td> <td>Low</td> <td rowspan="2">Monitoring pin select</td> </tr> <tr> <td>8</td> <td>BET_SEL1</td> <td>Low</td> </tr> </tbody> </table> </td></tr></tbody></table>	MODE2	MODE1	MODE0	COL	V-by-One HS	LVDS	Operation Mode	High	High	High	High	40 – 78.5MHz	80 – 157MHz	HSLVDS / Distribution mode2	Low	40 – 78.5MHz	80 – 157MHz	High	High	Low	High	40 – 85MHz	40 – 85MHz	Normal LVDS / Distribution mode2	Low	40 – 90MHz	40 – 90MHz	1	MODE2	Low	Input / Output mode select	<table border="1"> <tbody> <tr> <td rowspan="2">High</td> <td rowspan="2">Low</td> <td rowspan="2">High</td> <td>High</td> <td>40 – 78.5MHz</td> <td>80 – 157MHz</td> <td rowspan="2">HSLVDS / Distribution mode1</td> </tr> <tr> <td>Low</td> <td>40 – 78.5MHz</td> <td>80 – 157MHz</td> </tr> <tr> <td rowspan="2">High</td> <td rowspan="2">Low</td> <td rowspan="2">Low</td> <td>High</td> <td>40 – 85MHz</td> <td>40 – 85MHz</td> <td rowspan="2">Normal LVDS / Distribution mode1</td> </tr> <tr> <td>Low</td> <td>40 – 90MHz</td> <td>40 – 90MHz</td> </tr> <tr> <td rowspan="2">Low</td> <td rowspan="2">High</td> <td rowspan="2">High</td> <td>High</td> <td>40 – 78.5MHz</td> <td>80 – 157MHz</td> <td rowspan="2">HSLVDS / Crossing Mode</td> </tr> <tr> <td>Low</td> <td>40 – 78.5MHz</td> <td>80 – 157MHz</td> </tr> <tr> <td rowspan="2">1</td> <td rowspan="2">MODE2</td> <td rowspan="2">Low</td> <td rowspan="2">Input / Output mode select</td> </tr> <tr> <td> <table border="1"> <tbody> <tr> <td rowspan="2">Low</td> <td rowspan="2">High</td> <td rowspan="2">Low</td> <td>High</td> <td>40 – 85MHz</td> <td>40 – 85MHz</td> <td rowspan="2">Normal LVDS / Crossing mode</td> </tr> <tr> <td>Low</td> <td>40 – 90MHz</td> <td>40 – 90MHz</td> </tr> <tr> <td rowspan="2">Low</td> <td rowspan="2">Low</td> <td rowspan="2">High</td> <td>High</td> <td>40 – 78.5MHz</td> <td>80 – 157MHz</td> <td rowspan="2">HSLVDS mode</td> </tr> <tr> <td>Low</td> <td>40 – 78.5MHz</td> <td>80 – 157MHz</td> </tr> <tr> <td rowspan="2">Low</td> <td rowspan="2">Low</td> <td rowspan="2">Low</td> <td>High</td> <td>40 – 85MHz</td> <td>40 – 85MHz</td> <td rowspan="2">Normal LVDS mode</td> </tr> <tr> <td>Low</td> <td>40 – 90MHz</td> <td>40 – 90MHz</td> </tr> </tbody> </table> </td> </tr> <tr> <td>4</td> <td>OPF</td> <td>Low</td> <td>Output Pattern at CDR Fail Condition (LOCKN=1) High: LVDS output Low data Low: LVDS output Hi-Z data</td> </tr> <tr> <td>5</td> <td>COL</td> <td>High</td> <td>Color depth select High: 10 bit mode Low: 8 bit mode</td> </tr> <tr> <td>6</td> <td>OE</td> <td>High</td> <td>LVDS Output Enable High: Normal Operation Low: Output Disable</td> </tr> <tr> <td>7</td> <td>BET_SEL0</td> <td>Low</td> <td rowspan="2">Monitoring pin select</td> </tr> <tr> <td>8</td> <td>BET_SEL1</td> <td>Low</td> </tr> </tbody> </table>	High	Low	High	High	40 – 78.5MHz	80 – 157MHz	HSLVDS / Distribution mode1	Low	40 – 78.5MHz	80 – 157MHz	High	Low	Low	High	40 – 85MHz	40 – 85MHz	Normal LVDS / Distribution mode1	Low	40 – 90MHz	40 – 90MHz	Low	High	High	High	40 – 78.5MHz	80 – 157MHz	HSLVDS / Crossing Mode	Low	40 – 78.5MHz	80 – 157MHz	1	MODE2	Low	Input / Output mode select	<table border="1"> <tbody> <tr> <td rowspan="2">Low</td> <td rowspan="2">High</td> <td rowspan="2">Low</td> <td>High</td> <td>40 – 85MHz</td> <td>40 – 85MHz</td> <td rowspan="2">Normal LVDS / Crossing mode</td> </tr> <tr> <td>Low</td> <td>40 – 90MHz</td> <td>40 – 90MHz</td> </tr> <tr> <td rowspan="2">Low</td> <td rowspan="2">Low</td> <td rowspan="2">High</td> <td>High</td> <td>40 – 78.5MHz</td> <td>80 – 157MHz</td> <td rowspan="2">HSLVDS mode</td> </tr> <tr> <td>Low</td> <td>40 – 78.5MHz</td> <td>80 – 157MHz</td> </tr> <tr> <td rowspan="2">Low</td> <td rowspan="2">Low</td> <td rowspan="2">Low</td> <td>High</td> <td>40 – 85MHz</td> <td>40 – 85MHz</td> <td rowspan="2">Normal LVDS mode</td> </tr> <tr> <td>Low</td> <td>40 – 90MHz</td> <td>40 – 90MHz</td> </tr> </tbody> </table>	Low	High	Low	High	40 – 85MHz	40 – 85MHz	Normal LVDS / Crossing mode	Low	40 – 90MHz	40 – 90MHz	Low	Low	High	High	40 – 78.5MHz	80 – 157MHz	HSLVDS mode	Low	40 – 78.5MHz	80 – 157MHz	Low	Low	Low	High	40 – 85MHz	40 – 85MHz	Normal LVDS mode	Low	40 – 90MHz	40 – 90MHz	4	OPF	Low	Output Pattern at CDR Fail Condition (LOCKN=1) High: LVDS output Low data Low: LVDS output Hi-Z data	5	COL	High	Color depth select High: 10 bit mode Low: 8 bit mode	6	OE	High	LVDS Output Enable High: Normal Operation Low: Output Disable	7	BET_SEL0	Low
MODE2	MODE1	MODE0	COL	V-by-One HS	LVDS	Operation Mode																																																																																																														
High	High	High	High	40 – 78.5MHz	80 – 157MHz	HSLVDS / Distribution mode2																																																																																																														
			Low	40 – 78.5MHz	80 – 157MHz																																																																																																															
High	High	Low	High	40 – 85MHz	40 – 85MHz	Normal LVDS / Distribution mode2																																																																																																														
			Low	40 – 90MHz	40 – 90MHz																																																																																																															
1	MODE2	Low	Input / Output mode select																																																																																																																	
				<table border="1"> <tbody> <tr> <td rowspan="2">High</td> <td rowspan="2">Low</td> <td rowspan="2">High</td> <td>High</td> <td>40 – 78.5MHz</td> <td>80 – 157MHz</td> <td rowspan="2">HSLVDS / Distribution mode1</td> </tr> <tr> <td>Low</td> <td>40 – 78.5MHz</td> <td>80 – 157MHz</td> </tr> <tr> <td rowspan="2">High</td> <td rowspan="2">Low</td> <td rowspan="2">Low</td> <td>High</td> <td>40 – 85MHz</td> <td>40 – 85MHz</td> <td rowspan="2">Normal LVDS / Distribution mode1</td> </tr> <tr> <td>Low</td> <td>40 – 90MHz</td> <td>40 – 90MHz</td> </tr> <tr> <td rowspan="2">Low</td> <td rowspan="2">High</td> <td rowspan="2">High</td> <td>High</td> <td>40 – 78.5MHz</td> <td>80 – 157MHz</td> <td rowspan="2">HSLVDS / Crossing Mode</td> </tr> <tr> <td>Low</td> <td>40 – 78.5MHz</td> <td>80 – 157MHz</td> </tr> <tr> <td rowspan="2">1</td> <td rowspan="2">MODE2</td> <td rowspan="2">Low</td> <td rowspan="2">Input / Output mode select</td> </tr> <tr> <td> <table border="1"> <tbody> <tr> <td rowspan="2">Low</td> <td rowspan="2">High</td> <td rowspan="2">Low</td> <td>High</td> <td>40 – 85MHz</td> <td>40 – 85MHz</td> <td rowspan="2">Normal LVDS / Crossing mode</td> </tr> <tr> <td>Low</td> <td>40 – 90MHz</td> <td>40 – 90MHz</td> </tr> <tr> <td rowspan="2">Low</td> <td rowspan="2">Low</td> <td rowspan="2">High</td> <td>High</td> <td>40 – 78.5MHz</td> <td>80 – 157MHz</td> <td rowspan="2">HSLVDS mode</td> </tr> <tr> <td>Low</td> <td>40 – 78.5MHz</td> <td>80 – 157MHz</td> </tr> <tr> <td rowspan="2">Low</td> <td rowspan="2">Low</td> <td rowspan="2">Low</td> <td>High</td> <td>40 – 85MHz</td> <td>40 – 85MHz</td> <td rowspan="2">Normal LVDS mode</td> </tr> <tr> <td>Low</td> <td>40 – 90MHz</td> <td>40 – 90MHz</td> </tr> </tbody> </table> </td> </tr> <tr> <td>4</td> <td>OPF</td> <td>Low</td> <td>Output Pattern at CDR Fail Condition (LOCKN=1) High: LVDS output Low data Low: LVDS output Hi-Z data</td> </tr> <tr> <td>5</td> <td>COL</td> <td>High</td> <td>Color depth select High: 10 bit mode Low: 8 bit mode</td> </tr> <tr> <td>6</td> <td>OE</td> <td>High</td> <td>LVDS Output Enable High: Normal Operation Low: Output Disable</td> </tr> <tr> <td>7</td> <td>BET_SEL0</td> <td>Low</td> <td rowspan="2">Monitoring pin select</td> </tr> <tr> <td>8</td> <td>BET_SEL1</td> <td>Low</td> </tr> </tbody> </table>	High	Low	High	High	40 – 78.5MHz	80 – 157MHz	HSLVDS / Distribution mode1	Low	40 – 78.5MHz	80 – 157MHz	High	Low	Low	High	40 – 85MHz	40 – 85MHz	Normal LVDS / Distribution mode1	Low	40 – 90MHz	40 – 90MHz	Low	High	High	High	40 – 78.5MHz	80 – 157MHz	HSLVDS / Crossing Mode	Low	40 – 78.5MHz	80 – 157MHz	1	MODE2	Low	Input / Output mode select	<table border="1"> <tbody> <tr> <td rowspan="2">Low</td> <td rowspan="2">High</td> <td rowspan="2">Low</td> <td>High</td> <td>40 – 85MHz</td> <td>40 – 85MHz</td> <td rowspan="2">Normal LVDS / Crossing mode</td> </tr> <tr> <td>Low</td> <td>40 – 90MHz</td> <td>40 – 90MHz</td> </tr> <tr> <td rowspan="2">Low</td> <td rowspan="2">Low</td> <td rowspan="2">High</td> <td>High</td> <td>40 – 78.5MHz</td> <td>80 – 157MHz</td> <td rowspan="2">HSLVDS mode</td> </tr> <tr> <td>Low</td> <td>40 – 78.5MHz</td> <td>80 – 157MHz</td> </tr> <tr> <td rowspan="2">Low</td> <td rowspan="2">Low</td> <td rowspan="2">Low</td> <td>High</td> <td>40 – 85MHz</td> <td>40 – 85MHz</td> <td rowspan="2">Normal LVDS mode</td> </tr> <tr> <td>Low</td> <td>40 – 90MHz</td> <td>40 – 90MHz</td> </tr> </tbody> </table>	Low	High	Low	High	40 – 85MHz	40 – 85MHz	Normal LVDS / Crossing mode	Low	40 – 90MHz	40 – 90MHz	Low	Low	High	High	40 – 78.5MHz	80 – 157MHz	HSLVDS mode	Low	40 – 78.5MHz	80 – 157MHz	Low	Low	Low	High	40 – 85MHz	40 – 85MHz	Normal LVDS mode	Low	40 – 90MHz	40 – 90MHz	4	OPF	Low	Output Pattern at CDR Fail Condition (LOCKN=1) High: LVDS output Low data Low: LVDS output Hi-Z data	5	COL	High	Color depth select High: 10 bit mode Low: 8 bit mode	6	OE	High	LVDS Output Enable High: Normal Operation Low: Output Disable	7	BET_SEL0	Low	Monitoring pin select	8	BET_SEL1	Low																												
High	Low	High	High	40 – 78.5MHz				80 – 157MHz	HSLVDS / Distribution mode1																																																																																																											
			Low	40 – 78.5MHz	80 – 157MHz																																																																																																															
High	Low	Low	High	40 – 85MHz	40 – 85MHz	Normal LVDS / Distribution mode1																																																																																																														
			Low	40 – 90MHz	40 – 90MHz																																																																																																															
Low	High	High	High	40 – 78.5MHz	80 – 157MHz	HSLVDS / Crossing Mode																																																																																																														
			Low	40 – 78.5MHz	80 – 157MHz																																																																																																															
1	MODE2	Low	Input / Output mode select																																																																																																																	
				<table border="1"> <tbody> <tr> <td rowspan="2">Low</td> <td rowspan="2">High</td> <td rowspan="2">Low</td> <td>High</td> <td>40 – 85MHz</td> <td>40 – 85MHz</td> <td rowspan="2">Normal LVDS / Crossing mode</td> </tr> <tr> <td>Low</td> <td>40 – 90MHz</td> <td>40 – 90MHz</td> </tr> <tr> <td rowspan="2">Low</td> <td rowspan="2">Low</td> <td rowspan="2">High</td> <td>High</td> <td>40 – 78.5MHz</td> <td>80 – 157MHz</td> <td rowspan="2">HSLVDS mode</td> </tr> <tr> <td>Low</td> <td>40 – 78.5MHz</td> <td>80 – 157MHz</td> </tr> <tr> <td rowspan="2">Low</td> <td rowspan="2">Low</td> <td rowspan="2">Low</td> <td>High</td> <td>40 – 85MHz</td> <td>40 – 85MHz</td> <td rowspan="2">Normal LVDS mode</td> </tr> <tr> <td>Low</td> <td>40 – 90MHz</td> <td>40 – 90MHz</td> </tr> </tbody> </table>	Low	High	Low	High	40 – 85MHz	40 – 85MHz	Normal LVDS / Crossing mode	Low	40 – 90MHz	40 – 90MHz	Low	Low	High	High	40 – 78.5MHz	80 – 157MHz	HSLVDS mode	Low	40 – 78.5MHz	80 – 157MHz	Low	Low	Low	High	40 – 85MHz	40 – 85MHz	Normal LVDS mode	Low	40 – 90MHz	40 – 90MHz																																																																																		
Low	High	Low	High	40 – 85MHz				40 – 85MHz	Normal LVDS / Crossing mode																																																																																																											
			Low	40 – 90MHz	40 – 90MHz																																																																																																															
Low	Low	High	High	40 – 78.5MHz	80 – 157MHz	HSLVDS mode																																																																																																														
			Low	40 – 78.5MHz	80 – 157MHz																																																																																																															
Low	Low	Low	High	40 – 85MHz	40 – 85MHz	Normal LVDS mode																																																																																																														
			Low	40 – 90MHz	40 – 90MHz																																																																																																															
4	OPF	Low	Output Pattern at CDR Fail Condition (LOCKN=1) High: LVDS output Low data Low: LVDS output Hi-Z data																																																																																																																	
5	COL	High	Color depth select High: 10 bit mode Low: 8 bit mode																																																																																																																	
6	OE	High	LVDS Output Enable High: Normal Operation Low: Output Disable																																																																																																																	
7	BET_SEL0	Low	Monitoring pin select																																																																																																																	
8	BET_SEL1	Low																																																																																																																		

\* Please see the datasheet for details. ( THCV226\_Rev.x.xx\_E.pdf )

Table7.2 SW502 Setting

SW#	Symbol	Default Setting	Function
1	MON_EN	Low	Monitoring mode enable High: Monitoring enable Low: Monitoring disable
2	BET_EN	Low	Field-BET enable High: Enable Low: Normal operation
3	BET_LAT	Low	Latch select input under Field BET operation High: Latched result output Low: Reset latched result
4	PRBS	Low	Must be tied to GND
5	RS	High	LVDS swing level select High: Normal swing (350mV) Low: Reduced swing (200mV)
6	MAP	High	LVDS output format select High: JEIDA format Low: VESA format
7	PDN1	High	Power down High: Normal operation Low: Power down operation
8	PDN2	High	

\* Please see the datasheet for details. ( THCV226\_Rev.x.xx\_E.pdf )

**8. Schematic**

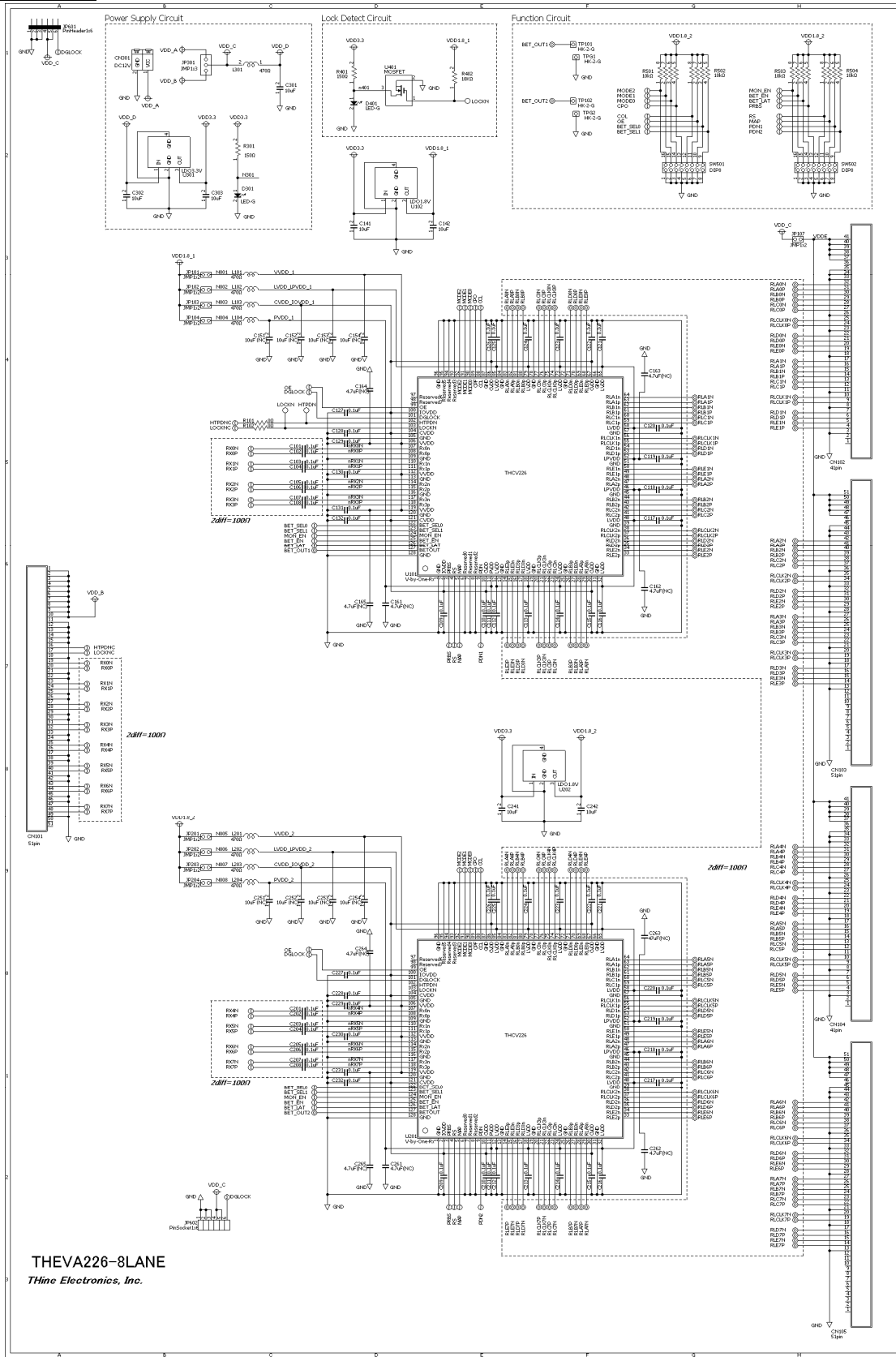

Figure8 Evaluation board schematic

## 9. Bills of Materials

Table9 Evaluation board BOM

Designator	Description	Size	PartNumber	Manufacturer	Designator	Description	Size	PartNumber	Manufacturer
C101	0.1uF	1005	GRM155B31C104KA87	Murata	C301	10uF	2012	GRM21BB31C106KE15	Murata
C102	0.1uF	1005	GRM155B31C104KA87	Murata	C302	10uF	2012	GRM21BB31C106KE15	Murata
C103	0.1uF	1005	GRM155B31C104KA87	Murata	C303	10uF	2012	GRM21BB31C106KE15	Murata
C104	0.1uF	1005	GRM155B31C104KA87	Murata	CN101	51pin	3804	FX16-51S-0.5SH	HRS
C105	0.1uF	1005	GRM155B31C104KA87	Murata	CN102	41pin	3404	FX15SC-41S-0.5SH	HRS
C106	0.1uF	1005	GRM155B31C104KA87	Murata	CN103	51pin	3804	FX15SC-51S-0.5SH	HRS
C107	0.1uF	1005	GRM155B31C104KA87	Murata	CN104	41pin	3404	FX15SC-41S-0.5SH	HRS
C108	0.1uF	1005	GRM155B31C104KA87	Murata	CN105	51pin	3804	FX15SC-51S-0.5SH	HRS
C109	0.1uF	1005	GRM155B31C104KA87	Murata	CN301	DC12V	1105	ML-800-S1H-2P	Sato-parts
C110	0.1uF	1005	GRM155B31C104KA87	Murata	CN901	FI-X30SSLB-HF(NC-		FI-X30SSLB-HF	JAE
C111	0.1uF	1005	GRM155B31C104KA87	Murata	CN902	FI-X30SSLB-HF(NC-		FI-X30SSLB-HF	JAE
C112	0.1uF	1005	GRM155B31C104KA87	Murata	CN903	FI-X30SSLB-HF(NC-		FI-X30SSLB-HF	JAE
C113	0.1uF	1005	GRM155B31C104KA87	Murata	CN904	FI-X30SSLB-HF(NC-		FI-X30SSLB-HF	JAE
C114	0.1uF	1005	GRM155B31C104KA87	Murata	D301	LED-G	1608	SML-310MT	ROHM
C115	0.1uF	1005	GRM155B31C104KA87	Murata	D401	LED-G	1608	SML-310MT	ROHM
C116	0.1uF	1005	GRM155B31C104KA87	Murata	JP101	JMP1x2	2.54mm	1*2-PinHeaders	-
C117	0.1uF	1005	GRM155B31C104KA87	Murata	JP102	JMP1x2	2.54mm	1*2-PinHeaders	-
C118	0.1uF	1005	GRM155B31C104KA87	Murata	JP103	JMP1x2	2.54mm	1*2-PinHeaders	-
C119	0.1uF	1005	GRM155B31C104KA87	Murata	JP104	JMP1x2	2.54mm	1*2-PinHeaders	-
C120	0.1uF	1005	GRM155B31C104KA87	Murata	JP107	JMP1x2	2.54mm	1*2-PinHeaders	-
C121	0.1uF	1005	GRM155B31C104KA87	Murata	JP201	JMP1x2	2.54mm	1*2-PinHeaders	-
C122	0.1uF	1005	GRM155B31C104KA87	Murata	JP202	JMP1x2	2.54mm	1*2-PinHeaders	-
C123	0.1uF	1005	GRM155B31C104KA87	Murata	JP203	JMP1x2	2.54mm	1*2-PinHeaders	-
C124	0.1uF	1005	GRM155B31C104KA87	Murata	JP204	JMP1x2	2.54mm	1*2-PinHeaders	-
C125	0.1uF	1005	GRM155B31C104KA87	Murata	JP301	JMP1x3	2.54mm	1*3-PinHeaders	-
C126	0.1uF	1005	GRM155B31C104KA87	Murata	JP601	PinHeader1x6	2.54mm	C-05336	Akizuki
C127	0.1uF	1005	GRM155B31C104KA87	Murata	JP602	PinSocket1x6	2.54mm	C-03795	Akizuki
C128	0.1uF	1005	GRM155B31C104KA87	Murata	L101	470Ω	1608	MPZ1608B471ATA00	TDK
C129	0.1uF	1005	GRM155B31C104KA87	Murata	L102	470Ω	1608	MPZ1608B471ATA00	TDK
C130	0.1uF	1005	GRM155B31C104KA87	Murata	L103	470Ω	1608	MPZ1608B471ATA00	TDK
C131	0.1uF	1005	GRM155B31C104KA87	Murata	L104	470Ω	1608	MPZ1608B471ATA00	TDK
C132	0.1uF	1005	GRM155B31C104KA87	Murata	L201	470Ω	1608	MPZ1608B471ATA00	TDK
C141	10uF	2012	GRM21BB31C106KE15	Murata	L202	470Ω	1608	MPZ1608B471ATA00	TDK
C142	10uF	2012	GRM21BB31C106KE15	Murata	L203	470Ω	1608	MPZ1608B471ATA00	TDK
C151	10uF(NC)	2012	GRM21BB31C106KE15	Murata	L204	470Ω	1608	MPZ1608B471ATA00	TDK
C152	10uF(NC)	2012	GRM21BB31C106KE15	Murata	L301	470Ω	1608	MPZ1608B471ATA00	TDK
C153	10uF(NC)	2012	GRM21BB31C106KE15	Murata	R101	0Ω	1608	RK73Z1JTBK	KOA
C154	10uF(NC)	2012	GRM21BB31C106KE15	Murata	R102	0Ω	1608	RK73Z1JTBK	KOA
C161	4.7uF(NC)	1608	GRM185B31C475KE43	Murata	R301	150Ω	1608	RK73B1JBK151J	KOA
C162	4.7uF(NC)	1608	GRM185B31C475KE43	Murata	R401	150Ω	1608	RK73B1JBK151J	KOA
C163	4.7uF(NC)	1608	GRM185B31C475KE43	Murata	R402	10KΩ	1608	RK73B1JBK103J	KOA
C164	4.7uF(NC)	1608	GRM185B31C475KE43	Murata	R501	10kΩ	2010	CN1E4KTBK103J	KOA
C165	4.7uF(NC)	1608	GRM185B31C475KE43	Murata	R502	10kΩ	2010	CN1E4KTBK103J	KOA
C201	0.1uF	1005	GRM155B31C104KA87	Murata	R503	10kΩ	2010	CN1E4KTBK103J	KOA
C202	0.1uF	1005	GRM155B31C104KA87	Murata	R504	10kΩ	2010	CN1E4KTBK103J	KOA
C203	0.1uF	1005	GRM155B31C104KA87	Murata	R911	0Ω(NC)	3216	CNZ1J4	KOA
C204	0.1uF	1005	GRM155B31C104KA87	Murata	R912	0Ω(NC)	3216	CNZ1J4	KOA
C205	0.1uF	1005	GRM155B31C104KA87	Murata	R913	0Ω(NC)	3216	CNZ1J4	KOA
C206	0.1uF	1005	GRM155B31C104KA87	Murata	R914	0Ω(NC)	3216	CNZ1J4	KOA
C207	0.1uF	1005	GRM155B31C104KA87	Murata	R915	0Ω(NC)	3216	CNZ1J4	KOA
C208	0.1uF	1005	GRM155B31C104KA87	Murata	R916	0Ω(NC)	3216	CNZ1J4	KOA
C209	0.1uF	1005	GRM155B31C104KA87	Murata	R921	0Ω(NC)	3216	CNZ1J4	KOA
C210	0.1uF	1005	GRM155B31C104KA87	Murata	R922	0Ω(NC)	3216	CNZ1J4	KOA
C211	0.1uF	1005	GRM155B31C104KA87	Murata	R923	0Ω(NC)	3216	CNZ1J4	KOA
C212	0.1uF	1005	GRM155B31C104KA87	Murata	R924	0Ω(NC)	3216	CNZ1J4	KOA
C213	0.1uF	1005	GRM155B31C104KA87	Murata	R925	0Ω(NC)	3216	CNZ1J4	KOA
C214	0.1uF	1005	GRM155B31C104KA87	Murata	R926	0Ω(NC)	3216	CNZ1J4	KOA
C215	0.1uF	1005	GRM155B31C104KA87	Murata	R931	0Ω(NC)	3216	CNZ1J4	KOA
C216	0.1uF	1005	GRM155B31C104KA87	Murata	R932	0Ω(NC)	3216	CNZ1J4	KOA
C217	0.1uF	1005	GRM155B31C104KA87	Murata	R933	0Ω(NC)	3216	CNZ1J4	KOA
C218	0.1uF	1005	GRM155B31C104KA87	Murata	R934	0Ω(NC)	3216	CNZ1J4	KOA
C219	0.1uF	1005	GRM155B31C104KA87	Murata	R935	0Ω(NC)	3216	CNZ1J4	KOA
C220	0.1uF	1005	GRM155B31C104KA87	Murata	R936	0Ω(NC)	3216	CNZ1J4	KOA
C221	0.1uF	1005	GRM155B31C104KA87	Murata	R941	0Ω(NC)	3216	CNZ1J4	KOA
C222	0.1uF	1005	GRM155B31C104KA87	Murata	R942	0Ω(NC)	3216	CNZ1J4	KOA
C223	0.1uF	1005	GRM155B31C104KA87	Murata	R943	0Ω(NC)	3216	CNZ1J4	KOA
C224	0.1uF	1005	GRM155B31C104KA87	Murata	R944	0Ω(NC)	3216	CNZ1J4	KOA
C225	0.1uF	1005	GRM155B31C104KA87	Murata	R945	0Ω(NC)	3216	CNZ1J4	KOA
C226	0.1uF	1005	GRM155B31C104KA87	Murata	R946	0Ω(NC)	3216	CNZ1J4	KOA
C227	0.1uF	1005	GRM155B31C104KA87	Murata	SW501	DIP8	2206	A6S-8104-H	Omuron
C228	0.1uF	1005	GRM155B31C104KA87	Murata	SW502	DIP8	2206	A6S-8104-H	Omuron
C229	0.1uF	1005	GRM155B31C104KA87	Murata	TP101	HK-2-G	3216	HK-2-G	Mac8
C230	0.1uF	1005	GRM155B31C104KA87	Murata	TP102	HK-2-G	3216	HK-2-G	Mac8
C231	0.1uF	1005	GRM155B31C104KA87	Murata	TPG1	HK-2-G	3216	HK-2-G	Mac8
C232	0.1uF	1005	GRM155B31C104KA87	Murata	TPG2	HK-2-G	3216	HK-2-G	Mac8
C241	10uF	2012	GRM21BB31C106KE15	Murata	U101	V-by-One-Rx	TQFP128	THCV226	THine
C242	10uF	2012	GRM21BB31C106KE15	Murata	U102	LDO1.8V	SC-63	uPC2918BT-AZ	NEC
C251	10uF(NC)	2012	GRM21BB31C106KE15	Murata	U201	V-by-One-Rx	TQFP128	THCV226	THine
C252	10uF(NC)	2012	GRM21BB31C106KE15	Murata	U202	LDO1.8V	SC-63	uPC2918BT-AZ	NEC
C253	10uF(NC)	2012	GRM21BB31C106KE15	Murata	U301	LDO3.3V	SC-63	uPC2933BT-AZ	NEC
C254	10uF(NC)	2012	GRM21BB31C106KE15	Murata	U401	MOSFET	1616	SSM3K16FS	Toshiba
C261	4.7uF(NC)	1608	GRM185B31C475KE43	Murata					
C262	4.7uF(NC)	1608	GRM185B31C475KE43	Murata					
C263	47uF(NC)	1608	GRM185B31C475KE43	Murata					
C264	4.7uF(NC)	1608	GRM185B31C475KE43	Murata					
C265	4.7uF(NC)	1608	GRM185B31C475KE43	Murata					

### 10. Layout

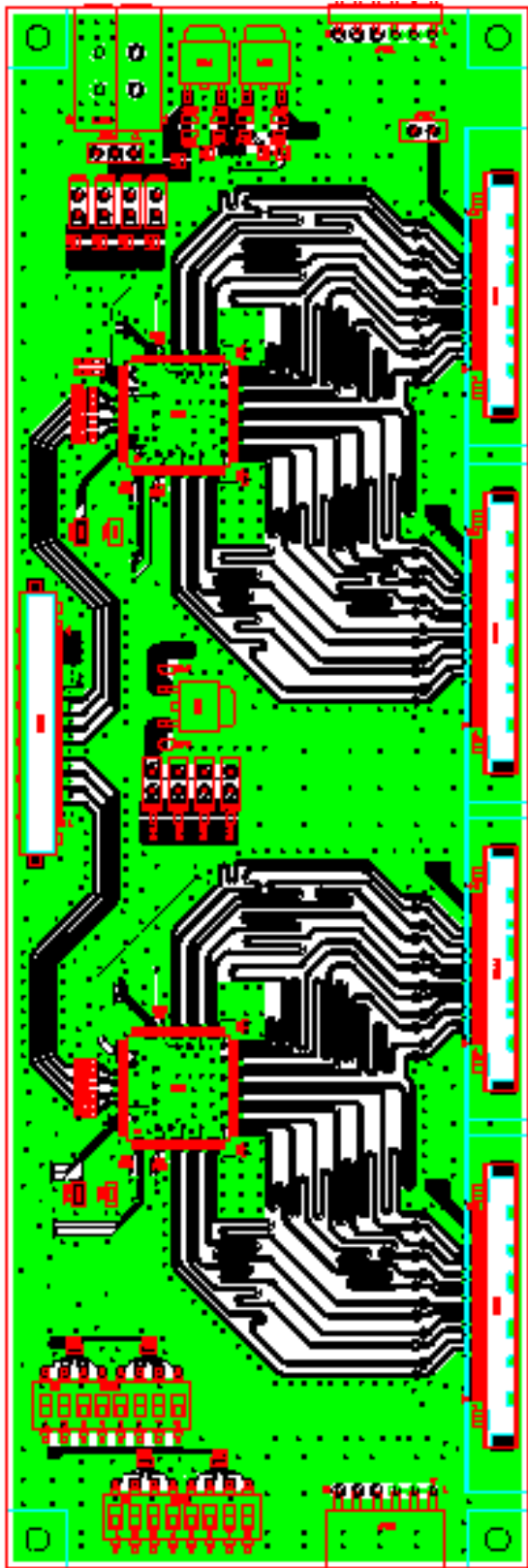

Figure10.1 COMPONENT SIDE – LAYER 1

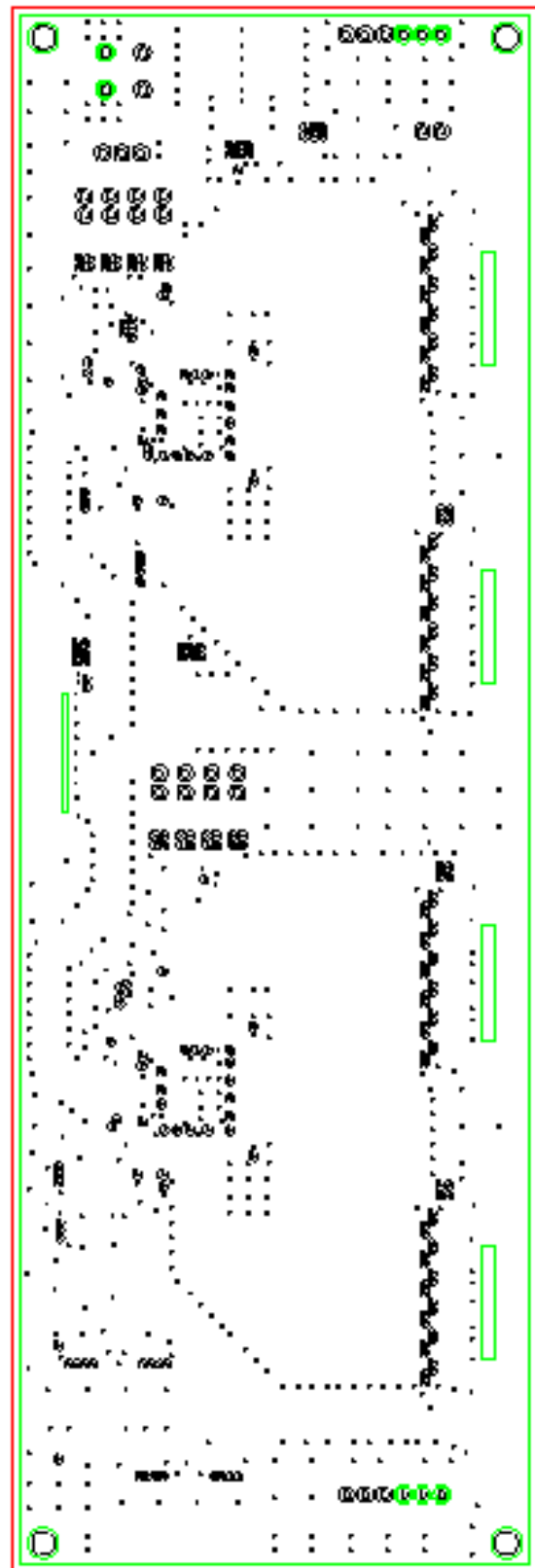

Figure10.2 GROUND PLANE – LAYER 2



10. Layout ( Continued )

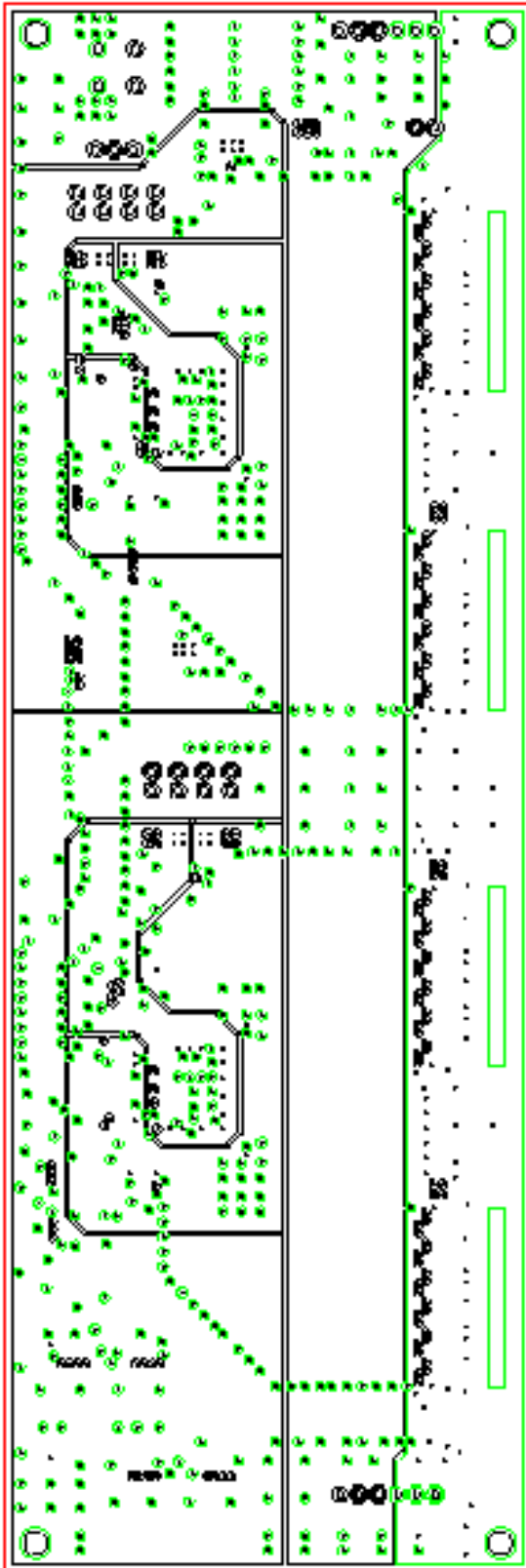

Figure10.3 POWER PLANE – LAYER 3

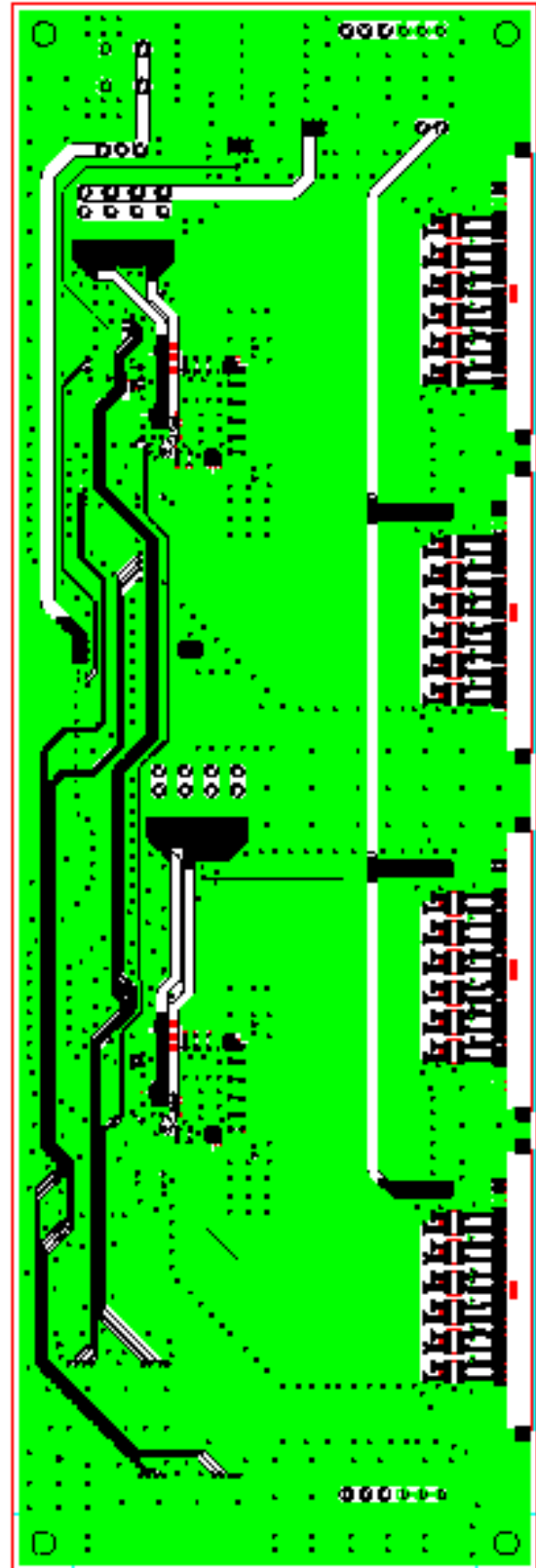
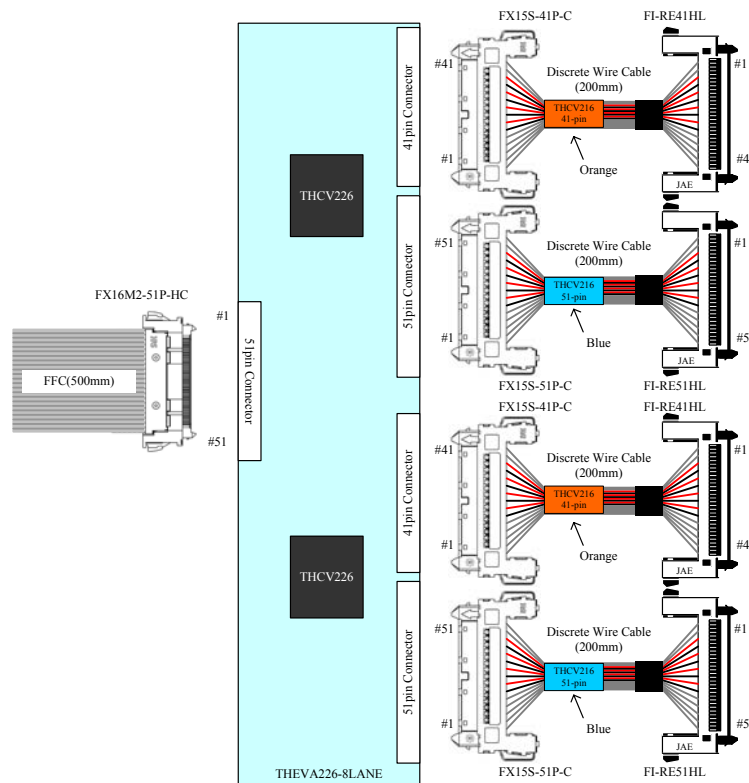

Figure10.2 SOLDER SIDE – LAYER 4

## 11. Set items



## 12. Notices and Requests

1. The product specifications described in this material are subject to change without prior notice.
2. The circuit diagrams described in this material are examples of the application which may not always apply to the customer's design. We are not responsible for possible errors and omissions in this material. Please note if errors or omissions should be found in this material, we may not be able to correct them immediately.
3. This material contains our copyright, know-how or other proprietary. Copying or disclosing to third parties the contents of this material without our prior permission is prohibited.
4. Note that if infringement of any third party's industrial ownership should occur by using this product, we will be exempted from the responsibility unless it directly relates to the production process or functions of the product.
5. This product is presumed to be used for general electric equipment, not for the applications which require very high reliability (including medical equipment directly concerning people's life, aerospace equipment, or nuclear control equipment). Also, when using this product for the equipment concerned with the control and safety of the transportation means, the traffic signal equipment, or various Types of safety equipment, please do it after applying appropriate measures to the product.
6. Despite our utmost efforts to improve the quality and reliability of the product, faults will occur with a certain small probability, which is inevitable to a semi-conductor product. Therefore, you are encouraged to have sufficiently redundant or error preventive design applied to the use of the product so as not to have our product cause any social or public damage.
7. Please note that this product is not designed to be radiation-proof.
8. Customers are asked, if required, to judge by themselves if this product falls under the category of strategic goods under the Foreign Exchange and Foreign Trade Control Law.

**THine Electronics, Inc.**

sales@thine.co.jp