

Hybrid motor starter - ELR H51-IESSC-24DC500AC-9 - 2902745

Please be informed that the data shown in this PDF Document is generated from our Online Catalog. Please find the complete data in the user's documentation. Our General Terms of Use for Downloads are valid (<http://phoenixcontact.com/download>)



Short-circuit-proof hybrid motor starter for reversing 3~ AC motors up to 550 V AC, with 24 V DC input, 9 A output current, emergency stop function, and adjustable overload shutdown. Can only be used with EM-RD adapter, EM-RI adapter or power distribution board.

Your advantages

- 22.5 mm wide
- Safety level according to IEC 61508-1: SIL 3, ISO 13849: PL e
- Reduction in wiring
- Long service life
- Space saving
- Adjustable current for bimetal function
- Low-wear switching



Key Commercial Data

Packing unit	1 pc
GTIN	
GTIN	4046356673631

Technical data

Dimensions

Width	22.5 mm
Height	160 mm
Depth	114.5 mm

Ambient conditions

Ambient temperature (operation)	-25 °C ... 70 °C (observe derating)
Ambient temperature (storage/transport)	-40 °C ... 80 °C
Maximum altitude	≤ 2000 m
Degree of protection	IP20

Device supply

Hybrid motor starter - ELR H51-IESSC-24DC500AC-9 - 2902745

Technical data

Device supply

Rated control circuit supply voltage U_s	24 V DC
Control supply voltage range	19.2 V DC ... 30 V DC
Rated control supply current I_s	40 mA
Type of protection	Surge protection
	Reverse polarity protection

Input data

Input name	Control input right/left
Rated actuating voltage U_c	24 V DC
Triggering voltage range	19.2 V DC ... 30 V DC
Rated actuating current I_c	5 mA
Switching threshold	9.6 V ("0" signal)
	19.2 V ("1" signal)
Switching level	< 5 V DC (For EMERGENCY STOP)
Typical turn-off time	< 30 ms
Type of protection	Reverse polarity protection

Output data load output

Output name	AC output
Rated operating voltage U_e	500 V AC
Operating voltage range	42 V AC ... 550 V AC
Mains frequency	50/60 Hz
Load current range	1.5 A ... 9 A (see to derating)
Trigger characteristic in acc. with IEC 60947-4-2	Class 10A
Cooling time	20 min. (for auto reset)
Leakage current	0 mA
Type of protection	Surge protection
	Short-circuit protection

Output data reply output

Output name	Acknowledge output
Note	Confirmation: floating change-over contact, signal contact
Contact type	1 PDT
Switching capacity according to IEC 60947-5-1	3 A (230 V, AC15)
	2 A (24 V, DC13)

Overspeed tripping

Operate threshold	> 45 A
Response time	< 2 s

General

Motor starter type	Reversing starter
Switching frequency	\leq 2 Hz (Load-dependent)

Hybrid motor starter - ELR H51-IESSC-24DC500AC-9 - 2902745

Technical data

General

Mounting position	vertical (horizontal DIN rail, motor output below)
Mounting type	DIN rail mounting
Assembly instructions	alignable, for spacing see derating
Operating mode	100% operating factor
Maximum power dissipation	12 W
Minimum power dissipation	0.88 W
Operating voltage display	Green LED
Status display	Yellow LED
Indication	Red LED

Connection data

Connection name	Control circuits
Connection method	Screw connection
Stripping length	8 mm
Screw thread	M3
Conductor cross section solid	0.2 mm ² ... 2.5 mm ²
Conductor cross section flexible	0.2 mm ² ... 2.5 mm ²
Conductor cross section AWG	24 ... 14
Torque	0.5 Nm ... 0.6 Nm

Connection data 2

Connection name	Load circuit
Connection method	Screw connection
Stripping length	8 mm
Screw thread	M3
Conductor cross section solid	0.2 mm ² ... 2.5 mm ²
Conductor cross section flexible	0.2 mm ² ... 2.5 mm ²
Conductor cross section AWG	24 ... 14
Torque	0.5 Nm ... 0.6 Nm

Insulation characteristics

Rated insulation voltage	500 V
Rated surge voltage	6 kV
Overvoltage category	III
Degree of pollution	2
Designation	Insulation characteristics between the control input and control supply voltage, and auxiliary circuit to the main circuit
Insulation	Safe isolation (IEC 60947-1) at operating voltage ≤ 300 V AC
	Safe isolation (EN 50178) at operating voltage ≤ 300 V AC
	Basic isolation (IEC 60947-1) at operating voltage 300 ... 500 V AC
	Safe isolation (EN 50178) at operating voltage 300 ... 500 V AC
Designation	Isolation characteristics between the control input and control supply voltage to auxiliary circuit

Hybrid motor starter - ELR H51-IESSC-24DC500AC-9 - 2902745

Technical data

Insulation characteristics

Insulation	Safe isolation (IEC 60947-1) in the auxiliary circuit ≤ 300 V AC
	Safe isolation (EN 50178) in the auxiliary circuit ≤ 300 V AC

Standards and Regulations

Designation	Standards/regulations
Standards/regulations	IEC 60947-1
	EN 60947-4-2
	IEC 61508
	ISO 13849

Conformance/approvals

Designation	ATEX
Identification	# II (2) G [Ex e] [Ex d] [Ex px]
	# II (2) D [Ex t] [Ex p]
Certificate	PTB 07 ATEX 3145
Designation	UL approval
Certificate	NLDX.E228652
Designation	Safety Integrity Level (SIL, IEC 61508)
Identification	≤ 3
Additional text	Safe shutdown
Designation	Safety Integrity Level (SIL, IEC 61508)
Identification	2
Additional text	Motor protection
Designation	Performance Level (ISO 13849)
Identification	e
Additional text	Safe shutdown
Designation	Category (ISO 13849)
Identification	≤ 3
Additional text	Safe shutdown

UL data

SCCR	100 kA (500 V AC (fuse: 30 A class CC/30 A class J (high fault)))
	5 kA (500 V AC (fuse: 20 A RK5 (standard fault)))
FLA	6.5 A (500 V AC)
Group installation	20 A (class RK5, SCCR 5kA, #24 - 14 AWG max. solid and stranded)
	30 A (class CC or J, SCCR 100kA, #24 - 14 AWG max, solid and stranded)
Category code	NLDX / NRNT

Environmental Product Compliance

REACH SVHC	Lead 7439-92-1
China RoHS	Environmentally Friendly Use Period = 50

Hybrid motor starter - ELR H51-IESSC-24DC500AC-9 - 2902745

Technical data

Environmental Product Compliance

	For details about hazardous substances go to tab "Downloads", Category "Manufacturer's declaration"
--	---

Drawings

Block diagram

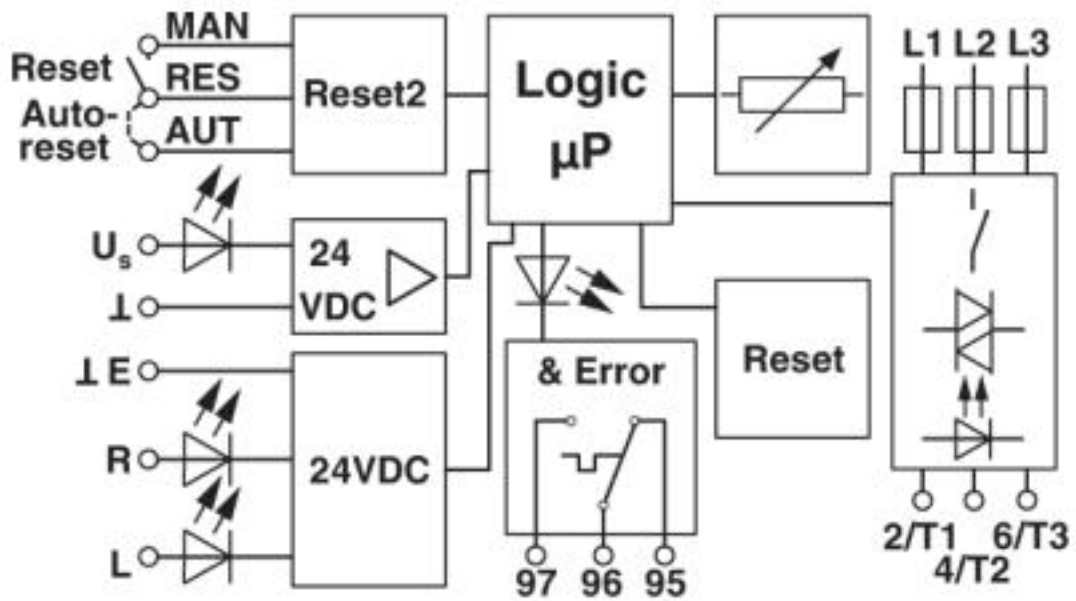

Articles in set

Fuse - FUSE-10X38-20A-GR - 2903384



Fuse, number: 10 Pcs., fuse type: Fuse (CC), nominal current: 20 A, tripping characteristic: super-fast blow (gR)

Approvals

Approvals

Approvals

IECEE CB Scheme / UL Listed / IECEE CB Scheme / cUL Listed / VDE Zeichengenehmigung / EAC / cULus Listed

Ex Approvals

ATEX

Hybrid motor starter - ELR H51-IESSC-24DC500AC-9 - 2902745

Approvals

Approval details

IECEE CB Scheme		http://www.iecee.org/	DE1-60642
UL Listed		http://database.ul.com/cgi-bin/XYV/template/LISEXT/1FRAME/index.htm	FILE E 228652
IECEE CB Scheme		http://www.iecee.org/	DE1-51298
cUL Listed		http://database.ul.com/cgi-bin/XYV/template/LISEXT/1FRAME/index.htm	FILE E 228652
VDE Zeichengenehmigung		http://www2.vde.com/de/Institut/Online-Service/VDE-gepruefteProdukte/Seiten/Online-Suche.aspx	40048531
EAC			RU C- DE.A*30.B.01082
cULus Listed			

Phoenix Contact 2019 © - all rights reserved
<http://www.phoenixcontact.com>

PHOENIX CONTACT GmbH & Co. KG
Flachsmarktstr. 8
32825 Blomberg
Germany
Tel. +49 5235 300
Fax +49 5235 3 41200
<http://www.phoenixcontact.com>