

PART NUMBER	REVISION	DESCRIPTION	FEED TYPE
2150095-2	C	FINE CRIMP HEIGHT ADJUST	PNEUMATIC
7-2150095-2	C	PNEUMATIC AND CRIMP TOOLING KIT	PNEUMATIC
7-2150095-7	A	CRIMP TOOLING KIT	-

ATLANTIC VERSION TERMINATOR INTERFACE ADAPTER

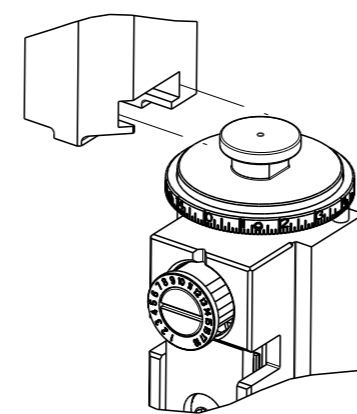

APPLICATOR DATA		
CRIMP	SIZE	TYPE
WIRE	2.03 mm [.080]	F
INSUL	2.79 mm [.110]	OV
APPLICATOR INSTRUCTIONS 408-35043		

TERMINAL DATA: TE TERMINAL TE CRIMP SPECIFICATION			
TERMINAL NAME: FASTIN-FASTON CONNECTOR			
WIRE STRIP LENGTH		INSULATION DIAMETER RANGE	
4.80-5.60 mm [.189-.220 IN]		∅1.40-2.30 mm [.055-.091 IN]	
TERMINAL APPLICATION SPECIFICATION	114-3118		
TERMINALS APPLIED			
TE TERMINAL	TE TERMINAL	TE TERMINAL	TE TERMINAL
160859-1	160859-3	160859-5	
160859-2	160859-4	160859-6	

WIRE SIZE	CRIMP HEIGHT mm [INCH]	CRIMP HEIGHT REFERENCE SETTING
1.00mm2	1.56 +/- 0.05 [.061 +/- .002]	7.3
0.75mm2	1.47 +/- 0.05 [.058 +/- .002]	8.3
0.50mm2	1.38 +/- 0.05 [.054 +/- .002]	9.4

- RECOMMENDED SPARE PARTS
  - REFER TO SUPPLIED INSTRUCTION SHEET FOR CLEANING, LUBRICATION AND STORAGE OF APPLICATOR.
  - APPLY PART NUMBER 2-23419-6 LOCTITE TO THREADS OF ITEM 242.
  - CRIMP HEIGHT REFERENCE SETTING WAS THE SETTING USED WHEN THE APPLICATOR WAS QUALIFIED AT THE FACTORY. ADJUSTMENT MAY BE NECESSARY WHEN RUNNING APPLICATOR IN THE FIELD.
  - TERMINAL PITCH NOT COMPATIBLE WITH MECHANICAL FEED.
6. UNLESS SPECIFIED OTHERWISE TORQUE VALUES SHALL BE USED PER DOCUMENT, 101-35000.

**\*WARNING**  
ON INSTALLATION, SET WIRE DISC TO CRIMP HEIGHT REFERENCE SETTING FOR LARGEST WIRE SIZE. CRIMP HEIGHT REFERENCE SETTINGS GREATER THAN THE VALUE SHOWN MAY CAUSE DAMAGE TO THE CRIMP TOOLING. REFER TO THE INSTRUCTION SHEET FOR PROPER SETUP AND ADJUSTMENTS.

LOC	DIST	REVISIONS					
A	66	#	LY#	DESCRIPTION	DATE	OWN	APVD
		2		UPDATE	12MAR2013	YY	UG
		A		RELEASED	23APR2013	YY	UG
		B		ECR-18-014836	18SEP2018	TB	TE
		C		ECR-19-008970	11JUN2019	LG	TE

-	1	1	2119641-1	FEED CAM, AIR FEED	248	
-	1	1	2119082-9	CAM, SNAIL, INSULATION ADJUSTMENT	244	
-	1	1	2079764-1	WASHER, WAVE SPRING, CREST-TO-CREST	243	
-	1	1	2119083-1	RETAINER, INSULATION DIAL	242	
-	1	1	2844940-4	AIR FEED MODULE	238	
-	1	1	1-18028-0	WASHER, FLAT, REG M8	192	
-	REF	REF	994970-2	COUNTER, MAGNETIC	164	
-	1	1	455888-4	SPACER, CRIMPER	82	
-	1	1	2119791-9	DEPRESSOR, WIRE	73	
-	1	1	1803607-4	DOCUMENTATION PACKAGE	71	
-	2	2	2-18032-2	SCR, SET, FLT PNT, M3 X 10.0	70	
-	1	1	2119740-1	TAG, IDENTIFICATION	67	
-	2	2	2168078-1	SCREW, DRIVE, RH, RoHS, 2 x .188	66	
-	1	1	2168083-2	SCR, SKT HD CAP, RoHS, M4 X 8.0	60	
-	1	1	5-18022-5	SCR, HEX HD CAP, M4 X 6.0	59	
-	4	4	2168400-4	SHCS, LOW HEAD, RoHS, M4 X 8	57	
-	2	2	2168083-9	SCR, SKT HD CAP, RoHS, M4 X 20	56	
-	2	2	5018030-1	NUT, HEX, REG, RoHS, M3	54	
-	2	2	986965-8	NUT, LOCK, HEX, TORQUE (M4)	53	
-	1	1	2063961-1	FEED FINGER	51	
-	1	1	18023-9	SCR, SKT HD CAP M4 X 6.0	49	
-	1	1	2119655-5	APPLICATOR BASIC ASSEMBLY, EF	46	
-	1	1	1803517-1	RAM ASSEMBLY, EF ATLANTIC	44	
-	1	1	1803602-1	SCR, BHSC, RoHS (M8 X 25)	41	
-	8	8	1-18028-2	WASHER, FLAT, REG M4	33	
-	2	2	2168083-9	SCR, SKT HD CAP, RoHS, M4 X 20	31	
-	2	2	2168083-2	SCR, SKT HD CAP, RoHS, M4 X 8.0	29	
-	1	1	240639-1	STRIPPER (MACHINING)	27	
-	2	2	1-2168083-5	SCR, SKT HD CAP, RoHS, M4 X 30	25	
-	1	1	1-1752371-2	PLATE, STRIP GUIDE	24	
-	2	2	2-22281-3	SPRING, COMPRESSION	22	
-	1	1	1803292-4	DRAG	20	
-	1	1	1-1901696-8	STRIP GUIDE, REAR	19	
-	1	1	1-1901695-8	STRIP GUIDE, FRONT	18	
-	4	4	1-2079383-1	SCR, BHSC, RoHS (M6 X 12)	17	
-	1	1	2-240641-6	SPACER	16	
-	1	1	240644-5	PLATE, REAR SHEAR	11	
-	1	1	5-690482-8	PLATE, FRONT SHEAR	9	
-	1	2	1-1333216-0	ANVIL, COMBINATION	8	
-	1	1	1-2217206-0	BLADE, SLUG	7	
-	-	-	-	-	6	
-	1	1	3-240641-7	SPACER	5	
-	1	1	238011-2	BLOCK, CRIMPER SPACER	4	
-	1	2	1633963-1	CRIMPER, INSULATION OVERLAP PREMIUM	3	
-	1	1	455888-5	SPACER, CRIMPER	2	
-	1	2	1-456405-3	CRIMPER, WIRE PREMIUM	1	
-	77	72	2	PART NO	DESCRIPTION	ITEM NO

ATLANTIC VERSION  
Shown on sheets 1 of 4 & 2 of 4  
(Pacific version shown on sheets 3 of 4 & 4 of 4)

DIMENSIONS:		TOLERANCES UNLESS OTHERWISE SPECIFIED:		DWN Y. YIN 12MAR2013		TE Connectivity	
mm		0 PLC ±	1 PLC ±	CHK G. BAILEY 12MAR2013	Harrisburg, PA 17105-3608		Ocean End Feed Applicator
		2 PLC ±	3 PLC ±	APVD U. GUO 12MAR2013	NAME		
MATERIAL		4 PLC ±	ANGLES FINISH	PRODUCT SPEC		SIZE CAGE CODE DRAWING NO RESTRICTED TO	
-		-		APPLICATION SPEC		A1 00779 C=2150095	
-		-		WEIGHT		Customer Accessible Production Drawing SCALE 1:1 SHEET 1 OF 4 REV C	

LOC	DIST	REVISIONS			
		REV	DATE	OWN	APVD
A	66	-	SEE SHEET 1	-	-

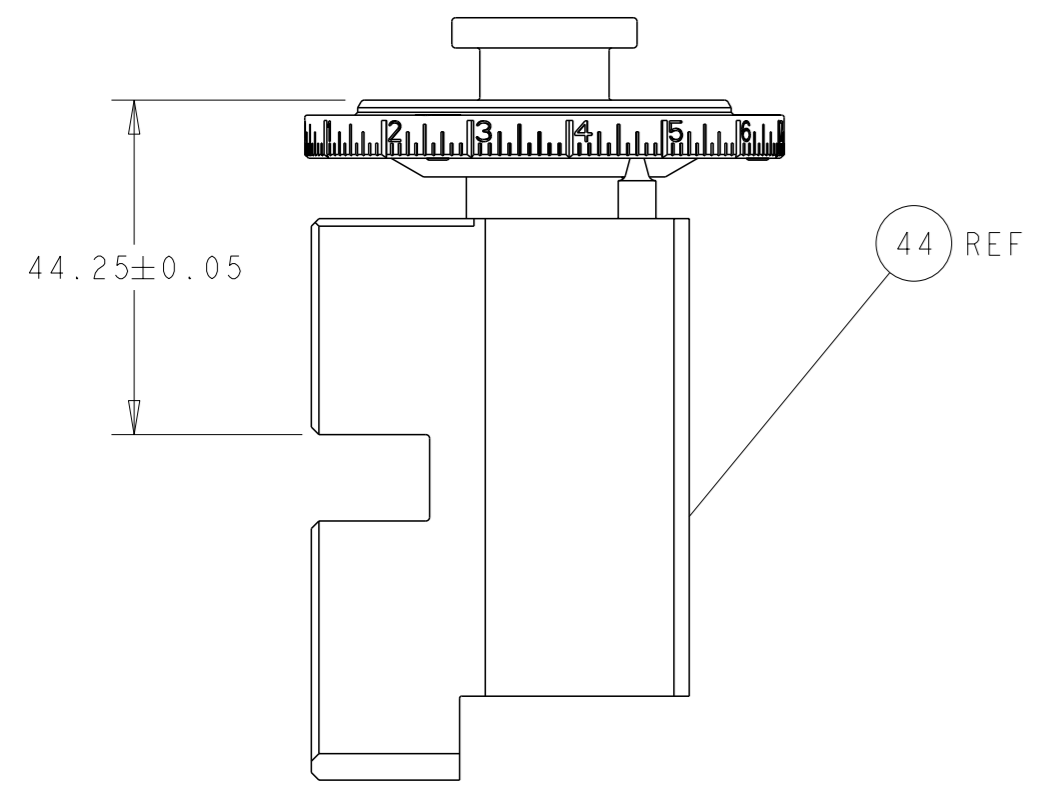

RAM SET-UP

FEED TYPE

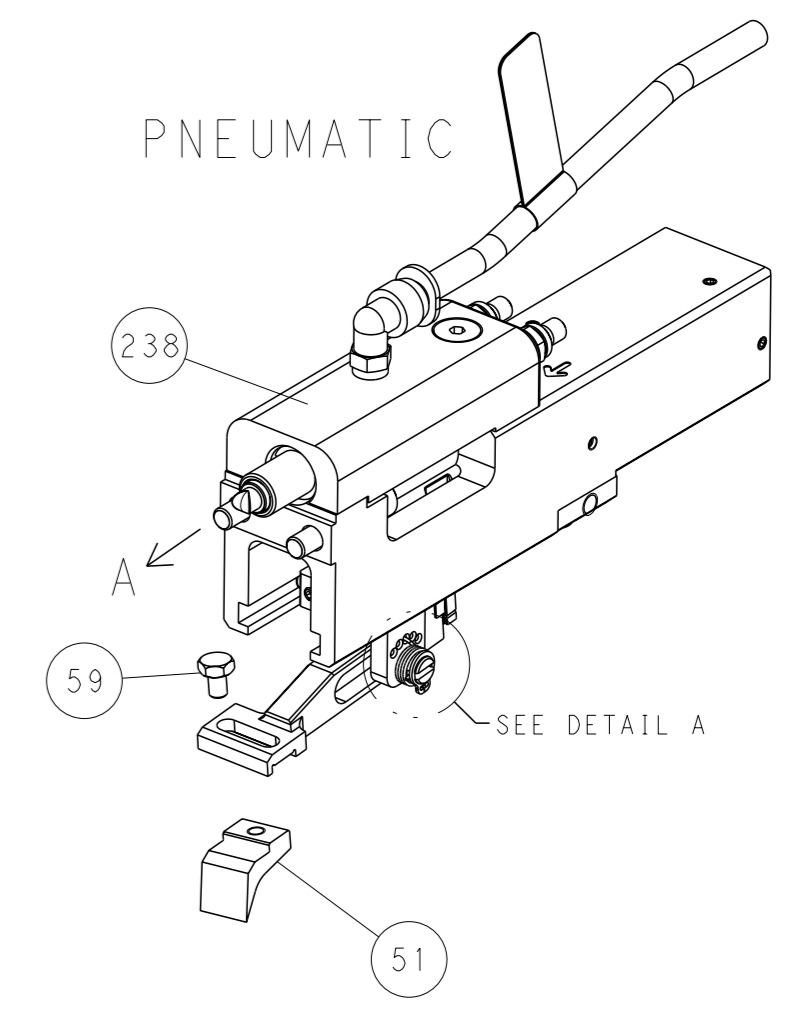

FEED SPRING SETTING POSITION

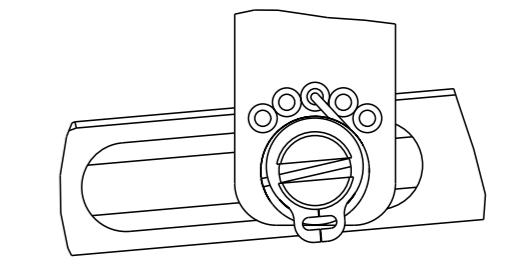

DETAIL A

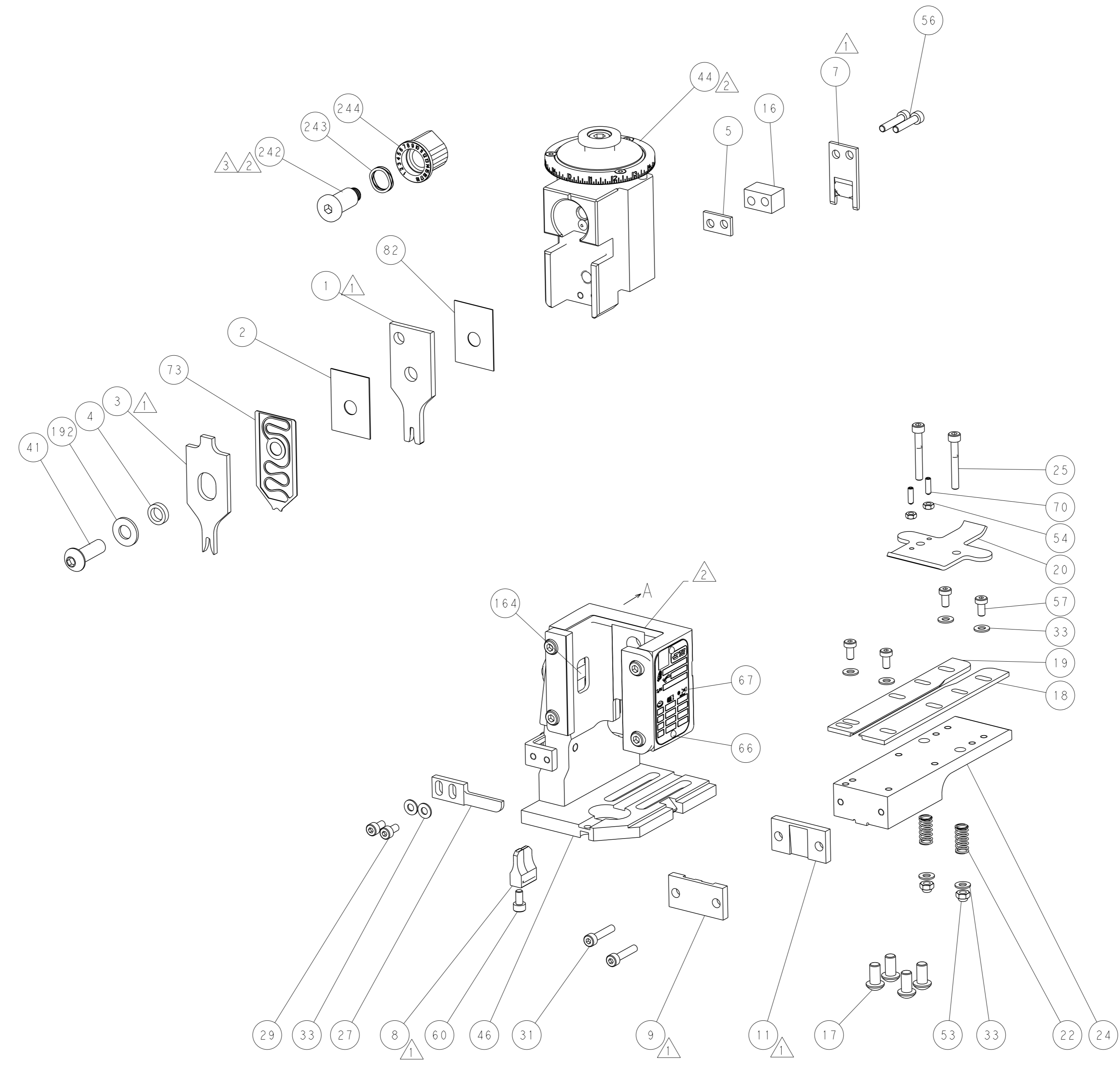

CAM POSITION

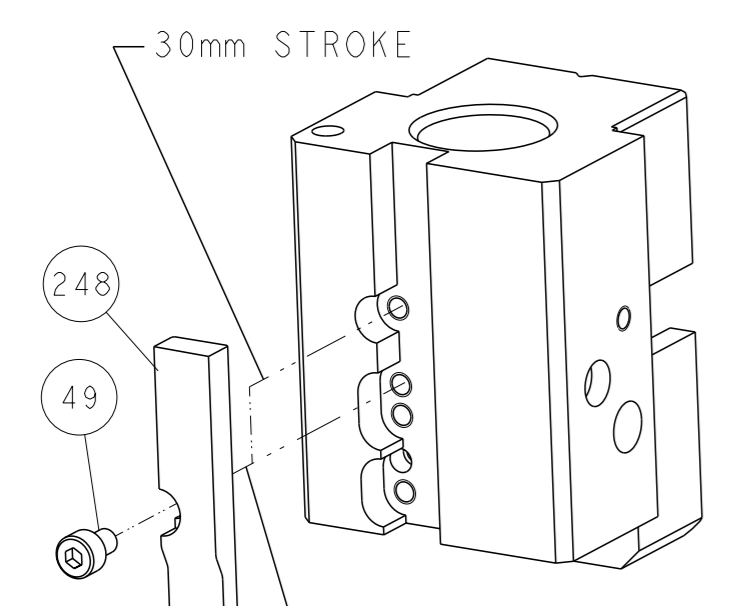

AIR FEED

ATLANTIC VERSION  
 Shown on sheets 1 of 4 & 2 of 4  
 (Pacific version shown on sheets 3 of 4 & 4 of 4)

<small>THIS DRAWING IS A CONTROLLED DOCUMENT FROM TYCO ELECTRONICS CORPORATION. IT IS SUBJECT TO CHANGE AND TO CONTROLING ENGINEERING DISCRETION. SHOULD BE CONTACTED FOR THE LATEST REVISION.</small>		DWN Y. YIN 12MAR2013 CHK G. BAILEY 12MAR2013 APVD U. GUO 12MAR2013	NAME Ocean End Feed Applicator
DIMENSIONS: mm TOLERANCES UNLESS OTHERWISE SPECIFIED: 0 PLC ± 1 PLC ± 2 PLC ± 3 PLC ± 4 PLC ± ANGLES FINISH ±	TOLERANCES UNLESS OTHERWISE SPECIFIED: 0 PLC ± 1 PLC ± 2 PLC ± 3 PLC ± 4 PLC ± ANGLES FINISH ±	SIZE CAGE CODE DRAWING NO A1 00779 C=2150095	RESTRICTED TO -
MATERIAL: -		WEIGHT: -	SCALE: 1:1 SHEET 2 OF 4 REV C

8	7	6	5	4	3	2	1
THIS DRAWING IS UNPUBLISHED.		RELEASED FOR PUBLICATION		20			
COPYRIGHT 20		BY TYCO ELECTRONICS CORPORATION. ALL RIGHTS RESERVED.					
PART NUMBER	REVISION	DESCRIPTION	FEED TYPE				
2-2150095-2	C	FINE CRIMP HEIGHT ADJUST	PNEUMATIC				
7-2150095-7	A	CRIMP TOOLING KIT	-				

PACIFIC VERSION TERMINATOR  
INTERFACE ADAPTER

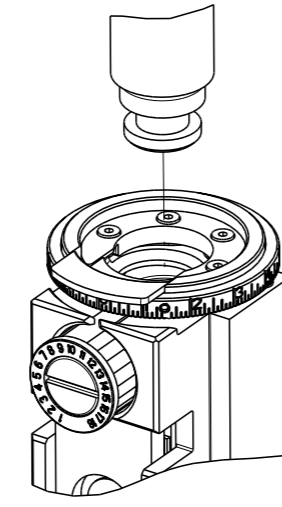

APPLICATOR DATA		
CRIMP	SIZE	TYPE
WIRE	2.03 mm [.080]	F
INSUL	2.79 mm [.110]	OV
APPLICATOR INSTRUCTIONS 408-35043		

TERMINAL DATA: TE TERMINAL		TE CRIMP SPECIFICATION	
TERMINAL NAME: FASTIN-FASTON CONNECTOR			
WIRE STRIP LENGTH 4.80-5.60 mm [1.89-.220 IN]		INSULATION DIAMETER RANGE Ø1.40-2.30 mm [1.055-.091 IN]	
TERMINAL APPLICATION SPECIFICATION	114-3118	-	-
TERMINALS APPLIED 5			
TE TERMINAL	TE TERMINAL	TE TERMINAL	TE TERMINAL
160859-1	160859-3	160859-5	
160859-2	160859-4	160859-6	

WIRE SIZE	CRIMP HEIGHT mm [INCH]	CRIMP HEIGHT REFERENCE SETTING
1.00mm2	1.56+/-0.05 [1.061+/-0.002]	7.3
0.75mm2	1.47+/-0.05 [1.058+/-0.002]	8.3
0.50mm2	1.38+/-0.05 [1.054+/-0.002]	9.4

- RECOMMENDED SPARE PARTS
- REFER TO SUPPLIED INSTRUCTION SHEET FOR CLEANING, LUBRICATION AND STORAGE OF APPLICATOR.
- APPLY PART NUMBER 2-23419-6 LOCTITE TO THREADS OF ITEM 242.
- CRIMP HEIGHT REFERENCE SETTING WAS THE SETTING USED WHEN THE APPLICATOR WAS QUALIFIED AT THE FACTORY. ADJUSTMENT MAY BE NECESSARY WHEN RUNNING APPLICATOR IN THE FIELD.
- TERMINAL PITCH NOT COMPATIBLE WITH MECHANICAL FEED.
- UNLESS SPECIFIED OTHERWISE TORQUE VALUES SHALL BE USED PER DOCUMENT, 101-35000.

**\*WARNING**  
ON INSTALLATION, SET WIRE DISC TO CRIMP HEIGHT REFERENCE SETTING FOR LARGEST WIRE SIZE. CRIMP HEIGHT REFERENCE SETTINGS GREATER THAN THE VALUE SHOWN MAY CAUSE DAMAGE TO THE CRIMP TOOLING. REFER TO THE INSTRUCTION SHEET FOR PROPER SETUP AND ADJUSTMENTS.

LOC	DIST	REVISIONS					
A	66	P	LYR	DESCRIPTION	DATE	OWN	APVD
		-		SEE SHEET 1	-	-	-

-	1	2119082-9	CAM, SNAIL, INSULATION ADJUSTMENT	244
-	1	2079764-1	WASHER, WAVE SPRING, CREST-TO-CREST	243
-	1	2119083-1	RETAINER, INSULATION DIAL	242
-	1	2844940-4	AIR FEED MODULE	238
-	1	1-18028-0	WASHER, FLAT, REG M8	192
-	4	2079383-9	SCR, BHSC, RoHS (M6 X 20)	186
-	REF	994970-2	COUNTER, MAGNETIC	164
-	1	2119641-2	FEED CAM, AIR FEED	152
-	1	2168083-8	SCR, SKT HD CAP, RoHS, M4 X 16	144
-	1	2119655-6	APPLICATOR BASIC ASSEMBLY, EF	141
-	1	1803518-1	RAM ASSEMBLY, EF PACIFIC	140
-	1	455888-4	SPACER, CRIMPER	82
-	1	2119791-9	DEPRESSOR, WIRE	73
-	1	1803607-4	DOCUMENTATION PACKAGE	71
-	2	2-18032-2	SCR, SET, FLT PNT, M3 X 10.0	70
-	1	2119740-1	TAG, IDENTIFICATION	67
-	2	2168078-1	SCREW, DRIVE, RH, RoHS, 2 x .188	66
-	1	5-18022-5	SCR, HEX HD CAP, M4 X 6.0	59
-	4	2168400-4	SHCS, LOW HEAD, RoHS, M4 X 8	57
-	2	2168083-9	SCR, SKT HD CAP, RoHS, M4 X 20	56
-	2	5018030-1	NUT, HEX, REG, RoHS, M3	54
-	2	986965-8	NUT, LOCK, HEX, TORQUE (M4)	53
-	1	2063961-1	FEED FINGER	51
-	1	18023-9	SCR, SKT HD CAP M4 X 6.0	49
-	1	1803602-1	SCR, BHSC, RoHS (M8 X 25)	41
-	8	1-18028-2	WASHER, FLAT, REG M4	33
-	2	2168083-9	SCR, SKT HD CAP, RoHS, M4 X 20	31
-	2	2168083-2	SCR, SKT HD CAP, RoHS, M4 X 8.0	29
-	1	240639-1	STRIPPER (MACHINING)	27
-	2	1-2168083-5	SCR, SKT HD CAP, RoHS, M4 X 30	25
-	1	1-1752371-2	PLATE, STRIP GUIDE	24
-	2	2-22281-3	SPRING, COMPRESSION	22
-	1	1803292-4	DRAG	20
-	1	1-1901696-8	STRIP GUIDE, REAR	19
-	1	1-1901695-8	STRIP GUIDE, FRONT	18
-	1	2-240641-6	SPACER	16
-	1	240644-5	PLATE, REAR SHEAR	11
-	1	5-690482-8	PLATE, FRONT SHEAR	9
1	1	1-1333216-0	ANVIL, COMBINATION	8
-	1	1-2217206-0	BLADE, SLUG	7
-	-	-	-	6
-	1	3-240641-7	SPACER	5
-	1	238011-2	BLOCK, CRIMPER SPACER	4
1	1	1633963-1	CRIMPER, INSULATION OVERLAP PREMIUM	3
-	1	455888-5	SPACER, CRIMPER	2
1	1	1-456405-3	CRIMPER, WIRE PREMIUM	1
-	-	-77-22	PART NO	ITEM NO

PACIFIC VERSION  
Shown on sheets 3 of 4 & 4 of 4  
(Atlantic version shown on sheets 1 of 4 & 2 of 4)

DIMENSIONS: mm		TOLERANCES UNLESS OTHERWISE SPECIFIED:		DWG Y. YIN 12MAR2013		CHK G. BAILEY 12MAR2013		APVD U. GUO 12MAR2013		NAME	
0 PLC ±		1 PLC ±		2 PLC ±		3 PLC ±		4 PLC ±		SIZE CAGE CODE DRAWING NO	
ANGLES FINISH		MATERIAL		WEIGHT		SCALE		SHEET		REV	
						A1 00779 ©=2150095		3 of 4		C	

