

DWG NO:	0097-0983		
REVISIONS			
MOVED "D" LANCES DOWN .020" MS 07-13-00		02	
ECO-E2719 UPDATED DRAWING PER WHS DRAWING. FAK 02-05-02 EWS 02-05-02		03	
ECO# AZ111352 DG 4-01-11 .084 WAS .080, .048 WAS .050, .450 WAS .447, INSPECTION NOTE		04	

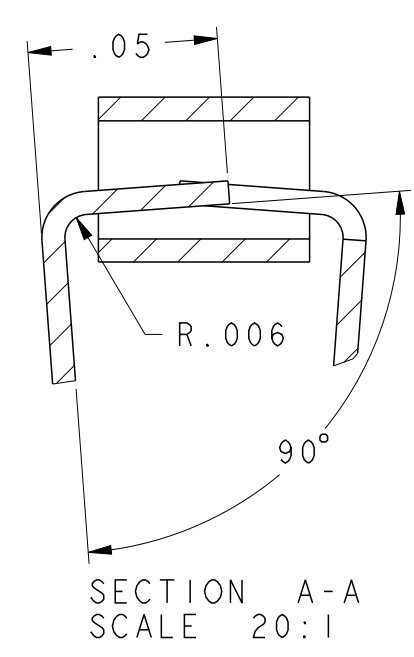
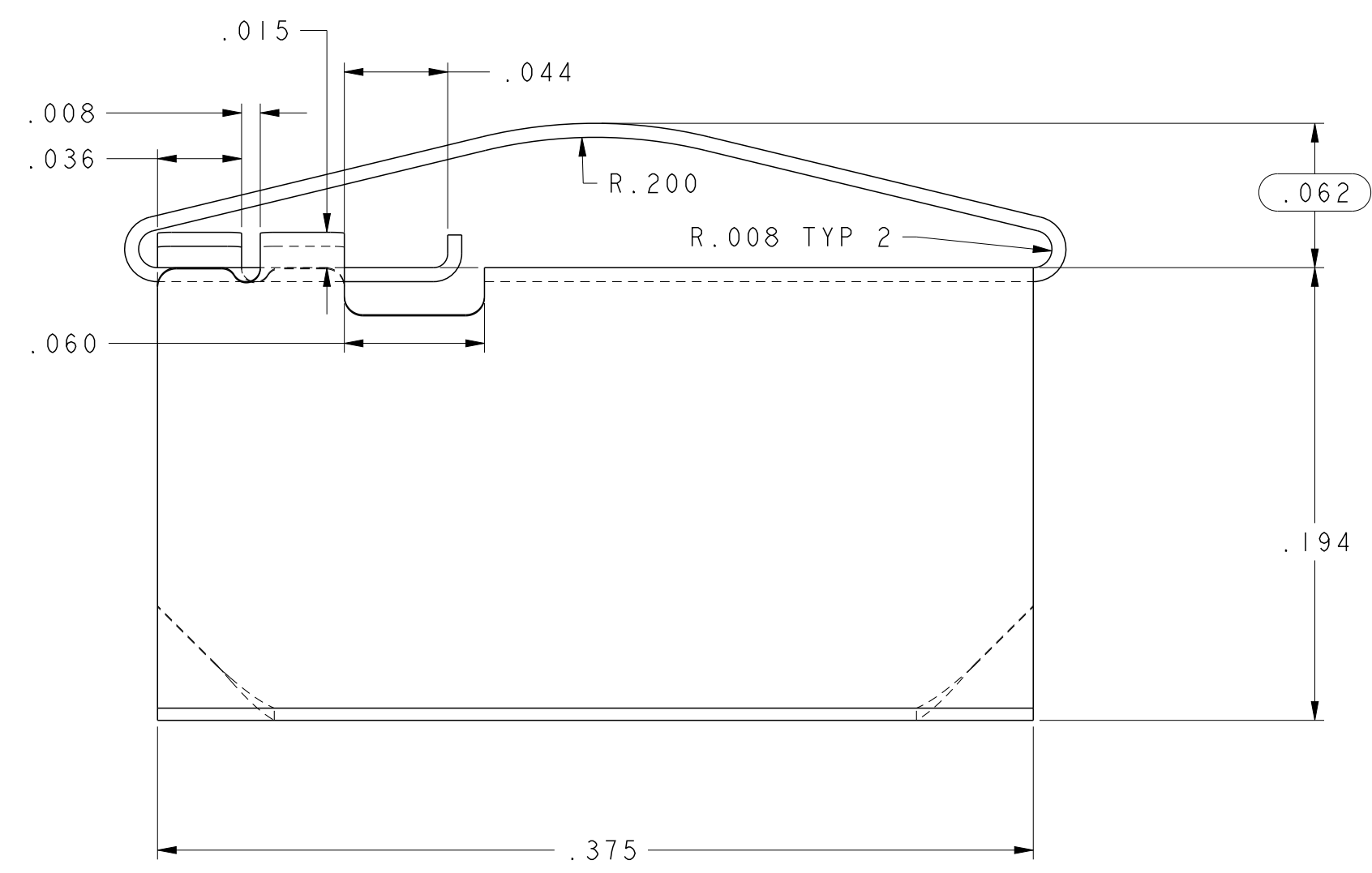
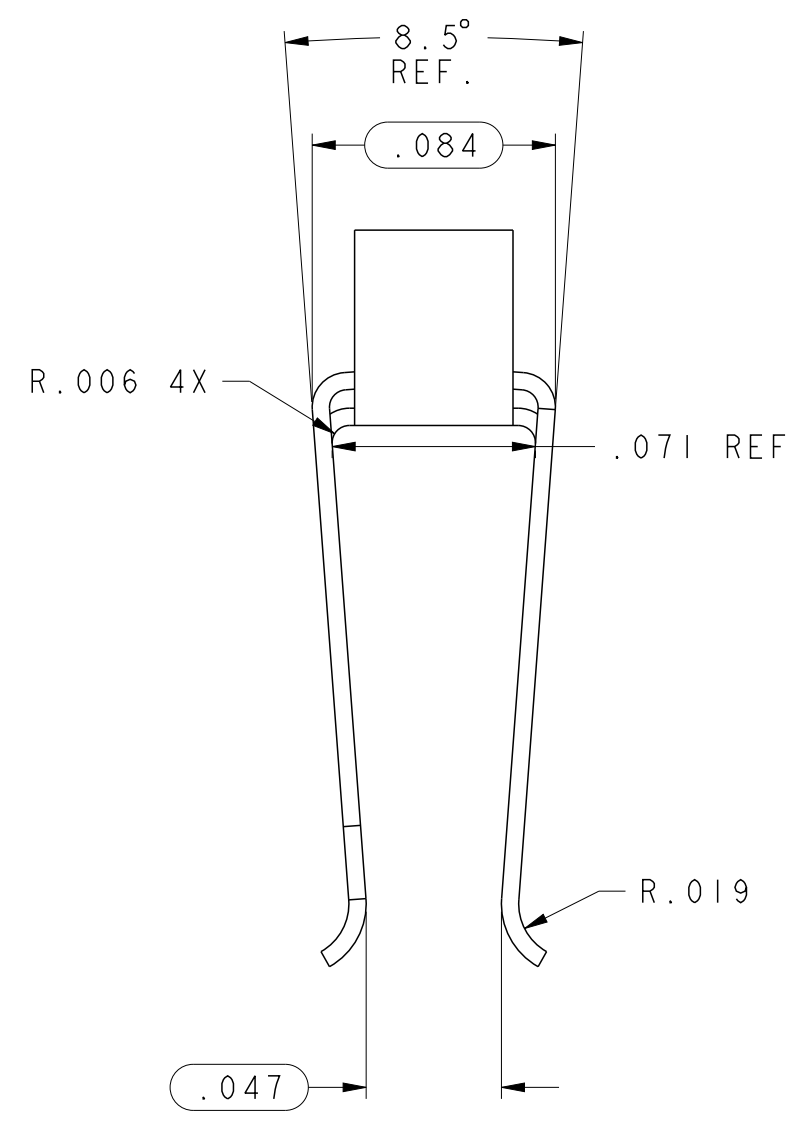
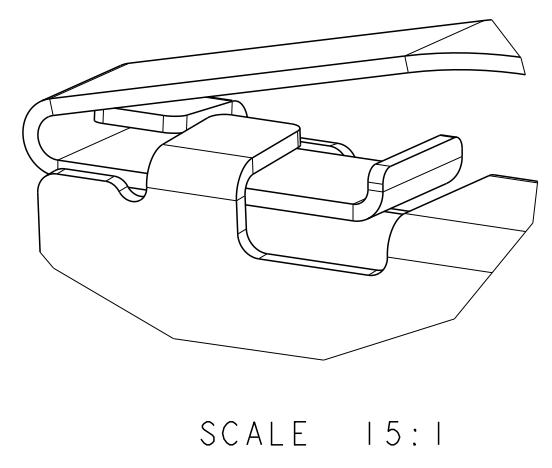
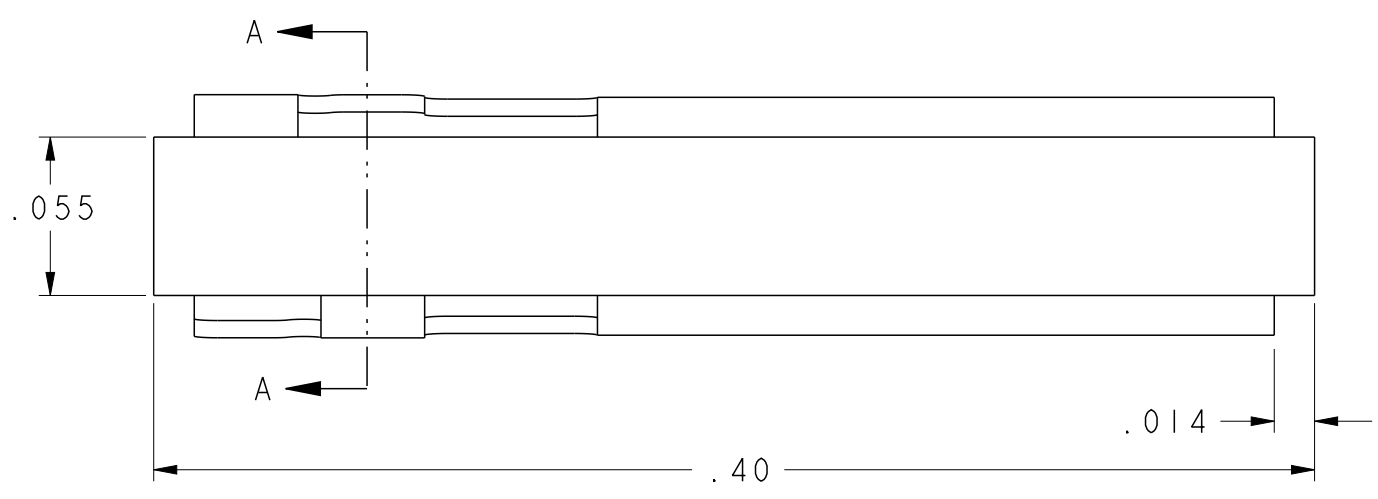
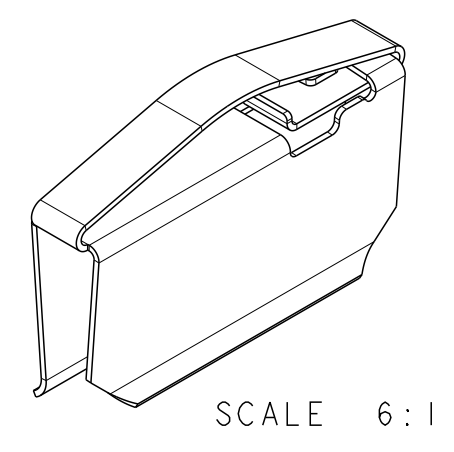
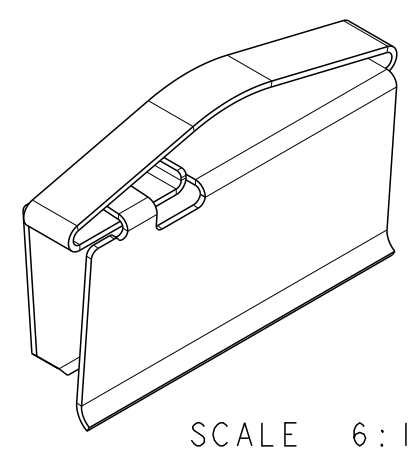
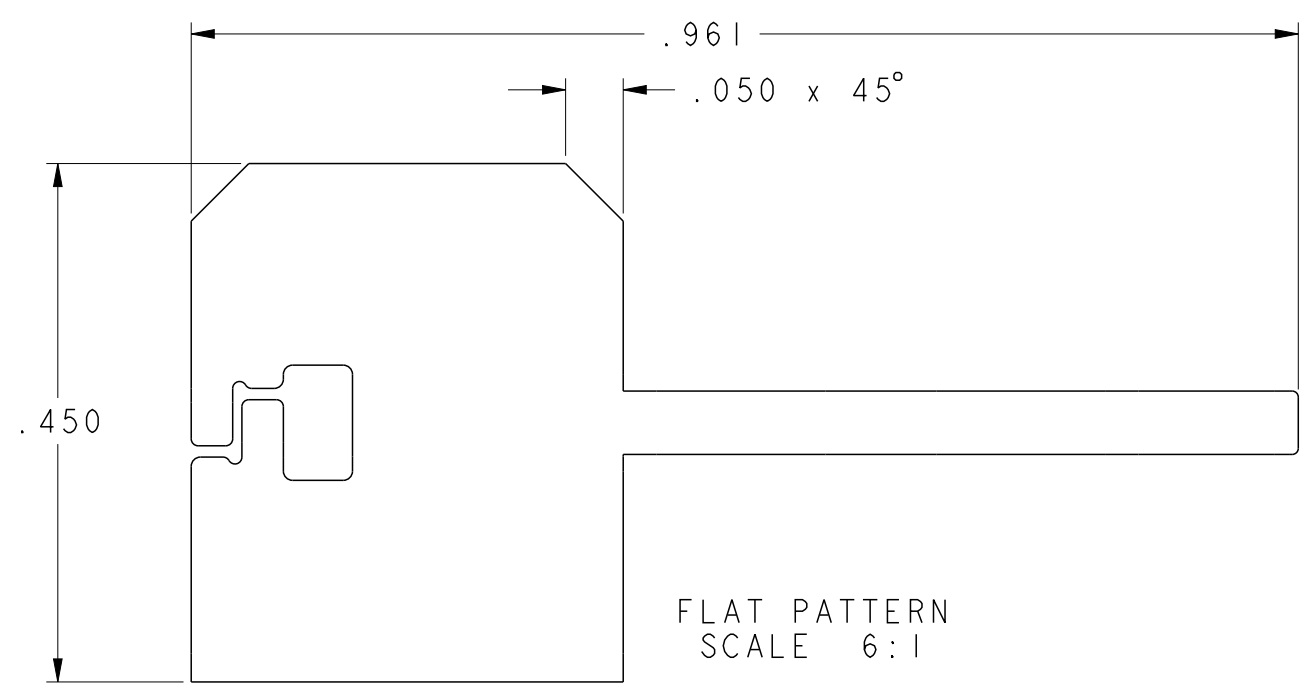

NOTE:  
CIRCLED DIMENSIONS ARE CRITICAL TO FUNCTION AND FIT.  
IN PROCESS INSPECTION IS REQUIRED FOR THESE DIMENSIONS.

MATERIAL: .006 ±.0002 x .?? ±.00? ALLOY 25 BECU 1/4H (TD01)	TOLERANCES NOT SHOWN	
	DECIMAL 2 PL'S ± .01	DECIMAL 3 PL'S ± .005
HEAT TREAT: TO DPH 353 MIN USING A 500 GRAM LOAD	ANGULAR ± 3°	THIRD ANGLE PROJECTION
THICKNESS AFTER: X X	UNITS: INCH [MM]	SCALE: 15:1
FINISH: BRIGHT TIN PER MIL-T-10727 .0002" ± .0001"	CAD MAINTAINED DRAWING. MANUAL CHANGES UNAUTHORIZED.	

	DRAWN BY: PVH	DATE: 06/22/99
	CHECKED: LP	DATE: 07/19/99
	APPROVED: PVH	DATE: 07/19/99
CARD GUIDE CLIP-ON		
REF. DWG. NO.	DWG. NO.	REV
	0097-0983	04
SHEET 1 OF 1		