



Molex MX150 Connectors 16 Way Hybrid Blade Connector Product Enhancements Customer Notification

May 16, 2013

Dear Molex Customer,

The purpose of this letter is to inform you of a product change to components associated with 16 way Hybrid Connector Assemblies:

33486-16**
33486-17**
33486-18**
33486-19**
33486-20**

The impacted components to the finished good assembly are the Grommet Cap and the Grommet Seal. The Grommet cap is molded in our Molex Lincoln, USA manufacturing plant and the Grommet Seal is purchased from our Seal supplier, both components are assembled in our Nogales, Mexico manufacturing plant. The reason for this change is in response to the growing desire to use 0.35mm² wire. As such, the Terminal hole geometry within the seal, along with the Terminal cavity geometry in the Grommet cap have been optimized to accept 0.35mm² wire while continuing to support larger wire up to 14AWG. This optimized hole geometry aids in proper terminal assembly to minimize risk of seal tearing.

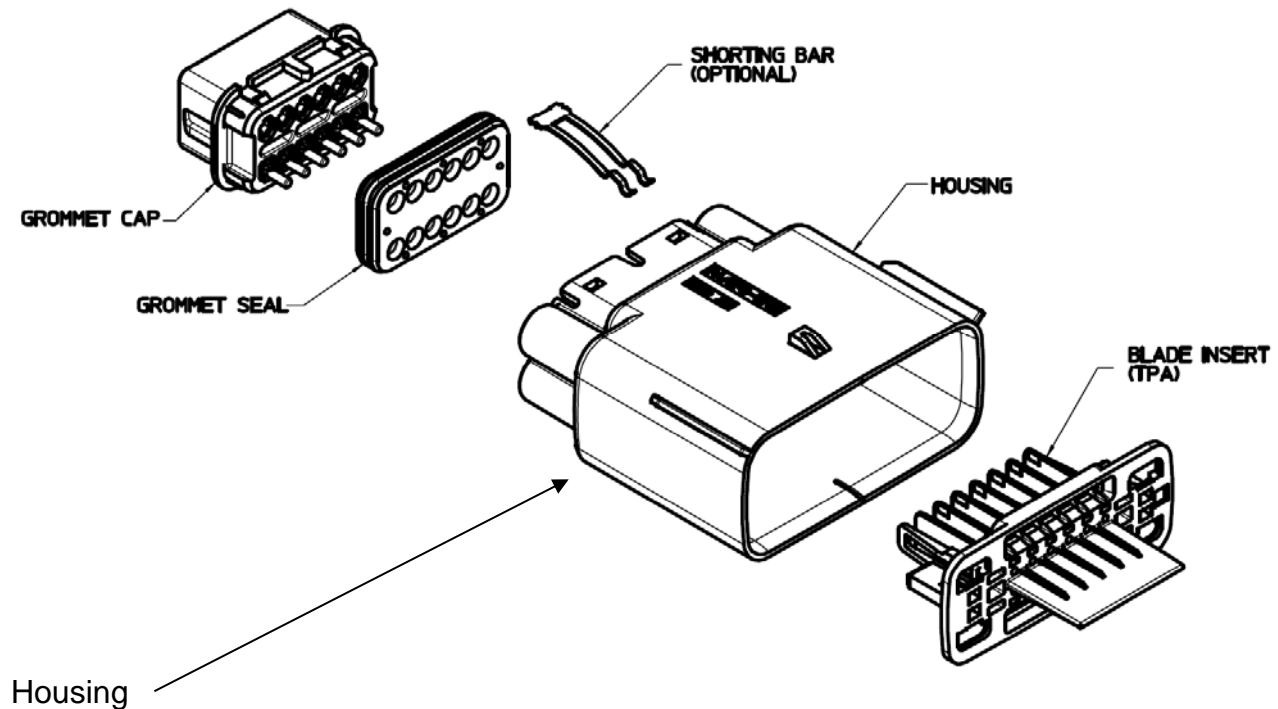

There are three noticeable visual differences!

- 1) Color of the Grommet Seal. The current color is blue, while the new version is a rust red.
- 2) Labeling of the manufacturing code to the Grommet Cap. The modified version has the manufacturing code molded on the front of the Cap as shown below.
- 3) Core outs on the face of the Grommet cap circled below.

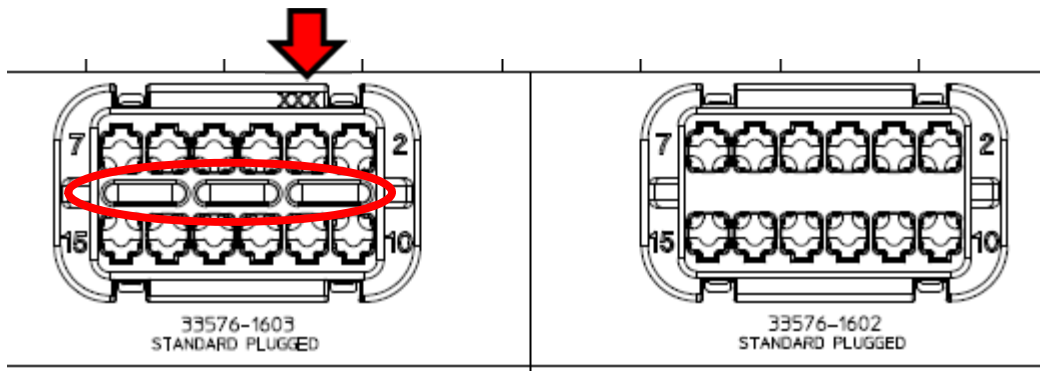

In addition to these visible differences, the part series number is changing from:

33486-**** to 34986-****

The suffix will remain the same!

For example, part number 33486-1601 will now be 34986-1601

These components are currently being validated. Following the appropriate inspection and validation requirements, parts containing these components should start to fill the pipeline as early as July 1st, 2013.

PPAP's can be supplied on an as needed basis and can be communicated through your local Molex Sales Representative.

Note: This letter was first issued on Jan 25th 2013. The content remains the same with the addition of the part number change.

AJ Pill
Global Product Manager
AJ.Pill@molex.com