

BALANCER MODEL:		WEIGHT RANGE		CABLE TRAVEL		OUTER COLOR
MATERIAL NUMBER	ENGINEERING NUMBER	LBS.	KG.	FT	M	
1301720889	30EAD-SS-FB	20.0 - 31.0	9.0 - 14.0	6.0	1.8	BLUE

DIMENSIONS ARE FOR REFERENCE ONLY.

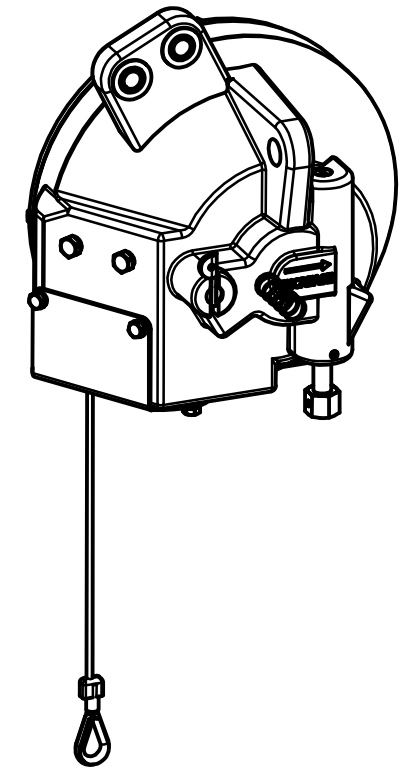

SECTION B-B

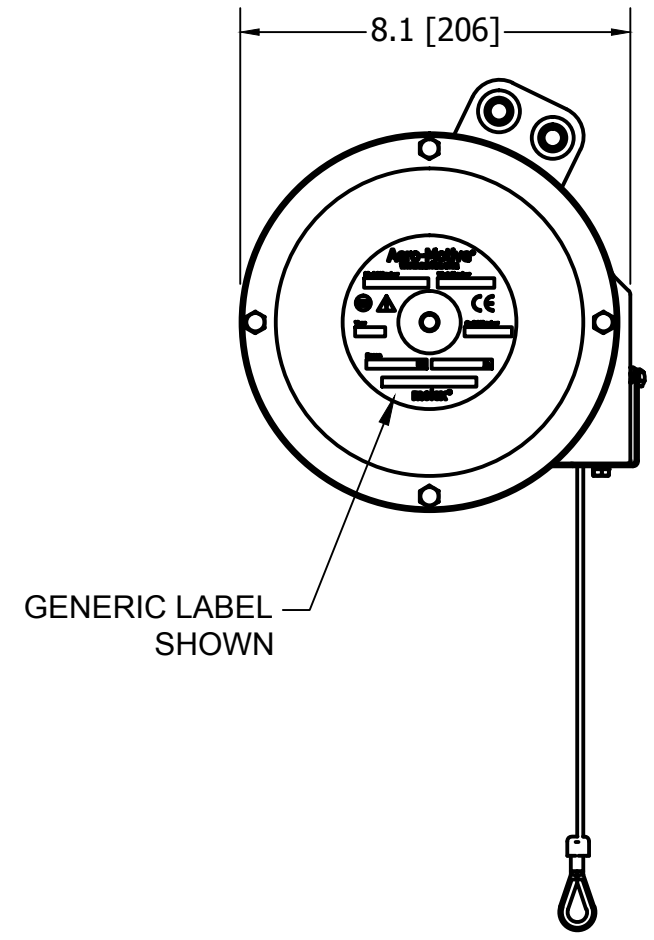
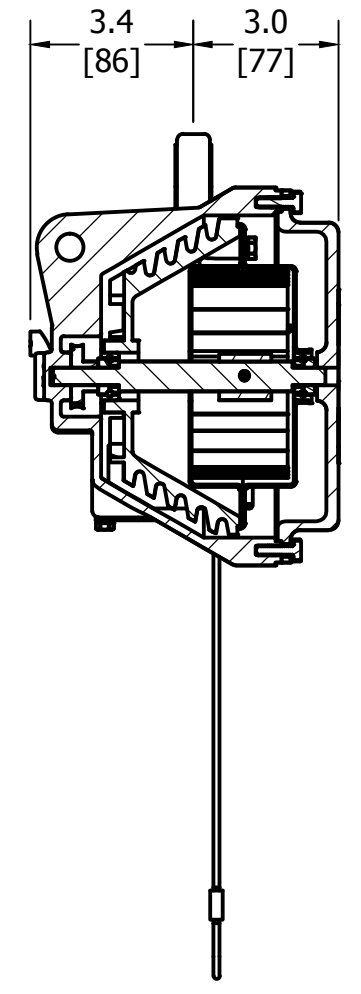
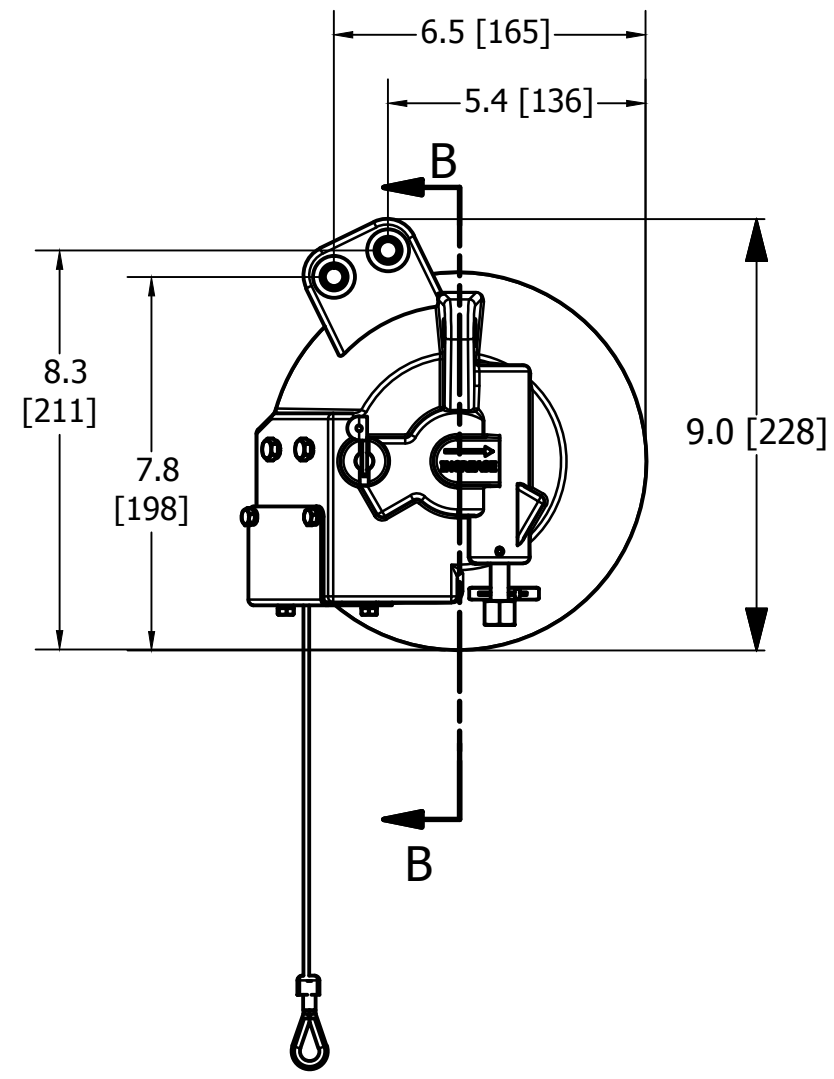
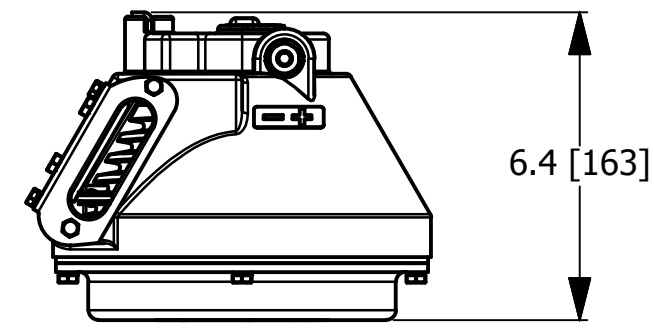

NEW RELEASE EC NO: IPG2017-0380 DRWN: VOU 2016/10/12 CHKD: BPATTERS 2016/10/28 APPR: JFMURPHY 2016/11/02	DESCRIPTION REV A	QUALITY SYMBOLS $\nabla=0$ $\triangle C=0$	GENERAL TOLERANCES (UNLESS SPECIFIED) mm INCH 4 PLACES $\pm$ --- $\pm$ --- 3 PLACES $\pm$ --- $\pm$ .005 2 PLACES $\pm$ 0.13 $\pm$ .010 1 PLACE $\pm$ 0.25 $\pm$ .020 ANGULAR $\pm$ 5°	DIMENSION STYLE INCH/MM DRAWN BY DATE VOU 2016/04/13 CHECKED BY DATE BPATTERS 2016/10/28 APPROVED BY DATE JFMURPHY 2016/11/02	SCALE NTS DESIGN UNITS INCH THIRD ANGLE PROJECTION	TITLE EA BALANCER SPECIAL SS CABLE W/ NO HOOK	MATERIAL NO. SEE CHART	DOCUMENT NO. SD-130172-008	SHEET NO. 1 OF 3	
		DRAFT WHERE APPLICABLE MUST REMAIN WITHIN DIMENSIONS			THIS DRAWING CONTAINS INFORMATION THAT IS PROPRIETARY TO MOLEX INCORPORATED AND SHOULD NOT BE USED WITHOUT WRITTEN PERMISSION		MOLEX INCORPORATED			

F

E

D

C

B

A

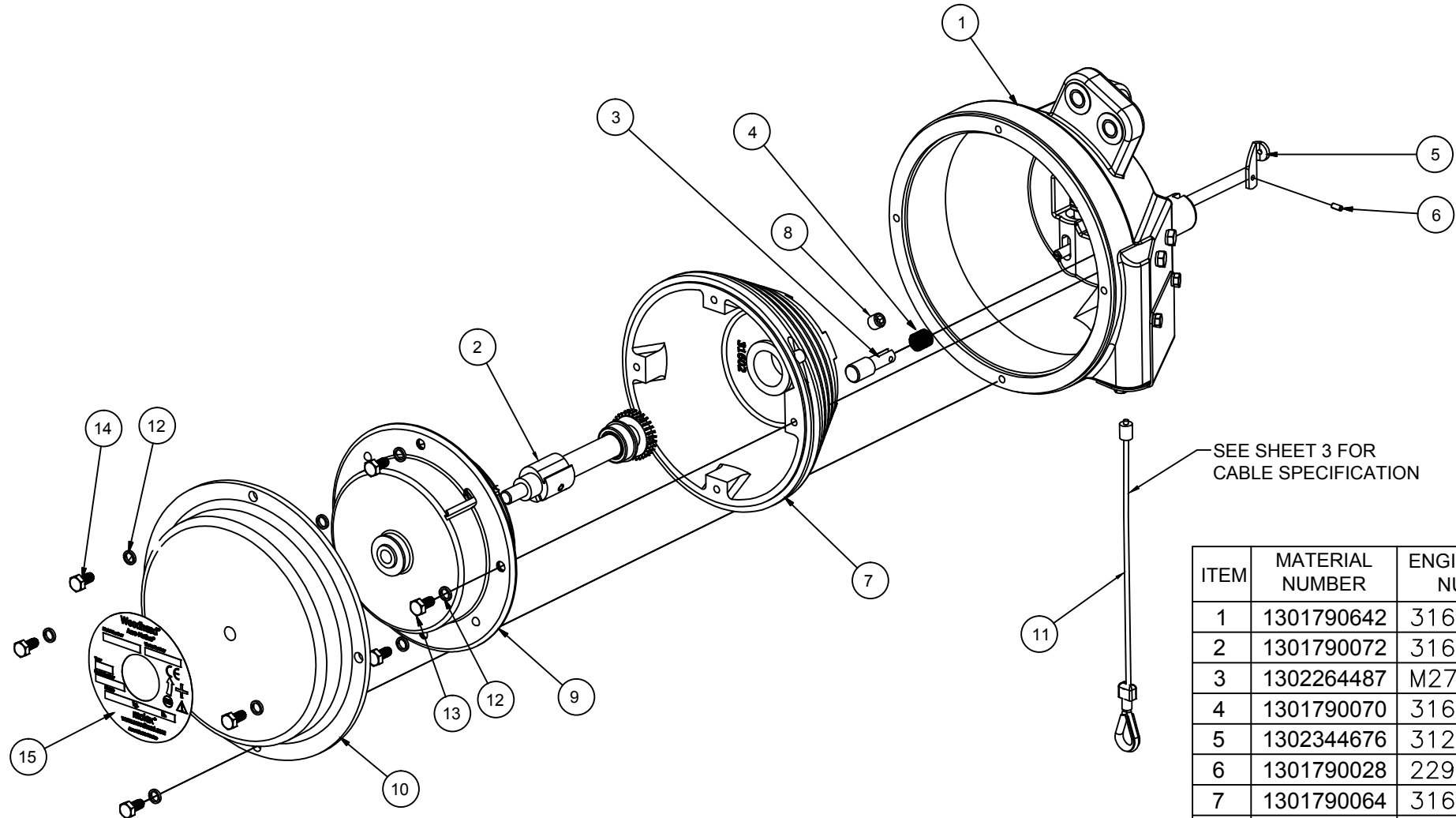

SEE SHEET 3 FOR CABLE SPECIFICATION

ITEM	MATERIAL NUMBER	ENGINEERING NUMBER	ITEM DESCRIPTION
1	1301790642	31656-1	ASSY MAIN HSNQ EA - POWDER BLUE
2	1301790072	31654	MAIN SHAFT ASSY FOR E BALANCER
3	1302264487	M27130042	SHAFT FOR E/EA MANUAL DRUM LOCK
4	1301790070	31643	SPRING FOR DRUM LOCK E/J/K/L
5	1302344676	31294	LOCK LEVER FOR E/J/K/L BALANCERS
6	1301790028	229-P-10	PIN ROLL 1/8 x 5/16 - BZP
7	1301790064	31602-1	CABLE DRUM MACHINED FOR E BALANCER
8	1301790114	827-P-5	1/8in NPTx 5/16in LG HEX SOCKET PLUG BZP
9	1301790077	31659-30	SPRING CASSETTE ASSEMBLY
10	1301792245	AG14660-1	EA CAST COVER POWDER - BLUE
11	1301792429	AG12855-SS	CABLE ASSY, STAINLESS STEEL, NO HOOK
12	1301790003	101-P-30	1/4-SPLIT LOCK WASHER[.26ID/.50D/.06W]
13	1301790150	AG12172	M6x1.0 - 12LG HEX HEAD SCREW
14	1301790534	AG12170	M6x1.0 - 20LG HEX HEAD SCREW
15	1302280761	M13060124	LABEL; ROUND

- NOTES:
- BALANCERS ARE 100% INSPECTED & PRE-TENSIONED TO MAX. WEIGHT.
  - HOUSINGS ARE MADE FROM ALUMINUM CASTING. THEY ARE POWDER COATED TO MEET HARSH INDUSTRIAL ENVIRONMENTS.
  - ALWAYS READ INSTRUCTIONS MANUAL BEFORE USING BALANCERS.
  - BALANCERS ARE NOT TO BE USED AS RETRACTORS THEIR MAIN PURPOSE BEING TO BALANCE A LOAD AND NOT TO RETRACT ONE.
  - OVERALL DIMENSIONS ARE FOR REFERENCE ONLY.

NEW RELEASE EC NO: IPG2017-0380 DRWN: VOU 2016/10/12 CHKD: BPATTERS 2016/10/28 APPR: JFMURPHY 2016/11/02	DESCRIPTION REV	QUALITY SYMBOLS	GENERAL TOLERANCES (UNLESS SPECIFIED)	DIMENSION STYLE	SCALE	DESIGN UNITS	THIRD ANGLE PROJECTION
		$\nabla=0$ $\sphericalangle=0$	mm    INCH 4 PLACES ±--- ±--- 3 PLACES ±--- ±.005 2 PLACES ±0.13 ±.010 1 PLACE ±0.25 ±.020 ANGULAR ±.5°	INCH/MM	NTS	INCH	EA BALANCER SPECIAL SS CABLE W/ NO HOOK ---- MOLEX INCORPORATED
		DRAFT WHERE APPLICABLE MUST REMAIN WITHIN DIMENSIONS	DRAWN BY    DATE VOU            2016/04/13 CHECKED BY    DATE BPATTERS      2016/10/28 APPROVED BY    DATE JFMURPHY      2016/11/02 MATERIAL NO.	TITLE SEE CHART	DOCUMENT NO. SD-130172-008	SHEET NO. 2 OF 3	
		A	B	THIS DRAWING CONTAINS INFORMATION THAT IS PROPRIETARY TO MOLEX INCORPORATED AND SHOULD NOT BE USED WITHOUT WRITTEN PERMISSION			

# CABLE SPECIFICATION

## (AG12855-SS)

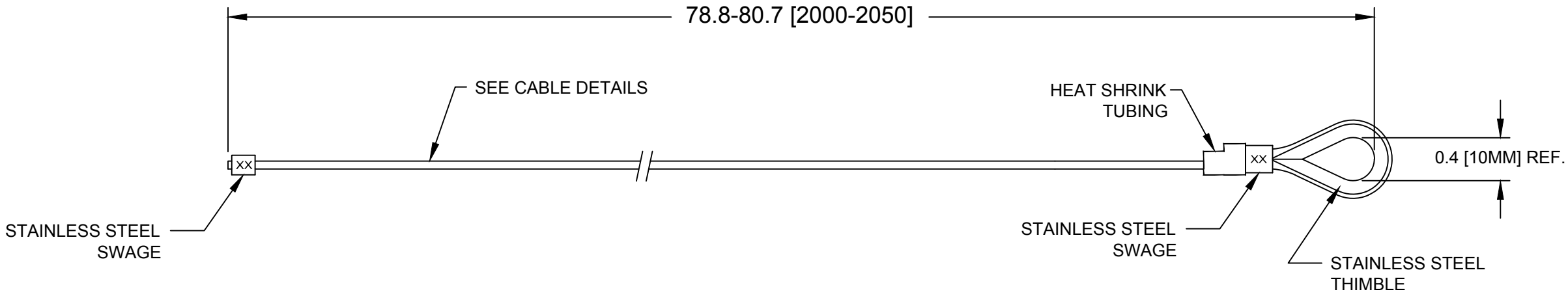

**CABLE DETAILS:**

**MATERIAL: 7X19 PREFORMED STAINLESS STEEL, 1/8 INCH [3MM] DIAMETER.**

NEW RELEASE EC NO: IPG2017-0380 DRWN: VOU 2016/10/12 CHKD: BPATTERS 2016/10/28 APPR: JFMURPHY 2016/11/02	DESCRIPTION REV	QUALITY SYMBOLS	GENERAL TOLERANCES (UNLESS SPECIFIED)		DIMENSION STYLE		SCALE	DESIGN UNITS	THIRD ANGLE PROJECTION		
		$\nabla=0$ $\sphericalangle=0$	mm	INCH	INCH/MM		NTS	INCH			
		4 PLACES ±--- ±--- 3 PLACES ±--- ±.005 2 PLACES ±0.13 ±.010 1 PLACE ±0.25 ±.020			DRAWN BY	DATE	TITLE				
		ANGULAR ±.5° DRAFT WHERE APPLICABLE MUST REMAIN WITHIN DIMENSIONS			VOU	2016/04/13	EA BALANCER SPECIAL SS CABLE W/ NO HOOK ---- MOLEX INCORPORATED				
			CHECKED BY	DATE	DOCUMENT NO.						
A			JFMURPHY	2016/11/02	SD-130172-008		3 OF 3				
			SIZE	THIS DRAWING CONTAINS INFORMATION THAT IS PROPRIETARY TO MOLEX INCORPORATED AND SHOULD NOT BE USED WITHOUT WRITTEN PERMISSION							
			B								