

Cable gland - HC-B-G-M25-EC-AL - 1411446

Please be informed that the data shown in this PDF Document is generated from our Online Catalog. Please find the complete data in the user's documentation. Our General Terms of Use for Downloads are valid (<http://phoenixcontact.com/download>)



EVO EMC cable gland with bayonet locking, B series, size M25, cable diameter: 11 - 16 mm



Key Commercial Data

Packing unit	1 pc
GTIN	 4 046356 932387
GTIN	4046356932387

Technical data

Dimensions

Wrench size, union nut	27 mm
External cable diameter	11 mm ... 16 mm

Ambient conditions

Degree of protection (IP)	IP66
	IP67
Degree of protection (NEMA)	4 (UL 50e)
	4X (UL 50e)
	12 (UL 50e)
Ambient temperature (operation)	-40 °C ... 125 °C (static)

General

Type of the screw connection	M25
No. of conductors	1
Material	Die-cast aluminum, corrosion-resistant
Housing material	Die-cast aluminum, corrosion resistant
Cable gland material	Aluminum

Cable gland - HC-B-G-M25-EC-AL - 1411446

Technical data

General

Material, pressure screw	Nickel-plated brass
Seal material	NBR
Cable seal material	NBR
Sealing material	NBR (O-ring)
Shielded	yes
Thread type on connection side	Bayonet B metal
Tightening torque, union nut	7.50 Nm
Color	silver

Environmental Product Compliance

REACH SVHC	Lead 7439-92-1
China RoHS	Environmentally Friendly Use Period = 50
	For details about hazardous substances go to tab "Downloads", Category "Manufacturer's declaration"

Drawings

Dimensional drawing

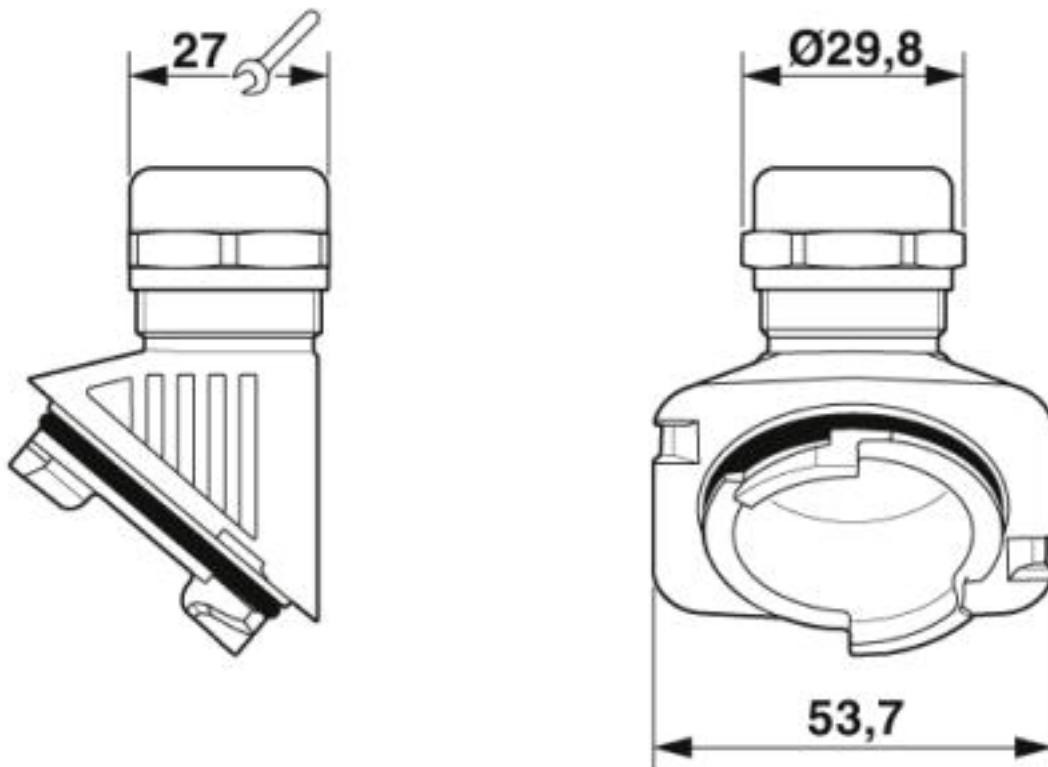

Dimensional drawing

Cable gland - HC-B-G-M25-EC-AL - 1411446

Approvals



Approvals

Approvals

UL Recognized / cUL Recognized / EAC / cULus Recognized

Ex Approvals

Approval details

UL Recognized		http://database.ul.com/cgi-bin/XYV/template/LISEXT/1FRAME/index.htm	E255026
cUL Recognized		http://database.ul.com/cgi-bin/XYV/template/LISEXT/1FRAME/index.htm	E255026
EAC			RU C- DE.AI30.B.01102
cULus Recognized			

Phoenix Contact 2019 © - all rights reserved
<http://www.phoenixcontact.com>

PHOENIX CONTACT GmbH & Co. KG
Flachsmarktstr. 8
32825 Blomberg
Germany
Tel. +49 5235 300
Fax +49 5235 3 41200
<http://www.phoenixcontact.com>