

4

3

2

1

THIS DRAWING IS UNPUBLISHED. RELEASED FOR PUBLICATION
 © COPYRIGHT - TE Connectivity Ltd. ALL RIGHTS RESERVED.

REVISIONS				
P	LTR	DESCRIPTION	DATE	APVD
2		DRAWING UPDATED	10JAN2020	DHC AS

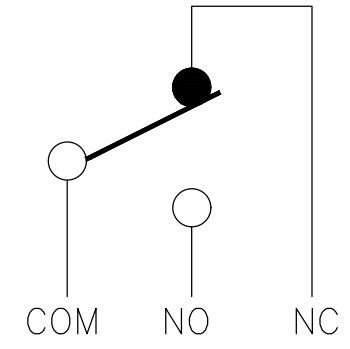
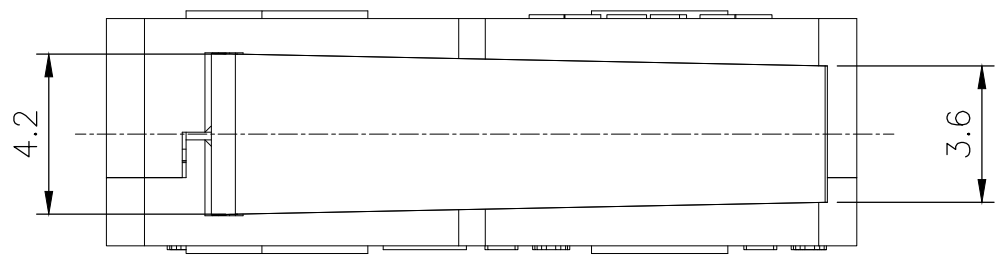

CIRCUIT DIAGRAM

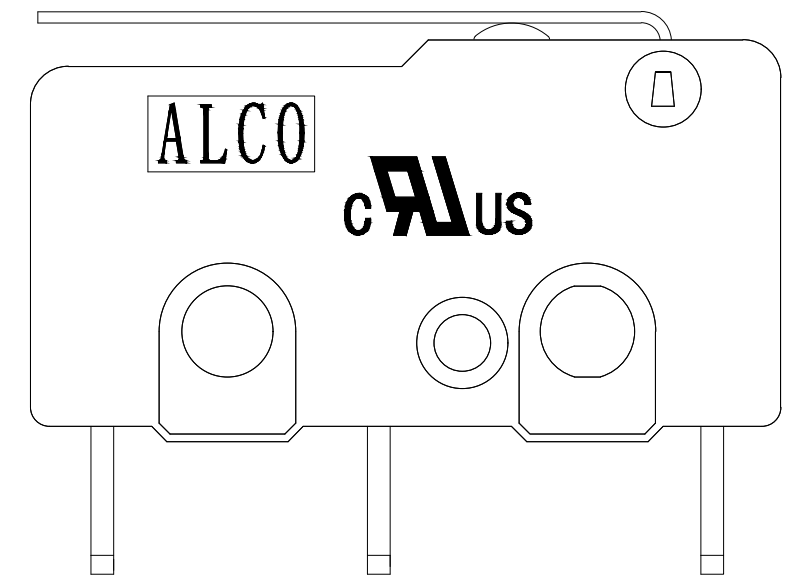
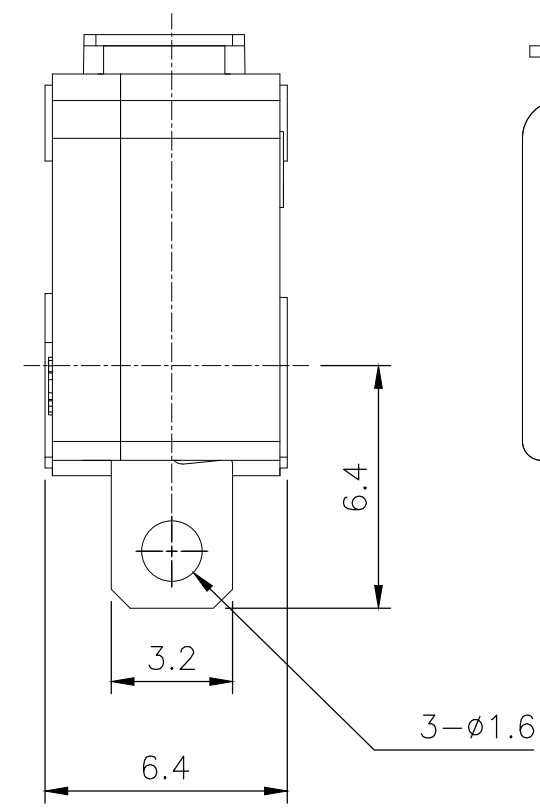
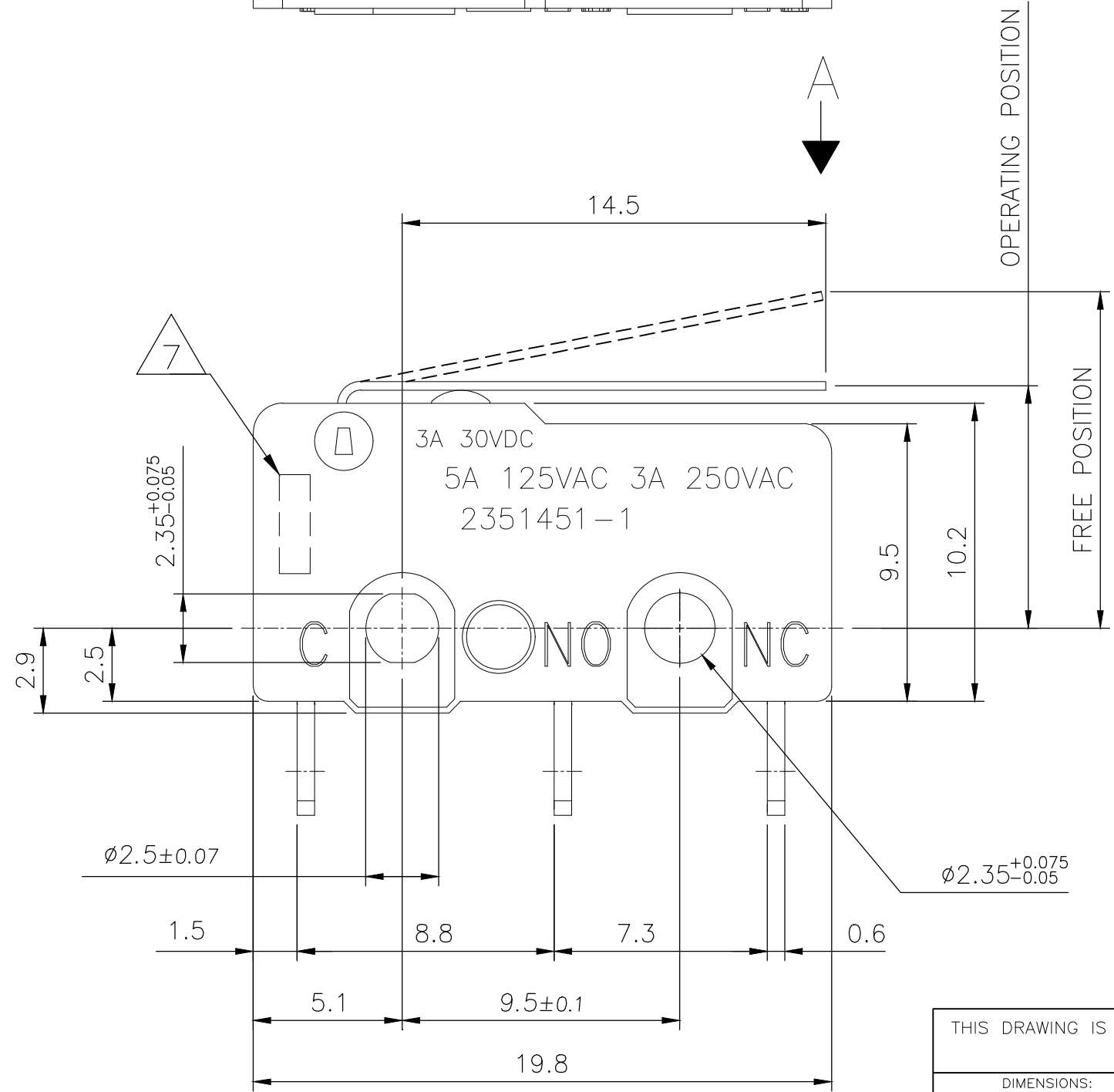

PRELIMINARY

THIS DRAWING IS A CONTROLLED DOCUMENT.		DWN GANESH_CM 09MAY2019	TE Connectivity Ltd.	
DIMENSIONS: mm 		CHK ALEXANDER_SHARPE 09MAY2019		
TOLERANCES UNLESS OTHERWISE SPECIFIED: 0 PLC ± - 1 PLC ± - 2 PLC ± 0.4 3 PLC ± - 4 PLC ± - ANGLES ± -		APVD ALEXANDER_SHARPE 09MAY2019	NAME	
MATERIAL -		FINISH -	SWITCH, SUBMINIATURE SNAP ACTION, HINGE LEVER, SOLDER TERMINAL	
		PRODUCT SPEC -	SIZE A3	CAGE CODE 00779
		APPLICATION SPEC -	DRAWING NO C-2351451	RESTRICTED TO -
		WEIGHT -	SCALE NTS	SHEET 1 OF 2
		CUSTOMER DRAWING	REV 2	

THIS DRAWING IS UNPUBLISHED. RELEASED FOR PUBLICATION
 © COPYRIGHT - TE Connectivity Ltd. ALL RIGHTS RESERVED.

REVISIONS					
P	LTR	DESCRIPTION	DATE	DWN	APVD
	-	SEE SHEET 1	-	-	-

NOTES:

- OPERATING CHARACTERISTICS ARE FOR OPERATION IN THE A DIRECTION 
- PACKAGING:
SWITCHES ARE BULK PACKAGED IN BAGS, 100 SWITCHES PER BAG, 10 BAGS PER BOX.
- COMPLIANCE:
THE CURRENT STATEMENT OF COMPLIANCE IS AVAILABLE AT TE.COM.
- MATERIAL AND FINISH:
LEVER: STAINLESS STEEL
BUTTON: THERMOPLASTIC, WHITE
COVER: THERMOPLASTIC, BLACK
SPRING PLATE: COPPER ALLOY
MOVING PLATE: COPPER ALLOY
CONTACTS: SILVER ALLOY
RIVET: ALUMINUM
TERMINAL: BRASS, SILVER PLATED
BASE: THERMOPLASTIC, BLACK
- SPECIFICATIONS:
CURRENT RATING: SEE TABLE
CONTACT RESISTANCE: 50mΩ MAXIMUM INITIAL AT FREE POSITION AND TOTAL TRAVEL POSITION
INSULATION RESISTANCE: 100MΩ MINIMUM @ 500 V DC FOR 1 MINUTE, INITIAL.
DIELECTRIC WITHSTANDING VOLTAGE, BETWEEN TERMINALS OF THE SAME POLARITY: 1000 V AC, 50 TO 60 HZ FOR 1 MINUTE
DIELECTRIC WITHSTANDING VOLTAGE, BETWEEN EACH TERMINAL AND GROUND: 1500 V AC, 50 TO 60 HZ FOR 1 MINUTE
DIELECTRIC WITHSTANDING VOLTAGE, BETWEEN EACH TERMINAL AND NON-CURRENT CARRYING METAL PART: 1500 V AC, 50 TO 60 HZ FOR 1 MINUTE
- SOLDER PROCESS:
MANUAL SOLDERING: 350°C, 3 SECONDS MAXIMUM, 30 TO 40 WATTS. PREVENT SOLDER AND FLUX CONTACTING THE SWITCH BODY.
DO NOT OPERATE THE SWITCH DURING THE FIRST MINUTE AFTER SOLDERING.
WAVE SOLDERING: 260°C, 5 SECONDS MAXIMUM. PREVENT SOLDER AND FLUX CONTACTING THE SWITCH BODY.
DO NOT OPERATE THE SWITCH DURING THE FIRST MINUTE AFTER SOLDERING.

 DATE CODE:
 ① ② ③ ④

①	DAY	01 TO 31
②	MONTH	1 TO 9, X, Y, Z (X=10, Y=11, Z=12)
③	YEAR	00 TO 99
④	OTHER	N/A

8. CERTIFICATION: 

SILVER	SPDT	10,000,000 CYCLES, MINIMUM	100,000 CYCLES, MINIMUM	-40 TO +85°C/85% RELATIVE HUMIDITY MAXIMUM	-40 TO +105°C/60% RELATIVE HUMIDITY MAXIMUM	0.8 MAXIMUM	1.20 MINIMUM	8.8±0.8	12.0 MAXIMUM	0.06N MINIMUM	0.49N MAXIMUM	5A, 125VAC 3A, 250VAC 3A, 30VDC	MOMENTARY	SOLDER	SAJ25YXHL0147SDTSEQ	2351451-1
CONTACT FINISH	CONTACT FORM	MECHANICAL LIFE	ELECTRICAL LIFE	STORAGE TEMPERATURE RANGE/HUMIDITY RANGE	OPERATING TEMPERATURE RANGE/HUMIDITY RANGE	MOVEMENT DIFFERENTIAL	OVERTRAVEL	OPERATING POSITION	FREE POSITION	RELEASE FORCE	OPERATING FORCE	RATING, RESISTIVE LOAD	CONTACT CONFIGURATION	TERMINAL TYPE	TE SMART PART NUMBER	PART NUMBER

PRELIMINARY

THIS DRAWING IS A CONTROLLED DOCUMENT.

DWN	GANESH_CM	09MAY2019
CHK	ALEXANDER_SHARPE	09MAY2019
APVD	ALEXANDER_SHARPE	09MAY2019
NAME	SWITCH, SUBMINIATURE SNAP ACTION, HINGE LEVER, SOLDER TERMINAL	
PRODUCT SPEC	-	
APPLICATION SPEC	-	
WEIGHT	-	-
CUSTOMER DRAWING	SCALE NTS	SHEET 2 OF 2
SIZE	A3	CAGE CODE 00779
DRAWING NO	G=2351451	
RESTRICTED TO	-	
REV	2	