

**ABSTRACT**

This user's guide describes the TPS23758 evaluation module (EVM). The TPS23758 evaluation module (TPS23758EVM-080) contains evaluation and reference circuitry for the TPS23758 device. The TPS23758 device is an IEEE 802.3at Type 1 compliant, powered-device (PD) controller and power supply controller optimized for primary side regulation flyback converter topologies. The TPS23758EVM-080 is targeted for a 5-V synchronous-rectified high efficiency 13-W PD solution.

Table of Contents

1 Introduction	2
2 Electrical Specifications	2
3 Description	3
4 Schematic	4
5 General Configuration and Description	5
6 TPS23758EVM-080 Performance Data	6
7 EVM Assembly Drawings and Layout Guidelines	12
8 Bill of Materials	16
9 Revision History	21

List of Figures

Figure 4-1. TPS23758EVM-080 Schematic.....	4
Figure 6-1. Startup Response When Connected to a PoE PSE (TPS23880).....	6
Figure 6-2. DCDC Startup.....	6
Figure 6-3. Transient Response from 100 mA to 1 A for a 48-V Input.....	7
Figure 6-4. Efficiency of the TPS23758EVM-080.....	8
Figure 6-5. TPS23758EVM-080 Load Regulation.....	9
Figure 6-6. DCDC Recovery from Output Short.....	9
Figure 6-7. SRF = 0 Ω	10
Figure 6-8. SRF = 100 Ω	10
Figure 6-9. SRR = 0 Ω	11
Figure 6-10. SRR = 10 Ω	11
Figure 7-1. Top-Side Component Placement.....	12
Figure 7-2. Layer 2 Routing.....	12
Figure 7-3. Layer 3 Routing.....	13
Figure 7-4. Bottom-Side Routing.....	13

List of Tables

Table 2-1. TPS23758EVM-080 Electrical and Performance Specifications at 25°C.....	2
Table 5-1. Connector Functionality.....	5
Table 5-2. Test Points.....	5
Table 8-1. TPS23758EVM-080 BOM.....	16

Trademarks

All trademarks are the property of their respective owners.

1 Introduction

The TPS23758EVM-080 allows reference circuitry evaluation of the TPS23758 device. It contains input and output power connectors and an array of onboard test points for circuit evaluation.

1.1 Features

- IEEE802.3at Type 1 compliant PoE PD
- Class 0 5-V and 2.3-A primary side regulated CCM flyback
- Advanced startup
- Programmable slew rate and frequency dithering for EMI reduction
- Primary-side adapter priority control

1.2 Applications

- IP cameras
- Access points
- Point-of-sale
- Barcode readers
- IP phones
- Wireless LAN- wireless access points

2 Electrical Specifications

Table 2-1. TPS23758EVM-080 Electrical and Performance Specifications at 25°C

PARAMETER	TEST CONDITIONS	MIN	TYP	MAX	UNIT
POWER INTERFACE					
Input voltage	Applied to the power pins of connectors J1	37		57	V
	Applied to the power pins of connectors J4		48		V
Input UVLO, POE input J1	Rising input voltage			36	V
	Falling input voltage	30			
Detection voltage	At device terminals	2.7		10.1	V
Classification voltage	At device terminals	14.5		20.5	V
Classification Current	Class 0	0		4	mA
Inrush current-limit			140		mA
Operating current-limit			550		mA
DC-TO-DC CONVERTER					
Output voltage	$V_{IN} = 48\text{ V}, I_{LOAD} \leq I_{LOAD}(\text{max})$		5		V
Output current	$37\text{ V} \leq V_{IN} \leq 57\text{ V}$		2.3		A
Output ripple voltage peak-to-peak	$V_{IN} = 48\text{ V}, I_{LOAD} = 1\text{ A}$		34		mV
Efficiency, end-to-end	$V_{IN} = 48\text{ V}, I_{LOAD} = 230\text{ mA}$		61		%
	$V_{IN} = 48\text{ V}, I_{LOAD} = 1.15\text{ A}$		85		
	$V_{IN} = 48\text{ V}, I_{LOAD} = 2.3\text{ A}$		87		
Switching frequency			250		kHz

3 Description

The TPS23758EVM-080 enables full evaluation of the TPS23758 device. Refer to the schematic shown in [Figure 4-1](#). Ethernet power is applied from J1 and is dropped to the bridge rectifier (D1, D2). The Power over Ethernet (PoE) transformer needed to transfer power or data is T1. The Bob Smith Terminations help balance the Ethernet cable impedance and are critical for ESD and EMI or EMC performance. The EMI or EMC filter and transient protection for the TPS23758 device are at the output of the diode bridge.

Input power can also be applied at J4 from a DC source when power at J1 is not present.

The TPS23758 (U1) PD and DC-to-DC converter circuitry is shown in [Figure 4-1](#). R17 provides the detection signature. The switched side of the PD controller is to the right of U1. The TPS23758 RTN pin provides inrush limited turn on and charge of the bulk capacitor, C18.

The DC-to-DC converter is a high-efficiency diode rectified primary-side regulated flyback converter.

Output voltage feedback is provided with R19 and R24 on the bias winding. R16 provides a means for error injection to measure the frequency response of the converter.

4 Schematic

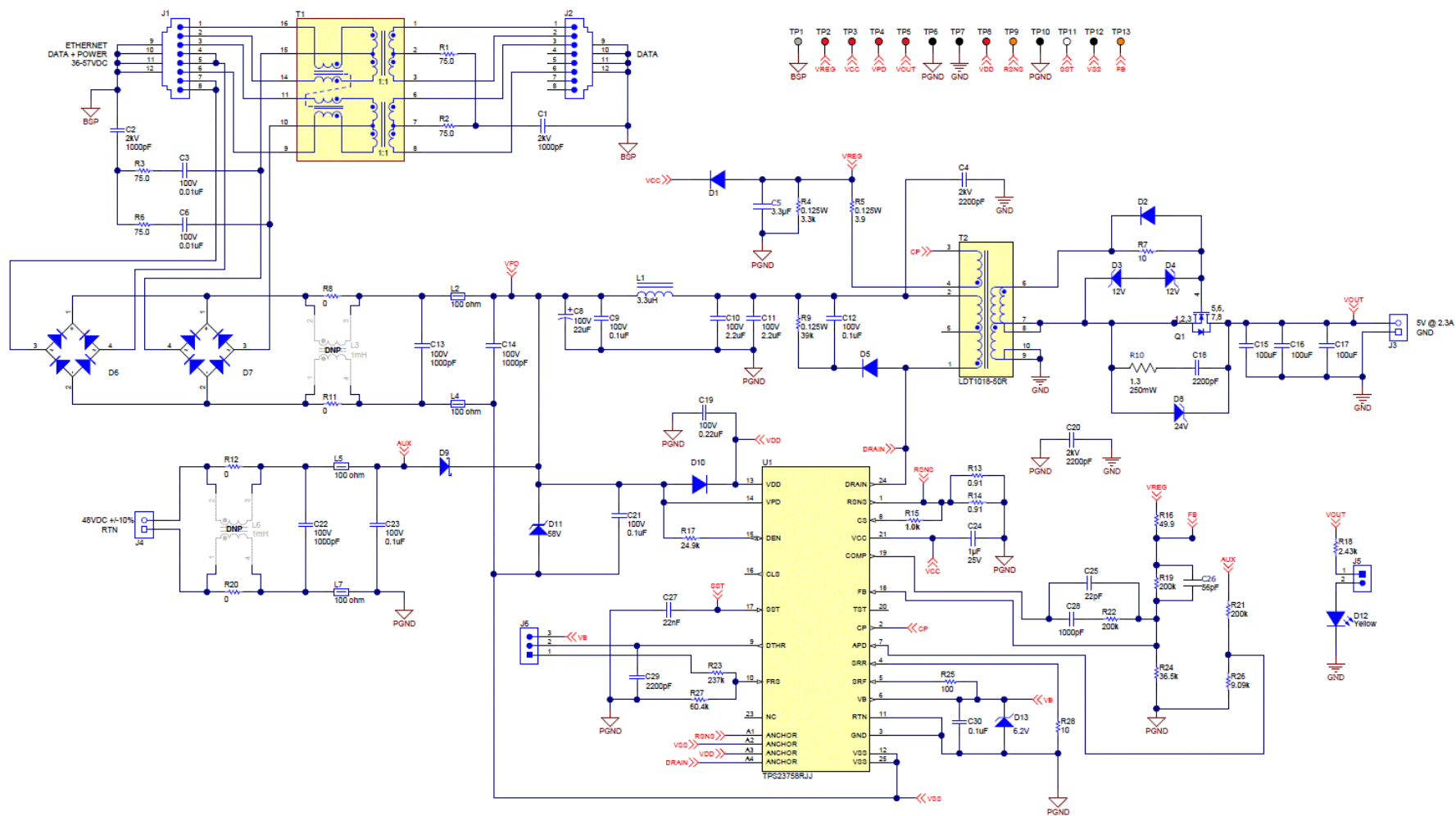

Figure 4-1. TPS23758EVM-080 Schematic

5 General Configuration and Description

5.1 Physical Access

Table 5-1 lists the EVM connector functionality. Table 5-2 describes the test point availability and jumper functionality.

Table 5-1. Connector Functionality

Connector	Label	Description
J1	PWR+DATA	PoE input; connect to PSE power and data source.
J2	DATA	Ethernet data passthrough; connect to downstream Ethernet device.
J3	Output	Output connector to load.
J4	Adapter Input	DC-to-DC converter input bypassing the PoE converter; connect a 12-V adapter.
J5	LED	Jump J4 to visually indicate the output voltage.
J6	FREQ	Jump to 'Fixed' for fixed frequency. Jump to 'Dither' to enable spread spectrum dithering.

Table 5-2. Test Points

Test Point	Label	Description
TP1	BS	Bob Smith termination
TP2	VREG	Bias winding
TP3	VCC	Switching supply voltage
TP4	VPD	Input voltage
TP5	VOUT	Output voltage
TP6, TP10	PGND	Primary ground
TP7	GND	Secondary ground
TP8	VDD	DC-DC converter input
TP9	RSNS	Current sense voltage
TP11	SST	Soft start and hiccup timer
TP12	VSS	PoE input return ground
TP13	FB	Feedback loop

6 TPS23758EVM-080 Performance Data

6.1 Startup to PSE and DCDC Startup

Figure 6-1 shows the startup response of the TPS23758EVM-080.

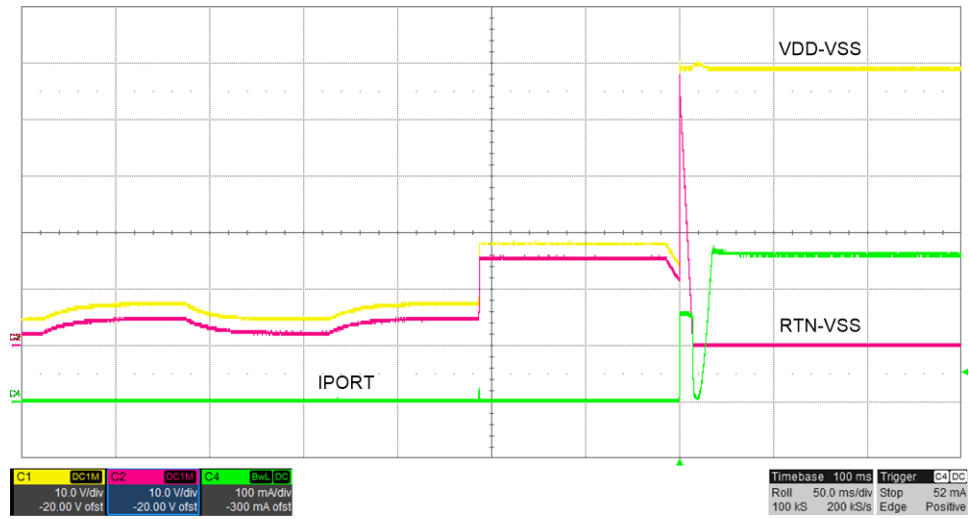

Figure 6-1. Startup Response When Connected to a PoE PSE (TPS23880)

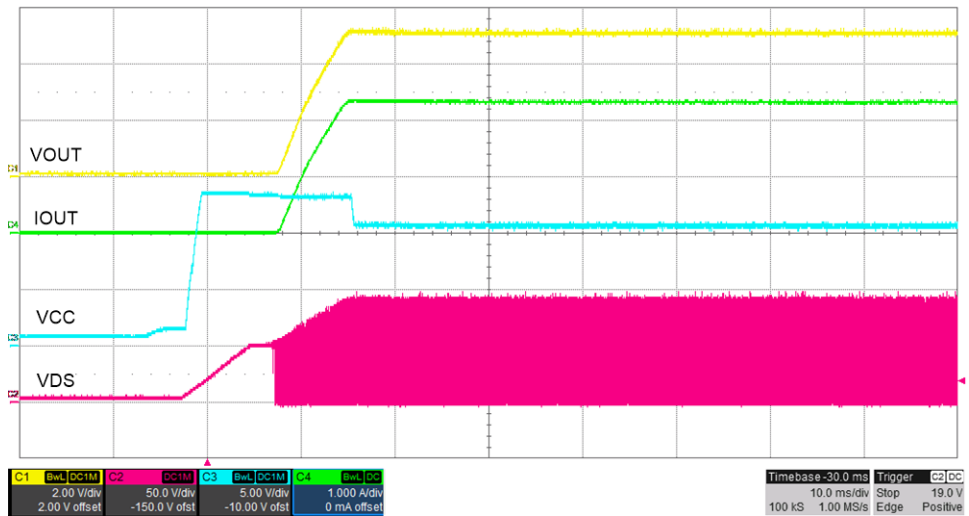

Figure 6-2. DCDC Startup

6.2 Transient Response

Figure 6-3 shows the transient response of the TPS23758EVM-080.

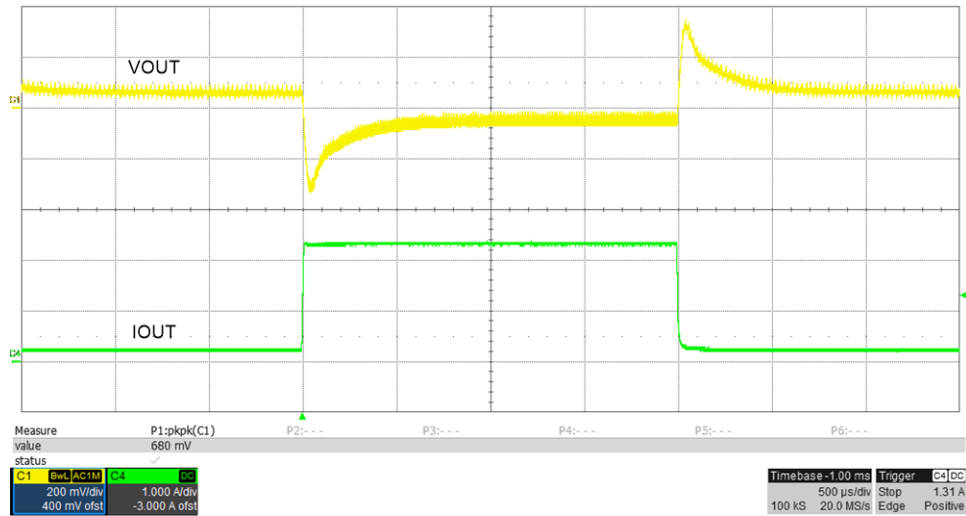

Figure 6-3. Transient Response from 100 mA to 1 A for a 48-V Input

6.3 Efficiency

Figure 6-4 shows the efficiency of the TPS23758EVM-080.

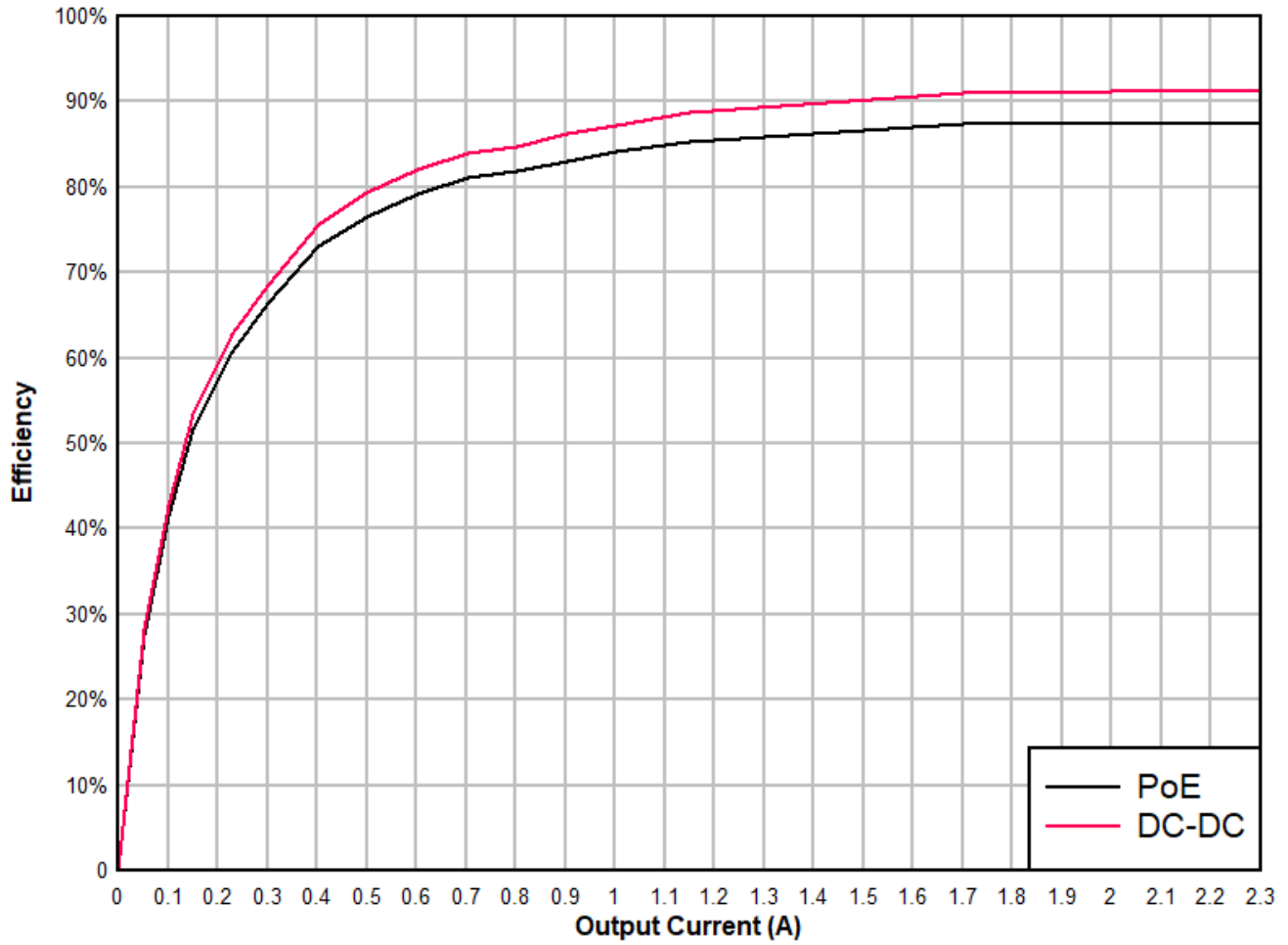

Figure 6-4. Efficiency of the TPS23758EVM-080

6.4 Load Regulation

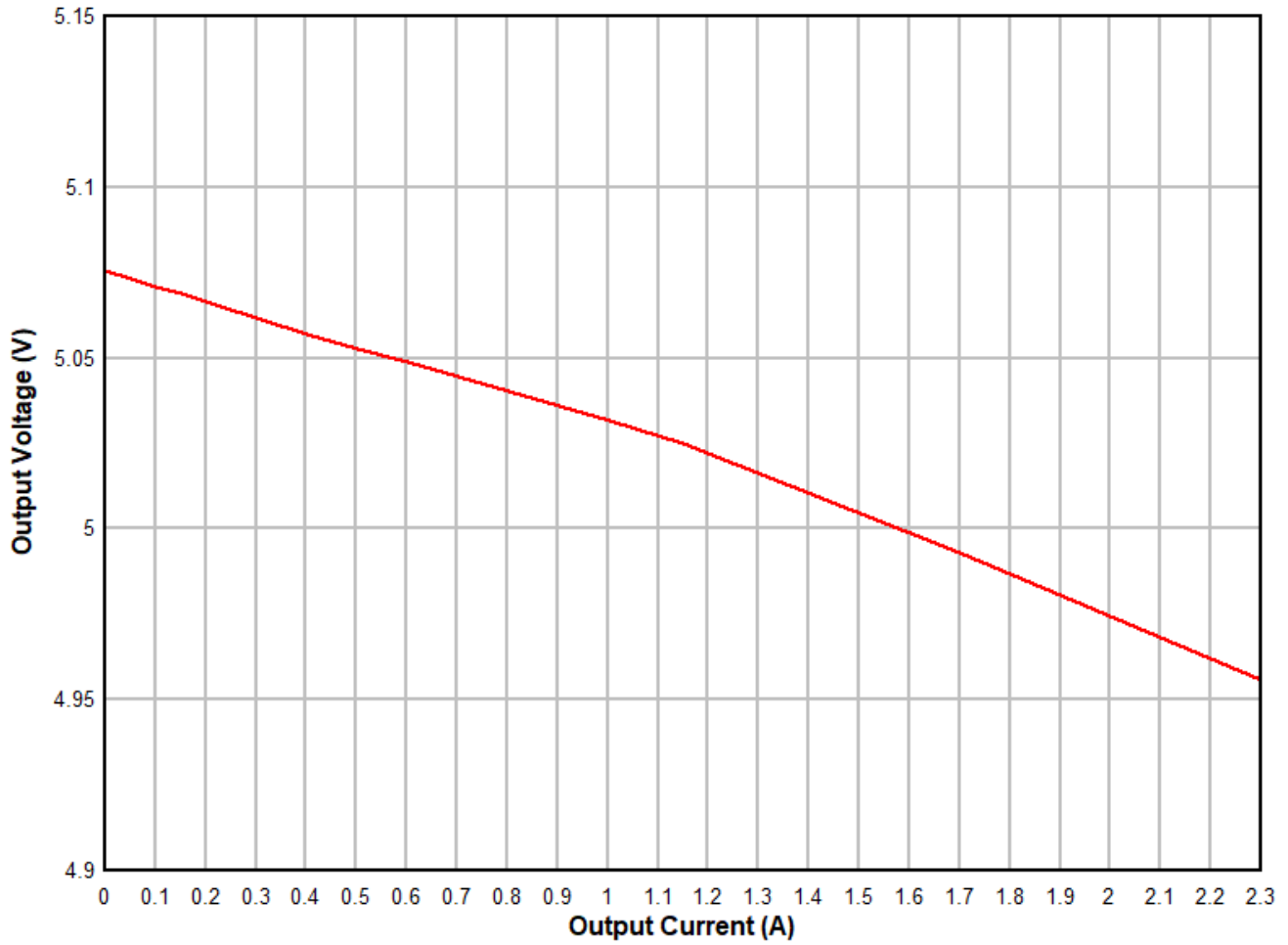

Figure 6-5. TPS23758EVM-080 Load Regulation

6.5 Recovery from VOUT Short

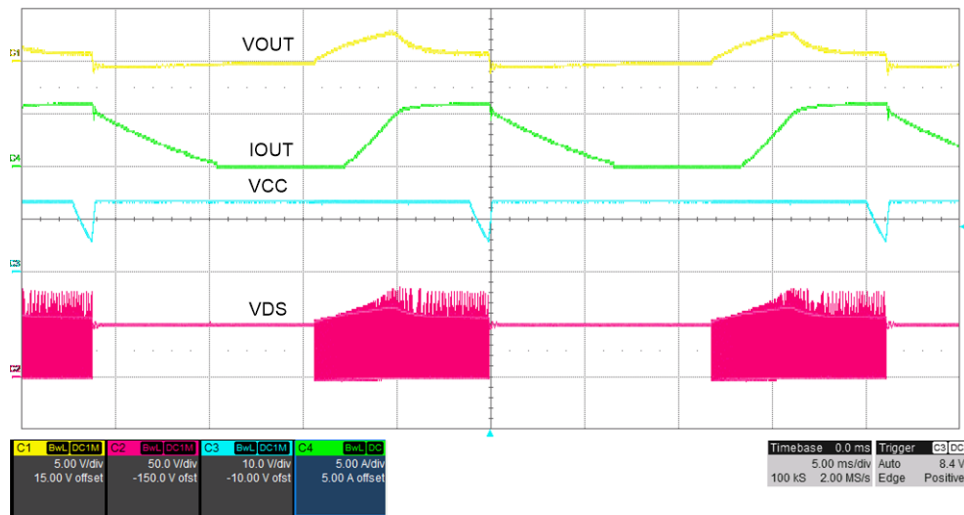

Figure 6-6. DCDC Recovery from Output Short

6.6 Slew Rate Adjust

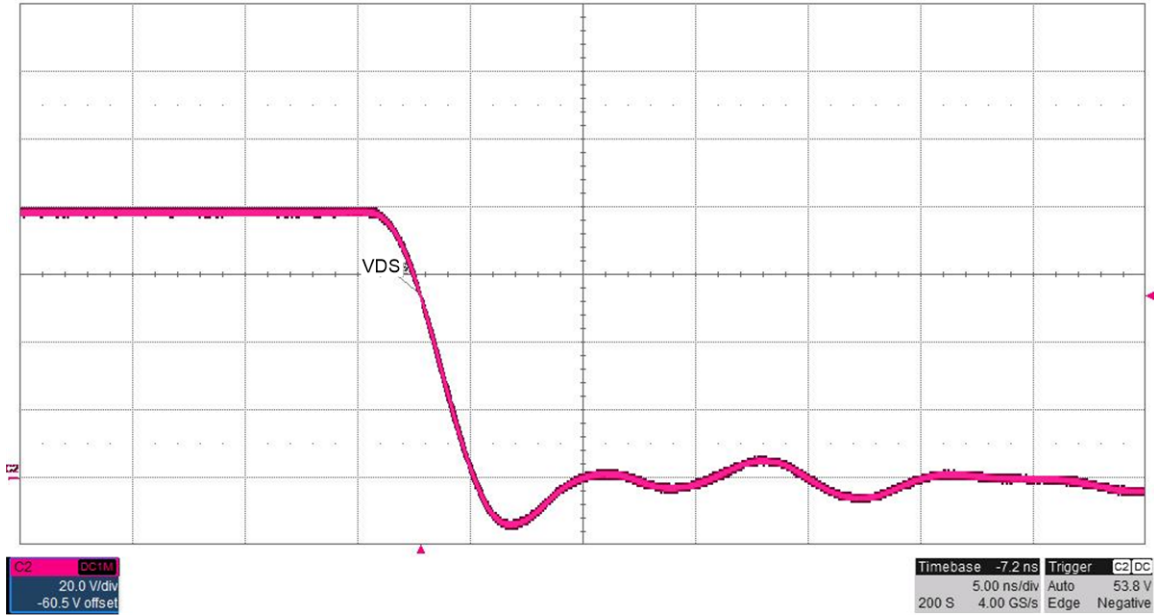

Figure 6-7. SRF = 0 Ω

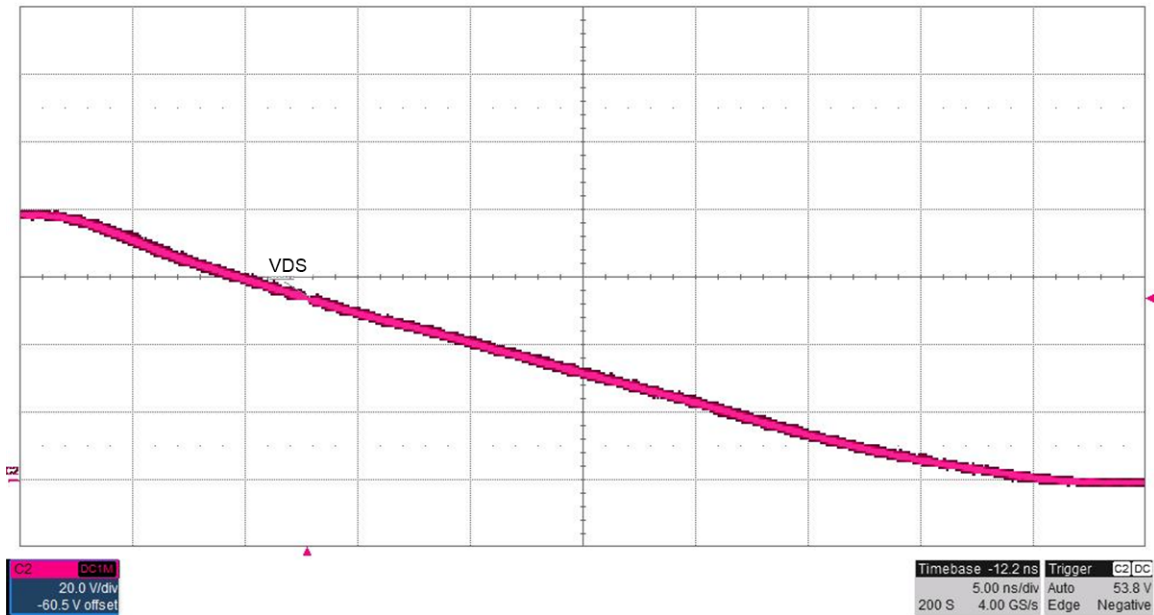

Figure 6-8. SRF = 100 Ω

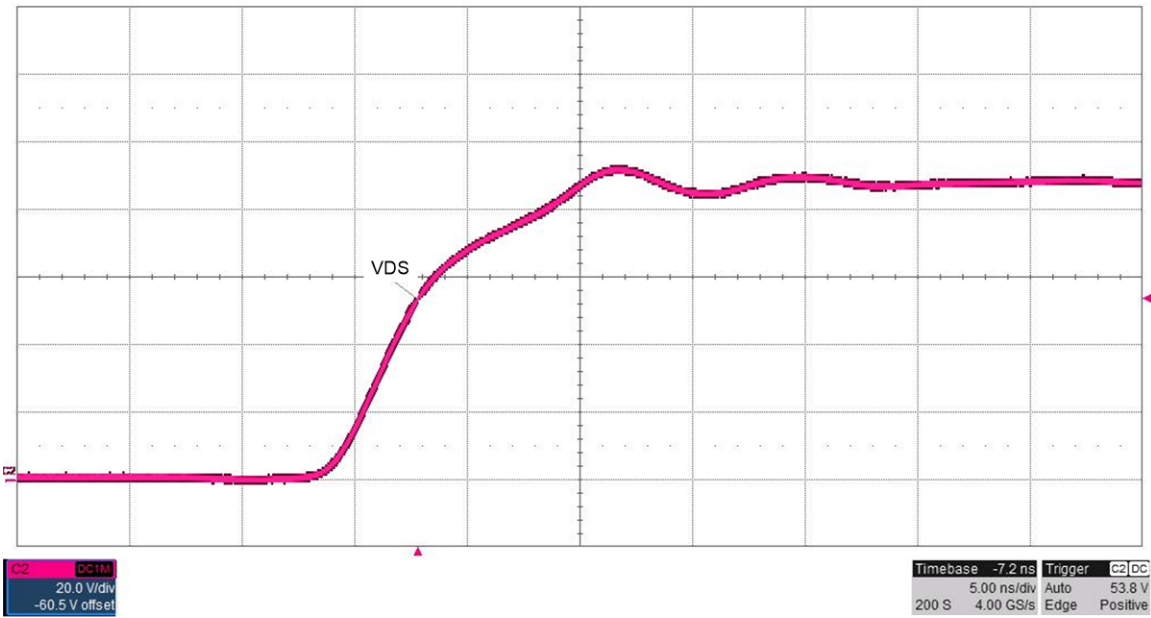

Figure 6-9. SRR = 0 Ω

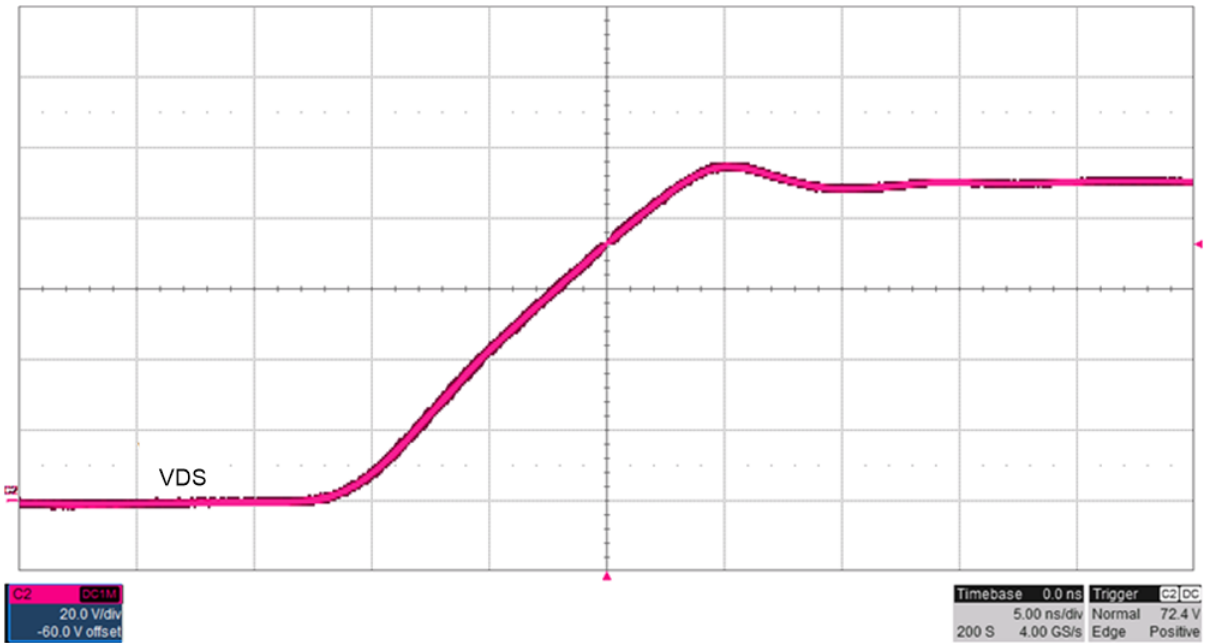

Figure 6-10. SRR = 10 Ω

7 EVM Assembly Drawings and Layout Guidelines

7.1 PCB Drawings

Figure 7-1 to Figure 7-4 show the component placement and layout of the TPS23758EVM-080.

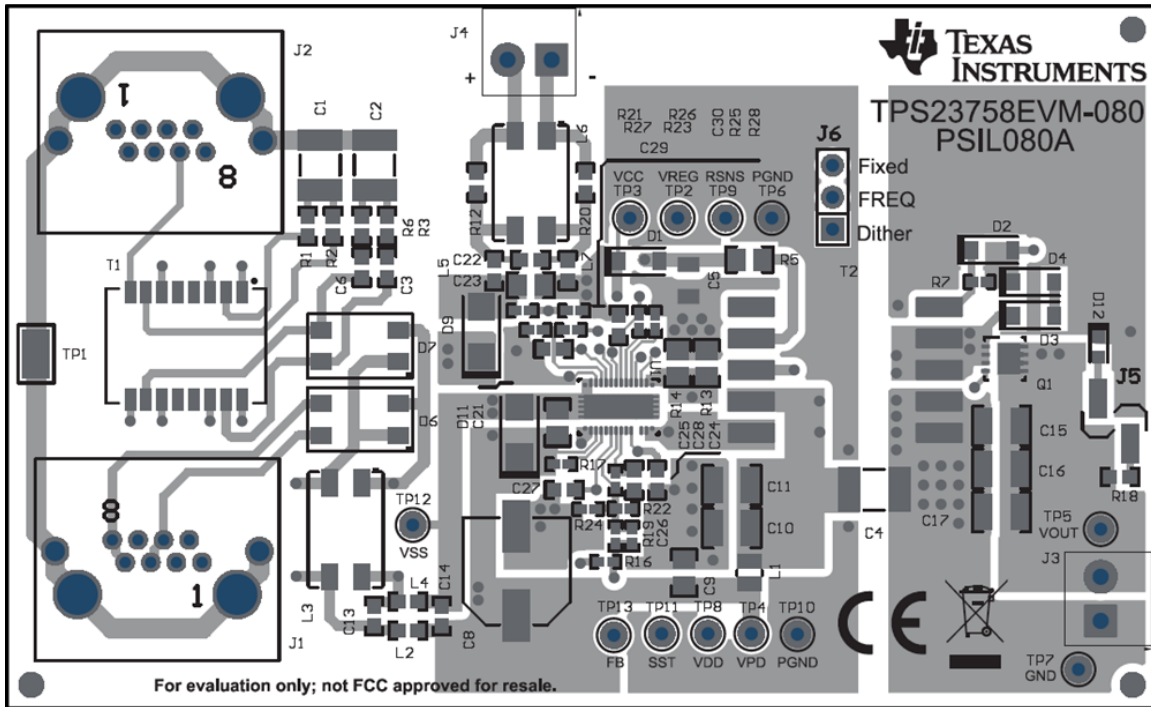

Figure 7-1. Top-Side Component Placement

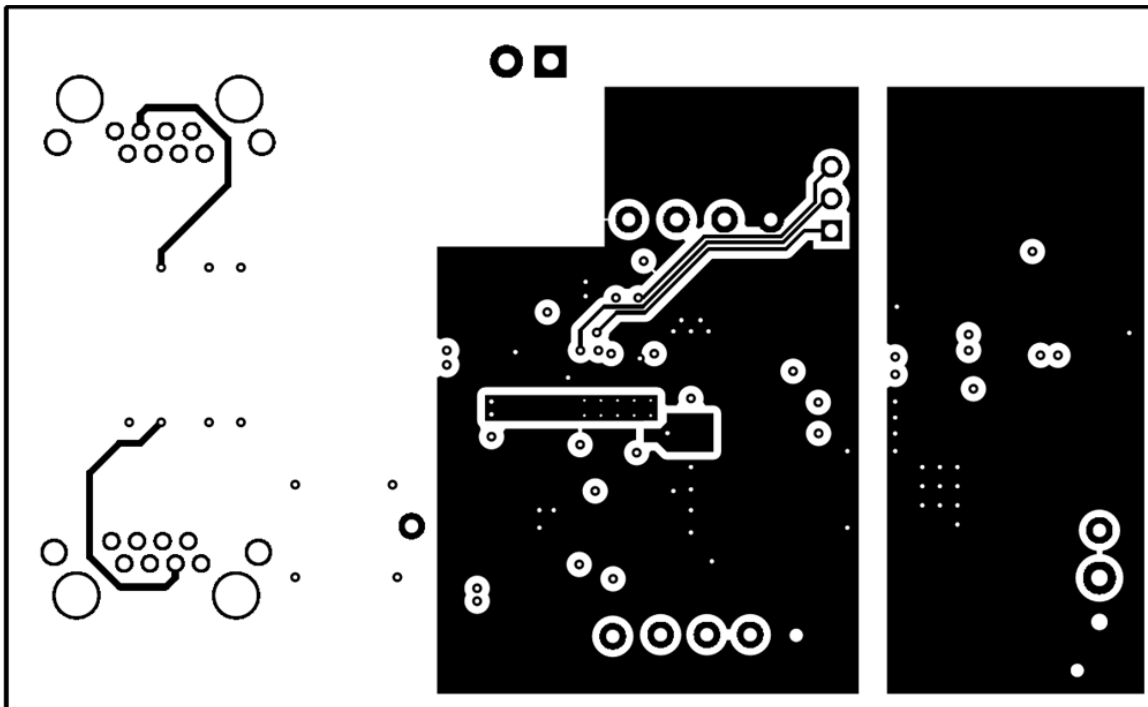

Figure 7-2. Layer 2 Routing

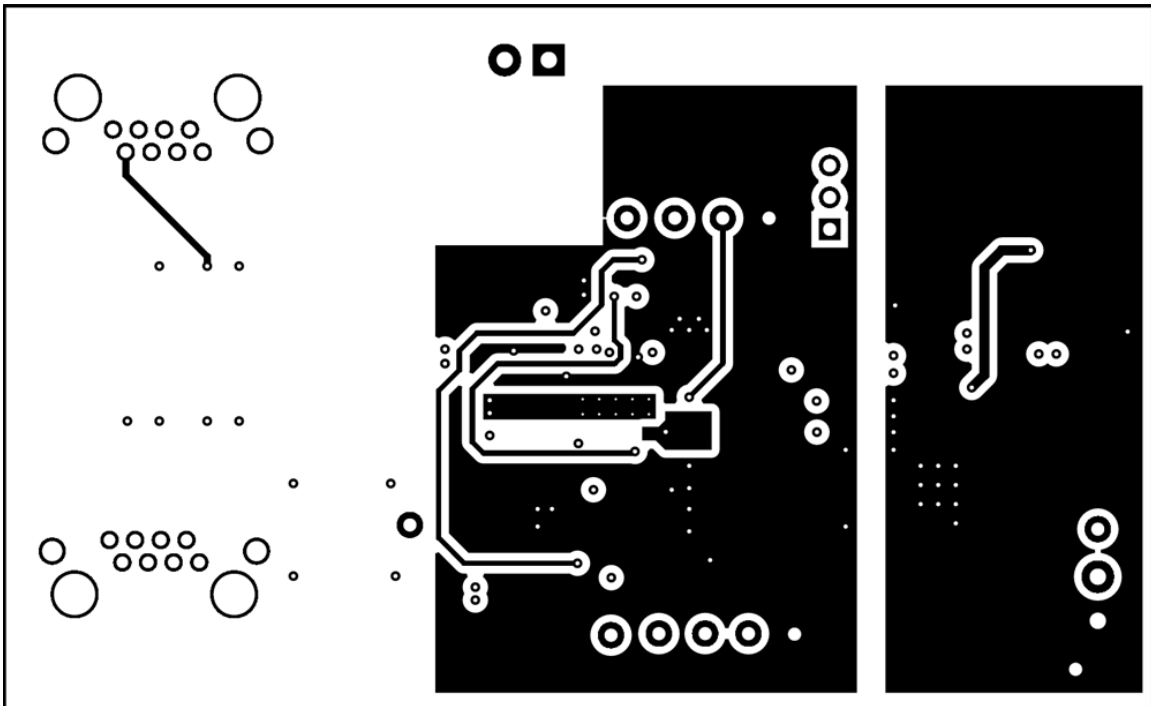

Figure 7-3. Layer 3 Routing

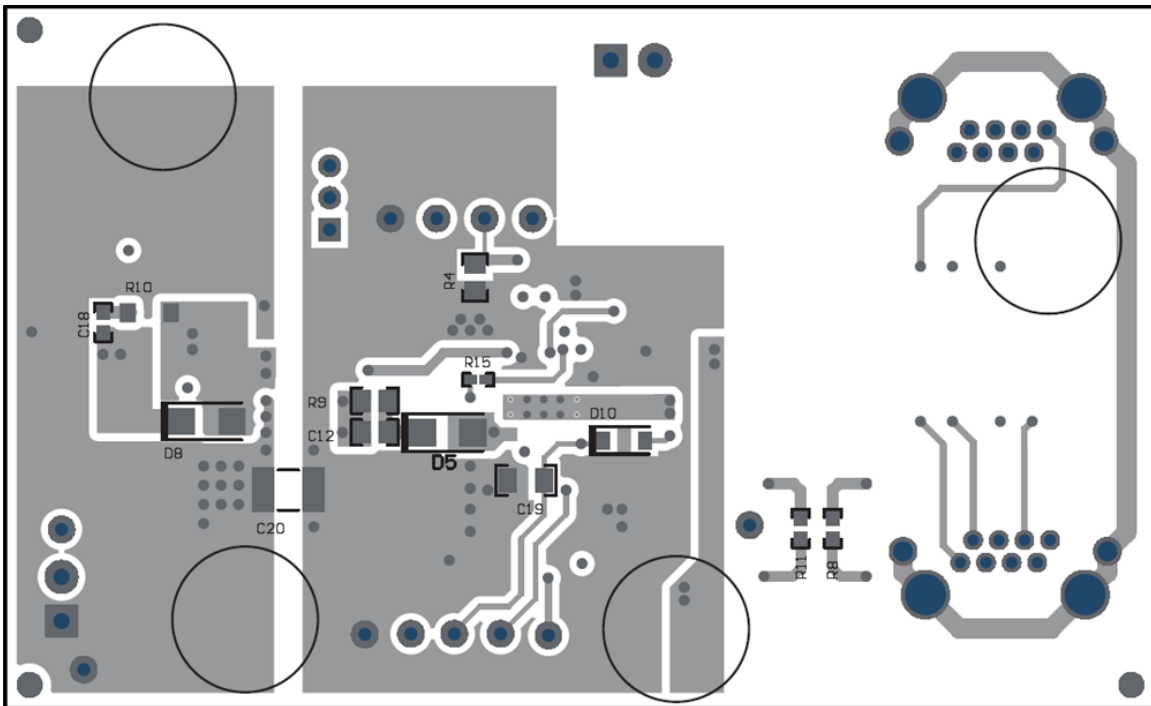

Figure 7-4. Bottom-Side Routing

7.2 Layout Guidelines

The layout of the PoE front end should follow power and EMI or ESD best-practice guidelines. A basic set of recommendations includes:

- Pin 22 of the TPS23758 is omitted from the IC to ensure high voltage clearance from Pin 24 (DRAIN). Therefore, the Pin 22 footprint should be removed when laying out the TPS23758.
- It is recommended having at least 8 vias (VSS) connecting the exposed thermal pad through a top layer plane (2 oz copper recommended) to a bottom VSS plane (2 oz. copper recommended) to help with thermal dissipation.
- The Pin 24 of the TPS23758 should be near the power transformer and the current sense resistor should be close to Pin 1 of the TPS23758 to minimize the primary loop.
- Parts placement must be driven by power flow in a point-to-point manner; RJ-45, Ethernet transformer, diode bridges, TVS and 0.1- μ F capacitor, and TPS23758 converter input bulk capacitor.
- Make all leads as short as possible with wide power traces and paired signal and return.
- No crossovers of signals from one part of the flow to another are allowed.
- Spacing consistent with safety standards like IEC60950 must be observed between the 48-V input voltage rails and between the input and an isolated converter output.
- Use large copper fills and traces on SMT power-dissipating devices, and use wide traces or overlay copper fills in the power path.

The DC-to-DC converter layout benefits from basic rules such as:

- Having at least 4 vias (VDD) near the power transformer pin connected to VDD through multiple layer planes to help with thermal dissipation of the power transformer.
- Having at least 6 vias (secondary ground) near the power transformer pin connected to secondary ground through multiple layer planes to help with thermal dissipation of the power transformer.
- Pair signals to reduce emissions and noise, especially the paths that carry high-current pulses, which include the power semiconductors and magnetics.
- Minimize the trace length of high current power semiconductors and magnetic components.
- Use the ground plane for the switching currents carefully.
- Keep the high-current and high-voltage switching away from low-level sensing circuits including those outside the power supply.
- Proper spacing around the high-voltage sections of the converter.

7.3 EMI Containment

- Use compact loops for dv/dt and di/dt circuit paths (power loops and gate drives).
- Use minimal, yet thermally adequate, copper areas for heat sinking of components tied to switching nodes (minimize exposed radiating surface). Hide copper associated with switching nodes under shielded magnetics, where possible.
- Use copper ground planes (possible stitching) and top-layer copper floods (surround circuitry with ground floods).
- Use a 4-layer PCB, if economically feasible (for better grounding).
- Minimize the amount of copper area associated with input traces (to minimize radiated pickup).
- Heat sink the quiet side of components instead of the switching side, where possible (like the output side of inductor).
- Use Bob Smith terminations, Bob Smith EFT capacitor, and Bob Smith plane. Use Bob Smith plane as a ground shield on input side of PCB (creating a phantom or literal earth ground).
- Use LC filter at DC-to-DC input.
- Dampen high-frequency ringing on all switching nodes, if present (allow for possible snubbers).
- Control rise times with gate-drive resistors and possibly snubbers.
- Switching frequency considerations.
- Use of EMI bridge capacitor across isolation boundary (isolated topologies).
- Observe the polarity dot on inductors (embed noisy end).
- Use of ferrite beads on input (allow for possible use of beads or $0-\Omega$ resistors).
- Maintain physical separation between input-related circuitry and power circuitry (use ferrite beads as boundary line).
- Balance efficiency versus acceptable noise margin.
- Possible use of common-mode inductors.
- Possible use of integrated RJ-45 jacks (shielded with internal transformer and Bob Smith terminations).
- End-product enclosure considerations (shielding).

8 Bill of Materials

Table 8-1 details the EVM bill of materials.

Table 8-1. TPS23758EVM-080 BOM

Designator	Quantity	Value	Description	PackageReference	PartNumber	Manufacturer	Alternate PartNumber	Alternate Manufacturer
!PCB1	1		Printed Circuit Board		PSIL080	Any		
C1, C2	2	1000 pF	CAP, CERM, 1000 pF, 2000 V, +/- 10%, X7R, 1812	1812	1812GC102KAT1A	AVX		
C3, C6	2	0.01 uF	CAP, CERM, 0.01 uF, 100 V, +/- 10%, X7R, 0603	0603	06031C103KAT2A	AVX		
C4, C20	2	2200 pF	CAP, CERM, 2200 pF, 2000 V, +/- 10%, X7R, 1812	1812	C4532X7R3D222K130KA	TDK		
C5	1		CAP CER 3.3 UF 25 V X7R 1206	1206	CL31B335KAHV PNE	Samsung		
C8	1	22 uF	CAP, AL, 22 uF, 100 V, +/- 20%, 1.3 ohm, AEC-Q200 Grade 2, SMD	SMT Radial F	EEE-FK2A220P	Panasonic		
C9, C12, C21, C23	4	0.1 uF	CAP, CERM, 0.1 uF, 100 V, +/- 10%, X7R, 0805	0805	C2012X7R2A104K125AA	TDK		
C10, C11	2	2.2 uF	CAP, CERM, 2.2 uF, 100 V, +/- 10%, X7R, AEC-Q200 Grade 1,		CGA6N3X7R2A25K230AB	TDK		
C13, C14, C22	3	1000 pF	CAP, CERM, 1000 pF, 100 V, +/- 10%, X7R, 0603	0603	C1608X7R2A102K080AA	TDK		
C15, C16, C17	3	100 uF	CAP, CERM, 100 uF, 10 V, +/- 20%, X5R, 1210	1210	GRM32ER61A107ME20L	MuRata		
C18, C29	2	2200 pF	CAP, CERM, 2200 pF, 50 V, +/- 10%, X7R, 0603	0603	C0603C222K5RAC	Kemet		
C19	1	0.22 uF	CAP, CERM, 0.22 uF, 100 V, +/- 10%, X7R, 1206	1206	C3216X7R2A224K115AA	TDK		

Table 8-1. TPS23758EVM-080 BOM (continued)

Designator	Quantity	Value	Description	PackageReference	PartNumber	Manufacturer	Alternate PartNumber	Alternate Manufacturer
C24	1	1 uF	CAP, CERM, 1 uF, 25 V, +/- 10%, X7R, AEC-Q200 Grade 1, 0603	0603	GCM188R71E10 5KA64D	MuRata		
C25	1	22 pF	CAP, CERM, 22 pF, 50 V, +/- 5%, C0G/NP0, AEC-Q200 Grade 1, 0402	0402	CGA2B2NP01H2 20J050BA	TDK		
C26	1		Cap Ceramic 56pF 50V C0G 5% SMD 0402 125C Paper T/R	0402 (1005 Metric)	CL05C560JB5N NNC	Samsung		
C27	1	0.022 uF	CAP, CERM, 0.022 uF, 16 V, +/- 10%, X7R, 0603	0603	C0603C223K4R ACTU	Kemet		
C28	1	1000 pF	CAP, CERM, 1000 pF, 50 V, +/- 5%, X7R, 0603	0603	CL10C102JB8N NNC	Samsung Electro-Mechanics		
C30	1	0.1 uF	CAP, CERM, 0.1 uF, 25 V, +/- 10%, X7R, AEC-Q200 Grade 1, 0603	0603	CGA3E2X7R1E1 04K080AA	TDK		
D1, D2, D10	3	100 V	Diode, Switching, 100 V, 0.2 A, SOD-123	SOD-123	MMSD4148T1G	ON Semiconductor		
D3, D4	2	12 V	Diode, Zener, 12 V, 500 mW, SOD-123	SOD-123	MMSZ5242B-7-F	Diodes Inc.		
D5	1	200 V	Diode, Ultrafast, 200 V, 1 A, SMA	SMA	MURA120T3G	ON Semiconductor		
D6, D7	2	100 V	Diode, Switching-Bridge, 100 V, 0.8 A, MiniDIP	MiniDIP	HD01-T	Diodes Inc.		
D8	1	24 V	Diode, Zener, 24 V, 1 W, SMA	SMA	SMAZ24-13-F	Diodes Inc.		
D9	1	100 V	Diode, Schottky, 100 V, 1 A, SMA	SMA	B1100-13-F	Diodes Inc.		
D11	1	58 V	Diode, TVS, Uni, 58 V, SMA	SMA	SMAJ58A-13-F	Diodes Inc.		
D12	1	Yellow	LED, Yellow, SMD	LED_0603	150060YS75000	Würth Elektronik		
D13	1	6.2 V	Diode, Zener, 6.2 V, 500 mW, SOD-123	SOD-123	MMSZ5234B-7-F	Diodes Inc.		

Table 8-1. TPS23758EVM-080 BOM (continued)

Designator	Quantity	Value	Description	PackageReference	PartNumber	Manufacturer	Alternate PartNumber	Alternate Manufacturer
H1, H2, H3, H4	4		Bumpon, Hemisphere, 0.44 X 0.20, Clear	Transparent Bumpon	SJ-5303 (CLEAR)	3M		
J1, J2	2		RJ45, No LED, tab up, R/A, TH	16.26 x 14.54 x 15.75	1-406541-1	TE Connectivity		
J3, J4	2		Terminal Block, 3.5 mm Pitch, 2x1, TH	7.0 x 8.2 x 6.5 mm	ED555/2DS	On-Shore Technology		
J5	1		Header, 2.54 mm, 2 x 1, Gold, R/A, SMT	Header, 2.54 mm, 2 x 1, R/A, SMT	878980204	Molex		
J6	1		Header, 100 mil, 3x1, Gold, TH	PBC03SAAN	PBC03SAAN	Sullins Connector Solutions		
L1	1	3.3 uH	Inductor, Shielded, Composite, 3.3 uH, 0.72 A, 0.28 ohm, SMD	SMD, 2.2 x 1.45 mm	PFL2015-332ME B	Coilcraft		
L2, L4, L5, L7	4	100 ohm	Ferrite Bead, 100 ohm @ 100 MHz, 1 A, 0603	0603	MPZ1608D101B TD25	TDK		
Q1	1	30 V	MOSFET, N-CH, 30 V, 20 A, DNH0008A (VSONP-8)	DNH0008A	CSD17579Q3A	Texas Instruments		None
R1, R2, R3, R6	4	75.0	RES, 75.0, 1%, 0.1 W, 0603	0603	RC0603FR-0775 RL	Yageo America		
R4	1	3.3 k	RES, 3.3 k, 5%, 0.125 W, 0805	0805	ERJ-6GEYJ332V	Panasonic		
R5	1	3.9	RES, 3.9, 5%, 0.125 W, AEC-Q200 Grade 0, 0805	0805	CRCW08053R90 JNEA	Vishay-Dale		
R7, R28	2	10	RES, 10, 5%, 0.063 W, AEC-Q200 Grade 0, 0402	0402	CRCW040210R0 JNED	Vishay-Dale		
R8, R11, R12, R20	4	0	RES, 0, 5%, 0.1 W, 0603	0603	ERJ-3GEY0R00 V	Panasonic		
R9	1	39 k	RES, 39 k, 5%, 0.125 W, 0805	0805	ERJ-6GEYJ393V	Panasonic		
R10	1		RES SMD 1.3 OHM 5% 1/4W 1206	1206	ERJ-8GEYJ1R3V	Panasonic		
R13, R14	2	0.91	RES, 0.91, 1%, 0.25 W, 0805	0805	CRM0805-FX-R910ELF	Bourns		

Table 8-1. TPS23758EVM-080 BOM (continued)

Designator	Quantity	Value	Description	PackageReference	PartNumber	Manufacturer	Alternate PartNumber	Alternate Manufacturer
R15	1	0	RES, 1.0 K, 5%, 0.063 W, AEC-Q200 Grade 0, 0402	0402	CRCW04020000 Z0ED	Vishay-Dale		
R16	1	49.9	RES, 49.9, 1%, 0.063 W, 0402	0402	RC0402FR-0749 R9L	Yageo America		
R17	1	24.9 k	RES, 24.9 k, 1%, 0.063 W, AEC-Q200 Grade 0, 0402	0402	CRCW040224K9 FKED	Vishay-Dale		
R18	1	2.43 k	RES, 2.43 k, 1%, 0.1 W, AEC-Q200 Grade 0, 0603	0603	CRCW06032K43 FKEA	Vishay-Dale		
R19, R22	2	200 k	RES, 200 k, 1%, 0.1 W, 0402	0402	ERJ-2RKF2003X	Panasonic		
R21	1	200 k	RES, 200 k, 1%, 0.063 W, AEC-Q200 Grade 0, 0402	0402	CRCW0402200K FKED	Vishay-Dale		
R23	1	237 k	RES, 237 k, 1%, 0.063 W, AEC-Q200 Grade 0, 0402	0402	CRCW0402237K FKED	Vishay-Dale		
R24	1	36.5 k	RES, 36.5 k, 1%, 0.063 W, AEC-Q200 Grade 0, 0402	0402	CRCW040236K5 FKED	Vishay-Dale		
R25	1	100	RES, 100, 5%, 0.1 W, AEC-Q200 Grade 0, 0402	0402	ERJ-2GEJ101X	Panasonic		
R26	1	9.09 k	RES, 9.09 k, 5%, 0.063 W, AEC-Q200 Grade 0, 0402	0402	CRCW04029K09 FKED	Vishay-Dale		
R27	1	60.4 k	RES, 60.4 k, 1%, 0.063 W, AEC-Q200 Grade 0, 0402	0402	CRCW040260K4 FKED	Vishay-Dale		
R29	1	45.3	RES, 45.3, 1%, 0.1 W, AEC-Q200 Grade 0, 0603	0603	CRCW060345R3 FKEA	Vishay-Dale		
SH-J1, SH-J2	2		Shunt, 2.54 mm, Gold, Black	Shunt, 2.54 mm, Black	60900213421	Würth Elektronik		

Table 8-1. TPS23758EVM-080 BOM (continued)

Designator	Quantity	Value	Description	PackageReference	PartNumber	Manufacturer	Alternate PartNumber	Alternate Manufacturer
T1	1	350 uH	Transformer, 350 uH, SMT	358 x 236 x 500 mil	H2019FNLT	Pulse Engineering		
T2	1	150 uH	Transformer, 150 uH, SMT	14 x 16.2 mm	LDT1018-50R	Linkcom Manufacturing Co.	750318525	Würth Elektronik
TP1	1		Test Point, Miniature, SMT	Test Point, Miniature, SMT	5019	Keystone		
TP2, TP3, TP4, TP5, TP8	5		Test Point, Miniature, Red, TH	Red Miniature Testpoint	5000	Keystone		
TP6, TP7, TP10, TP12	4		Test Point, Miniature, Black, TH	Black Miniature Testpoint	5001	Keystone		
TP9, TP13	2		Test Point, Miniature, Orange, TH	Orange Miniature Testpoint	5003	Keystone		
TP11	1		Test Point, Miniature, White, TH	White Miniature Testpoint	5002	Keystone		
U1	1		IEEE 802.3at PoE PD with No-Opto Flyback DC-DC Controller, RJJ0023B (VSON-23)	RJJ0023B	TPS23758RJJ	Texas Instruments		Texas Instruments
FID1, FID2, FID3, FID4, FID5, FID6	0		Fiducial mark. There is nothing to buy or mount.	N/A	N/A	N/A		
L3, L6	0	1 mH	Coupled inductor, 1 mH, 0.8 A, 0.31 ohm, SMD	9.2 x 6 mm	744222	Würth Elektronik		

9 Revision History

NOTE: Page numbers for previous revisions may differ from page numbers in the current version.

Changes from Revision A (August 2019) to Revision B (December 2020)	Page
• Updated the numbering format for tables, figures and cross-references throughout the document.....	2
• Updated Schematic.....	4
• Updated Bill of Materials.....	16

STANDARD TERMS FOR EVALUATION MODULES

1. *Delivery:* TI delivers TI evaluation boards, kits, or modules, including any accompanying demonstration software, components, and/or documentation which may be provided together or separately (collectively, an "EVM" or "EVMs") to the User ("User") in accordance with the terms set forth herein. User's acceptance of the EVM is expressly subject to the following terms.
 - 1.1 EVMs are intended solely for product or software developers for use in a research and development setting to facilitate feasibility evaluation, experimentation, or scientific analysis of TI semiconductors products. EVMs have no direct function and are not finished products. EVMs shall not be directly or indirectly assembled as a part or subassembly in any finished product. For clarification, any software or software tools provided with the EVM ("Software") shall not be subject to the terms and conditions set forth herein but rather shall be subject to the applicable terms that accompany such Software
 - 1.2 EVMs are not intended for consumer or household use. EVMs may not be sold, sublicensed, leased, rented, loaned, assigned, or otherwise distributed for commercial purposes by Users, in whole or in part, or used in any finished product or production system.
2. *Limited Warranty and Related Remedies/Disclaimers:*
 - 2.1 These terms do not apply to Software. The warranty, if any, for Software is covered in the applicable Software License Agreement.
 - 2.2 TI warrants that the TI EVM will conform to TI's published specifications for ninety (90) days after the date TI delivers such EVM to User. Notwithstanding the foregoing, TI shall not be liable for a nonconforming EVM if (a) the nonconformity was caused by neglect, misuse or mistreatment by an entity other than TI, including improper installation or testing, or for any EVMs that have been altered or modified in any way by an entity other than TI, (b) the nonconformity resulted from User's design, specifications or instructions for such EVMs or improper system design, or (c) User has not paid on time. Testing and other quality control techniques are used to the extent TI deems necessary. TI does not test all parameters of each EVM. User's claims against TI under this Section 2 are void if User fails to notify TI of any apparent defects in the EVMs within ten (10) business days after delivery, or of any hidden defects with ten (10) business days after the defect has been detected.
 - 2.3 TI's sole liability shall be at its option to repair or replace EVMs that fail to conform to the warranty set forth above, or credit User's account for such EVM. TI's liability under this warranty shall be limited to EVMs that are returned during the warranty period to the address designated by TI and that are determined by TI not to conform to such warranty. If TI elects to repair or replace such EVM, TI shall have a reasonable time to repair such EVM or provide replacements. Repaired EVMs shall be warranted for the remainder of the original warranty period. Replaced EVMs shall be warranted for a new full ninety (90) day warranty period.

WARNING

Evaluation Kits are intended solely for use by technically qualified, professional electronics experts who are familiar with the dangers and application risks associated with handling electrical mechanical components, systems, and subsystems.

User shall operate the Evaluation Kit within TI's recommended guidelines and any applicable legal or environmental requirements as well as reasonable and customary safeguards. Failure to set up and/or operate the Evaluation Kit within TI's recommended guidelines may result in personal injury or death or property damage. Proper set up entails following TI's instructions for electrical ratings of interface circuits such as input, output and electrical loads.

NOTE:

EXPOSURE TO ELECTROSTATIC DISCHARGE (ESD) MAY CAUSE DEGRADATION OR FAILURE OF THE EVALUATION KIT; TI RECOMMENDS STORAGE OF THE EVALUATION KIT IN A PROTECTIVE ESD BAG.

3 Regulatory Notices:

3.1 United States

3.1.1 Notice applicable to EVMs not FCC-Approved:

FCC NOTICE: This kit is designed to allow product developers to evaluate electronic components, circuitry, or software associated with the kit to determine whether to incorporate such items in a finished product and software developers to write software applications for use with the end product. This kit is not a finished product and when assembled may not be resold or otherwise marketed unless all required FCC equipment authorizations are first obtained. Operation is subject to the condition that this product not cause harmful interference to licensed radio stations and that this product accept harmful interference. Unless the assembled kit is designed to operate under part 15, part 18 or part 95 of this chapter, the operator of the kit must operate under the authority of an FCC license holder or must secure an experimental authorization under part 5 of this chapter.

3.1.2 For EVMs annotated as FCC – FEDERAL COMMUNICATIONS COMMISSION Part 15 Compliant:

CAUTION

This device complies with part 15 of the FCC Rules. Operation is subject to the following two conditions: (1) This device may not cause harmful interference, and (2) this device must accept any interference received, including interference that may cause undesired operation.

Changes or modifications not expressly approved by the party responsible for compliance could void the user's authority to operate the equipment.

FCC Interference Statement for Class A EVM devices

NOTE: This equipment has been tested and found to comply with the limits for a Class A digital device, pursuant to part 15 of the FCC Rules. These limits are designed to provide reasonable protection against harmful interference when the equipment is operated in a commercial environment. This equipment generates, uses, and can radiate radio frequency energy and, if not installed and used in accordance with the instruction manual, may cause harmful interference to radio communications. Operation of this equipment in a residential area is likely to cause harmful interference in which case the user will be required to correct the interference at his own expense.

FCC Interference Statement for Class B EVM devices

NOTE: This equipment has been tested and found to comply with the limits for a Class B digital device, pursuant to part 15 of the FCC Rules. These limits are designed to provide reasonable protection against harmful interference in a residential installation. This equipment generates, uses and can radiate radio frequency energy and, if not installed and used in accordance with the instructions, may cause harmful interference to radio communications. However, there is no guarantee that interference will not occur in a particular installation. If this equipment does cause harmful interference to radio or television reception, which can be determined by turning the equipment off and on, the user is encouraged to try to correct the interference by one or more of the following measures:

- Reorient or relocate the receiving antenna.
- Increase the separation between the equipment and receiver.
- Connect the equipment into an outlet on a circuit different from that to which the receiver is connected.
- Consult the dealer or an experienced radio/TV technician for help.

3.2 Canada

3.2.1 For EVMs issued with an Industry Canada Certificate of Conformance to RSS-210 or RSS-247

Concerning EVMs Including Radio Transmitters:

This device complies with Industry Canada license-exempt RSSs. Operation is subject to the following two conditions:

(1) this device may not cause interference, and (2) this device must accept any interference, including interference that may cause undesired operation of the device.

Concernant les EVMs avec appareils radio:

Le présent appareil est conforme aux CNR d'Industrie Canada applicables aux appareils radio exempts de licence. L'exploitation est autorisée aux deux conditions suivantes: (1) l'appareil ne doit pas produire de brouillage, et (2) l'utilisateur de l'appareil doit accepter tout brouillage radioélectrique subi, même si le brouillage est susceptible d'en compromettre le fonctionnement.

Concerning EVMs Including Detachable Antennas:

Under Industry Canada regulations, this radio transmitter may only operate using an antenna of a type and maximum (or lesser) gain approved for the transmitter by Industry Canada. To reduce potential radio interference to other users, the antenna type and its gain should be so chosen that the equivalent isotropically radiated power (e.i.r.p.) is not more than that necessary for successful communication. This radio transmitter has been approved by Industry Canada to operate with the antenna types listed in the user guide with the maximum permissible gain and required antenna impedance for each antenna type indicated. Antenna types not included in this list, having a gain greater than the maximum gain indicated for that type, are strictly prohibited for use with this device.

Concernant les EVMs avec antennes détachables

Conformément à la réglementation d'Industrie Canada, le présent émetteur radio peut fonctionner avec une antenne d'un type et d'un gain maximal (ou inférieur) approuvé pour l'émetteur par Industrie Canada. Dans le but de réduire les risques de brouillage radioélectrique à l'intention des autres utilisateurs, il faut choisir le type d'antenne et son gain de sorte que la puissance isotrope rayonnée équivalente (p.i.r.e.) ne dépasse pas l'intensité nécessaire à l'établissement d'une communication satisfaisante. Le présent émetteur radio a été approuvé par Industrie Canada pour fonctionner avec les types d'antenne énumérés dans le manuel d'usage et ayant un gain admissible maximal et l'impédance requise pour chaque type d'antenne. Les types d'antenne non inclus dans cette liste, ou dont le gain est supérieur au gain maximal indiqué, sont strictement interdits pour l'exploitation de l'émetteur.

3.3 Japan

3.3.1 *Notice for EVMs delivered in Japan:* Please see http://www.tij.co.jp/lstds/ti_ja/general/eStore/notice_01.page 日本国内に輸入される評価用キット、ボードについては、次のところをご覧ください。
http://www.tij.co.jp/lstds/ti_ja/general/eStore/notice_01.page

3.3.2 *Notice for Users of EVMs Considered "Radio Frequency Products" in Japan:* EVMs entering Japan may not be certified by TI as conforming to Technical Regulations of Radio Law of Japan.

If User uses EVMs in Japan, not certified to Technical Regulations of Radio Law of Japan, User is required to follow the instructions set forth by Radio Law of Japan, which includes, but is not limited to, the instructions below with respect to EVMs (which for the avoidance of doubt are stated strictly for convenience and should be verified by User):

1. Use EVMs in a shielded room or any other test facility as defined in the notification #173 issued by Ministry of Internal Affairs and Communications on March 28, 2006, based on Sub-section 1.1 of Article 6 of the Ministry's Rule for Enforcement of Radio Law of Japan,
2. Use EVMs only after User obtains the license of Test Radio Station as provided in Radio Law of Japan with respect to EVMs, or
3. Use of EVMs only after User obtains the Technical Regulations Conformity Certification as provided in Radio Law of Japan with respect to EVMs. Also, do not transfer EVMs, unless User gives the same notice above to the transferee. Please note that if User does not follow the instructions above, User will be subject to penalties of Radio Law of Japan.

【無線電波を送信する製品の開発キットをお使いになる際の注意事項】 開発キットの中には技術基準適合証明を受けていないものがあります。技術適合証明を受けていないものご使用に際しては、電波法遵守のため、以下のいずれかの措置を取っていただく必要がありますのでご注意ください。

1. 電波法施行規則第6条第1項第1号に基づく平成18年3月28日総務省告示第173号で定められた電波暗室等の試験設備でご使用いただく。
2. 実験局の免許を取得後ご使用いただく。
3. 技術基準適合証明を取得後ご使用いただく。

なお、本製品は、上記の「ご使用にあたっての注意」を譲渡先、移転先に通知しない限り、譲渡、移転できないものとします。

上記を遵守頂けない場合は、電波法の罰則が適用される可能性があることをご留意ください。日本テキサス・インスツルメンツ株式会社
東京都新宿区西新宿 6 丁目 2 4 番 1 号
西新宿三井ビル

3.3.3 *Notice for EVMs for Power Line Communication:* Please see http://www.tij.co.jp/lstds/ti_ja/general/eStore/notice_02.page
電力線搬送波通信についての開発キットをお使いになる際の注意事項については、次のところをご覧ください。http://www.tij.co.jp/lstds/ti_ja/general/eStore/notice_02.page

3.4 European Union

3.4.1 *For EVMs subject to EU Directive 2014/30/EU (Electromagnetic Compatibility Directive):*

This is a class A product intended for use in environments other than domestic environments that are connected to a low-voltage power-supply network that supplies buildings used for domestic purposes. In a domestic environment this product may cause radio interference in which case the user may be required to take adequate measures.

-
4. *EVM Use Restrictions and Warnings:*
 - 4.1 EVMS ARE NOT FOR USE IN FUNCTIONAL SAFETY AND/OR SAFETY CRITICAL EVALUATIONS, INCLUDING BUT NOT LIMITED TO EVALUATIONS OF LIFE SUPPORT APPLICATIONS.
 - 4.2 User must read and apply the user guide and other available documentation provided by TI regarding the EVM prior to handling or using the EVM, including without limitation any warning or restriction notices. The notices contain important safety information related to, for example, temperatures and voltages.
 - 4.3 *Safety-Related Warnings and Restrictions:*
 - 4.3.1 User shall operate the EVM within TI's recommended specifications and environmental considerations stated in the user guide, other available documentation provided by TI, and any other applicable requirements and employ reasonable and customary safeguards. Exceeding the specified performance ratings and specifications (including but not limited to input and output voltage, current, power, and environmental ranges) for the EVM may cause personal injury or death, or property damage. If there are questions concerning performance ratings and specifications, User should contact a TI field representative prior to connecting interface electronics including input power and intended loads. Any loads applied outside of the specified output range may also result in unintended and/or inaccurate operation and/or possible permanent damage to the EVM and/or interface electronics. Please consult the EVM user guide prior to connecting any load to the EVM output. If there is uncertainty as to the load specification, please contact a TI field representative. During normal operation, even with the inputs and outputs kept within the specified allowable ranges, some circuit components may have elevated case temperatures. These components include but are not limited to linear regulators, switching transistors, pass transistors, current sense resistors, and heat sinks, which can be identified using the information in the associated documentation. When working with the EVM, please be aware that the EVM may become very warm.
 - 4.3.2 EVMs are intended solely for use by technically qualified, professional electronics experts who are familiar with the dangers and application risks associated with handling electrical mechanical components, systems, and subsystems. User assumes all responsibility and liability for proper and safe handling and use of the EVM by User or its employees, affiliates, contractors or designees. User assumes all responsibility and liability to ensure that any interfaces (electronic and/or mechanical) between the EVM and any human body are designed with suitable isolation and means to safely limit accessible leakage currents to minimize the risk of electrical shock hazard. User assumes all responsibility and liability for any improper or unsafe handling or use of the EVM by User or its employees, affiliates, contractors or designees.
 - 4.4 User assumes all responsibility and liability to determine whether the EVM is subject to any applicable international, federal, state, or local laws and regulations related to User's handling and use of the EVM and, if applicable, User assumes all responsibility and liability for compliance in all respects with such laws and regulations. User assumes all responsibility and liability for proper disposal and recycling of the EVM consistent with all applicable international, federal, state, and local requirements.
 5. *Accuracy of Information:* To the extent TI provides information on the availability and function of EVMs, TI attempts to be as accurate as possible. However, TI does not warrant the accuracy of EVM descriptions, EVM availability or other information on its websites as accurate, complete, reliable, current, or error-free.
 6. *Disclaimers:*
 - 6.1 EXCEPT AS SET FORTH ABOVE, EVMS AND ANY MATERIALS PROVIDED WITH THE EVM (INCLUDING, BUT NOT LIMITED TO, REFERENCE DESIGNS AND THE DESIGN OF THE EVM ITSELF) ARE PROVIDED "AS IS" AND "WITH ALL FAULTS." TI DISCLAIMS ALL OTHER WARRANTIES, EXPRESS OR IMPLIED, REGARDING SUCH ITEMS, INCLUDING BUT NOT LIMITED TO ANY EPIDEMIC FAILURE WARRANTY OR IMPLIED WARRANTIES OF MERCHANTABILITY OR FITNESS FOR A PARTICULAR PURPOSE OR NON-INFRINGEMENT OF ANY THIRD PARTY PATENTS, COPYRIGHTS, TRADE SECRETS OR OTHER INTELLECTUAL PROPERTY RIGHTS.
 - 6.2 EXCEPT FOR THE LIMITED RIGHT TO USE THE EVM SET FORTH HEREIN, NOTHING IN THESE TERMS SHALL BE CONSTRUED AS GRANTING OR CONFERRING ANY RIGHTS BY LICENSE, PATENT, OR ANY OTHER INDUSTRIAL OR INTELLECTUAL PROPERTY RIGHT OF TI, ITS SUPPLIERS/LICENSORS OR ANY OTHER THIRD PARTY, TO USE THE EVM IN ANY FINISHED END-USER OR READY-TO-USE FINAL PRODUCT, OR FOR ANY INVENTION, DISCOVERY OR IMPROVEMENT, REGARDLESS OF WHEN MADE, CONCEIVED OR ACQUIRED.
 7. *USER'S INDEMNITY OBLIGATIONS AND REPRESENTATIONS.* USER WILL DEFEND, INDEMNIFY AND HOLD TI, ITS LICENSORS AND THEIR REPRESENTATIVES HARMLESS FROM AND AGAINST ANY AND ALL CLAIMS, DAMAGES, LOSSES, EXPENSES, COSTS AND LIABILITIES (COLLECTIVELY, "CLAIMS") ARISING OUT OF OR IN CONNECTION WITH ANY HANDLING OR USE OF THE EVM THAT IS NOT IN ACCORDANCE WITH THESE TERMS. THIS OBLIGATION SHALL APPLY WHETHER CLAIMS ARISE UNDER STATUTE, REGULATION, OR THE LAW OF TORT, CONTRACT OR ANY OTHER LEGAL THEORY, AND EVEN IF THE EVM FAILS TO PERFORM AS DESCRIBED OR EXPECTED.
-

8. *Limitations on Damages and Liability:*

8.1 *General Limitations.* IN NO EVENT SHALL TI BE LIABLE FOR ANY SPECIAL, COLLATERAL, INDIRECT, PUNITIVE, INCIDENTAL, CONSEQUENTIAL, OR EXEMPLARY DAMAGES IN CONNECTION WITH OR ARISING OUT OF THESE TERMS OR THE USE OF THE EVMS , REGARDLESS OF WHETHER TI HAS BEEN ADVISED OF THE POSSIBILITY OF SUCH DAMAGES. EXCLUDED DAMAGES INCLUDE, BUT ARE NOT LIMITED TO, COST OF REMOVAL OR REINSTALLATION, ANCILLARY COSTS TO THE PROCUREMENT OF SUBSTITUTE GOODS OR SERVICES, RETESTING, OUTSIDE COMPUTER TIME, LABOR COSTS, LOSS OF GOODWILL, LOSS OF PROFITS, LOSS OF SAVINGS, LOSS OF USE, LOSS OF DATA, OR BUSINESS INTERRUPTION. NO CLAIM, SUIT OR ACTION SHALL BE BROUGHT AGAINST TI MORE THAN TWELVE (12) MONTHS AFTER THE EVENT THAT GAVE RISE TO THE CAUSE OF ACTION HAS OCCURRED.

8.2 *Specific Limitations.* IN NO EVENT SHALL TI'S AGGREGATE LIABILITY FROM ANY USE OF AN EVM PROVIDED HEREUNDER, INCLUDING FROM ANY WARRANTY, INDEMNITY OR OTHER OBLIGATION ARISING OUT OF OR IN CONNECTION WITH THESE TERMS, , EXCEED THE TOTAL AMOUNT PAID TO TI BY USER FOR THE PARTICULAR EVM(S) AT ISSUE DURING THE PRIOR TWELVE (12) MONTHS WITH RESPECT TO WHICH LOSSES OR DAMAGES ARE CLAIMED. THE EXISTENCE OF MORE THAN ONE CLAIM SHALL NOT ENLARGE OR EXTEND THIS LIMIT.

9. *Return Policy.* Except as otherwise provided, TI does not offer any refunds, returns, or exchanges. Furthermore, no return of EVM(s) will be accepted if the package has been opened and no return of the EVM(s) will be accepted if they are damaged or otherwise not in a resalable condition. If User feels it has been incorrectly charged for the EVM(s) it ordered or that delivery violates the applicable order, User should contact TI. All refunds will be made in full within thirty (30) working days from the return of the components(s), excluding any postage or packaging costs.

10. *Governing Law:* These terms and conditions shall be governed by and interpreted in accordance with the laws of the State of Texas, without reference to conflict-of-laws principles. User agrees that non-exclusive jurisdiction for any dispute arising out of or relating to these terms and conditions lies within courts located in the State of Texas and consents to venue in Dallas County, Texas. Notwithstanding the foregoing, any judgment may be enforced in any United States or foreign court, and TI may seek injunctive relief in any United States or foreign court.

Mailing Address: Texas Instruments, Post Office Box 655303, Dallas, Texas 75265
Copyright © 2019, Texas Instruments Incorporated

IMPORTANT NOTICE AND DISCLAIMER

TI PROVIDES TECHNICAL AND RELIABILITY DATA (INCLUDING DATASHEETS), DESIGN RESOURCES (INCLUDING REFERENCE DESIGNS), APPLICATION OR OTHER DESIGN ADVICE, WEB TOOLS, SAFETY INFORMATION, AND OTHER RESOURCES "AS IS" AND WITH ALL FAULTS, AND DISCLAIMS ALL WARRANTIES, EXPRESS AND IMPLIED, INCLUDING WITHOUT LIMITATION ANY IMPLIED WARRANTIES OF MERCHANTABILITY, FITNESS FOR A PARTICULAR PURPOSE OR NON-INFRINGEMENT OF THIRD PARTY INTELLECTUAL PROPERTY RIGHTS.

These resources are intended for skilled developers designing with TI products. You are solely responsible for (1) selecting the appropriate TI products for your application, (2) designing, validating and testing your application, and (3) ensuring your application meets applicable standards, and any other safety, security, or other requirements. These resources are subject to change without notice. TI grants you permission to use these resources only for development of an application that uses the TI products described in the resource. Other reproduction and display of these resources is prohibited. No license is granted to any other TI intellectual property right or to any third party intellectual property right. TI disclaims responsibility for, and you will fully indemnify TI and its representatives against, any claims, damages, costs, losses, and liabilities arising out of your use of these resources.

TI's products are provided subject to TI's Terms of Sale (www.ti.com/legal/termsofsale.html) or other applicable terms available either on ti.com or provided in conjunction with such TI products. TI's provision of these resources does not expand or otherwise alter TI's applicable warranties or warranty disclaimers for TI products.

Mailing Address: Texas Instruments, Post Office Box 655303, Dallas, Texas 75265
Copyright © 2020, Texas Instruments Incorporated