

REVISIONS			
REV	DESCRIPTION, ECN, EAR NO.	DATE	APP'D
C	PRODUCT DRAWING (EAR 14804)	JUN12/20	M.P.
D	PRODUCT DRAWING (EAR 14804)	JUL24/20	M.P.

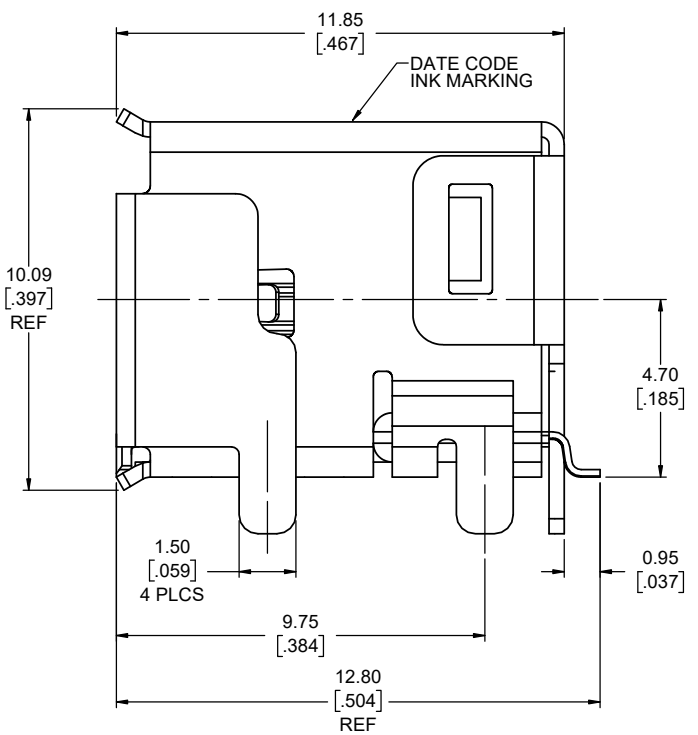

ORDERING CODE: ND9-AS1X-00

- SERIES, IX INDUSTRIAL
- TYPE A KEY FOR ETHERNET
- SOCKET / RECEPTACLE
- RIGHT ANGLE
- PLATING FOR MATING AREA
 - 2 = 0.2µm (8µ") GOLD
 - 7 = 0.76µm (30µ") PALLADIUM NICKEL WITH GOLD FLASH
- STANDARD

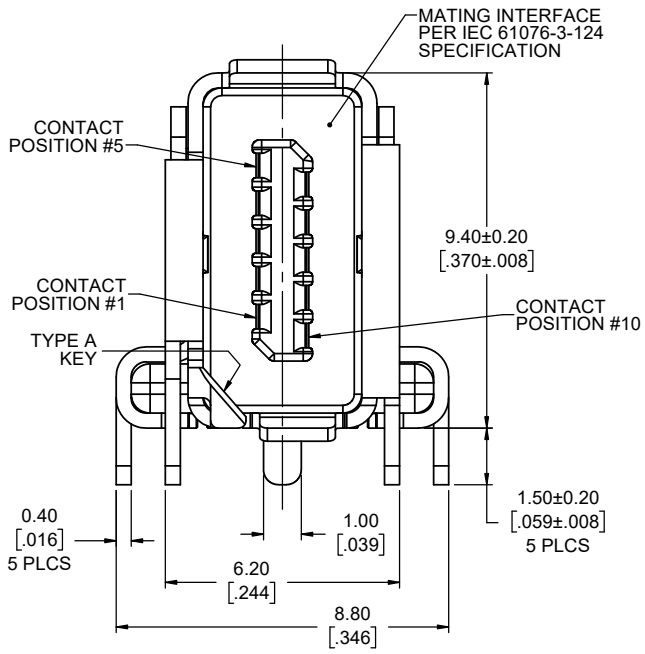
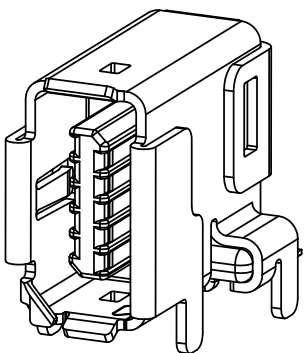
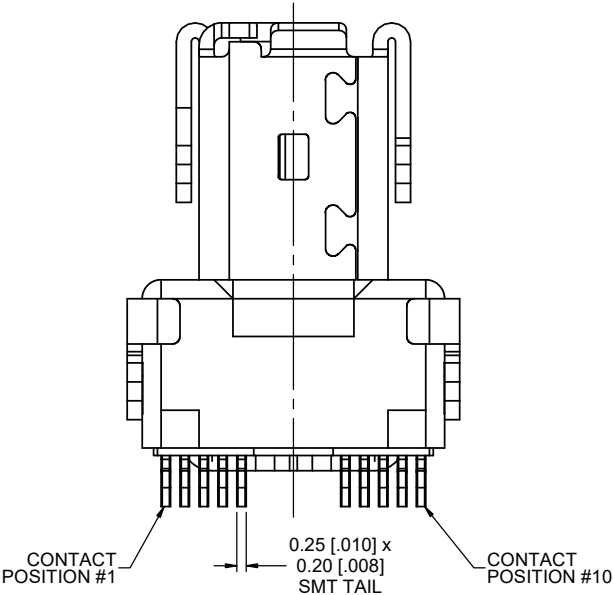

NOTES:

1. MATERIAL: RoHS COMPLIANT PER EU DIRECTIVE 2011/65/EU AND AMENDMENTS.
 - SHIELD: STAINLESS STEEL, MATTE TIN OVER NICKEL PLATED.
 - INSERTS: HIGH TEMPERATURE RESISTANT ENGINEERING THERMOPLASTIC, GLASS REINFORCED, UL94V-0, GRAY.
 - CONTACTS: COPPER ALLOY PLATED WITH GOLD OR PALLADIUM-NICKEL (SEE ORDERING CODE) OVER 1.27µm (50µ") MINIMUM NICKEL ON THE MATING AREA AND GOLD FLASH ON THE SMT TAILS.
2. CONNECTORS ARE PROVIDED IN TAPE & REEL PACKAGING FOR PICK & PLACE PROCESSING AND ARE SUITABLE FOR IR REFLOW SOLDERING OF PIN IN PASTE SHIELD TAILS AND SURFACE MOUNT CONTACT TAILS.
3. DESIGNED TO CONFORM TO REQUIREMENTS OF IEC 61076 PART 3-124 SPECIFICATION. THE TYPE A KEY FEATURE SHOWN IS INTENDED FOR USE WITH ETHERNET APPLICATIONS, EITHER 10/100 Mbit/S OR 1 TO 10 Gbit/S (CAT 5e, 6 & 6A).
4. CURRENT RATING: 1.5 AMPERES, VOLTAGE RATING: 50V AC rms OR 60V DC
5. OPERATING TEMPERATURE -55° TO +85°C.
6. DIELECTRIC WITHSTANDING VOLTAGE: 500V DC
7. CONTACT RESISTANCE: 30 MILLIOHMS MAXIMUM.
8. INSULATION RESISTANCE: 500 MEGOHMS MINIMUM.
9. MATING & UNMATING FORCE: 25N (5.6 lbf) MAXIMUM.



UNLESS SPECIFIED OTHERWISE	DRAWN	B.COPPING	MAR5/19
PRIMARY UNITS MILLIMETERS	CHECKED	K.LAMBIE	MAR5/19
SECONDARY UNITS INCHES	M.E. APP'D		
REFERENCE IN PARENTHESES	Q.A. APP'D		
GENERAL TOLERANCES	DWG APPR.		
1 DECIMAL PLACE	ENG. REL. NO.	EAR 14720	
2 DECIMAL PLACES	REF.		
3 DECIMAL PLACES	THIRD ANGLE PROJECTION		
ANGULAR DEGREES	DO NOT SCALE DRAWING		

Amphenol Canada Corp.
Commercial Products

IX INDUSTRIAL CONNECTOR, 10 POSITION TYPE A RIGHT ANGLE FLAG STYLE, SMT TERMINATION, CAT 6A HIGH SPEED PERFORMANCE, RoHS COMPLIANT

DWG. NO. **P-ND9-AS1X-00** REV **D**

CODE ID NO. 03554 DWG SIZE: X SCALE: 10:1 SHEET 1 OF 2

REVISIONS			
REV	DESCRIPTION, ECN, EAR NO.	DATE	APP'D
C	PRODUCT DRAWING (EAR 14804)	JUN12/20	M.P.
D	PRODUCT DRAWING (EAR 14804)	JUL24/20	M.P.

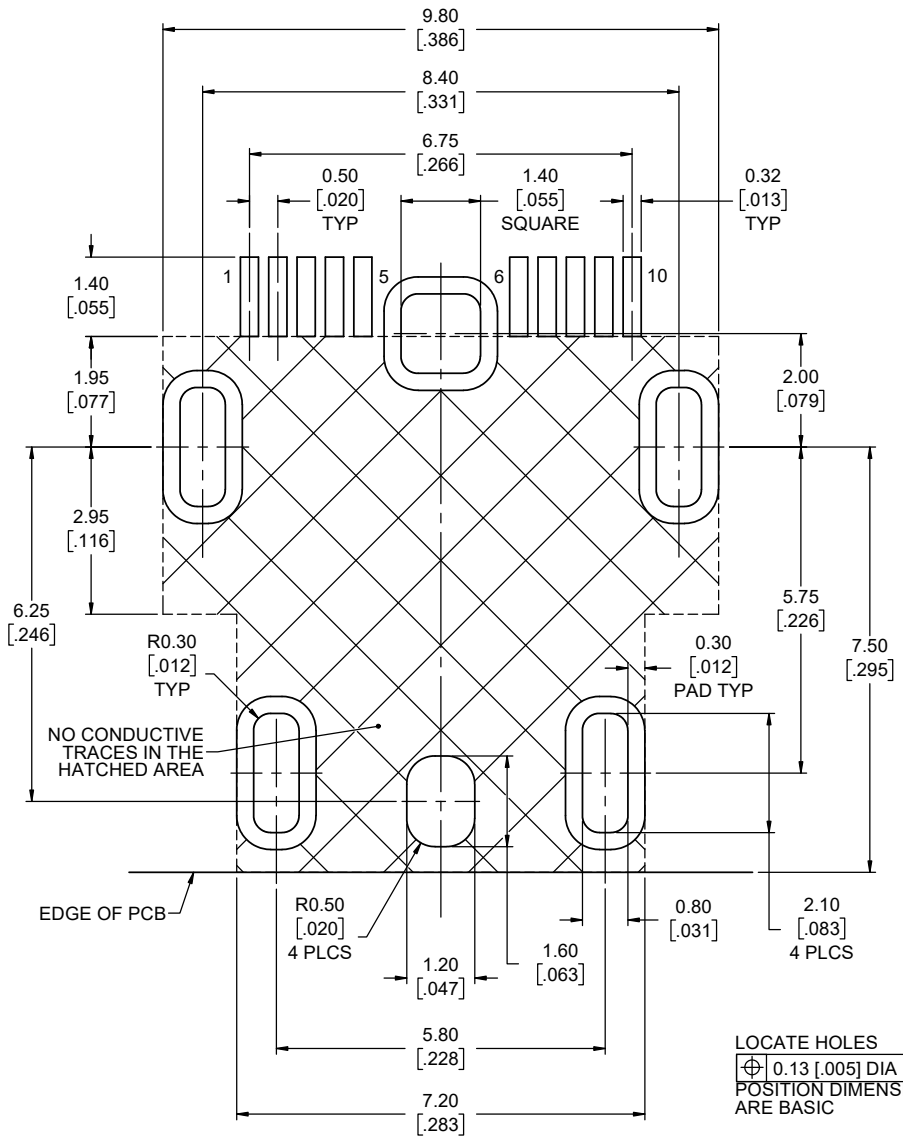

RECOMMENDED PCB LAYOUT
COMPONENT SIDE OF BOARD
SCALE 15:1
GENERAL TOLERANCE ±0.05mm
FOR THIS VIEW

LOCATE HOLES
⊕ 0.13 [.005] DIA
POSITION DIMENSIONS ARE BASIC

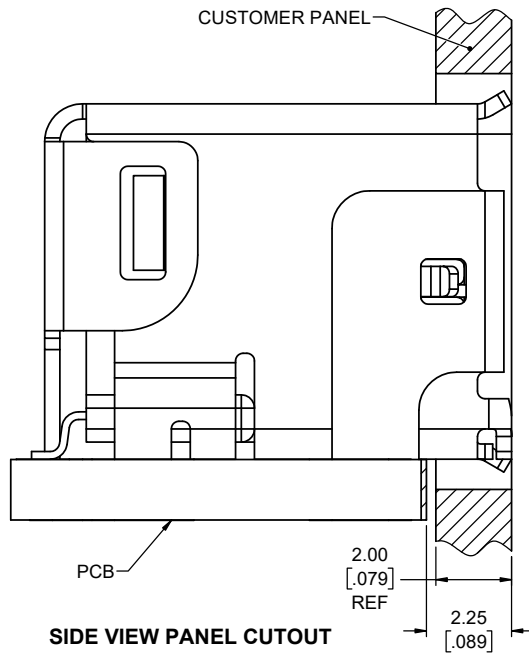

SIDE VIEW PANEL CUTOUT

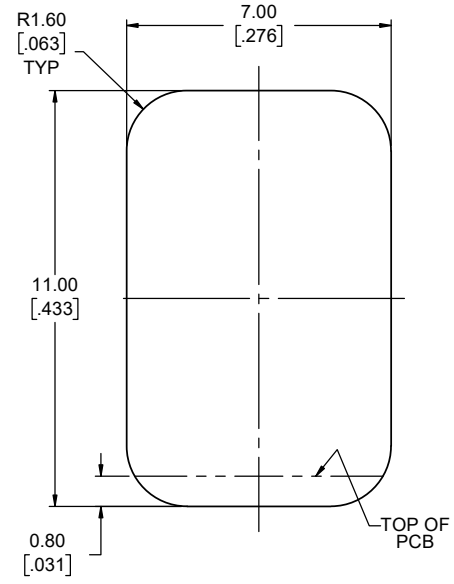

RECOMMENDED PANEL CUTOUT
OUTSIDE VIEW OF PANEL

CONNECTOR PIN ASSIGNMENT		
POSITION NUMBER	PIN ASSIGNMENT 10 OR 100 MBIT/S ETHERNET	PIN ASSIGNMENT 1, 2.5, 5 OR 10 GBIT/S ETHERNET
1	TX +	BI_DA +
2	TX -	BI_DA -
3	NOT USED	GND
4	NOT USED	BI_DC +
5	NOT USED	BI_DC -
6	RX +	BI_DB +
7	RX -	BI_DB -
8	NOT USED	GND
9	NOT USED	BI_DD +
10	NOT USED	BI_DD -



UNLESS SPECIFIED OTHERWISE	DRAWN	B.COPPING	MAR5/19
PRIMARY UNITS MILLIMETERS	CHECKED	K.LAMBIE	MAR5/19
SECONDARY INCHES	M.E. APP'D		
REFERENCE IN PARENTHESES	Q.A. APP'D		
GENERAL TOLERANCES	DWG APPR.		
1 DECIMAL PLACE	ENG. REL. NO.	EAR 14720	
2 DECIMAL PLACES	REF.		
3 DECIMAL PLACES	THIRD ANGLE PROJECTION		
ANGULAR DEGREES	DO NOT SCALE DRAWING		

Amphenol Canada Corp.
Commercial Products

IX INDUSTRIAL CONNECTOR, 10 POSITION TYPE A RIGHT ANGLE FLAG STYLE, SMT TERMINATION, CAT 6A HIGH SPEED PERFORMANCE, RoHS COMPLIANT

DWG. NO. **P-ND9-AS1X-00** REV **D**

CODE ID NO. 03554 DWG SIZE: X SCALE: 10:1 SHEET 2 OF 2