

引き出し方向
PULL OUT DIRECTION

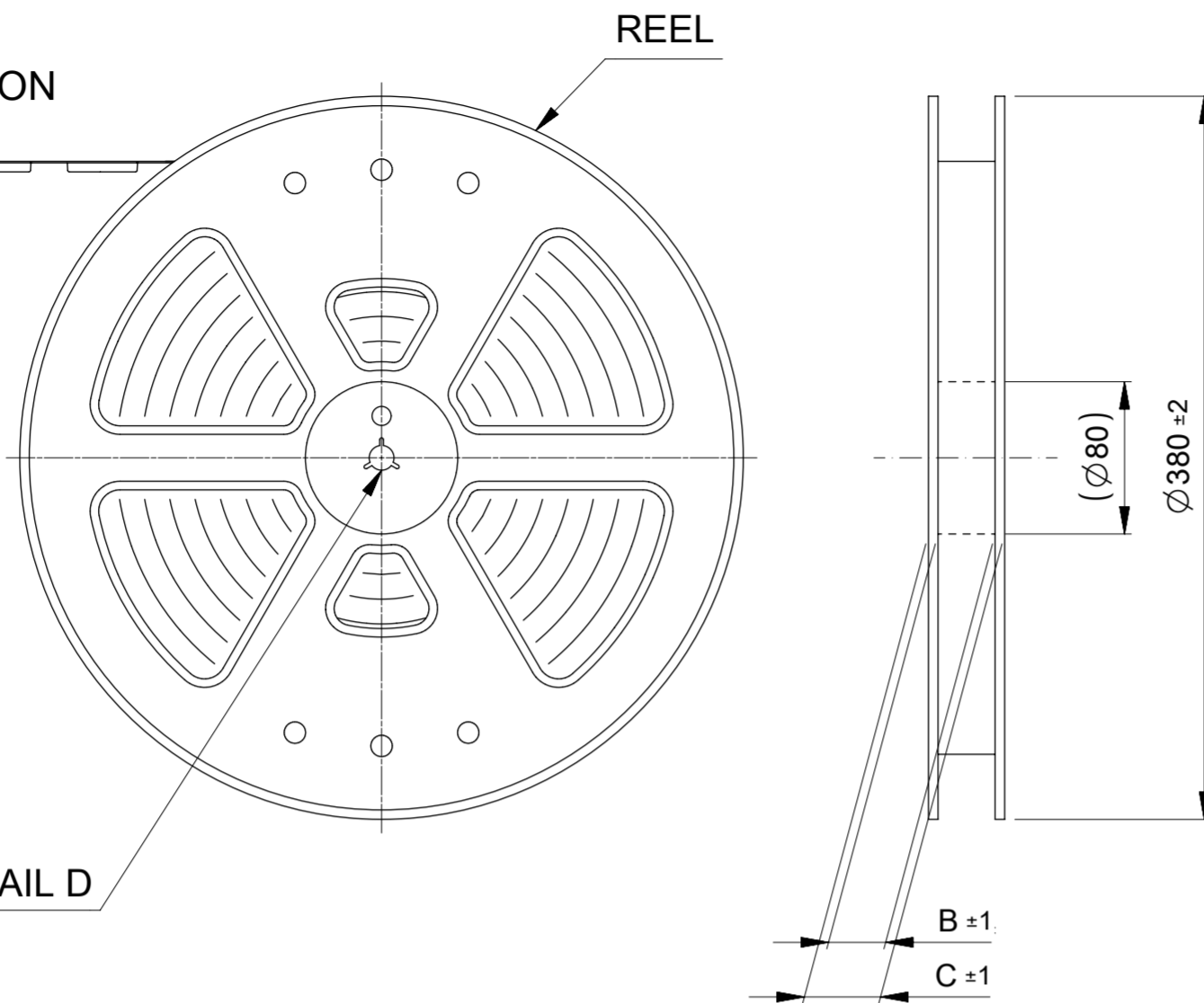

DETAIL D

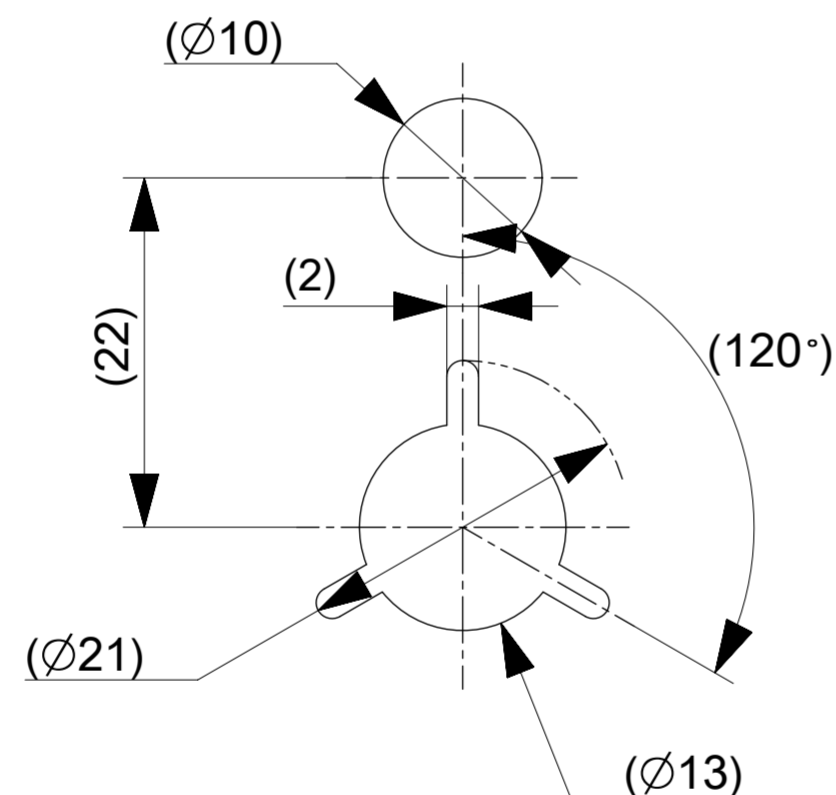

DETAIL "D"

注記 NOTES

- 製品詳細寸法については製品単体図面を参照下さい。
FOR DETAILED DIMENSION, SEE PRODUCT DRAWING.
 - 梱包数量 : 1200個/リール
THE NUMBER OF PACKAGED CONNECTORS : 1200 PCS/REEL
 - リードテープ長さ
LEAD TAPE LENGTH
-
- 材料
MATERIAL
キャリアテープ : ポリプロピレン(PP)
CARRIER TAPE : POLYPROPYLENE (PP)
トップテープ : PET, PE, PEF
TOP TAPE : PET, PE, PEF
リール : ポリスチレン(PS) <リサイクル材含む>
REEL : POLYSTYRENE (PS) <RECYCLE MATERIAL CONTAINED >
 - ELV及びRoHS適合品
ELV AND RoHS COMPLIANT.
 - トップテープの剥離強度については IEC60286-3 に準拠。
TOP TAPE PEEL FORCE IS DEFINED BY IEC60286-3.

THIS DRAWING CONTAINS INFORMATION THAT IS PROPRIETARY TO MOLEX ELECTRONIC TECHNOLOGIES, LLC AND SHOULD NOT BE USED WITHOUT WRITTEN PERMISSION									
DIMENSION UNITS mm		SCALE NTS		CURRENT REV DESC:				molex	
GENERAL TOLERANCES (UNLESS SPECIFIED)				EC NO: 656567					
ANGULAR TOL ± °				DRWN: AHMADI2		2021/02/03		0.8 MM PITCH B-TO-B CONN. PLUG (WITHOUT BOSS) EMBOSS TAPE PACKAGE	
4 PLACES ±				CHK'D: HSHIMOYAMA		2021/02/26			
3 PLACES ±				APPR: SHOSHIKAWA		2021/02/26		PRODUCT CUSTOMER DRAWING	
2 PLACES ±				INITIAL REVISION:				DOCUMENT NUMBER	
1 PLACE ±				DRWN: RMIYAMOTO		2018/07/31		533090000	
0 PLACES ±				APPR: TKUSUHARA01		2018/08/17		PSD 004 C	
DRAFT WHERE APPLICABLE MUST REMAIN WITHIN DIMENSIONS		THIRD ANGLE PROJECTION		DRAWING		SERIES		MATERIAL NUMBER	
				A2-SIZE		53309		SEE CHART	
								CUSTOMER	
								GENERAL	
								SHEET NUMBER	
								1 OF 2	

引き出し方向
PULL OUT DIRECTION

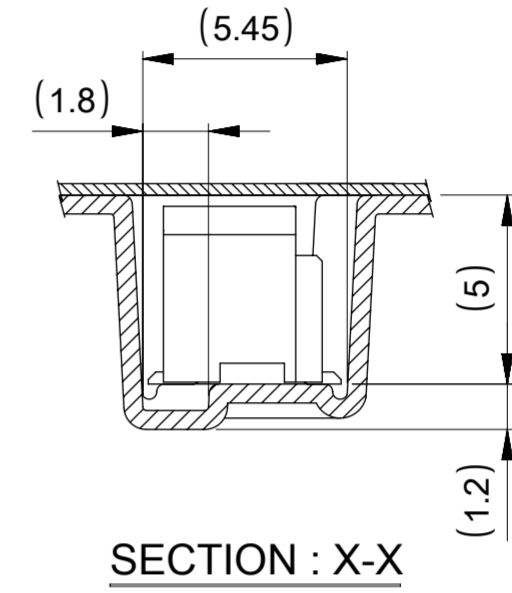
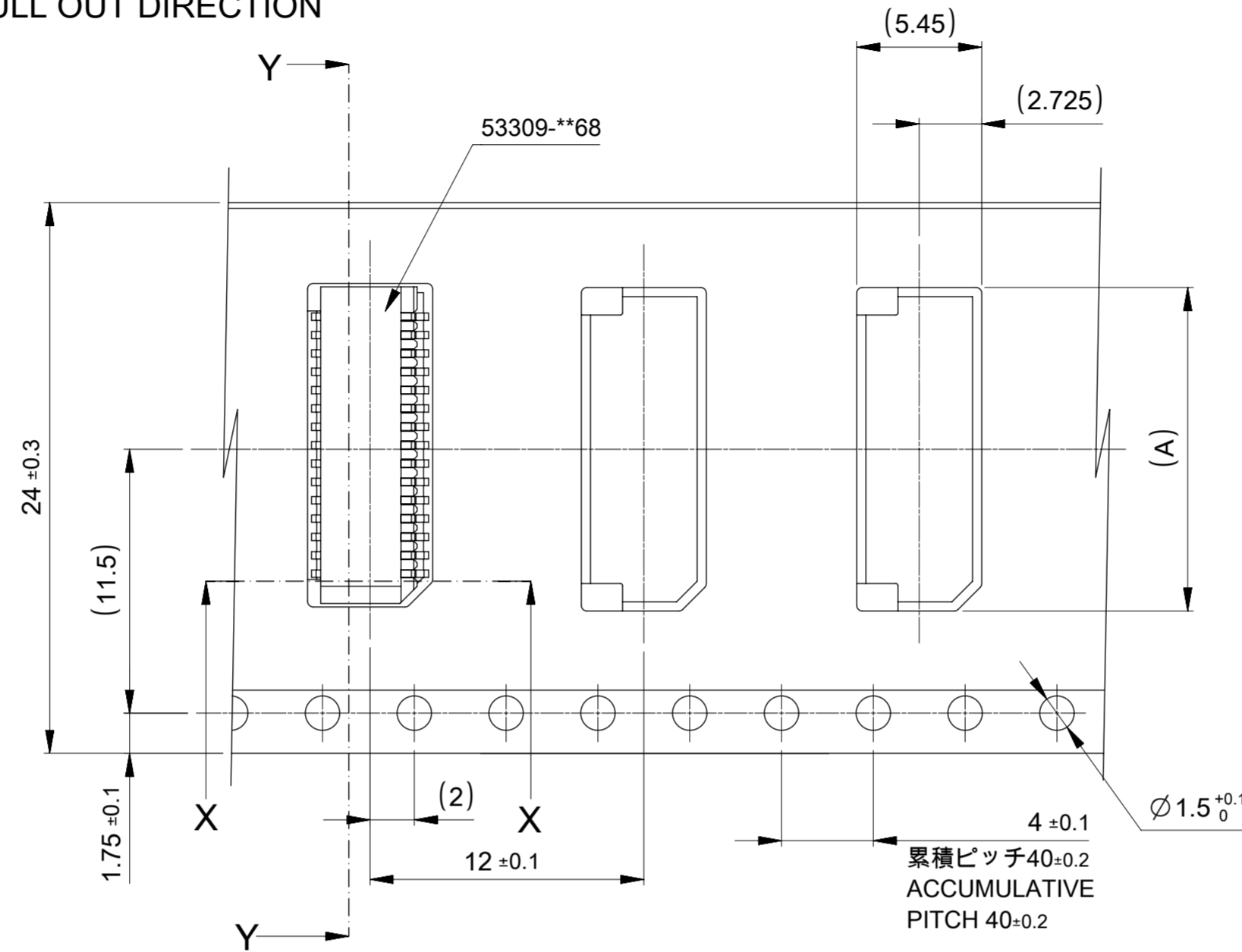
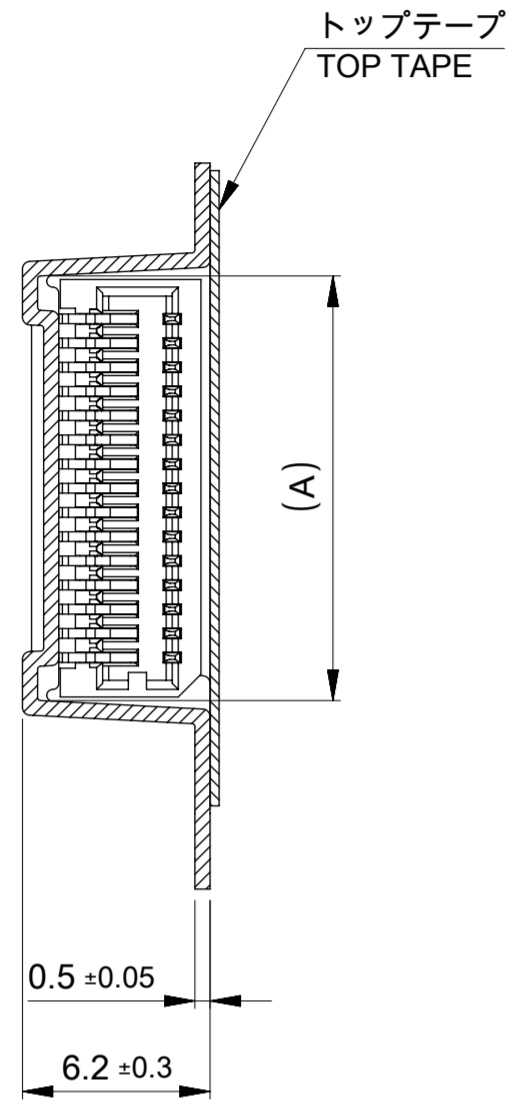

24mm幅キャリアテープ
24mm WIDTH CARRIER TAPE

24	29.4	25.4	14.9	53309-3262	32
			14.1	53309-3062	30
			10.1	53309-2062	20
キャリアテープ幅 CARRIER TAPE WIDTH	C	B	A	MATERIAL NO.	極数 CIRCUIT

THIS DRAWING CONTAINS INFORMATION THAT IS PROPRIETARY TO MOLEX ELECTRONIC TECHNOLOGIES, LLC AND SHOULD NOT BE USED WITHOUT WRITTEN PERMISSION

DIMENSION UNITS mm	SCALE NTS	CURRENT REV DESC:	molex			
GENERAL TOLERANCES (UNLESS SPECIFIED)						
ANGULAR TOL ±		EC NO: 656567	0.8 MM PITCH B-TO-B CONN. PLUG (WITHOUT BOSS) EMBOSS TAPE PACKAGE			
4 PLACES ±		DRWN: AHMADI2 2021/02/03				
3 PLACES ±		CHK'D: HSHIMOYAMA 2021/02/26	PRODUCT CUSTOMER DRAWING			
2 PLACES ±		APPR: SHOSHIKAWA 2021/02/26				
1 PLACE ±		INITIAL REVISION:	DOCUMENT NUMBER	DOC TYPE	DOC PART	REVISION
0 PLACES ±		DRWN: RMIYAMOTO 2018/07/31	533090000	PSD	004	C
		APPR: TKUSUHARA01 2018/08/17				
DRAFT WHERE APPLICABLE MUST REMAIN WITHIN DIMENSIONS	THIRD ANGLE PROJECTION	DRAWING	SERIES	MATERIAL NUMBER	CUSTOMER	SHEET NUMBER
		A2-SIZE	53309	SEE CHART	GENERAL	2 OF 2