

THIS DRAWING IS UNPUBLISHED. RELEASED FOR PUBLICATION
 © COPYRIGHT - By - ALL RIGHTS RESERVED.

| LOC | | DIST | | REVISIONS | | | |
|-----|-----|-------------|---------------|-----------|-----|------|--|
| P | LTR | DESCRIPTION | | DATE | DWN | APVD | |
| AF | 50 | D1 | ECR-15-017374 | 30NOV15 | PKS | RRP | |

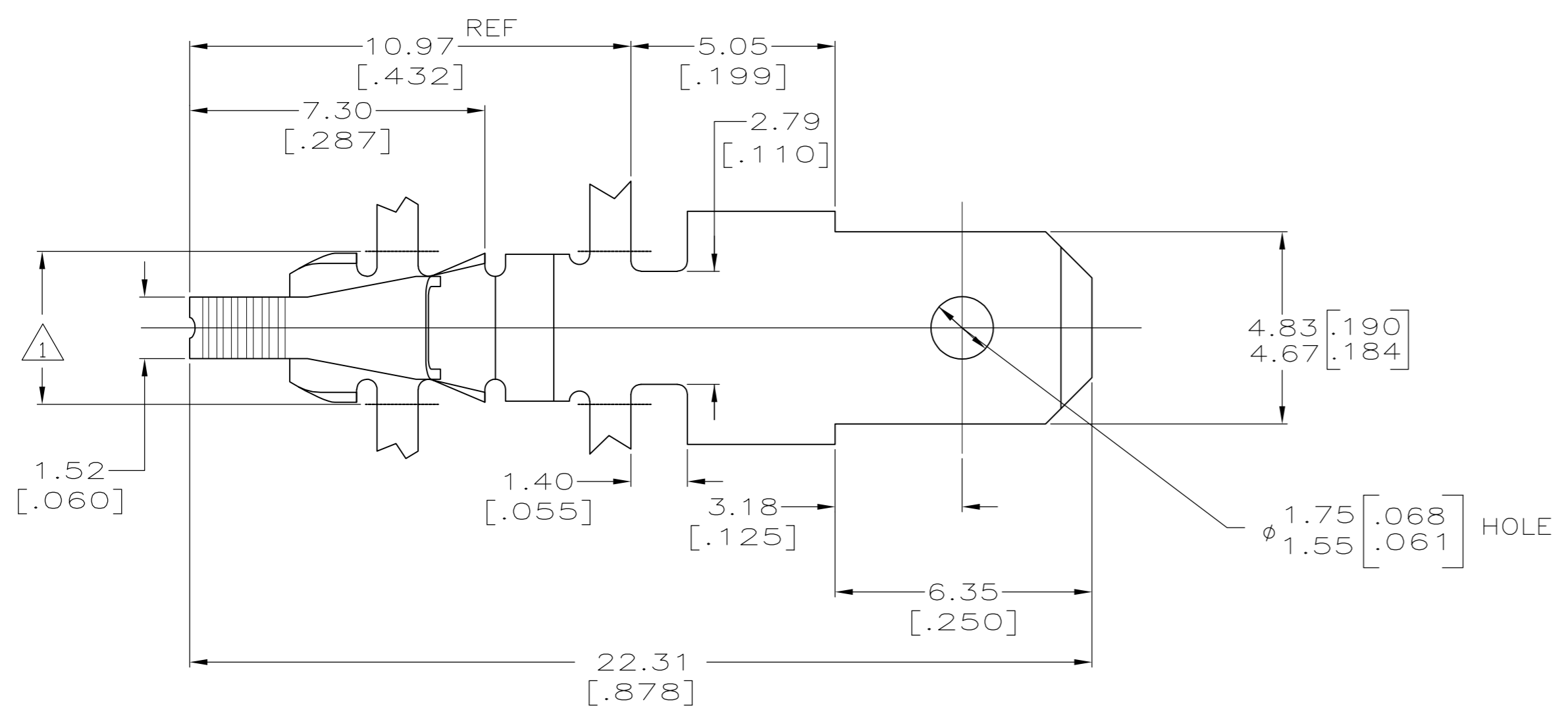

- ① 3.78±0.13 [.149±.005] APPLICATOR CUT-OFF, 2 PLACES.
- ② IDENTIFICATION NUMBER 10 FOR MAGNET WIRE RANGE.
- 3 CONTINUOUS STRIP ON REELS WITH TERMINALS LOCATED ON 8.38±0.08 [.330±.003] CENTERS
- ④ 2.72-2.97 [.107-.117] CONTACT HEIGHT WHEN COMPRESSED AGAINST ANTI-OVERSTRESS.

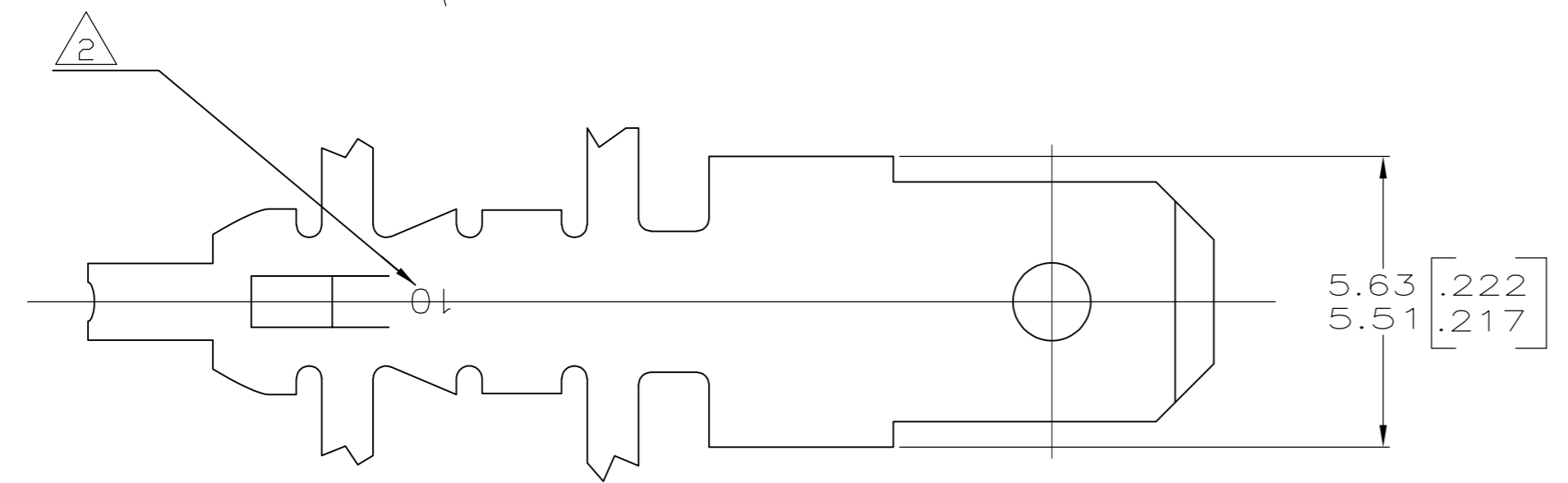
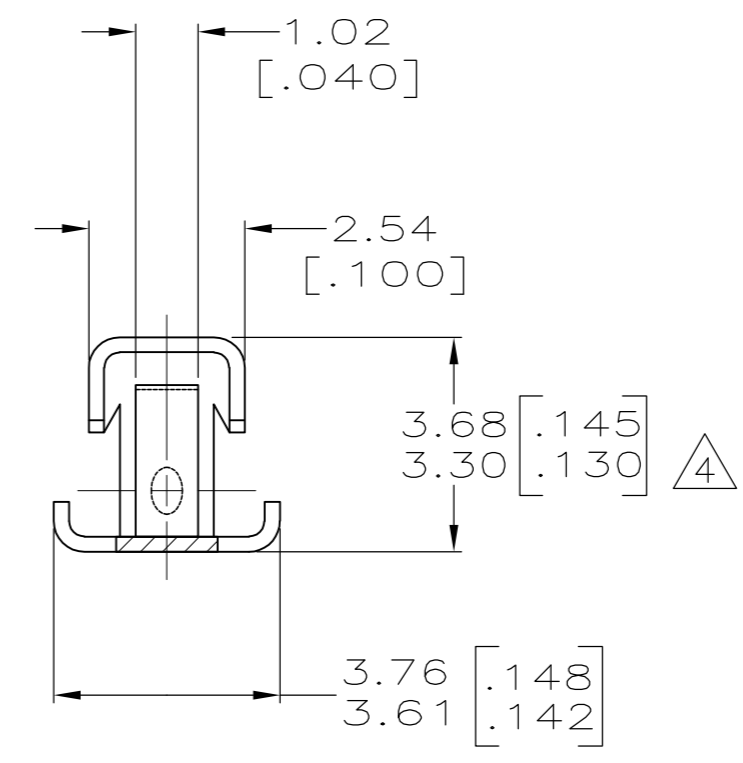
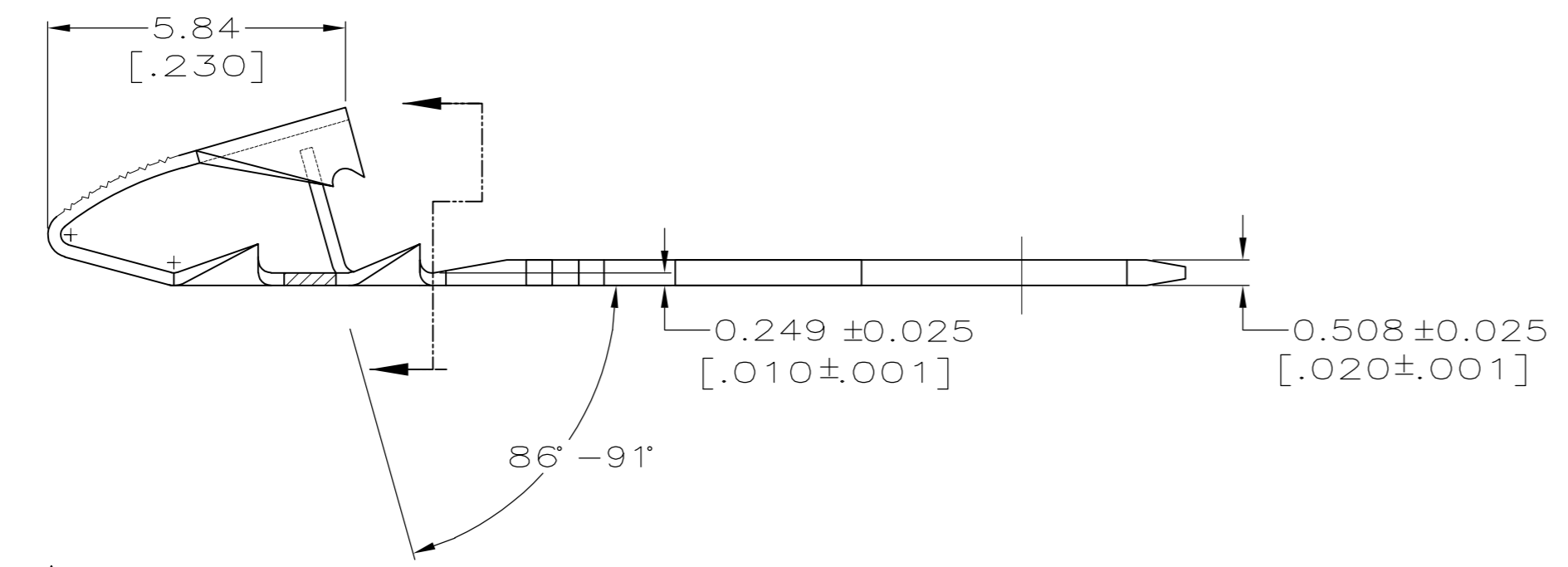

| | |
|---------------------------|-------------|
| 0.05-0.13mm [#44-#36] AWG | 1217529-1 |
| MAGNET WIRE RANGE | PART NUMBER |

| | | | | | | | | | | | | | | | | |
|--|---------------|------------------------------------|------------------------------|--------------------|-----|-------|---------------|-------|-----|-------|-----|--------|-----|--------------------------|--|--|
| THIS DRAWING IS A CONTROLLED DOCUMENT. | | DWN 10NOV2000 MICHAEL S. FEHER | | | | | | | | | | | | | | |
| DIMENSIONS: INCHES | | CHK 10NOV2000 KURT A. RANDOLPH | | | | | | | | | | | | | | |
| TOLERANCES UNLESS OTHERWISE SPECIFIED: | | APVD 10NOV2000 KURT A. RANDOLPH | NAME | | | | | | | | | | | | | |
| <table border="1"> <tr><td>0 PLC</td><td>± -</td></tr> <tr><td>1 PLC</td><td>± -</td></tr> <tr><td>2 PLC</td><td>± 0.25 [.010]</td></tr> <tr><td>3 PLC</td><td>± -</td></tr> <tr><td>4 PLC</td><td>± -</td></tr> <tr><td>ANGLES</td><td>± -</td></tr> </table> | | 0 PLC | ± - | 1 PLC | ± - | 2 PLC | ± 0.25 [.010] | 3 PLC | ± - | 4 PLC | ± - | ANGLES | ± - | PRODUCT SPEC 108-2016 | TAB, 4.75 [.187] FASTON™ MINI MAG-MATE™ | |
| 0 PLC | ± - | | | | | | | | | | | | | | | |
| 1 PLC | ± - | | | | | | | | | | | | | | | |
| 2 PLC | ± 0.25 [.010] | | | | | | | | | | | | | | | |
| 3 PLC | ± - | | | | | | | | | | | | | | | |
| 4 PLC | ± - | | | | | | | | | | | | | | | |
| ANGLES | ± - | | | | | | | | | | | | | | | |
| MATERIAL H04 PRE-MILLED | | FINISH TIN PLATE | APPLICATION SPEC 114-2047 | RESTRICTED TO | | | | | | | | | | | | |
| | | WEIGHT - | SIZE A2 | CAGE CODE 00779 | | | | | | | | | | | | |
| | | CUSTOMER DRAWING | DRAWING NO C=1217529 | SCALE 8:1 | | | | | | | | | | | | |
| | | | SHEET 1 of 1 | REV D1 | | | | | | | | | | | | |

1217529