

# SF2120C

## 149.00 MHz SAW Filter

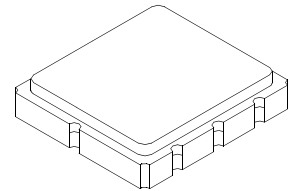

SM5050-8

- *Designed for Broadband Receiver IF Applications*
- *Low Insertion Loss*
- *5.0 X 5.0 mm Surface-mount Case*
- *Differential Input and Single-ended Output*
- *Complies with Directive 2002/95/EC (RoHS)*
- *AEC-Q200 Qualified*
- *Moisture Sensitivity Level: 1*

### Absolute Maximum Ratings

Rating	Value	Units
Maximum Incident Power in Passband	+10	dBm
Maximum DC Voltage on any Non-ground Terminal	3	VDC
Storage Temperature Range in Tape and Reel	-40 to +85	°C
Suitable for Lead-free Soldering - Maximum Soldering Profile	260 °C for 30 s	

### Electrical Characteristics

Characteristic	Sym	Min	Typ	Max	Units
Nominal Center Frequency	$f_C$		149.00		MHz
Insertion Loss			2.0	2.5	dB
2 dB Passband		148 to 150	147.65 to 150.35		MHz
Amplitude Ripple, 148 to 150 MHz, -27.5 to 72.5 °C			1.5	1.8	dB <sub>P-P</sub>
Amplitude Ripple, 148 to 150 MHz, -40 to -27.5 °C, 72.5 to 85 °C			2.0	2.2	dB <sub>P-P</sub>
Rejection, $f_C-2.5$ MHz		15	54		dB
Rejection, $f_C+2.5$ MHz		15	30		dB
Center Frequency Temperature Coefficient			-30		ppm/K
Operating Temperature		-40		85	°C
Case Style		SM5050-8 5 x 5 mm Nominal Footprint			
Lid Symbolization (Y=year, WW=week, S=shift)		635, <u>YWWS</u>			

### Electrical Connections - Differential Operation

Connection	Terminals
Port 1 Differential Input	1, 2
Port 2 Output	5
Ground	All others

Dot indicates Pin 1

### Electrical Connections - Single End Operation

Connection	Terminals
Port 1 Input	1
Port 2 Output	5
Ground	All others

Dot indicates Pin 1

 **CAUTION: Electrostatic Sensitive Device. Observe precautions for handling.**

#### NOTES:

1. The design, manufacturing process, and specifications of this device are subject to change.
2. US or International patents may apply.
3. RoHS compliant from the first date of manufacture.

2 dB BW

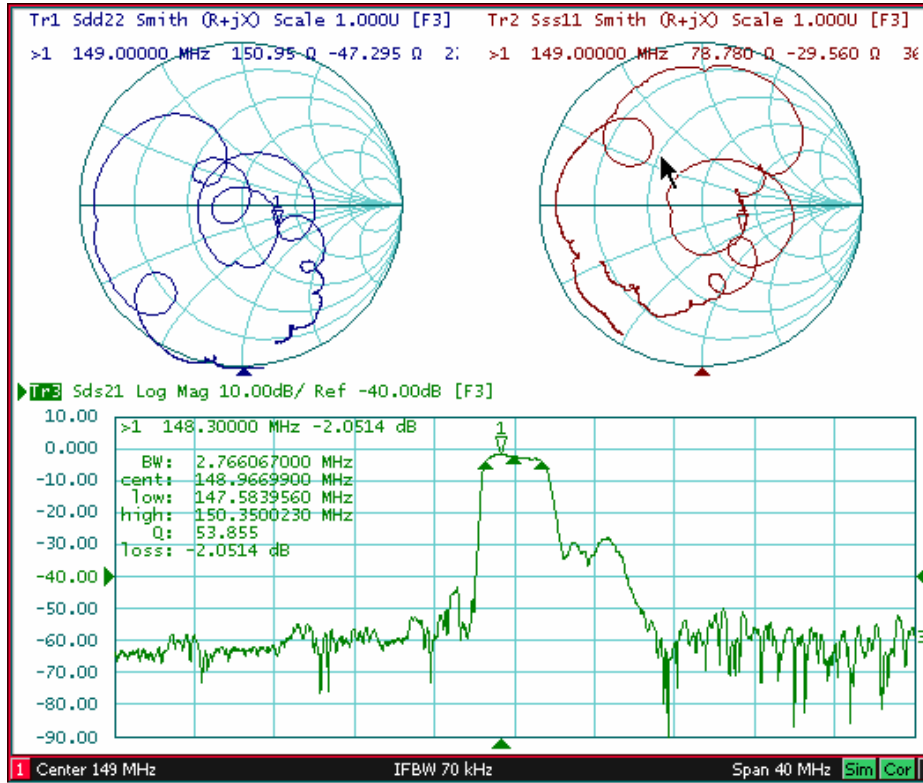

3 dB BW

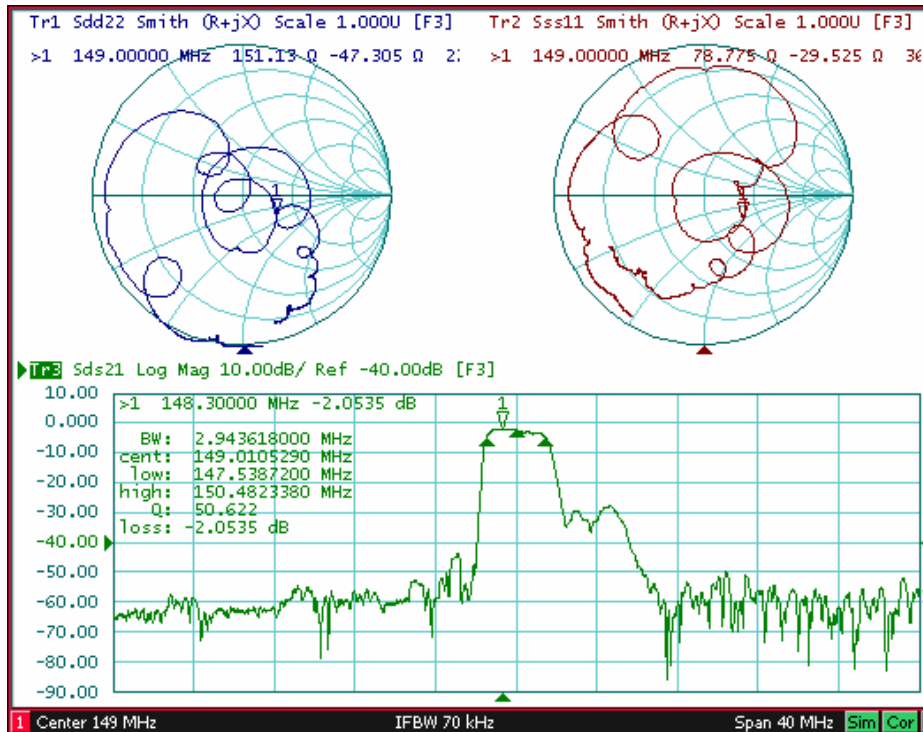

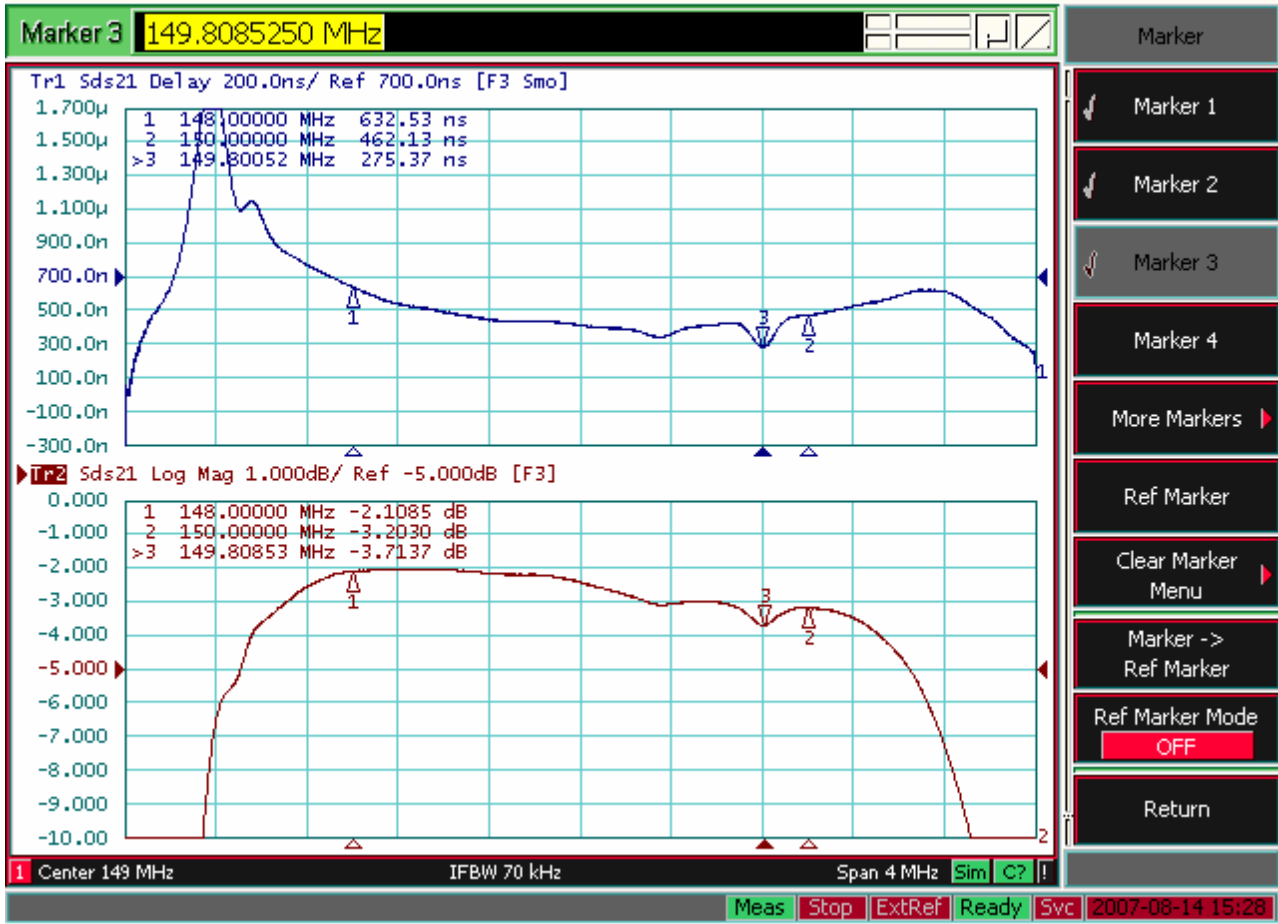

### Electrical Connections

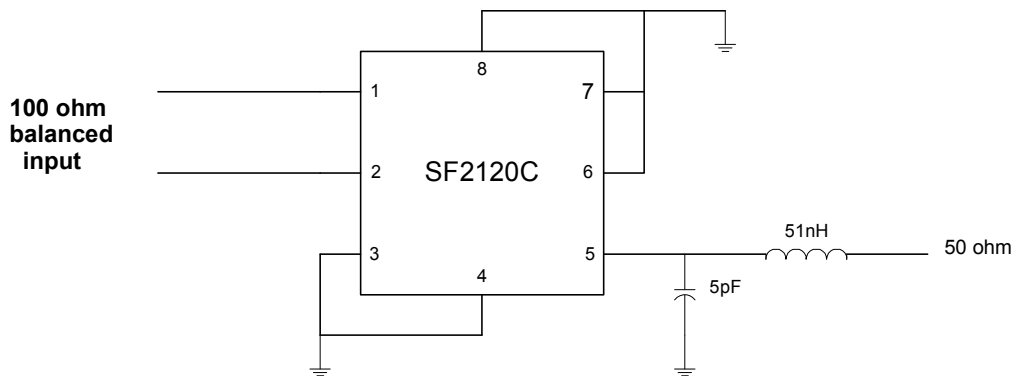

12 Jul 2007 09:02:21

CH1 S11 1 UFS  
1: 67.484 Ω -46.605 Ω 22.919 pF  
149.000 000 MHz

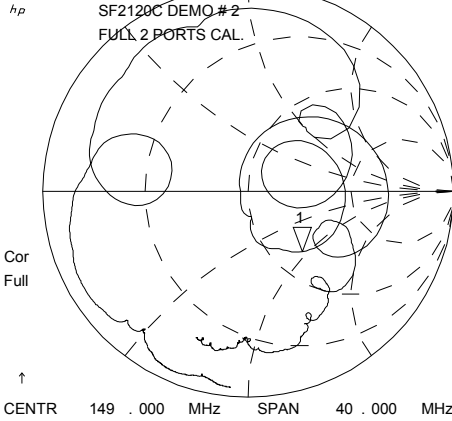

CH3 S22 1 UFS  
1: 79.445 Ω -47.031 Ω 22.712 pF  
149.000 000 MHz

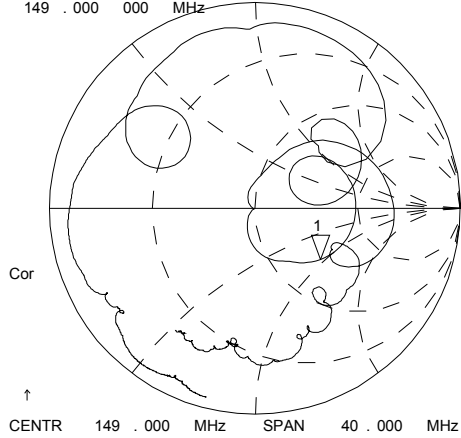

CH2 S21 LOG 10 dB/ REF -2.43 dB 1: -2.8632 dB 149.000 000 MHz

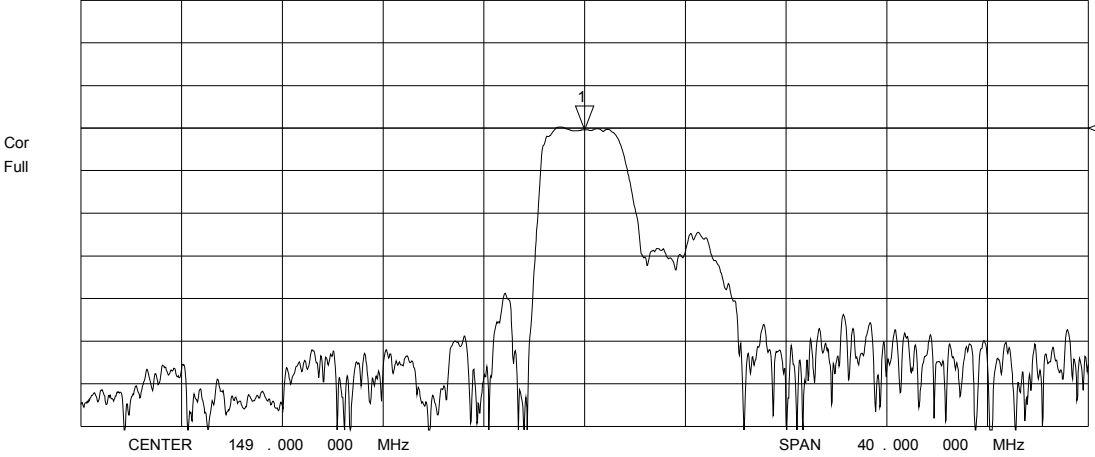

12 Jul 2007 08:52:09

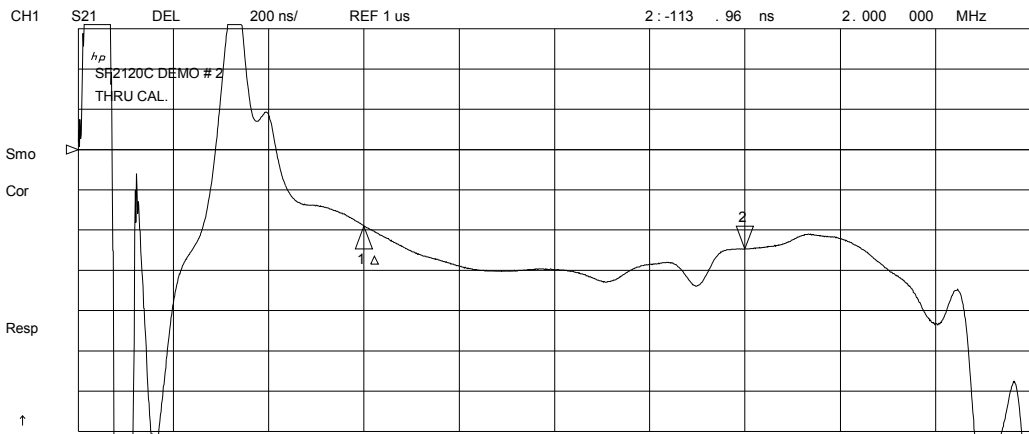

CH1 Markers  
 $\Delta$  REF=1  
 mean : 431 . 85 ns  
 s. dev : 63 . 986 ns  
 p-p : 298 . 60 ns

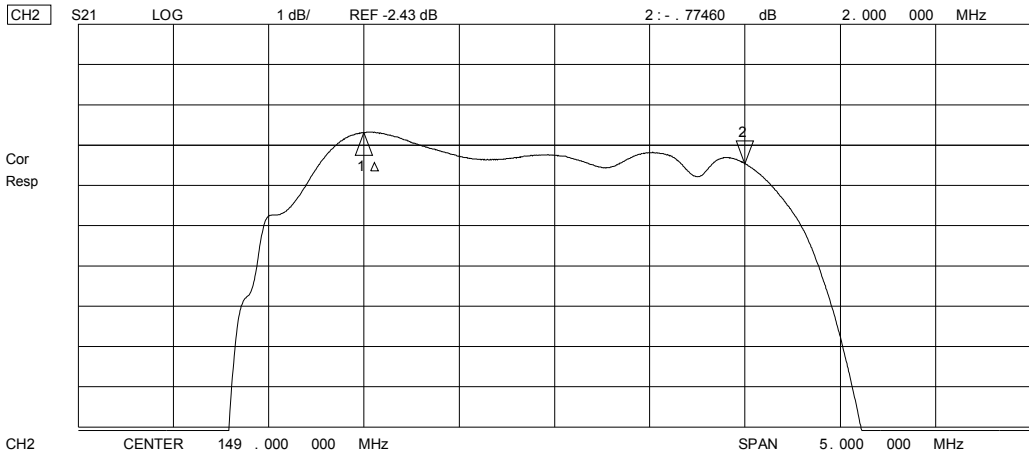

CH2 Markers  
 $\Delta$  REF=1  
 mean : -2 . 6956 dB  
 s. dev : . 24420 dB  
 p-p : 1 . 1153 dB

CH2 CENTER 149 . 000 000 MHz SPAN 5. 000 000 MHz

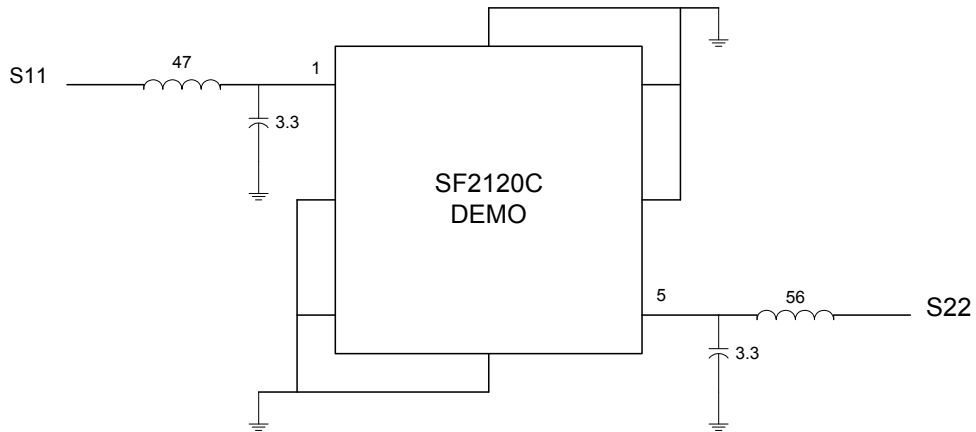

- |              |             |        |
|--------------|-------------|--------|
| 401-1624-001 |             |        |
| 501-0782-470 | 0805, 47NH  | L1     |
| 501-0782-560 | 0805, 56NH  | L2     |
| 501-0621-033 | 0603, 3.3PF | C1, C2 |

# SM5050-8 Surface-Mount 8-Terminal Ceramic Case 5.0 X 5.0 mm Nominal Footprint

## Case Dimensions

Dimension	mm			Inches		
	Min	Nom	Max	Min	Nom	Max
A	4.80	5.00	5.20	0.189	0.197	0.205
B	4.80	5.00	5.20	0.189	0.197	0.205
C	1.30	1.50	1.70	0.050	0.060	0.067
D	1.98	2.08	2.18	0.078	0.082	0.086
E	1.07	1.17	1.27	0.042	0.046	0.050
F	0.50	0.64	0.70	0.020	0.025	0.028
G	2.39	2.54	2.69	0.094	0.100	0.106
H		1.27			0.050	
I		0.76			0.030	
J		1.55			0.061	
K		2.79			0.110	
L		0.76			0.030	
M		2.36			0.093	
N		1.55			0.061	
O		2.79			0.110	
P		2.79			0.110	
Q		2.79			0.110	

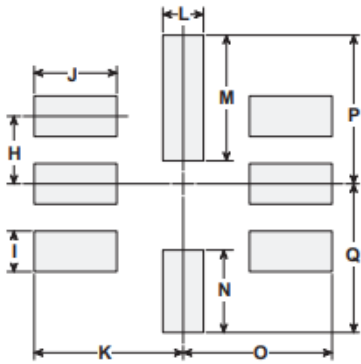
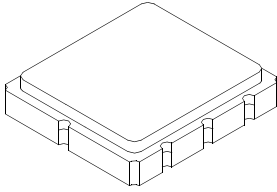

PCB Footprint

## Case Materials

Materials	
Solder Pad Plating	0.3 to 1.0 $\mu$ m Gold over 1.27 to 8.89 $\mu$ m Nickel
Lid Plating	2.0 to 3.0 $\mu$ m Nickel
Body	Al <sub>2</sub> O <sub>3</sub> Ceramic

TOP VIEW

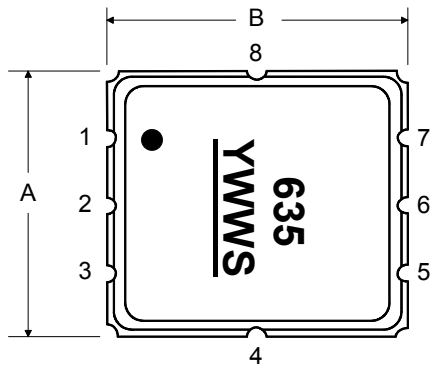

BOTTOM VIEW

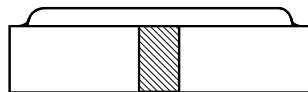
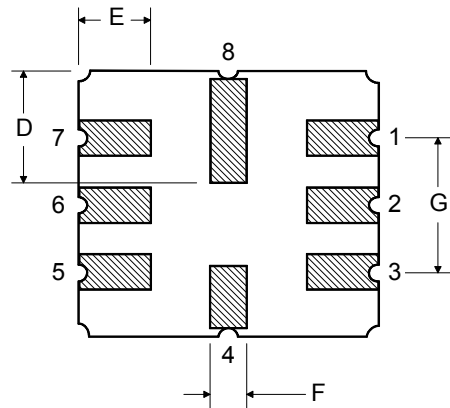

## Tape and Reel Specifications

Tape and Reel Standard per ANSI/EIA-481

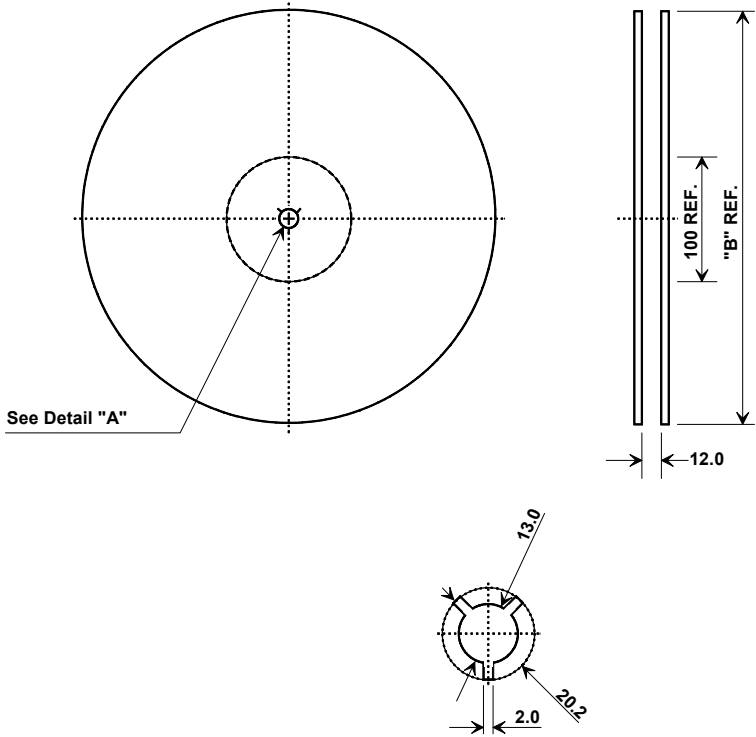

"B" Nominal Size		Quantity Per Reel
Inches	millimeters	
7	178	500
13	330	3000

### COMPONENT ORIENTATION and DIMENSIONS

Carrier Tape Dimensions	
Ao	5.3 mm
Bo	5.3 mm
Ko	2.0 mm
Pitch	8.0 mm
W	12.0 mm

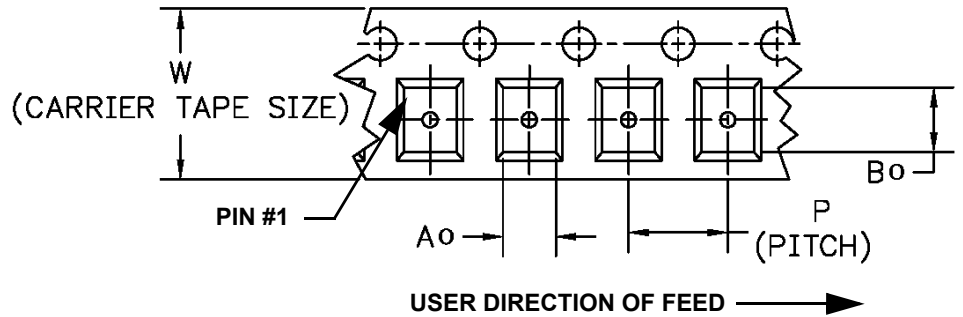
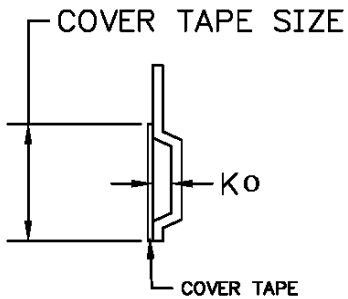

## Recommended Reflow Profile

1. Preheating shall be fixed at 150~180°C for 60~90 seconds.
2. Ascending time to preheating temperature 150°C shall be 30 seconds min.
3. Heating shall be fixed at 220°C for 50~80 seconds and at 260°C+0/-5°C peak (10 seconds).
4. Time: 5 times maximum.

