

REVISIONS					
P	LTR	DESCRIPTION	DATE	DWN	APVD
D2		REVISED PER ECN-22-141944	04MAR2022	RZ	WK

NOTES

- 1 SINGLE PACK IN ACCORDANCE WITH AMP SPEC 107-3275
- 2 100 BODIES IN A HEAT SEALED BAG; 100 CONTACTS IN SEPARATE HEAT SEALED BAG; 100 CRIMP SLEEVES IN A SEPARATE HEAT SEALED BAG. ALL THREE BAGS WOULD BE PLACED IN A LABELED UNIT CONTAINER TO MAKE A PACKAGE OF 100 COMPLETE KITS.
- 3 Au PLATING OVER Ni PLATING OVER Cu PLATING
- 4 Ni PLATING OVER Cu PLATING
- 5. HAND TOOL: 9-1478240-0
- 6. DIE SET: 9-1478242-0
- 7. FOR TECHNICAL DATA REFER TO YOUR LOCAL TE CONNECTIVITY SALES OFFICE
- 8. ALL DIMENSIONS ARE NOMINAL FOR REFERENCE ONLY UNLESS OTHERWISE STATED

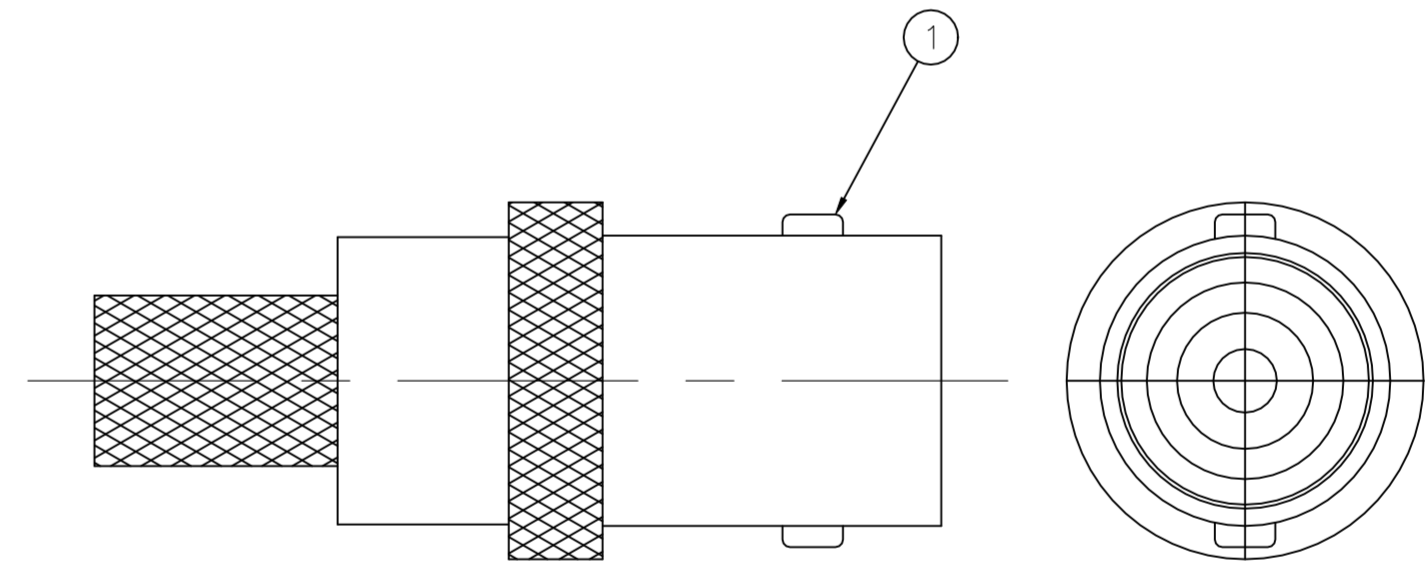
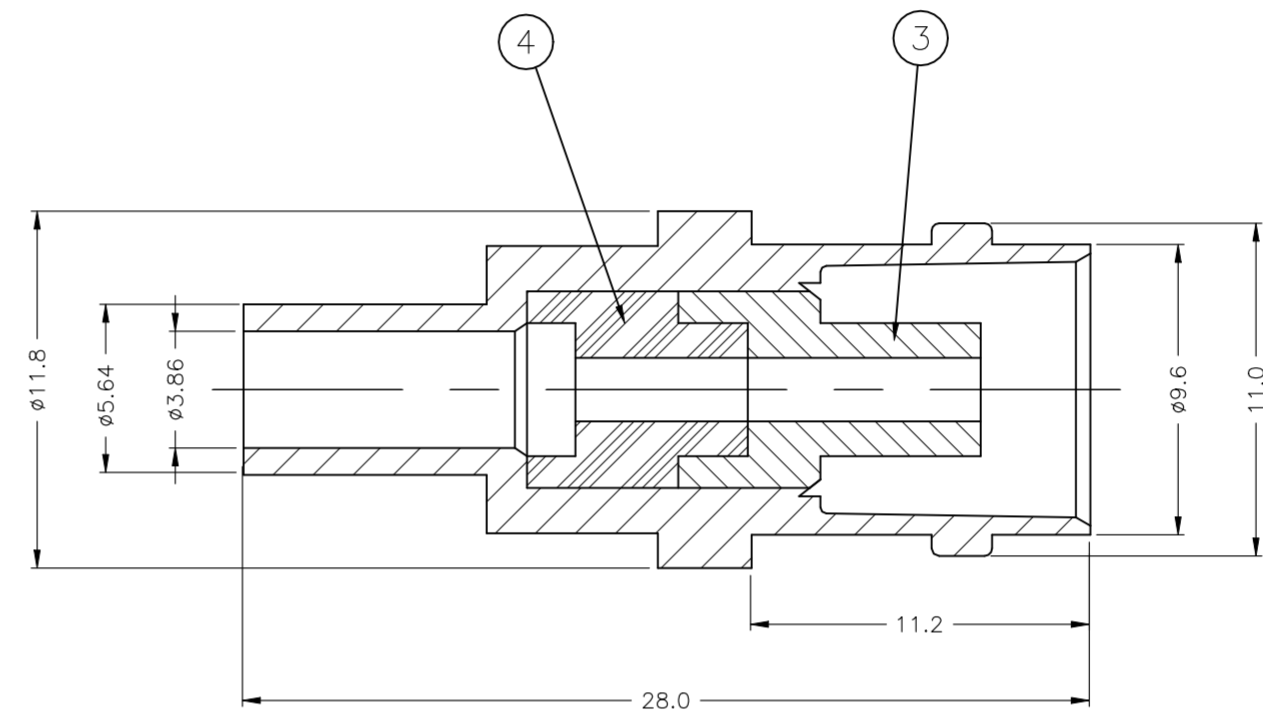
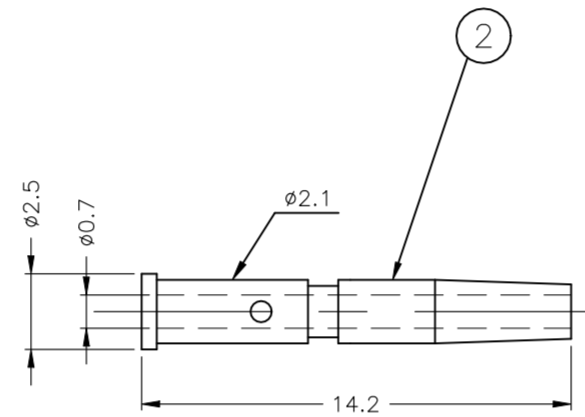
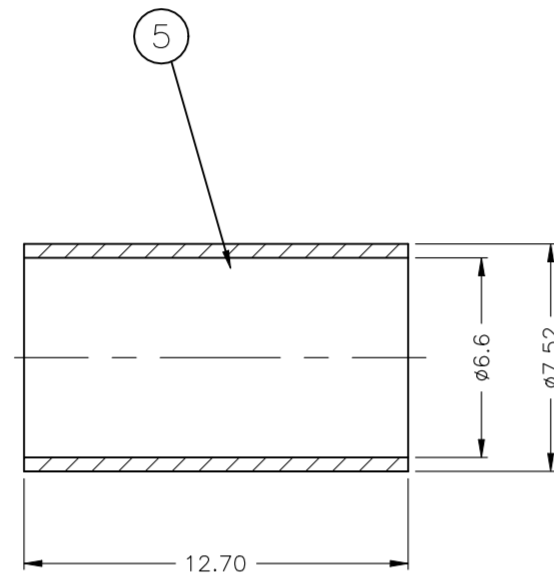

QTY	QTY PER ASSY	PARTS LIST	DESCRIPTION	ITEM
1	1	BRASS	CRIMP SLEEVE	5
1	1	POLYMETHYLPENTENE	INSULATOR	4
1	1	POLYMETHYLPENTENE	INSULATOR	3
1	1	PHOSPHOR BRONZE	CONTACT	2
1	1	ZINC ALLOY	BODY	1
5	15	MATERIAL	DESCRIPTION	ITEM

THIS DRAWING IS A CONTROLLED DOCUMENT.

DWN	RITA ZUO	11 Mar 09
CHK	ANSON MA	11 Mar 09
APVD	BOB ZHAO	11 Mar 09
PRODUCT SPEC	108-112000	
APPLICATION SPEC	SEE SHEET 2	
WEIGHT	-	
CUSTOMER DRAWING		

TE TE Connectivity



BNC STRAIGHT JACK CRIMP 75 OHM
RG59B/U, 62A/U, 140/U, 210/U, URM90

SIZE	A2	CAGE CODE	00779	DRAWING NO	C=1634514	RESTRICTED TO	-
SCALE	NTS	SHEET	1 OF 2	REV	D2		

REVISIONS

P	LTR	DESCRIPTION	DATE	DWN	APVD
-	-	SEE SHEET 1	-	-	-

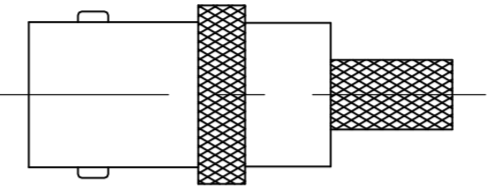
COMPONENTS

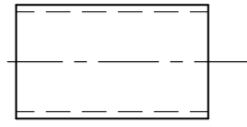
			MAIN BODY (ITEM 1,3, & 4)	CONTACT (ITEM 2)	CRIMP FERRULES (ITEM 5)	
D						D

ASSEMBLY INSTRUCTION

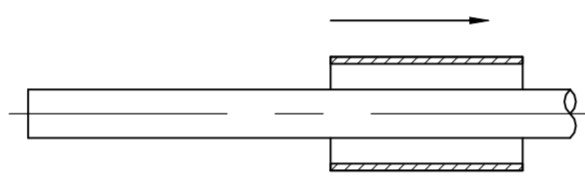
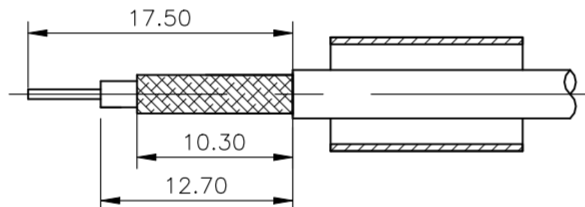
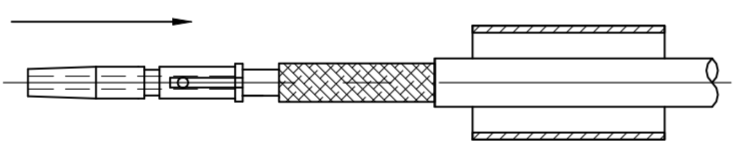
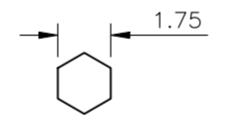
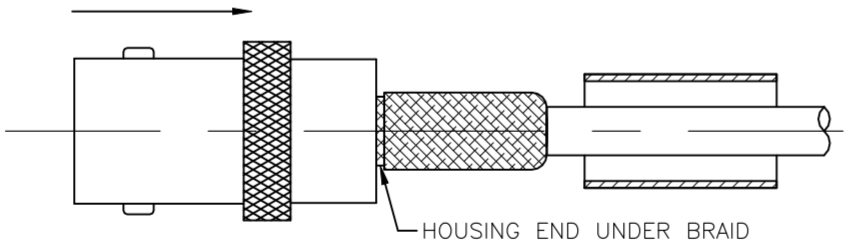
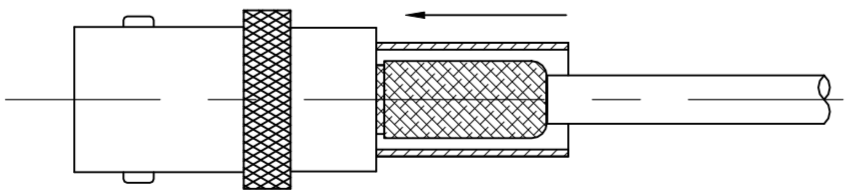
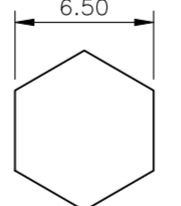
CABLES: RG59B/U, 62A/U, 140/U, 210/U, URM90 KX6A, KX25, KX52, KX53	
<p>STEP 1</p> <p>1. SLIDE METAL CRIMP FERRULE OVER CABLE</p> 	
<p>STEP 2</p> <p>1. STRIP CABLE TO DIMENSIONS AS SHOWN</p> 	
<p>STEP 3</p> <p>1. FIT CONTACT OVER CENTRE CONDUCTOR TO BUTT AGAINST DIELECTRIC. 2. CRIMP USING TOOL AS NOTES ON PAGE 1.</p>  <p>RECOMMENDED CENTRE CONTACT A/F HEX</p> 	
<p>STEP 4</p> <p>1. PRESS SUB-ASSEMBLY INTO BODY, UNTIL CONTACT IS FULLY LOCATED BY AN AUDIBLE CLICK. 2. ENSURE THAT KNURLED HOUSING INSERTS BETWEEN THE DIELECTRIC AND CABLE BRAID.</p>  <p>HOUSING END UNDER BRAID</p>	
<p>STEP 5</p> <p>1. SLIDE CRIMP FERRULE ALONG THE CABLE UNTIL IT BUTTS AGAINST THE HOUSING BODY. 2. CRIMP USING TOOL AS NOTED ON PAGE 1. 3. CRIMP DIMENSION AS SHOWN.</p>  <p>RECOMMENDED CRIMP SLEEVE A/F HEX</p> 	

THIS DRAWING IS A CONTROLLED DOCUMENT.		DWN RITA ZUO 11 Mar 09	 TE Connectivity															
DIMENSIONS: mm		CHK ANSON MA 11 Mar 09																
TOLERANCES UNLESS OTHERWISE SPECIFIED:		APVD BOB ZHAO 11 Mar 09	NAME BNC STRAIGHT JACK CRIMP 75 OHM RG59B/U, 62A/U, 140/U, 210/U, URM90															
<table border="1"> <tr><td>0 PLC</td><td>± 0.5</td></tr> <tr><td>1 PLC</td><td>± 0.3</td></tr> <tr><td>2 PLC</td><td>± 0.2</td></tr> <tr><td>3 PLC</td><td>± -</td></tr> <tr><td>4 PLC</td><td>± -</td></tr> <tr><td>ANGLES</td><td>± -</td></tr> <tr><td>FINISH</td><td>-</td></tr> </table>		0 PLC	± 0.5	1 PLC	± 0.3	2 PLC	± 0.2	3 PLC	± -	4 PLC	± -	ANGLES	± -	FINISH	-	PRODUCT SPEC 108-112000	RESTRICTED TO -	
0 PLC	± 0.5																	
1 PLC	± 0.3																	
2 PLC	± 0.2																	
3 PLC	± -																	
4 PLC	± -																	
ANGLES	± -																	
FINISH	-																	
MATERIAL		APPLICATION SPEC SEE SHEET 2	SIZE A2	CAGE CODE 00779														
		WEIGHT -	DRAWING NO C=1634514															
		CUSTOMER DRAWING		SCALE NTS														
		SHEET 2 OF 2		REV D2														