

## Network cable - VS-M12FSBPS-IP20-93E-LI/5,0 - 1404208

Please be informed that the data shown in this PDF Document is generated from our Online Catalog. Please find the complete data in the user's documentation. Our General Terms of Use for Downloads are valid (<http://phoenixcontact.com/download>)



Assembled Ethernet cable, CAT5e, shielded, 2-pair, 26 AWG stranded (7-wire), RAL 5021 (water blue), M12 flush-type socket, rear/screw mounting with SPEEDCON to RJ45 plug/IP20, line, length 5 m

RoHS

### Key Commercial Data

Packing unit	1 pc
GTIN	 4 046356 681506
GTIN	4046356681506

### Technical data

#### Ambient conditions

Ambient temperature (operation)	-25 °C ... 60 °C (cable, fixed installation)
	-5 °C ... 60 °C (cable, flexible installation)

#### General data

Number of positions	4
Alternative short product description	Ethernet cable

#### Cable

Cable type	Ethernet
Cable type (abbreviation)	93E
Signal type/category	Ethernet CAT5 (IEC 11801:2002)
Cable structure	2x2xAWG26/7 PIMF
Conductor cross section	2x 2x 0.14 mm <sup>2</sup>
AWG signal line	26
Conductor structure signal line	7x 0.15 mm
Core diameter including insulation	≤ 1.05 mm
Wire colors	white/orange-orange, white/green-green
Twisted pairs	2 cores to the pair
Type of pair shielding	Aluminum-lined polyester foil

## Network cable - VS-M12FSBPS-IP20-93E-LI/5,0 - 1404208

### Technical data

#### Cable

Overall twist	Two pairs with two fillers to the core
Shielding	Tinned copper braided shield
External sheath, color	water blue RAL 5021
External cable diameter D	6.7 mm
Smallest bending radius, movable installation	34 mm
Tensile strength GRP	30 N (for installation)
	10 N (in accordance with installation)
Cable weight	42 kg/km
Outer sheath, material	PUR
Material conductor insulation	Cell PE
Conductor material	Bare Cu litz wires
Insulation resistance	≥ 5 GΩ*km
Conductor resistance	≤ 150 Ω/km
Working capacitance	42 pF
Wave impedance	100 Ω ±5 % (at 100 MHz)
Signal speed	0.72 c
Shield attenuation	60 dB (up to 1000 MHz)
Coupling resistance	5.00 mΩ/m (at 10 MHz)
Nominal voltage, cable	max. 125 V
Test voltage, cable	1000 V
Special properties	Free of substances which would hinder coating with paint or varnish
Flame resistance	complying with IEC 60332-2-2
Halogen-free	complying with IEC 60754-1/2
Resistance to oil	in accordance with DIN EN 60811-2-1
Other resistance	Microbe resistance as per VDE 0282 section 10
	Hydrolysis resistance as per DIN 53504
Concentration of fumes	in accordance with IEC 61034-1/2
Ambient temperature (operation)	-40 °C ... 70 °C (cable, fixed installation)
	-10 °C ... 50 °C (cable, flexible installation)

#### Environmental Product Compliance

	Lead 7439-92-1
China RoHS	Environmentally Friendly Use Period = 50
	For details about hazardous substances go to tab "Downloads", Category "Manufacturer's declaration"

#### Drawings

# Network cable - VS-M12FSBPS-IP20-93E-LI/5,0 - 1404208

Dimensional drawing

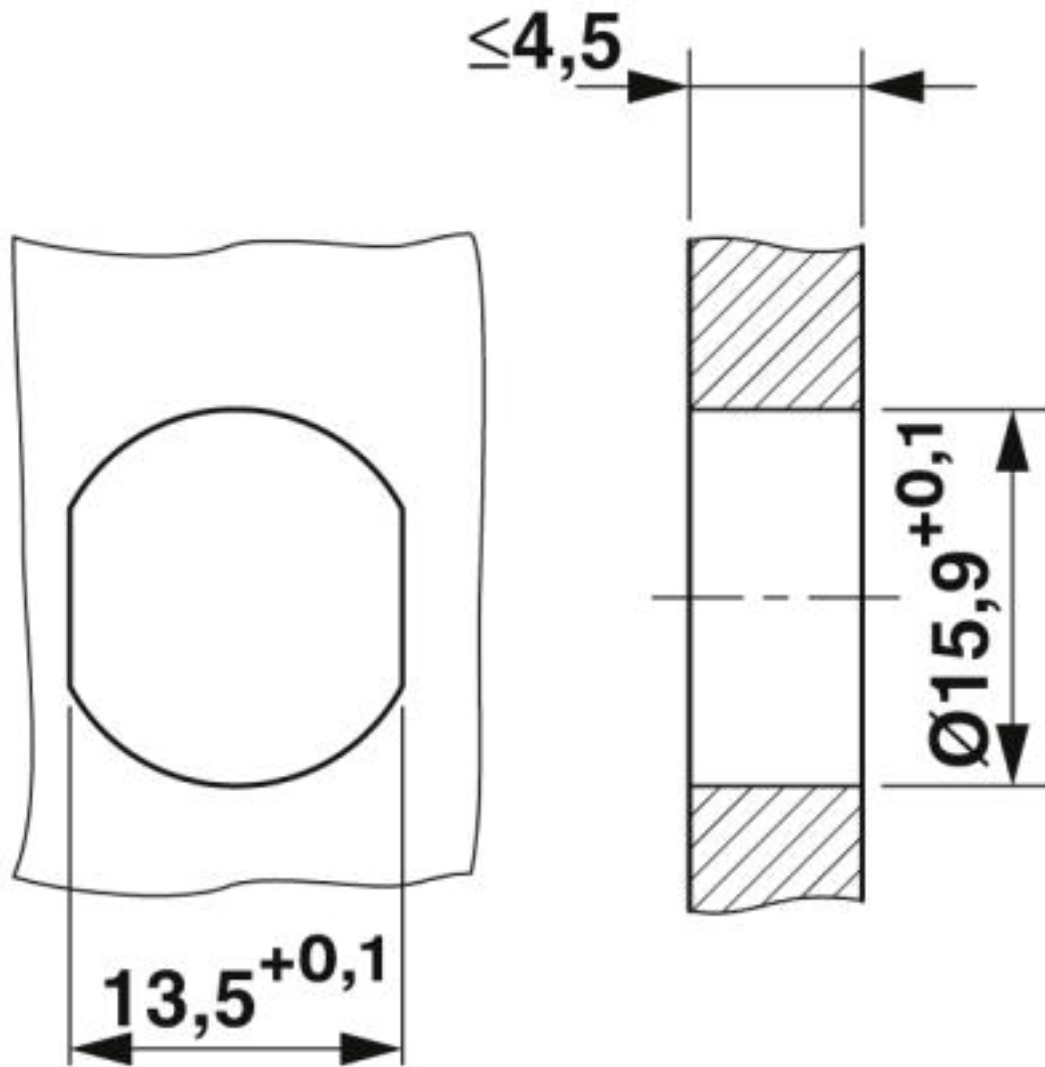

Housing cutout for M16 fastening thread, mounting panel with feed-through hole (alternatively with surface as protection against rotation)

# Network cable - VS-M12FSBPS-IP20-93E-LI/5,0 - 1404208

Dimensional drawing

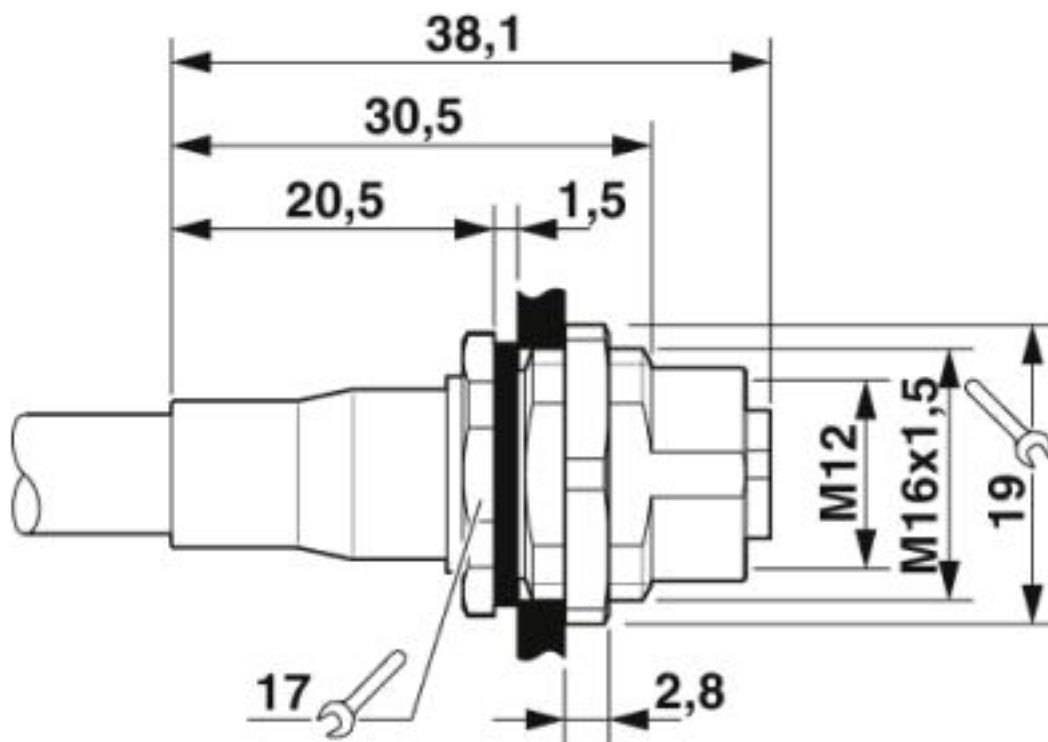

M12 flush-type connector

Dimensional drawing

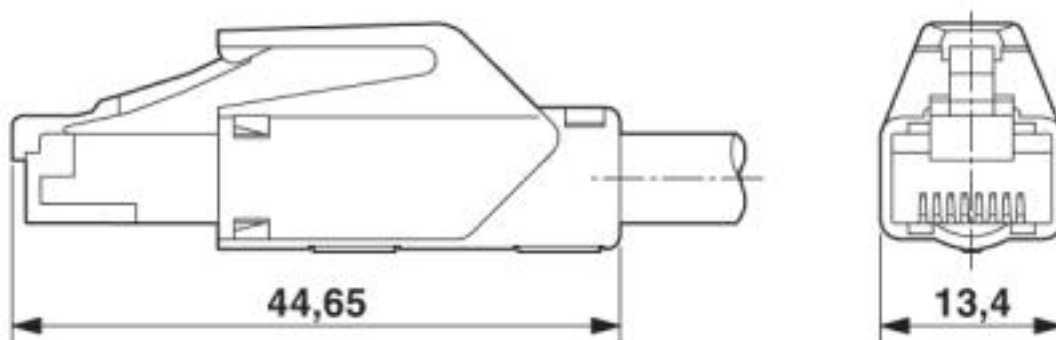

Approvals

Approvals

Approvals

EAC

## Network cable - VS-M12FSBPS-IP20-93E-LI/5,0 - 1404208

### Approvals

Ex Approvals

---

#### Approval details

EAC



B.00767

---

Phoenix Contact 2019 © - all rights reserved  
<http://www.phoenixcontact.com>

PHOENIX CONTACT GmbH & Co. KG  
Flachsmarktstr. 8  
32825 Blomberg  
Germany  
Tel. +49 5235 300  
Fax +49 5235 3 41200  
<http://www.phoenixcontact.com>