

This appliance can be used by children aged from 8 years and above and persons with reduced physical, sensory or mental capabilities or lack of experience and knowledge if they have been given supervision or instruction concerning use of the appliance in a safe way and understand the hazards involved. Children shall not play with the appliance. Cleaning and user maintenance shall not be made by children without supervision.

The specific instructions related to the safe operation of this appliance (as given in 7.12 of this standard) shall be collated together in the front section of the user instructions.

The height of the characters, measured on the capital letters, shall be at least 3 mm.

These instructions shall also available in an alternative format, e.g. on a website.

A fire may result if the appliance is not used with care, therefore:

- be careful when using the appliance in places where there are combustible materials ;
- do not apply to the same place for a long time;
- do not use in presence of an explosive atmosphere;
- be aware that heat may be conducted to combustible materials that are out of sight;
- place the appliance on its stand after use and allow it to cool down before storage;
- do not leave the appliance unattended when it is switched on.

Rohs

Correct Disposal of this product	
	This marking indicates that this product should not be disposed with other household wastes throughout the EU. To prevent possible harm to the environment or human health from uncontrolled waste disposal, recycle it responsibly to promote the sustainable reuse of material resources. To return your used device, please use the return and collection systems or contact the retailer where the product was purchased. They can take this product for environmental safe recycling.

Manufacturer:

AOYUE INTERNATIONAL LIMITED

Jishui Industrial Zone, Nantou, Zhongshan City,

Guangdong Province, P.R.China

<http://www.aoyue.com>

AOYUE[®]

INT 701A++

Advanced Repairing System

INSTRUCTION MANUAL

Thank you for purchasing Aoyue Int701A++ Repairing System.
It is important to read the manual before using the equipment.
Please keep manual in accessible place for future reference.



BASIC TROUBLESHOOTING GUIDE

This manual is designed to familiarize and instruct the operator with the proper usage and maintenance of the equipment. The "Care and Safety Precautions" section explains the hazards of using any type of soldering or reworking device. Please read carefully and observe the guidelines in order to maximize usage and minimize the risk of injury or accidents .

Product Description 3
Specifications 4
Package Inclusion 5
Safety Precautions 6
Assembly and Preparation 7
Control Panel Guide 8
Operating Guidelines 9-11
Auto-Sleep Functions 12
Digital Calibration 13-15
Care and Maintenance 16- 18
Basic Troubleshooting Guide 19

PROBLEM 1: THE UNIT HAS NO POWER

- 1. Check if the unit is switched ON. Power switch located at the back.
2. Check the fuse. Replace with the same type if fuse is blown.
3. Check the power cord and make sure there are no disconnections.
4. Verify that the unit is properly connected to the power source.

PROBLEM 2: TEMPERATURE DISPLAY SHOWS "PEN"

Description: Soldering Iron digital display shows the message "Pen"

SOLUTION:

The soldering iron connecting with the main unit is not detected. Reconnect soldering iron terminal to the main unit. Sensor connection may be damaged, check for cord damage or sensor damage.

PROBLEM 3: TEMPERATURE DISPLAY SHOWS "Gun"

Description: Desoldering gun digital display shows the message "Gun"

SOLUTION:

The desoldering gun connecting with the main unit is not detected. Reconnect desoldering gun terminal to the main unit. Sensor connection may be damaged, check for cord damage or sensor damage.

PROBLEM 4: THE UNIT IS VERY NOISY

SOLUTION:

Make sure the screw at the center of the base of the main unit has been removed. This holds the pump in place during transportation and needs to be removed before using the equipment.

PROBLEM 5: UNIT SHOWS UNCONVENTIONAL BEHAVIOR

Description: Unit operates erratically.

SOLUTION1: Try to switch OFF the device and switch ON again. Unplug the system from the main power source and plug in again when necessary

OTHER PROBLEMS NOT MENTIONED:

Contact the vendor.

SPARE PARTS LIST

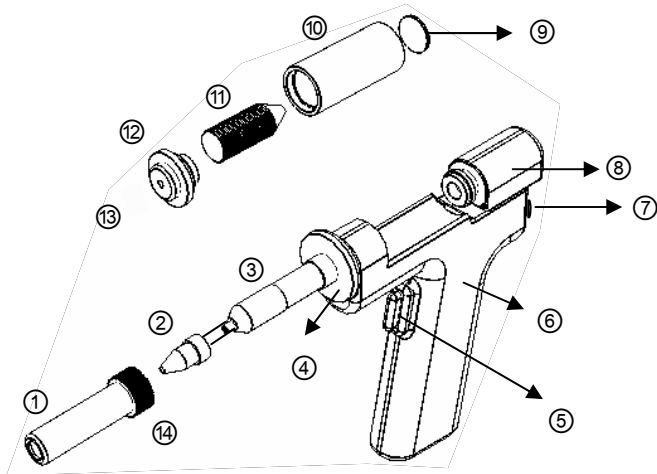

#	Part No.	Part Name
①	30129	Desoldering Gun Tip Cylinder with Tip Lock
②	302082	Desoldering Tip 1.0MM
	302092	Desoldering Tip 1.5MM
	301212	Desoldering Tip 1.8MM
③	C005A	Desoldering Gun Heating Element
④	301282	Heat Guard Assembly
⑤	3021X	Red Release Knob
⑥	3072D	Desoldering Gun Outer Case
	3074D	Desoldering Gun Outer Case
⑦	3021X	Release Knob
⑧	3035X	Back Holder Assembly
⑨	30180X	Filter Pad
	3017J	Pack Of 6 Filter Pad
⑩	3022X	Filter Pipe
⑪	201252	Spring Filter
⑫	3024X	Filter Pipe Cap
⑬	3025X	Silicone Pad
⑭	20133	Tip Lock only

PRODUCT DESCRIPTION

The Aoyue Int701A++ Advanced Repairing System is a reworking equipment that combines the functionality of 70W Soldering Iron, Smoke Absorber, and Desoldering Gun in one package.

The dual port system of the Int701A++ allows simultaneous use of the desoldering gun and soldering iron.

It has several advanced features such as solder iron and desoldering gun digital calibration, configurable auto sleep for the soldering iron and desoldering gun.

Finally, the unique, innovative design with digital control panel and display provides precision, safety, and ease of use to match all reworking requirements.

Features:

- Microprocessor-controlled ESD safe equipment.
- 3-in-1 repairing system combining Soldering Iron, smoke absorber, and Desoldering Gun in one sophisticated package.
- Digital control and display of soldering iron temperature, and desoldering gun temperature with touch type panel controls for precision and ease of use.
- The desoldering gun is equipped with air cylinder type vacuum pump for stronger suction and zero-crossing circuit that prevents electrical surges.
- Integrated smoke absorber functionality with filter pad to efficiently absorb and filter harmful fumes.
- User configurable 1 to 60 minute idle-to-auto-sleep mode for additional device protection and power saving.
- Digital calibration for easy temperature calibration
- Compatibility with different kind of soldering tips.

SPECIFICATION

MAIN STATION	
Power Input :	available in 110V / 220V
Station Dimensions:	188(w) x 126(h) x 250(d) mm
Weight:	5.6Kg
SOLDERING IRON	
Power Consumption:	70W
Temperature Range:	200°C - 480°C
Heating Element:	Ceramic Heater
Output Voltage:	24V
DESOLDERING GUN	
Power Consumption:	50W
Temperature Range:	200°C - 480°C
Heating Element:	Ceramic Heater
Output Voltage:	24V

Specifications are subject to change without prior notice.

CARE and MAINTENANCE

Cleaning the Desoldering Tip

CAUTION:

The desoldering gun will be extremely hot. During maintenance, please wear proper protection and work carefully.

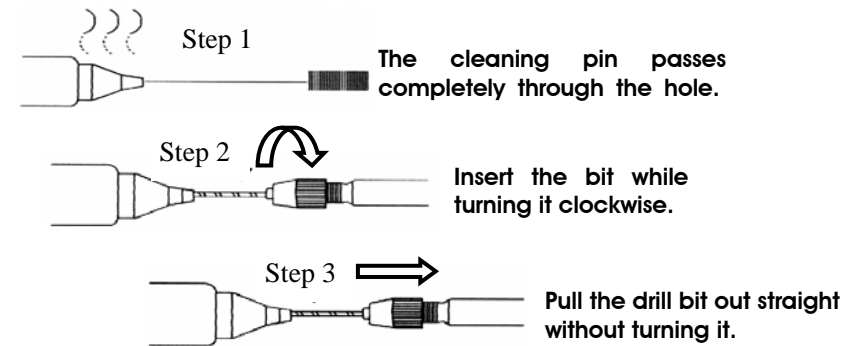

Using Cleaning pin:

Caution: Desoldering gun will be hot during maintenance please use proper materials and equipments to avoid injuries.

When suction efficiency has deteriorated the desoldering gun might be clogged follow these directions to properly clean the desoldering gun.

1. Turn on the desoldering gun and wait for the nozzle to heat up.
2. Slowly insert the cleaning pin while turning the cleaning pin clockwise.
3. Pull out the cleaning pin in a straight motion.

- The cleaning pin will not pass through the nozzle until the solder inside the nozzle is completely melted.
- If the cleaning pin does not pass through the hole in the nozzle, clean with the cleaning drill.

Caution: If the cleaning drill is forced into the nozzle, the drill could break. Please use the proper sized cleaning pin or cleaning drill for the nozzle diameter. If the cleaning pin cannot pass through the hole, replace the Tip.

CARE and MAINTENANCE

WARNING: Unplug the power cord before starting this procedure.

Replacing the Heating Element

1. Unscrew the Tip Lock and pull out Tip Cylinder together with the Tip Lock and remove Desoldering Tip.

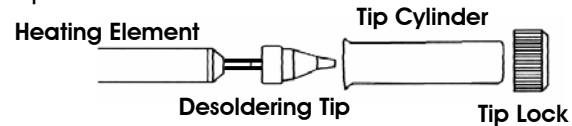

2. Remove the Filter Pipe Assembly.
3. Loosen the 3 fastening screws on the plastic handle and separate the housing.

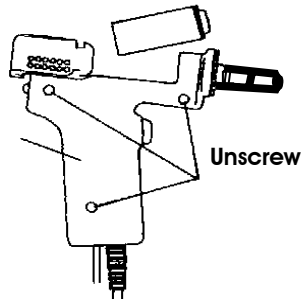

4. De-solder the heating element leads and sensor leads.
5. Detach the terminal and remove the heating element.
6. Insert a new heating element and solder.

Note:

- There is no polarity between leads of the same colors.
- Bend the leads at right angle to prevent short-circuit.

PACKAGE INCLUSIONS

1 unit	701A++Main Station
1 pc.	B003A Soldering Iron with Smoke Absorbing function
1 pc.	B1002A Desoldering Gun with 301212 tip (1.8mm)
1 pc.	2660 Soldering Iron Stand**
1 pc.	201252 Spring Filter
1 pc.	30201X Suction/Vacuum Cover
2 pcs.	30181X Black Filter Pads
1 pc.	201412 Desoldering Gun Holder
1 pc.	302082 Desoldering Tip (1.0mm)
1 pc.	302092 Desoldering Tip (1.5mm)
1 pack	3017J Filter Pads (6pcs.)
1 pc.	3024X Spring Filter Cap
1 pc.	201242 Cleaning Pin
1 pc.	20178 Cleaning Drill
1 pc.	H022 Cleaning Gel
1 pc.	Power Cord
1 pc.	Instruction Manual

* Type of soldering tip included might change depending on availability.
** Kindly refer to soldering iron stand installation on page 7 for parts and instructions.

SAFETY PRECAUTIONS



CAUTION: Improper usage can cause serious injury to personnel and/or damage to equipment. For your own safety, please observe the ff. precautions.

- Check each component after opening the package to make sure everything is in good condition. If there are any suspected damage, do not use the item and report the issue to your vendor.
- Turn OFF the main power switch and unplug the device when moving the device from one location to another.
- Do not strike or subject the main unit to physical shock. Use carefully to avoid injury and damage to any part.
- Handle with care.
 - Never drop or sharply jolt the unit.
 - Contains delicate parts that may break if the unit is dropped.
- Make sure the equipment is always grounded. Always connect power to a grounded receptacle.
- Temperature may reach as high as 480°C when switched ON.
 - Do not use the device near flammable gases, paper and other flammable materials.
 - Do not touch heated parts, which can cause severe burns.
 - Do not touch metallic parts near the tip.
- Disconnect the plug from the power source if the unit will not be used for a long period.
 - Turn off power during breaks, if possible.
- Use only genuine replacement parts.
 - Turn off power and let the unit cool before replacing parts.
- The unit may produce a small amount of smoke and unusual odor during initial usage. This is normal and should not yield any negative result when reworking.
- Soldering process produces smoke — use on well ventilated place.
- Do not alter the unit, specifically the internal circuitry, in any manner.

CARE and MAINTENANCE

Changing Filter Pad and Spring Filter:

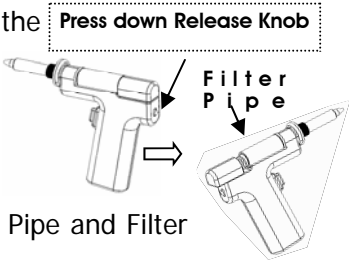
1. Unlock the Filter Pipe by toggling the Release Knob. The Back Holder Assembly would spring back to allow easy extraction of the Filter Pipe Assembly which houses the Filter Pipe Cap, Spring Filter, Filter Pipe and Filter pad.
 
2. After extracting the Filter Barrel Assembly we can now take out the filter spring or the filter pads for cleaning or replacement.
 - If solder is collected in two-thirds of the spring filter replace the spring filter.
 - Replace filter pad if stiff with flux and solder.

3. Re-assemble Filter Pipe Assembly, attach spring filter to the filter barrel cap and place back to the desoldering gun body.

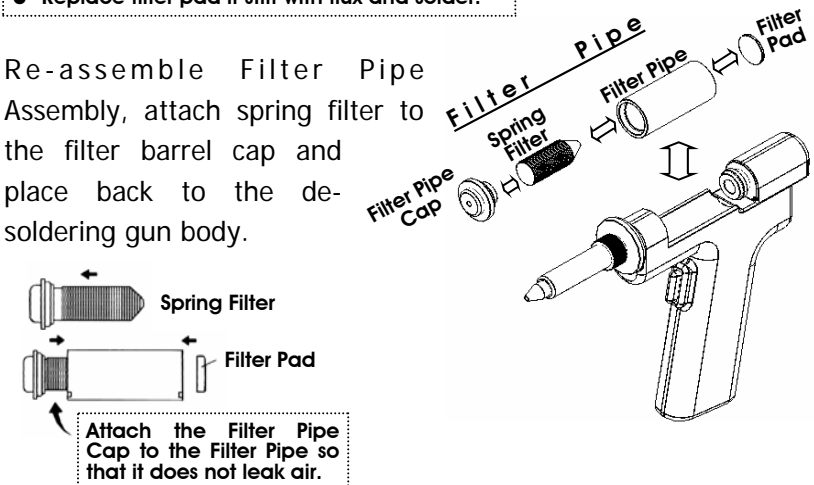

Firmly press the Back Holder Assembly into the Filter Pipe in order to properly seat front cap against the pipe.

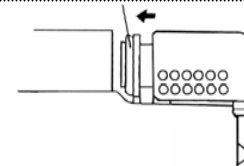

4. Push the Back Holder Assembly back in place, a "click" sound would signify that the it is properly secured.

CARE and MAINTENANCE

De-Soldering Gun Disassembled illustration:

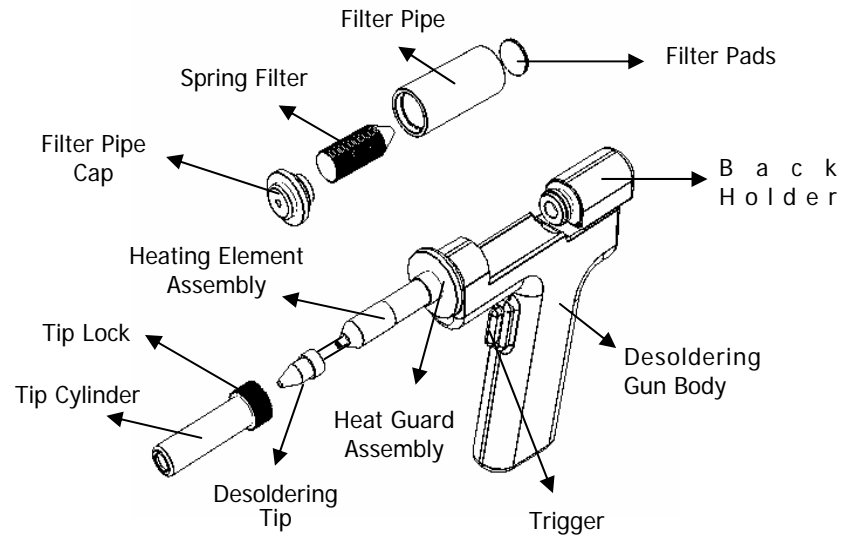

Changing Desoldering Tip:

1. Unscrew the Tip Lock and pull out Tip Cylinder together with the Tip Lock.
2. Pull out Desoldering Tip and replace with new one.
3. Re-secure nozzle by tightening the Tip Lock on its receptacle.

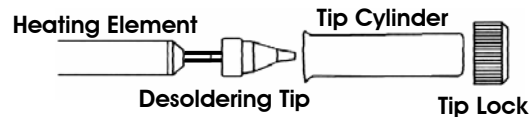
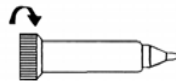

ASSEMBLY and PREPARATIONS

A. Main Station

As soon as the equipment has been removed from the package, **REMOVE THE SCREW** located at the center of the bottom of the main unit. This screw holds the pump in place during transportation.

⚠ WARNING: Failure to remove the screw before using the equipment can cause damage to the system.

B. Soldering Iron Stand

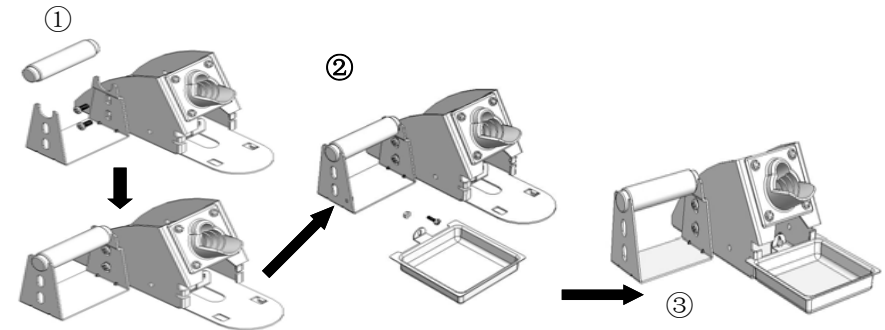

C. Soldering Iron

1. Connect the soldering iron cord assembly to the soldering iron output terminal found at the lower middle portion of the main unit.
2. Place the soldering iron to the soldering iron stand.

D. Smoke Absorber

1. Attach the smoke absorbing tube to the suction vacuum cap. Make sure the cord connections are free from tangles.

E. Desoldering Gun

1. Connect the cord of the desoldering gun to the desoldering gun terminal.
2. Connect the vacuum tube to the suction vacuum cap.
3. Place the desoldering gun onto the holder in preparation for usage.

CONTROL PANEL GUIDE

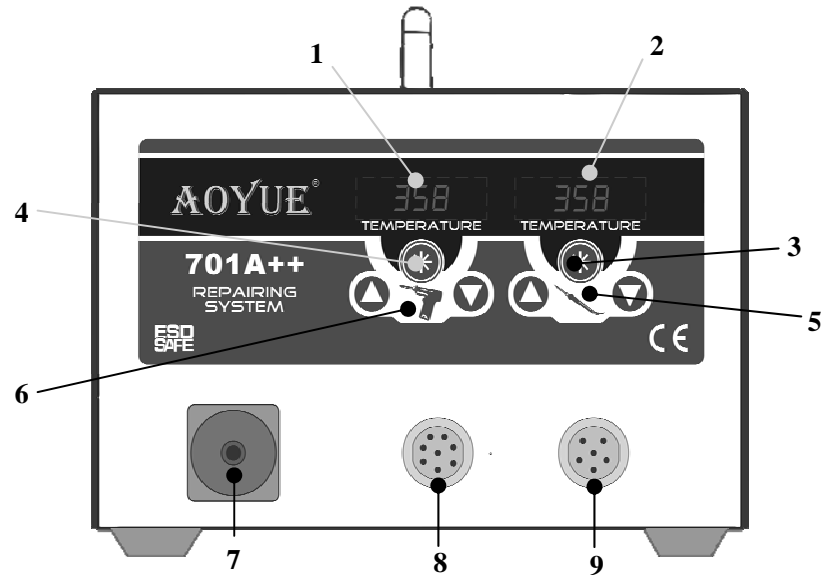

LEGEND:

- 1 — Desoldering Gun Temperature Display
- 2 — Soldering Iron Temperature Display
- 3 — Soldering Iron function button
- 4 — Desoldering Gun function button
- 5 — Soldering Iron Temperature Control Buttons
- 6 — Desoldering Gun Temperature Control Buttons
- 7 — Smoke Absorber Terminal or Vacuum Cap
- 8 — Desoldering Gun Receptacle
- 9 — Soldering Iron Receptacle

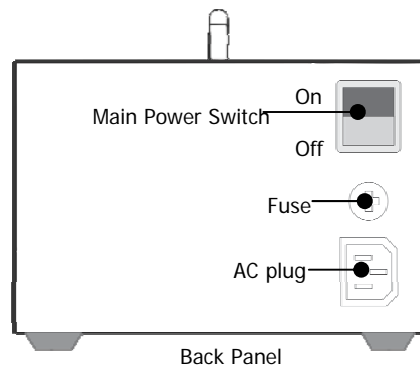

CARE and MAINTENANCE

Vacuum Air Terminal Filters

Filters should be cleaned and replaced regularly to avoid dirt which can clog the air passage. More importantly, this will also effectively clean the toxic fumes produced during soldering process.

De-Soldering Gun

1. Before usage dampen the filter pads with a little bit of water to allow efficient air passage and filter action, re-dampen pads frequently for maximum efficiency.
2. Routinely clean Spring Filter, and replace filter pads when they are dirty or clogged .
3. The solder pathway can be cleaned using the provided Nozzle cleaning pin, use the cleaning pin when pathway seems clogged.
4. Desoldering Gun's sensor connection with the main unit is faulty/ not connected. The device will display "Gun". Indicating a problem with the contacts of the soldering iron or the tip.
5. Desoldering Gun heating element has reached the end of its life, the temperature would consistently display a low value followed by "Err" display. Indicating a problem with the heating element or a reversed sensor polarity.



CARE and MAINTENANCE

Blower/Vacuum Air Terminal Filters

Filters should be cleaned and replaced regularly to avoid dirt which can clog the air passage. More importantly, this will also effectively clean the toxic fumes produced during soldering process.

Soldering Iron Tip

Always keep the solder-plated section of the tip/nozzle coated with a small amount of solder. Oxide coating on the tip of the nozzle reduces its heat conductivity. Coating the tip with a small amount of fresh solder ensures maximum heat conductivity is obtained.

Replacing the Soldering Iron tip

1. Always turn OFF main power switch when removing or inserting a tip.
2. If the tip is hot, use the heat resistant pad to pull it out.
3. Insert the new tip fully into the handle. If the tip is not fully inserted (or if the tip is damaged), the device will display "PLUG". Indicating a problem with the contacts of the soldering iron or the tip.

Soldering Iron Error Messages

1. Soldering Iron connection assembly is not connected or not properly connected to the receptacle on the control panel.
2. Soldering iron sensor, cord or connection is damaged and needs to be replaced. The device will display "PEn". Indicating a problem with the contacts between the soldering iron and the main unit.
3. Soldering iron heating element has reached the end of its life, the temperature would consistently display a low temperature value followed by "Err" display. Indicating a problem with the heating element or a reversed sensor polarity.

OPERATING GUIDELINES

IMPORTANT REMINDERS:

1. Make sure the equipment is placed on a flat stable surface and all the heat-generating components placed on their respective holders or stands.
2. Ensure all terminal connections are properly secured.

IMPORTANT: Please refer to the **CONTROL PANEL GUIDE** page for buttons and display panel directory.

A. INITIAL PROCEDURES

1. Plug the device to the main power source using the power cord provided in the package.
2. Switch ON the device by activating the main power switch.
3. The display panels, will display show "OFF". The system will remain at this state until the user activates a function.

B. SOLDERING IRON

1. Connect the Soldering Iron connection assembly to the 7-pin receptacle located at the front of the control panel ("9" from the CONTROL PANEL GUIDE).
2. Follow the initial procedures ("**A. INITIAL PROCEDURES**").
3. Connect the vacuum tube to the Smoke Absorber Terminal or Vacuum Cap ("7" from the control panel). If smoke absorber function is to be used.
4. To activate the "SOLDER IRON" function, press and hold the soldering iron function button for 3 to 5 seconds ("3" from control panel). The soldering iron temperature display will momentarily show the current set temperature then switch to displaying the actual temperature.
5. Adjust the soldering iron temperature using the SOLDERING IRON TEMPERATURE ADJUSTMENT buttons ("5" from the control panel).
6. To activate the smoke absorber function, simultaneously press both up and down button of the soldering iron temperature adjustment button ("5" from the control panel).

OPERATING GUIDELINES

7. Start using the soldering iron as soon as desired temperature is reached.
8. To deactivate the SMOKE ABSORBER function, simultaneously press both up and down button of the soldering iron temperature adjustment button ("5" from the control panel).
9. To deactivate the soldering iron function press and hold the soldering iron function button for 3 to 5 seconds ("3" from control panel).
10. Allow sufficient time for the soldering iron to cool down before keeping in a safe storage.

C. DESOLDERING GUN

1. Connect the De-soldering gun connection assembly to the 8-pin receptacle located at the front of the control panel ("8" from the CONTROL PANEL GUIDE).
2. Follow the initial procedures ("**A. INITIAL PROCEDURES**").
3. Connect the vacuum tube to the Smoke Absorber Terminal or Vacuum Cap ("7" from the control panel).
3. To activate the "DESOLDER GUN" function, press and hold the de-soldering gun function button for 3 to 5 seconds ("6" from control panel). The de-soldering gun temperature display will momentarily show the current set temperature then switch to displaying the actual temperature.
5. Adjust the desoldering gun temperature using the DESOLDERING GUN TEMPERATURE ADJUSTMENT buttons ("6" from the control panel).
6. Allow the desoldering gun's tip and its barrel to heat up. Tip temperature can be reached within 5-6 minutes and its barrel would obtain optimum temperature 5-9 minutes after the tip temperature has been reached. If upon initial use solder gets stuck at the end of the barrel, clean the barrel and wait a few more minutes for the barrel to heat up.

DIGITAL CALIBRATION

Solder Iron Digital Temperature Calibration Example

- The external temperature sensor displays 250 degrees.
- The set temperature and displayed actual temperature of the soldering iron is 300 degrees.
- $300 - 250 = 50$. An additional adjustment of 50 degrees is required. Upon entering calibration mode, the display shows "010", indicating a calibration number of 10 is already present.
- Therefore $10 + 50 = 60$.
- We adjust from "010" to "060" by pressing the up button of the Soldering Iron Temperature Adjustment button.
- Save and exit calibration mode.
- The external temperature sensor would now display 298 to 302.

Desoldering Gun Digital Temperature Calibration Example

- The external temperature sensor displays 300 degrees.
- The set temperature and displayed actual temperature of the soldering iron is 350 degrees.
- $300 - 350 = -50$. An additional adjustment of -50 degrees is required. Upon entering calibration mode, the display shows "010", indicating a calibration number of 10 is already present.
- Therefore $10 - 50 = -40$.
- We adjust from "010" to "-40" by pressing the down button of the Desoldering Gun Temperature Adjustment .
- Save and exit calibration mode.
- The external temperature sensor would now display 298 to 302.

NOTES:

- Calibration will only make the newly calibrated point the most accurate. Other temperature points may be a little off.

DIGITAL CALIBRATION

B. Utilizing the Desolder Gun Digital Temperature Calibration

By default, the system is properly calibrated but for some cases when a little adjustment of the desoldering gun temperature is required the following procedure can be done.

1. Turn on the desoldering gun function.
2. Set to appropriate temperature you want to calibrate. Place the tip of the desoldering gun on an external temperature meter.
3. The readings on the external temperature sensor should be more or less equal to the displayed temperature.
4. If there are large discrepancy in the temperature reading we can re-calibrate the temperature setting. First write down the set temperature of the soldering iron and the actual temperature reading from the external temperature meter. For example:

set temperature = **300**

external temperature = **350**

Calibration needed = **-50**

5. Turn off the Desoldering Gun Function. Simultaneously press and hold for 5 seconds the Desoldering Gun Function button and the Desoldering Gun Up button .
6. The Desoldering Gun Temperature Display ("1" from the control panel) . Will switch to "000" indicating it is now in the desoldering gun digital calibration adjustment mode. The calibration range is from "-50" to "050" . The leading "-" sign signifies a negative calibration number while the leading "0" signifies a positive calibration number.
7. Use the Desoldering Gun Temperature Adjustment buttons ("6" from the control panel) to increase or decrease the calibration number. In our example the set temperature is 300 but the actual temperature is 350, There is need to decrease the temperature by 50 degrees. Press the down button until we reach "-50" .
8. Save the value by pressing and holding the Soldering Iron Function button ("4" from the control panel).

OPERATING GUIDELINES

7. Check the tip temperature with an external temperature sensor, adjust temperature settings higher or lower for the right temperature. Or recalibrate at the desired temperature level
8. Ensure that all the solder is melted before triggering the pump. (Partially melted solder will still be sucked up however it would clog the barrel).
9. Upon pressing the pump trigger, hold the trigger for 1 to 2 seconds longer, as larger lumps of solder may need a longer suction time to clear the barrel and go into the filter.
10. Clean the filter and dampen the sponge frequently during and after usage to allow better suction power.
11. To deactivate the desoldering gun function press and hold the desoldering gun function button for 3 to 5 seconds ("4" from control panel).

Notes:

- Industry recommended tip temperature for soldering is 600 to 610F (315 to 320C) for standard solders and 650 to 700F (340 to 370) for unleaded solders
- Because of the difference in the heating element and size of the soldering iron tip and desoldering gun, the soldering iron will heat up faster than the desoldering gun. This is normal and does not have any impact on the system's performance.
- There will be a slight drop in temperature display once the trigger of the desoldering gun is used. This is due to rapid intake of air in which temperature is significantly cooler than the desoldering gun tip. When the system detects this, it will automatically adjust the temperature to compensate for the temperature difference.



NOTICE: When using the desoldering gun and soldering iron simultaneously, the smoke absorbing function of the soldering iron will be deactivated. This is to give priority to the desoldering gun.

AUTO SLEEP FUNCTIONS

Auto-Sleep Mode (Soldering Iron and Desoldering Gun)

The sleep timer can be configured to power down the soldering iron or desoldering gun after a defined time. When in sleep mode three dashes " - - - " will be shown indicating that it is now in sleep mode. To reactivate the simply push its corresponding function or adjustment button.\

By default the system's sleep duration is 0 indicating the sleep timer is disabled. To activate the sleep function follow the procedures below.

Changing SLEEP Timer (Soldering Iron)

1. With the soldering iron function turned off. Simultaneously press and hold for 5 seconds the Soldering Iron Function button and the Soldering Iron Down button .
2. The Soldering Iron Temperature Display ("2" from the control panel) . Will switch to "t00" indicating it is now in the soldering iron sleep timer adjustment mode.
3. Use the Soldering Iron Temperature Adjustment buttons ("5" from the control panel) to increase or decrease the sleep duration. Timer is adjustable from 1 to 60 minutes, a value of 0 indicates that the sleep timer function is turned off.
4. Confirm the change by pressing and holding the Soldering Iron Function button ("3" from the control panel).

Changing SLEEP Timer (Desoldering Gun)

1. With the desoldering gun function turned off. Simultaneously press and hold for 5 seconds the Desoldering Gun Function button and the Desoldering Gun Down button .
2. The Desoldering Gun Temperature Display ("1" from the control panel) . Will switch to "t00" indicating it is now in the gun sleep timer adjustment mode.
3. Use the Desoldering Gun Temperature Adjustment buttons ("5" from the control panel) to increase or decrease the sleep duration. Timer is adjustable from 1 to 60 minutes, a value of 0 indicates that the sleep timer function is turned off.
4. Confirm the change by pressing and holding the Desoldering Gun Function button ("4" from the control panel).

DIGITAL CALIBRATION

A. Utilizing the Solder Iron Digital Temperature Calibration

By default, the system is properly calibrated but for some cases when a little adjustment of the soldering iron temperature is required the following procedure can be done.

1. Turn on the soldering iron function.
2. Set to appropriate temperature you want to calibrate. Place the tip of the soldering iron on an external temperature meter.
3. The readings on the external temperature sensor should be more or less equal to the displayed temperature.
4. If there are large discrepancy in the temperature reading we can re-calibrate the temperature setting. First write down the set temperature of the soldering iron and the actual temperature reading from the external temperature meter. For example:

set temperature = **350**

external temperature = **300**

Calibration needed = **+50**

5. Turn off the Soldering Iron Function. Simultaneously press and hold for 5 seconds the Soldering Iron Function button and the Soldering Iron Up button .
6. The Soldering Iron Temperature Display ("2" from the control panel) . Will switch to "000" indicating it is now in the soldering iron digital calibration adjustment mode. The calibration range is from "-50" to "050" . The leading "-" sign signifies a negative calibration number while the leading "0" signifies a positive calibration number.
7. Use the Soldering Iron Temperature Adjustment buttons ("5" from the control panel) to increase or decrease the calibration number. In our example the set temperature is 350 but the actual temperature is 300, There is need to increase the temperature by 50 degrees. Press the up button until we reach "050" .
8. Save the value by pressing and holding the Soldering Iron Function button ("3" from the control panel).