

**STRAIGHT SQUARE FLANGE JACK SOLDER TYPE
CABLE .141**

R185.252.000
SERIES 7-16

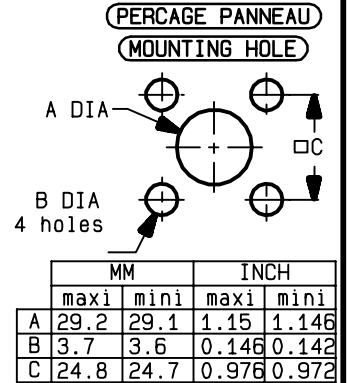
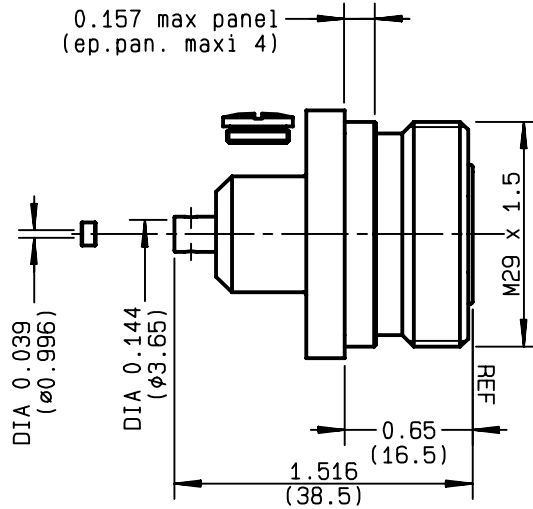
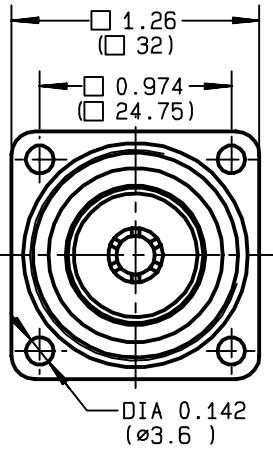

NOMINAL IMPEDANCE	50 Ω
FREQUENCY RANGE	0-7.5 GHz
TEMPERATURE RATING	-55/+105 °C
V.S.W.R	1.25 + x F(GHz)Maxi
RF INSERTION LOSS	0.05 √F(GHz) dB Maxi
VOLTAGE RATING	1000 Veff Maxi
DIELECTRIC WITHSTANDING VOLTAGE	1500 Veff Mini
INSULATION RESISTANCE	10000 MΩMini
HERMETIC SEAL	NA Atm.cm ³ /s
LEAKAGE (pressurized only)	NA
MECHANICAL DURABILITY	500 Cycles
WEIGHT	95 gr
SPECIFICATION	

CABLES : **KS 2**
RG 402

OTHERS CHARACTERISTICS

ROS	1.10	a 3 GHz
CABLE RETENTION	500	N Mini
CENTER CONTACT RETENTION		
Axial force - mating end	200	N Mini
Axial force - opposite end	100	N Mini
Torque	25	cm.N Mini
RECOMMENDED TORQUES		
Mating	NA	cm.N
Panel nut	NA	cm.N
Clamp nut	NA	cm.N

CONNECTOR PARTS	MATERIALS	FINISH	(all values are given in micrometers)
BODY	BRASS	BBR 0.5 OVER SILVER	3
OUTER CONTACT	BRASS	SILVER 5 OVER COPPER	0.5
CENTER CONTACT	BERYLLIUM COPPER	SILVER 5 OVER COPPER	0.5
INSULATOR	PTFE	-	
GASKET	-	-	
OTHERS PIECES	BRASS	BBR 2	

GAUTIER

ISSUE	CREATION DATE	FILE PART-NUMBER
9944C00	13/10/1994	EPC96-02



RADIALL®

The information given here is subject to change without notice.
Design changes may be in order to improve the product.

Connect to the future



R185.252.000

ISSUE **9944C00** SERIES **7-16**

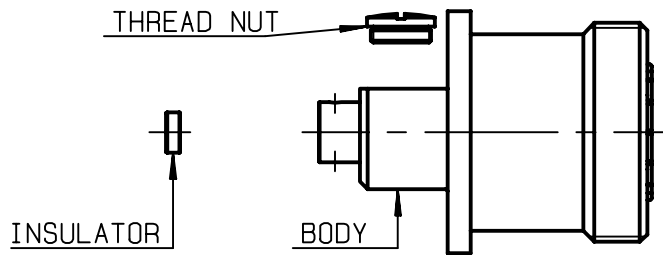

We recommend a thermal preconditioning cable .

①

Strip the cable .
 Stripping tool R282 053 000
 Positioner R282 066 010
 -

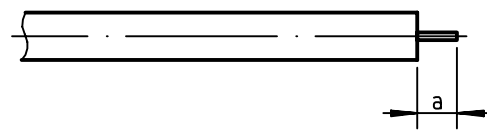

Stripping	a	b	c	d	e
inch	0.177	0	0	0	0
mm	4.5				

②

Slide the insulator onto the cable inner conductor .

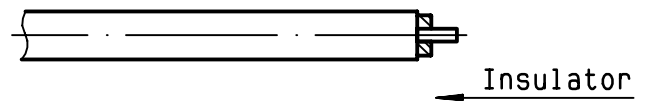

③

Introduce the cable into the connector body until it stops .
 Place the sub assembly into the assembly jig R282 740 030 (or equivalent) and tighten it .
 Solder the body onto the cable .
 Solder the body onto the cable .
 Let the assembly cool down before removing it from the jig .

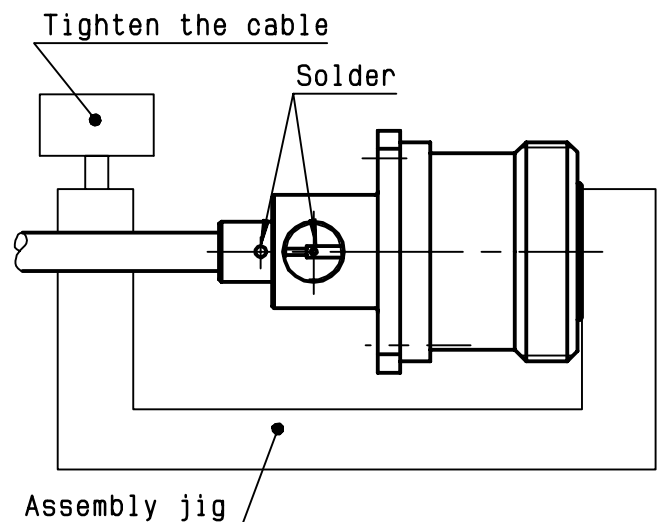

④

Screw the cap .

