

ODU AMC[®] SERIES T

Flexible MIL 38999 qualified connectors and optional cable assemblies for harsh environments

PUSH-PULL
BREAK-AWAY
THREAD-LOCK



A HIGHER
LEVEL OF
FLEXIBILITY

ODU AMC[®] SERIES T

ODU AMC[®]

ODU AMC[®] EASY-CLEAN

ODU AMC[®] HIGH-DENSITY

ODU AMC[®] THREADED CONNECTOR

ODU AMC[®] SERIES T

FEATURES

- Watertight up to 20 m
- 3 locking mechanisms
- Optimized field assembly capability
- Compact design
- Reversed gender option
- Mechanical / color coding
- Crimp termination technology
- EMI shielding
- Tested according MIL standards
- High vibration resistance
- Rugged design
- International protection class IP6K9K
- Standard cable assemblies

MILITARY APPLICATIONS

- Active protection systems (APS)
- Counter drone systems (CUAV)
- Electronic warfare
- Jammer and counter IED systems
- Power distribution devices
- Radar systems
- Remote controlled weapon stations
- Tactical radios
- Training and simulation systems
- Robotics and autonomous systems (RAS)

CIVIL APPLICATIONS

- Deep foundation machinery and equipment
- Forestry
- Heavy construction
- Mining
- Waste industry



All shown connectors are according to IEC 61984:2008 (VDE 0627:2009-11) connectors without breaking capacity (COC). All shown connectors and cable assemblies are rated to a safety extra low voltage (SELV) of less than 50 V AC / 75 V DC, according to IEC 61140:2016 (VDE 0140-1:2016). For more details, please refer to page [80](#).

All dimensions are in mm.

Some figures are for illustrative purposes only. Subject to change without notice. Errors and omissions excepted. We reserve the right to change our products and their technical specifications at any time in the interest of technical improvement. This publication supersedes all prior publications.

This publication is also available as a PDF file that can be downloaded from www.odu-connectors.com

Issue: 2023-02

Data transmission protocols

The contact arrangement of an ODU data transmission connector differs from a standard data transmission connector due to the robust ODU specific design. However, the ODU design meets the electrical specifications of the respective standard data transmission protocol.

TABLE OF CONTENTS

PRODUCT INFORMATION	5
ODU AMC® Connectors at a glance	6
ODU AMC® Series T features	7
Circular connectors complete with cable assembly	9
Locking mechanisms (Push-pull / Break-away / Thread-lock)	13
ODU Fiber Optic Expanded Beam Performance	15
CONFIGURATION	17
ODU AMC® Series T field assembly capability	18
Sample configuration step by step	20
Cable specifications	23
ODU AMC® SERIES T	29
Summary ODU AMC® Series T	30
Plugs and cable assemblies	32
Receptacles and cable assemblies	38
Plugs with backshell termination and cable assemblies	44
Receptacles with backshell termination and cable assemblies	47
Contact inserts and PCB layouts	50
ACCESSORIES	55
MIL STD-contacts	56
Crimp sleeves	57
Backshells	58
Band-it	60
Heat-shrink tubes	60
Protection caps	61
Sealing plugs	63
TOOLS	65
Tools for shielded termination	66
Contact crimp tools	66
Insertion and removal tools	67
Contact retention tools	67
Insert retention tools	68
Nutdriver for slotted nut	68
Complete your connector system	69
Order information for possible cable termination types	71
TECHNICAL INFORMATION	73
Technical data – ODU AMC® Series T	74
International protection classes	78
Protections of ODU AMC® Series T	79
Explanations and details of safety requirements	80
Conversions / AWG	81
International color code / IC-code	82
Current load of contacts	83
Technical terms	85

Printed on certified recycled paper.



For assembly instructions please refer to our website: odu-connectors.com/downloads



ODU AMC® SERIES T



PRODUCT INFORMATION

ODU AMC® Connectors at a glance	6
ODU AMC® Series T features	7
Circular connectors complete with cable assembly	9
Locking mechanisms (Push-pull / Break-away / Thread-lock).....	13
ODU Fiber Optic Expanded Beam Performance.....	15

ODU AMC® CONNECTORS AT A GLANCE

The ODU AMC® series has been designed especially for use under extreme conditions. These incredibly robust series of metal circular connectors leave absolutely nothing to be desired in terms of toughness and transmission reliability.

They are in their element under extreme field conditions: rugged, watertight and easy to clean. Low weight, low light reflection surfaces, excellent EMC properties and a compact construction make these connectors the ideal choice for military and security technology applications.

These connectors are available as system solutions with cable assemblies for harsh environments and with straight or right-angled overmolding.



RELATED PRODUCTS IN THE ODU CIRCULAR CONNECTOR SERIES



- High speed data transmission versions
- Secure push-pull locking and break-away function
- Contacts for solder and PCB termination
- International protection class IP6K8 and IP6K9K
- Standard cable assemblies with UL rated cables and single wires

- Pogo pin contacts can be easily cleaned and are resilient against damage caused by dirt and debris ingress
- Break-away function
- International protection class IP6K8 and IP6K9K
- Standard cable assemblies with UL rated cables and single wires

- Small and compact design
- High contact density
- High speed data transmission versions
- Break-away function
- International protection class IP6K8 and IP6K9K
- With dual-locking option
- Standard cable assemblies with UL rated cables and single wires

- High reliability for harsh environments
- Thread-lock with ratchet mechanism (180°)
- High vibration resistance
- Contacts for solder and PCB termination
- Up to 2,000 mating cycles
- International protection class IP6K8 and IP6K9K
- Standard cable assemblies with UL rated cables and single wires

ODU AMC® SERIES T – A HIGHER LEVEL OF FLEXIBILITY



ODU AMC® SERIES T – FEATURES

- 2 shell sizes (09 / 12)
- From 5 to 18 contacts
- Qualification based on MIL-STD 38999
- Multiple sealed mechanical components
- Waterproof in accordance with MIL-Standard 810 (up to 20 m)
- International protection class IP6K8 and IP6K9K
- Standard cable assemblies with UL rated cables and single wires
- High speed data transmission versions
- Operating temperature range from -65 °C to +175 °C
- Compatible with MIL-STD crimp contacts
- Compatible with MIL-DTL-85049 backshells
- Customizable with MIL-STD sealing plugs
- Highly flexible & field repairable solution



JTAC

CIRCULAR CONNECTORS COMPLETE WITH CABLE ASSEMBLY

CONNECTOR
MEETS
CABLE

ODU AMC SERIES T® is the ideal circular connector for a wide range of applications. Whether used for transmitting power, signals or data with special data transmission protocols, this circular connector in its robust metal connector plug housing impresses customers – with its exceptional quality, high reliability and ideal handling characteristics, all in accordance to the 38999 Qualification.

The push-pull principle reliably ensures that the connector will not come loose during use: Once plugged in, the ODU AMC® Series T locks itself into the receptacle automatically. It cannot be separated by pulling on the cable. Instead, the connector can easily be demated from the receptacle by pulling on the outer housing.

Protection against water, dirt and dust: ODU AMC® Series T can be configured entirely in accordance with your application and requirements. You can choose from connectors in two sizes – the cable connection is available both as a molded variant and with standard MIL backshells (MIL standard 38999). The plugs can be easily assembled in the field, even under difficult conditions – the individual connector can be easily replaced or repaired on site by military personnel.

COMPLETE SYSTEM SOLUTIONS

Every connection has a unique cable requirement. Make no compromise when it comes to the quality of the complete interconnect system. ODU gives you the complete system solution from one source, without the need for an intermediary supplier.

Services include:

- + One point of contact for a complete system
- + High technical expertise in the processing of third-party products
- + 100 % final inspection
- + Custom labeling and cable printing
- + Close collaboration with leading cable manufacturers
- + Process-controlled solder and crimp monitoring from initial samples to full production
- + Production in accordance with UL possible (File: E333666)
- + Inhouse Technology Test Center for the development of technologies for customer-specific requirements
- + Production according to IPC standards



ODU AMC[®] SERIES T – SIZES

2 SHELL SIZES

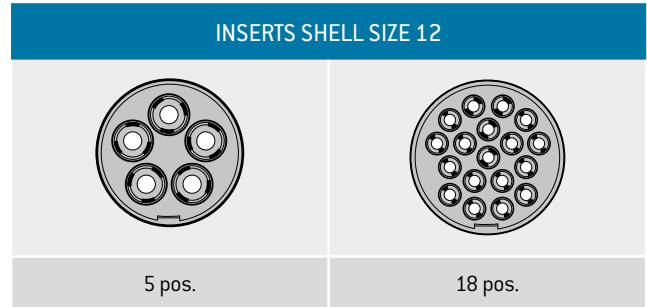
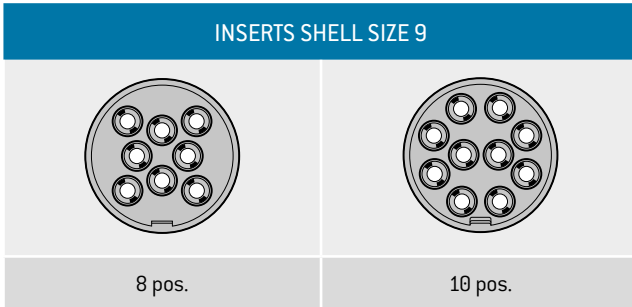



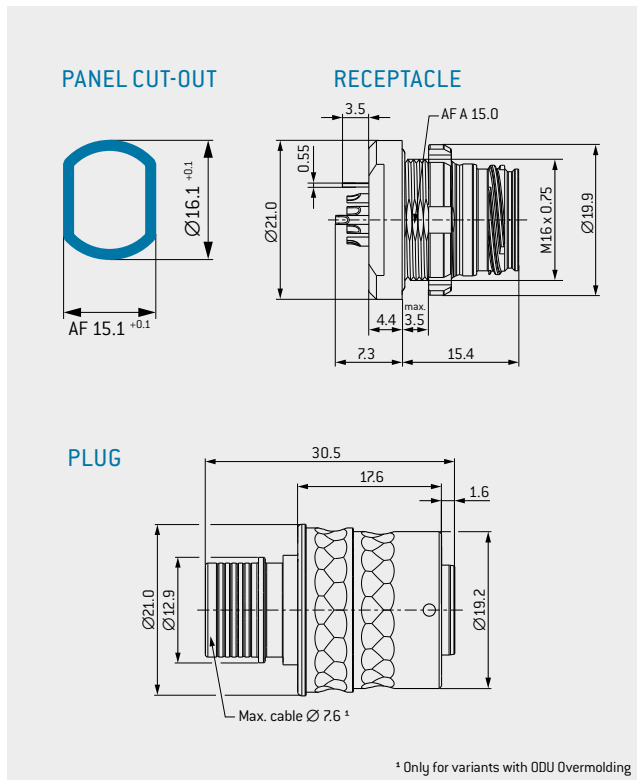



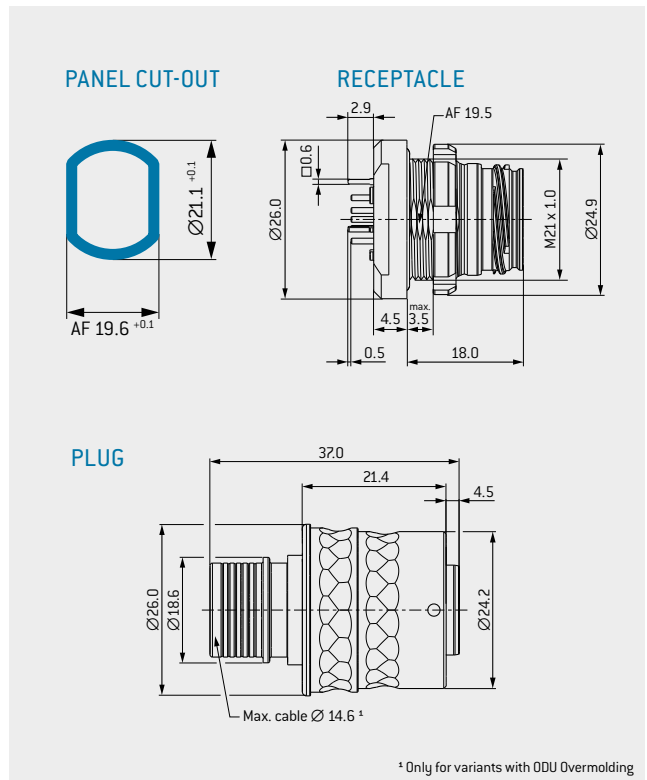

EXAMPLE PUSH-PULL SIZE 9



EXAMPLE PUSH-PULL SIZE 12



ODU AMC[®] SERIES T – CODING OPTIONS

	A	B	C	D
Mechanical coding: receptacle front view				
Color coding				
	LIGHT BROWN	RED	BLUE	GREEN

FULL-MATING INDICATOR

The full-mating indicator shows if the plug is completely and correctly connected. Once connected, the fullmate indicator should no longer be visible.

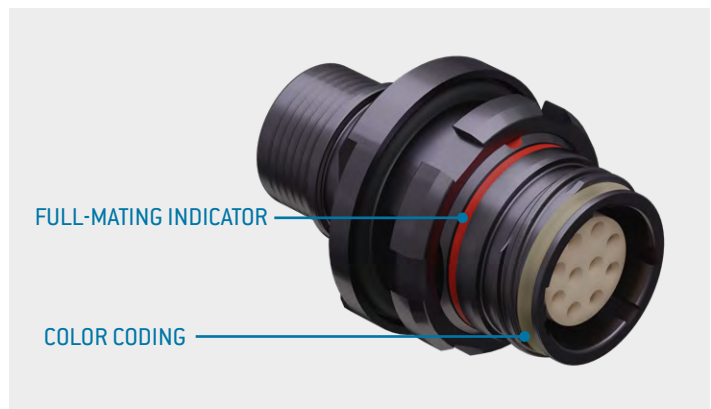

LOCKING STYLE OPTIONS

	Coding	No. of possible mechanical codings	Shell size	Plug diameter in mm	Max. cable diameter in mm ¹	Max. number of contacts	Solder ²	Crimp	PCB ²
 Push-pull	Pin and groove	4	09	21	7.6	10	●	●	●
			12	26	14.6	18			
 Break-away	Pin and groove	4	09	18.5	7.6	10	●	●	●
			12	24.2	14.6	18			
 Thread-lock	Pin and groove	4	09	18.4	7.6	10	●	●	●
			12	24.9	14.6	18			

¹ Cable diameter for ODU overmolded version. For backshell termination see from page [44](#).

² Only for panel mounted receptacles (GK)

ODU AMC[®] SERIES T LOCKING MECHANISMS

PUSH-PULL LOCKING

The innovative push-pull ball-locking principle ensures reliable and precise mechanical mating and demating within a compact, radial design with small external dimensions.

During the mating process, the balls are pressed into the locking groove on the receptacle by the wave spring. The connection can only be released by manually actuating (pulling back) the outer sleeve of the connector.

Pulling on the cable has no affect on the locking mechanism. For demating in an emergency, the connector can be cleanly unplugged by simply pulling back the outer sleeve, even if the cable is under tension, thus preventing personal injury and damage to equipment.

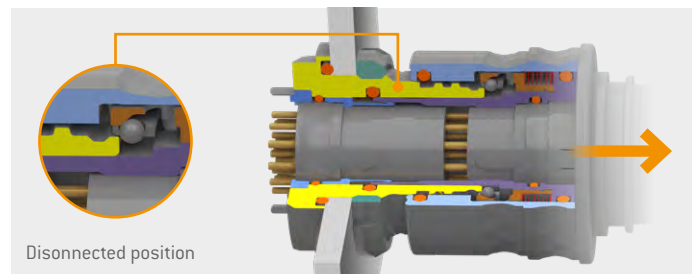
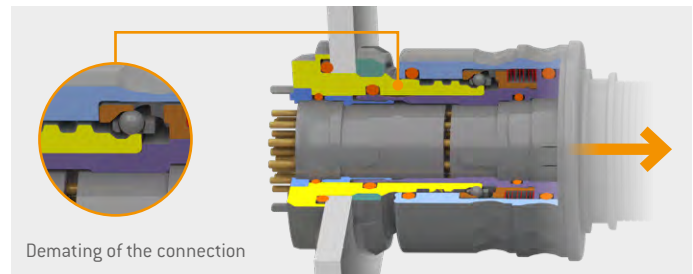
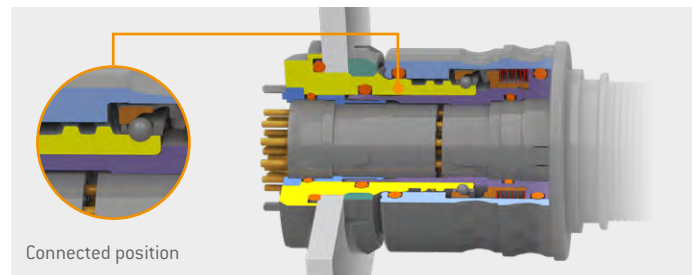

ODU AMC® SERIES T LOCKING MECHANISMS

BREAK-AWAY LOCKING

The break-away function allows connectors to be mated and unmated quickly and reliably. During the mating process, a locking ring inside the receptacle engages corresponding grooves on the plug. Once established, the connection will be maintained as long as axial tension on the plug is less than the release limit of the connector system.

The retention mechanism is strong enough to resist minor tension. Pulling lightly on the plug or cable assembly will have no impact on the connection.

If the plug or cable assembly is pulled forcefully, and the release limit of the connector is exceeded then the connectors will separate.

Design features within the connector allow a damage-free demating if either the plug or the cable assembly is pulled away from the receptacle with enough force to overcome the retention mechanism.

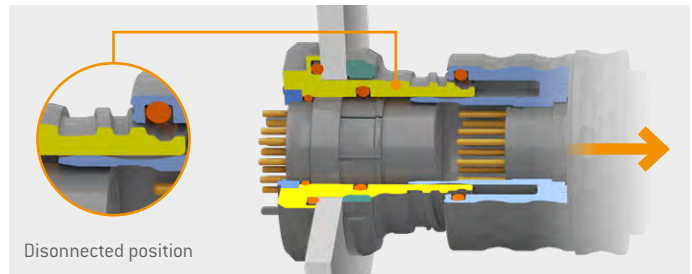
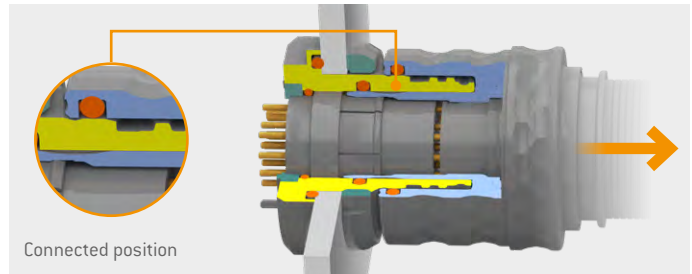

THREAD-LOCK FUNCTION

The thread-lock connector features a triple-start thread that allows it to be securely connected to the receptacle via a 180° turn.

Positive engagement and force closure within the locking mechanism are ensured by means of an integrated stainless steel wave spring and a ratchet mechanism made of high-performance polymers.

The interaction of locking ring, connector housing, and thread thus ensures an extremely secure and vibration resistant connection.

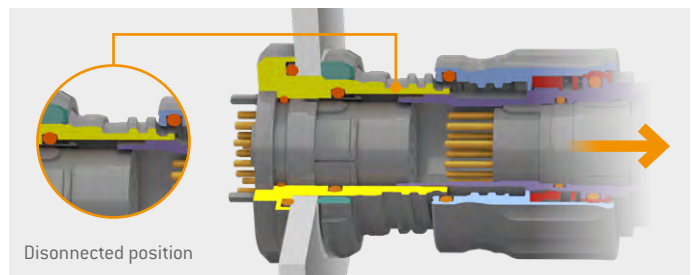
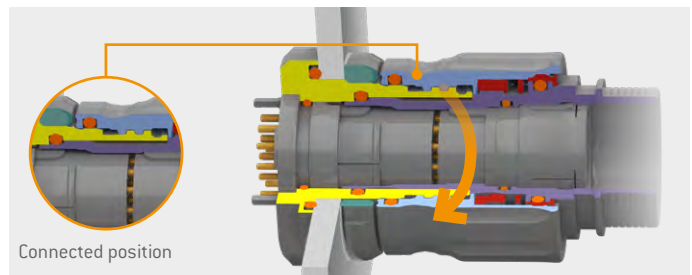

ODU FIBER OPTIC EXPANDED BEAM PERFORMANCE

OPTICAL CHARACTERISTICS

		TYPICAL	MAX.
INSERTION LOSS	SM	< 0.35 dB	< 0.7 dB
	MM	< 0.15 dB	< 0.3 dB
		TYPICAL	MIN.
RETURN LOSS	SM	> 60 dB	≥ 55 dB
	MM	> 45 dB	≥ 35 dB

MECHANICAL CHARACTERISTICS / ENVIRONMENTAL DATA

MATING CYCLES	5,000*
IP CLASS IN MATED CONDITION	IP6K8
OPERATING TEMPERATURE	-40 °C TO +80 °C
VIBRATION	MIL 810G 7.7 G

* Contact transition allows up to 25,000 mating cycles with cleaning every 5,000 mating cycles under controlled conditions. Specifics of the connector series may deviate.

CABLE SPECIFICATION

	SINGLEMODE	MULTIMODE
FIBER	G.657A2	OM4
JACKET	LSZH BLACK	LSZH BLACK
CABLE Ø	6.0 ± 0.2 (MM)	6.0 ± 0.2 (MM)
MIN. BENDING RADIUS (STATIC)	60 MM	60 MM
MIN. BENDING RADIUS (DYNAMIC)	120 MM	120 MM

The ODU AMC® Series T Expanded Beam Performance is an advanced fiber optic solution. It offers high-end transmission characteristics over many mating cycles.

The excellent optical performance remains unchanged even under mechanical stress, environmental influences and harsh ambient conditions.

- + Fiber types: Singlemode and Multimode
- + Configurations: 2 to 12 fibers
- + Outstanding optical performance



ODU AMC® SERIES T



DON'T
FORGET
THE CABLE!

CONFIGURATION

- ODU AMC® Series T field assembly capability [18](#)
- Sample configuration step by step [20](#)
- Cable specifications [23](#)

ODU AMC[®] SERIES T FIELD ASSEMBLY CAPABILITY

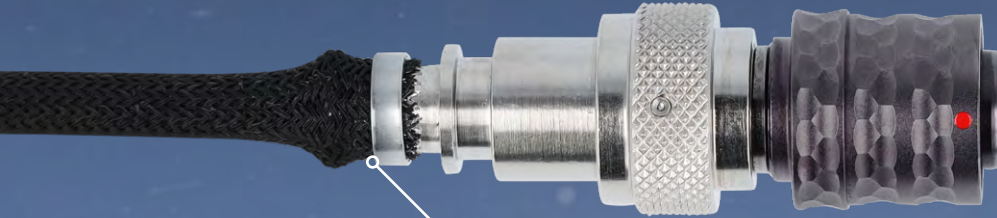

**ODU
PRO ADVICE**

SERVICE LOOP

For better field assembly, include a service loop in the cable design. The additional length of cable or wire simplifies field assembly or damage repair. For example, damaged components can be replaced without replacing the entire cable installation.



YOUR WAY TO AN INDIVIDUAL CONNECTION:

HOW TO CONFIGURE WITH THE CONNECTOR PART NUMBER KEY

This shows you how ODU's part number key is composed. In the first part of the configuration, select the connector plug housing (such as style and size) of the connector. In the middle part of the part number key, you configure the contact insert and in the last part the cable entry.

Type

- A = Break-away plug
- C = Threaded plug
- G = Receptacle
- K = In-line receptacle
- S = Push-pull plug

Style

- 1,6 & K = Standard cable termination
- B = Backshell version

Possible combinations of type / style

- A1 / S1 / C1 / K1 / G6 / GK
- AB / SB / CB / KB / GB

Shell Size

- E = 09, H = 12

Contact configuration

- D = High-speed
- M = Mixed insert
(different contact Ø)
- Ø = standard

Shield connection¹

- Ø = Type A, C, S, K, G6, GB
- P = Print style GK
- L = Solder style GK

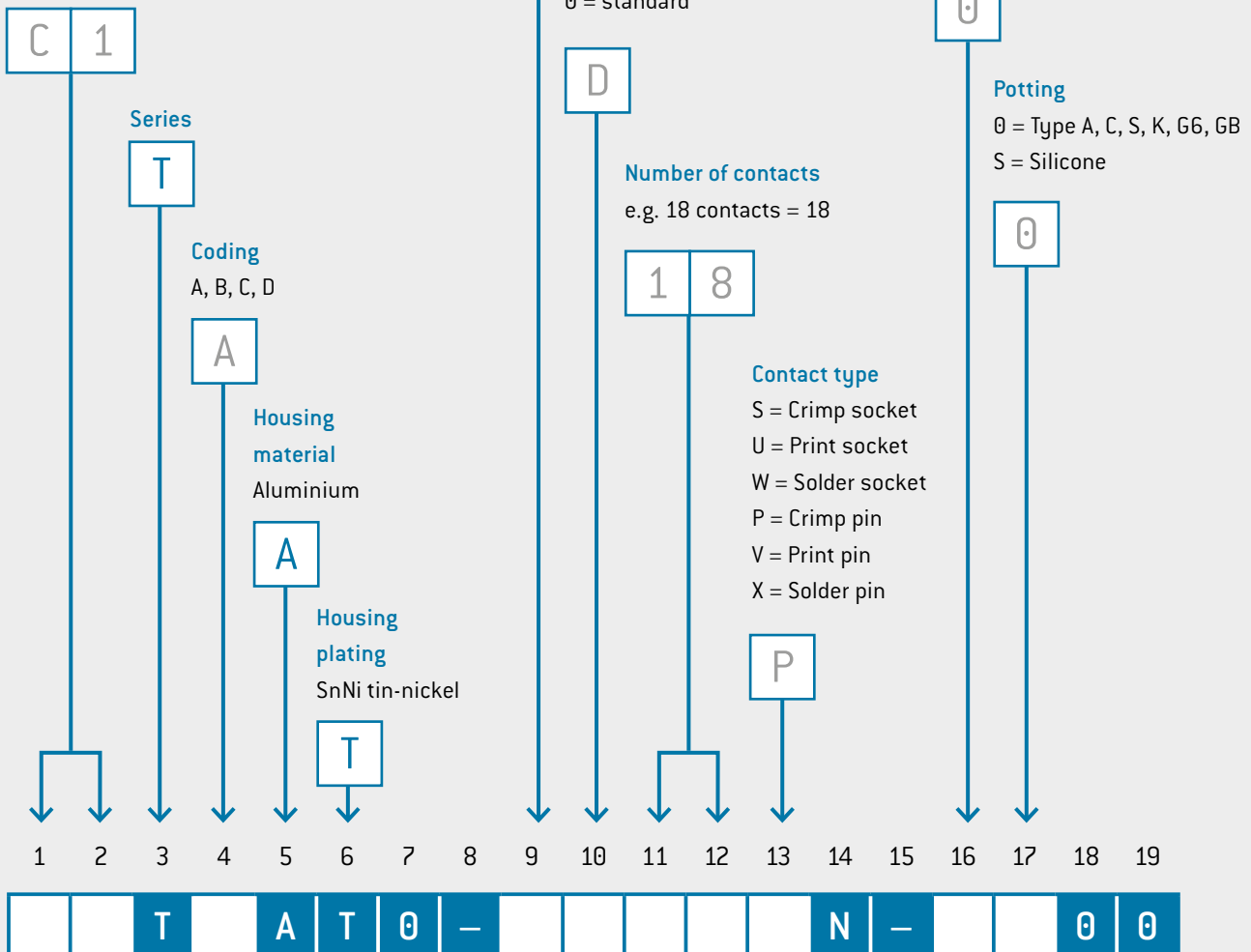

¹ only for GK receptacle

SAMPLE CONFIGURATION STEP BY STEP

The perfect product in just a few steps. These step-by-step instructions show you how to configure your own individual product with the ODU part number key based on a sample configuration.



Plug with thread-lock function, ODU AMC® Series T, coding A, aluminium housing with SnNi tin-nickel plating, shell size 12, mixed insert, 18-position, pin (crimp contacts)

STEP 1: SERIES (SEE POSITION 3)

1	2	3	4	5	6	7	8	9	10	11	12	13	14	15	16	17	18	19
		T				0	-						N	-			0	0



STEP 2: TYPE/STYLE (SEE POSITIONS 1, 2)

PAGE 30

1	2	3	4	5	6	7	8	9	10	11	12	13	14	15	16	17	18	19
C	1	T				0	-						N	-	0	0	0	0

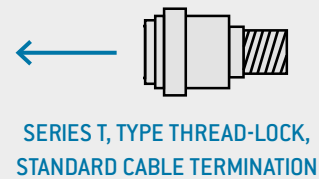

STEP 3: CODING (SEE POSITION 4)

PAGE 33

1	2	3	4	5	6	7	8	9	10	11	12	13	14	15	16	17	18	19
C	1	T	A			0	-						N	-	0	0	0	0

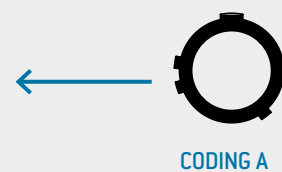

STEP 4: HOUSING MATERIAL (SEE POSITION 5)

PAGE 19

1	2	3	4	5	6	7	8	9	10	11	12	13	14	15	16	17	18	19
C	1	T	A	A		0	-						N	-	0	0	0	0



STEP 5: HOUSING PLATING (SEE POSITION 6)

PAGE 19

1	2	3	4	5	6	7	8	9	10	11	12	13	14	15	16	17	18	19
C	1	T	A	A	T	0	-						N	-	0	0	0	0



STEP 6: SHELL SIZE (SEE POSITION 9)

1	2	3	4	5	6	7	8	9	10	11	12	13	14	15	16	17	18	19
C	1	T	A	A	T	0	-	H					N	-	0	0	0	0

←  SHELL SIZE 12

STEP 7: CONTACT CONFIGURATION (SEE POSITION 10) PAGE 50

1	2	3	4	5	6	7	8	9	10	11	12	13	14	15	16	17	18	19
C	1	T	A	A	T	0	-	H	M				N	-	0	0	0	0

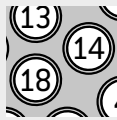
←  MIXED INSERT

STEP 8: NUMBER OF CONTACTS (SEE POSITION 11/12)

1	2	3	4	5	6	7	8	9	10	11	12	13	14	15	16	17	18	19
C	1	T	A	A	T	0	-	H	M	1	8		N	-	0	0	0	0

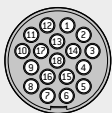
←  18 CONTACTS

STEP 9: CONTACT TYPE (SEE POSITION 13)

1	2	3	4	5	6	7	8	9	10	11	12	13	14	15	16	17	18	19
C	1	T	A	A	T	0	-	H	M	1	8	P	N	-	0	0	0	0

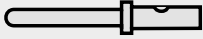
←  CRIMP PIN

YOUR WAY TO AN INDIVIDUAL CABLE ASSEMBLY SOLUTION

HOW TO CONFIGURE WITH THE CABLE NUMBER KEY

This shows to you how ODU's Cable number key is composed. First part of the configuration is "C" for cable.

The digits 2-7 must be transferred from the connector part number.

In the middle part of the cable number key, you configure bend relief, color and count number.

The last 6 positions determine the length of the cable in mm.

Cable assembly

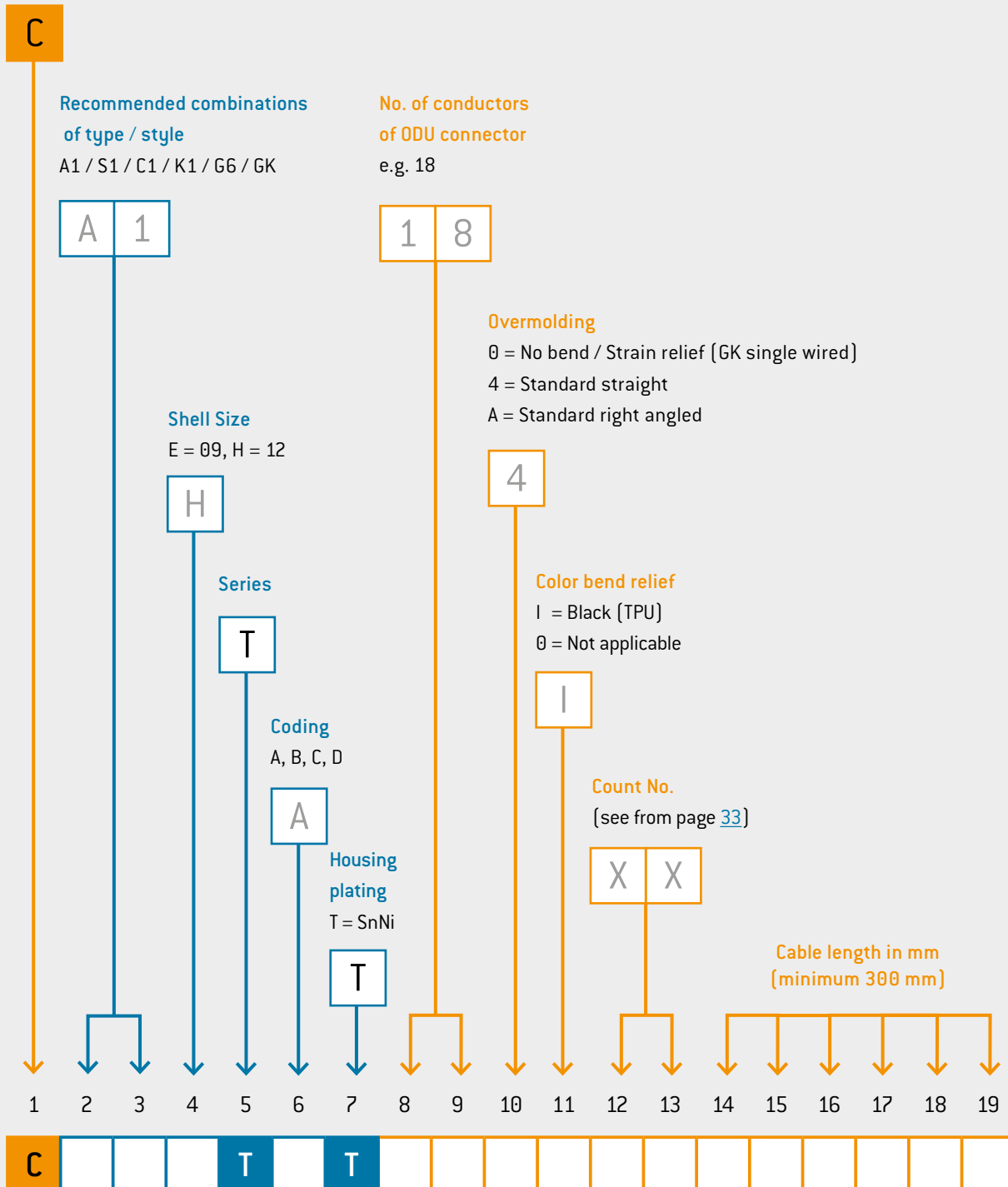

The digits 2-7 must be transferred from the connector part number.

CABLE SPECIFICATIONS

TECHNICAL DATA

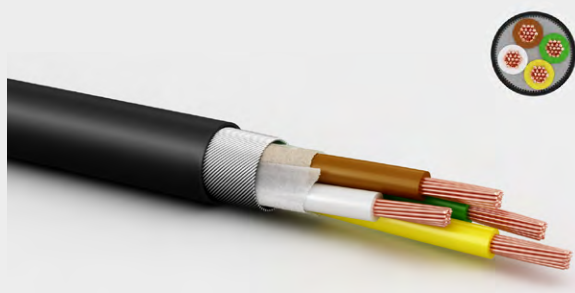

MULTI-CONDUCTOR CABLES PUR – SHIELDED

D-UL / cUL – STYLE 20233/10042

Conductor	bare copper acc. to EN 13602:2013
Insulation	TPE (12Y) thermoplastic compound (core) PUR – (11Y) / UL-AWM758 (jacket)
Shielding	spiral shield; tinned copper
Temperature range in motion	–40 up to +80 °C
Temperature range at rest	–50 up to +80 °C
Spark test	1,500 V
Operating voltage UL	300 V



SINGLE WIRE PVC

UL-STYLE 1061 / 10002 | UL-STYLE 1007 / 1569 | UL-STYLE 1015

Conductor	TPC – tin plated copper acc. to EN 13602:2013
Insulation	UL-PVC semi-rigid (UL-Style 1061 / 10002) UL-PVC 105 °C (UL-Style 1007 / 1569 & 1015)
Temperature range in motion	–10 up to +105 °C
Temperature range at rest	–30 up to +105 °C
Spark test	2,500 V (UL-Style 1061 / 10002) 3,000 V (UL-Style 1007 / 1569) 6,000 V (UL-Style 1015)
Operating voltage	300 V (UL-Style 1061 / 10002 & 1007 / 1569) 600 V (UL-Style 1015)

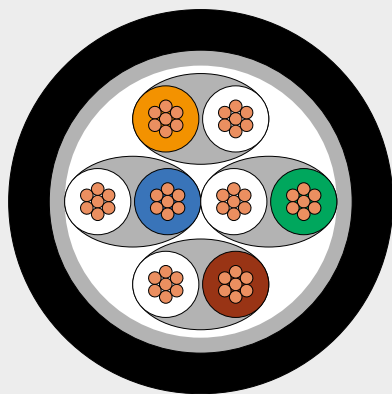

PATCH CABLES – PRE-ASSEMBLED

TECHNICAL DATA

Conductor:	Bare copper wire, Ø 0.46 mm AWG 27 / 7
Isolation:	LSZH Ø 5.80 mm (jacket) / PVC PE Ø 1.02 mm (core)
Shielding:	Tinned copper braid
Particle intrusion:	IP2X
Water / Submerge:	IPX0
Ambient temperature:	–40 °C to +70 °C
Halogen-free:	IEC 60754-2
Flame retardant:	IEC 60332-1; UL 444 CM
Transmission characteristics:	suitable for up to 10 Gigabit Ethernet Category 6A: ISO/IEC 11801; DIN EN 50173-1 :2018-10 Class EA: ISO/IEC 11801; DIN EN 50173-1 :2018-10 Category 6A: ANSI/TIA/EIA-568-C.2
UL listed:	E244889



OVERMOLDING

TECHNICAL DATA

Material:	TPU
Color:	Black
Operating temperature:	–40 °C to +85 °C
Flamability:	UL 94 (HB)

CABLE ASSEMBLY FOR STRAIGHT VERSIONS

OVERVIEW

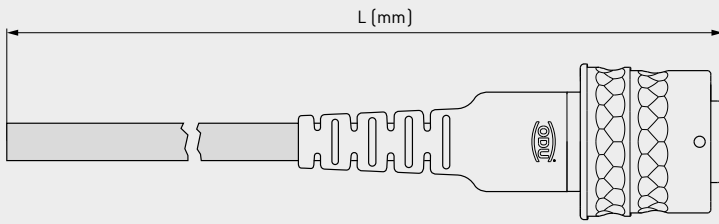

Push-pull plug (Style 1) overmolded..... [33](#)

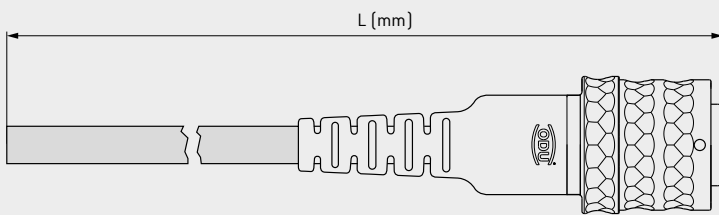

Break-away plug (Style 1) overmolded..... [35](#)

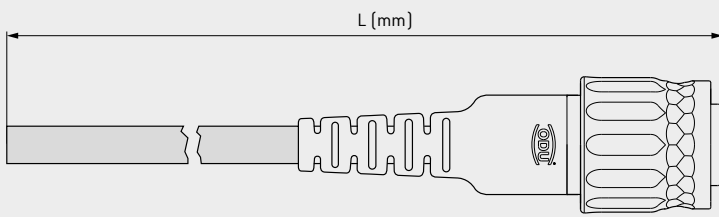

Threaded plug (Style 1) overmolded..... [37](#)

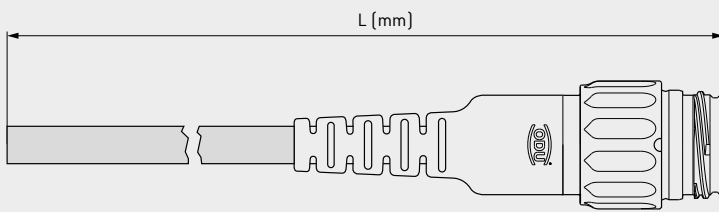

In-line receptacle (Style 1) overmolded..... [39](#)

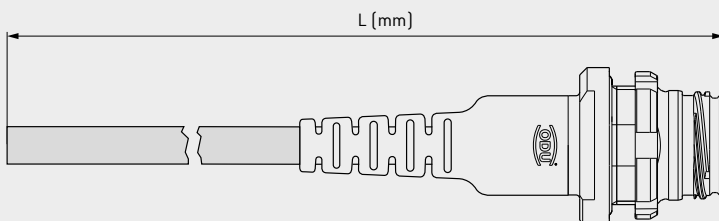

Panel mount receptacle (Style 6) overmolded..... [41](#)

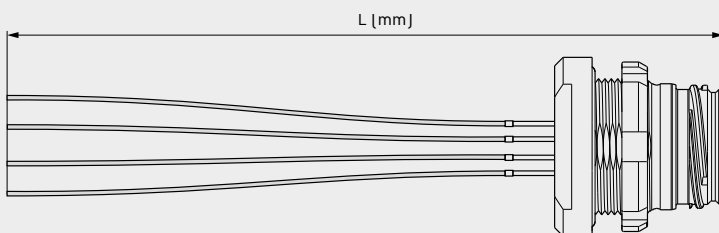

Panel mount receptacle (Style K) single wires..... [43](#)

CABLE ASSEMBLY FOR RIGHT ANGLED VERSIONS

OVERVIEW

	<p>Push-pull plug (Style 1) overmolded 33</p>
	<p>Break-away plug (Style 1) overmolded 35</p>
	<p>Threaded plug (Style 1) overmolded 37</p>
	<p>In-Line receptacle (Style 1) overmolded 39</p>
	<p>Panel mount receptacle (Style 6) overmolded 41</p>

CABLE ASSEMBLY ETHERNET STRAIGHT VERSION

300 – 25,000 mm

Cable assembly

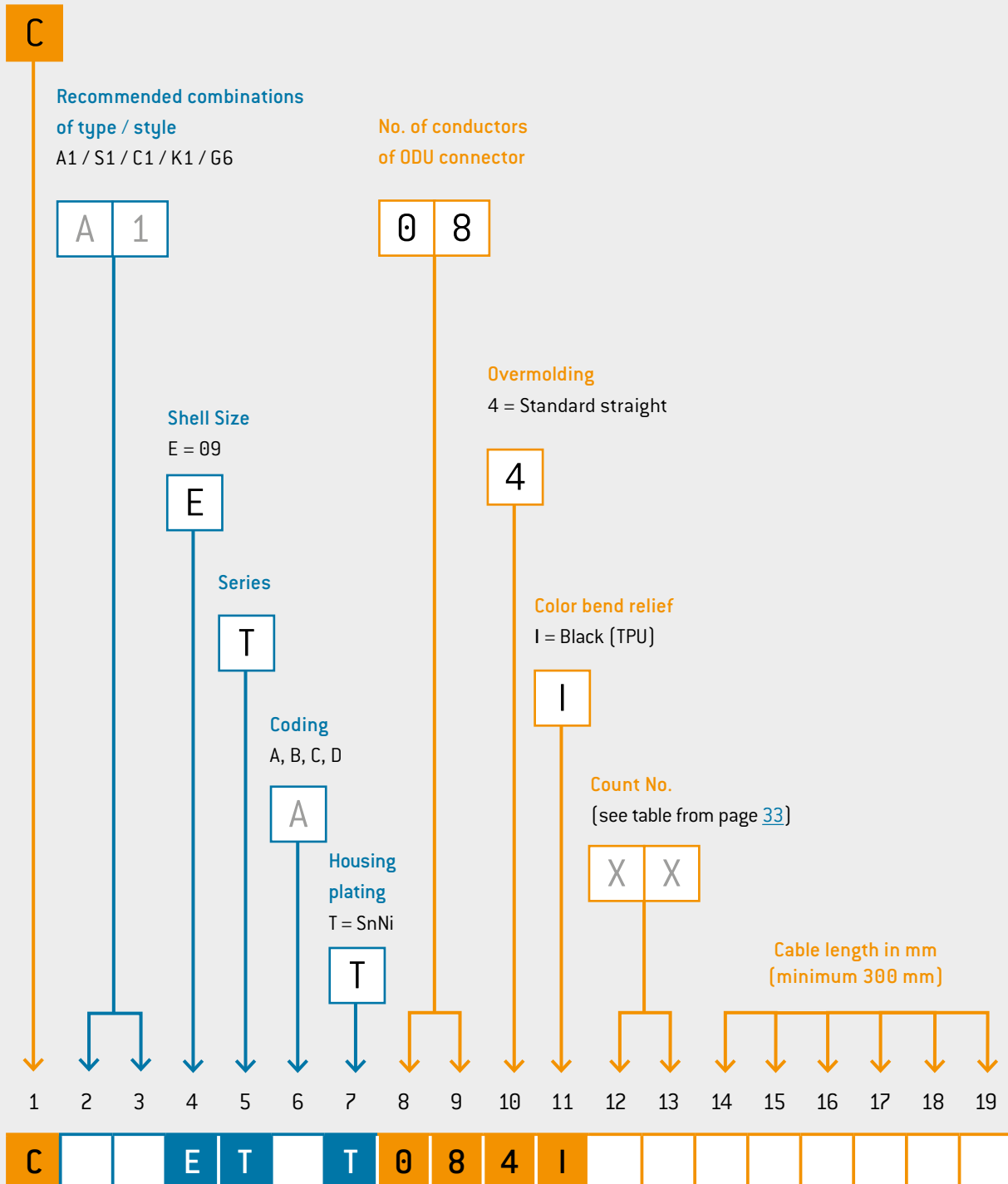

The digits 2-7 must be transferred from the connector part number.

CABLE ASSEMBLY ETHERNET STRAIGHT VERSION

300 – 25,000 mm

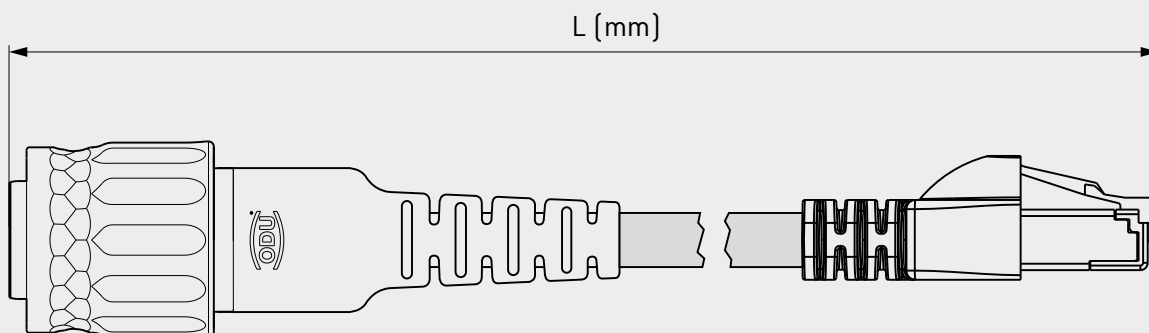

1 st side	Count-No. pin version	Count-No. socket version	2 nd side
S1*	ZJ*	ZI	RJ45-plug Ethernet Type CAT 5 up to 1 Gbit ¹
A1*	ZJ*	ZI	
C1*	ZJ*	ZI	
K1*	ZJ	ZI*	
G6*	ZJ	ZI*	

* Standard interface: Plug with pins / receptacle with sockets

¹ ISO / IEC 11801:2017, further information on request

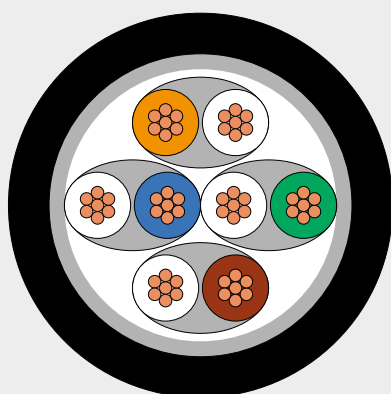

PATCH CABLES – PRE-ASSEMBLED

TECHNICAL DATA

Conductor:	Bare copper wire, Ø 0.46 mm AWG 27 / 7
Isolation:	LSZH Ø 5.80 mm [jacket] / PVC PE Ø 1.02 mm [core]
Shielding:	Tinned copper braid
Particle intrusion:	IP2X
Water / Submerge:	IPX0
Ambient temperature:	-40 °C to +70 °C
Halogen-free:	IEC 60754-2:2011
Flame retardant:	IEC 60332-1; UL 444 CM
Transmission characteristics:	Suitable for 10 Gigabit Ethernet Category 6A: ISO/IEC 11801; DIN EN 50173-1:2018-10 Class EA: ISO/IEC 11801; DIN EN 50173-1:2018-10 Category 6A: ANSI/TIA/EIA-568-C.2
UL listed:	E244889

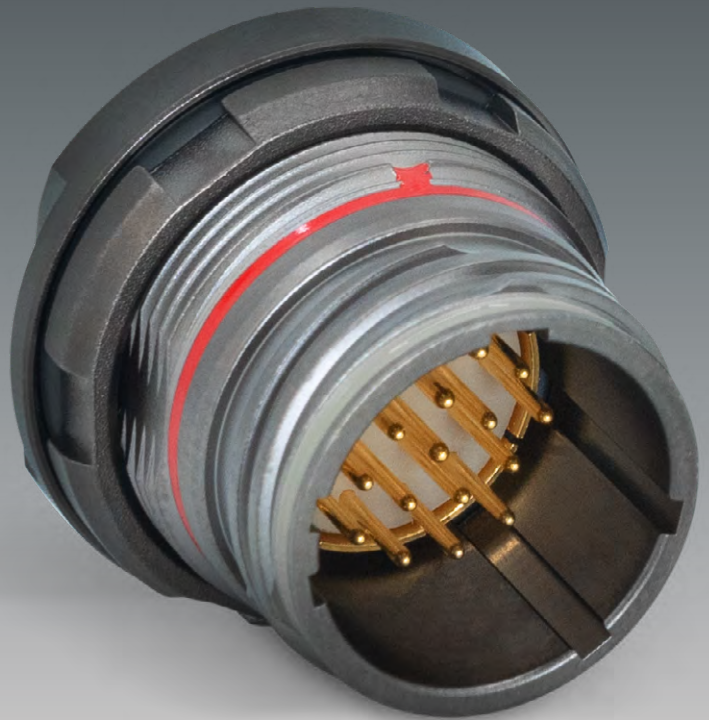

ODU AMC® SERIES T



ODU AMC[®] SERIES T

Summary ODU AMC [®] Series T	30
Plugs and cable assemblies	32
Receptacles and cable assemblies	38
Plugs with backshell terminations and cable assemblies	44
Receptacles with backshell terminations and cable assemblies	47
Contact inserts and PCB layouts	50

SUMMARY ODU AMC® SERIES T

The ODU AMC® Series T includes three compatible locking variants: push-pull, break-away or thread-lock. These connectors offer even greater robustness and density for all kinds of demanding applications. Choose the appropriate locking system, size, cable connection, insert and number of contacts to suit your requirements.

- Waterproof in accordance with MIL standard 810 up to 20 m
- Operating temperature range from –65 °C to +175 °C
- Sealed mechanical components, thus completely protected
- Highly flexible solution
- Suitable for MIL backshell and MIL crimp contacts
- Field assembly capability

PUSH-PULL PLUG P. [32](#)



BREAK-AWAY PLUG P. [34](#)



THREADED PLUG P. [36](#)



IN-LINE RECEPTACLE P. [38](#)



PANEL MOUNT RECEPTACLE P. [40](#)



PANEL MOUNT RECEPTACLE WITH PCB & SOLDER TERMINATION P. [42](#)



PUSH-PULL PLUG WITH BACKSHELL TERMINATION

P. 44



S B

BREAK-AWAY PLUG WITH BACKSHELL TERMINATION

P. 45



A B

THREADED PLUG WITH BACKSHELL TERMINATION

P. 46



C B

IN-LINE RECEPTACLE WITH BACKSHELL TERMINATION

P. 47



K B

PANEL MOUNT RECEPTACLE WITH BACKSHELL TERMINATION

P. 48



G B

PUSH-PULL PLUG

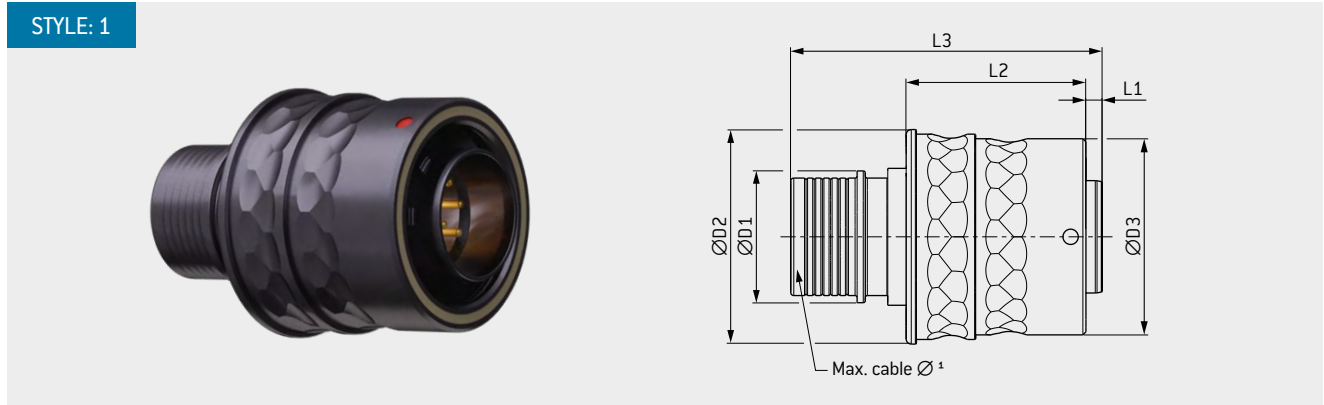

Shell size	L1 mm	L2 mm	L3 mm	D1 mm	D2 mm	D3 mm	Max. cable Ø in mm ¹
09	E	1.6	17.6	30.5	12.9	21.0	7.6
12	H	4.5	21.4	37.0	18.6	24.2	14.6

TECHNICAL DATA

- Technical data see page 74
- Contact configuration see page 50
- For assembly instructions please refer to our website: odu-connectors.com/downloads

- Accessories for cable termination (e.g. crimp sleeve or band it) must be ordered separately

¹ Only for variants with ODU Overmolding

² Water resistance 20 m / 120 min. The protection is only assured when crimp sleeve is potted during cable assembly according to ODU AMC® Series T assembly instructions. Operating temperature for 20 m solution from -65 °C up to +85 °C.

DELIVERY CONDITION

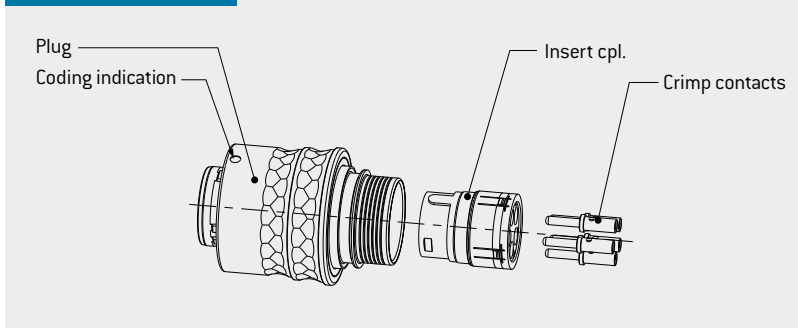

	Performance specifications – Plug in combination with		
	Receptacle style K see page 42	Receptacle style 6 / B see page 40 / 48	In-line receptacle see page 38
Vibration	Sine 30 g	Sine 30 g	Sine 30 g
Shock	300 g	300 g	300 g
Mating cycles	500	500	500
Operating High	+175 °C	+175 °C	+175 °C
Operating Low	-65 °C	-65 °C	-65 °C
Water Immersion ²	20 m / 120 min mated condition	20 m / 120 min mated condition	20 m / 120 min mated condition
Humidity	25 up to 65 °C / 90 – 98 % RH / 240 h	25 up to 65 °C / 90 – 98 % RH / 240 h	25 up to 65 °C / 90 – 98 % RH / 240 h
Salt Spray	96 h	96 h	96 h

Values in table refer to the connector only.

1 2 3 4 5 6 7 8 9 10 11 12 13 14 15 16 17 18 19
S 1 T A T 0 - N - 0 0 0 0

For support and customer specific solutions: sales@odu.de

CABLE ASSEMBLY – PUSH-PULL PLUG

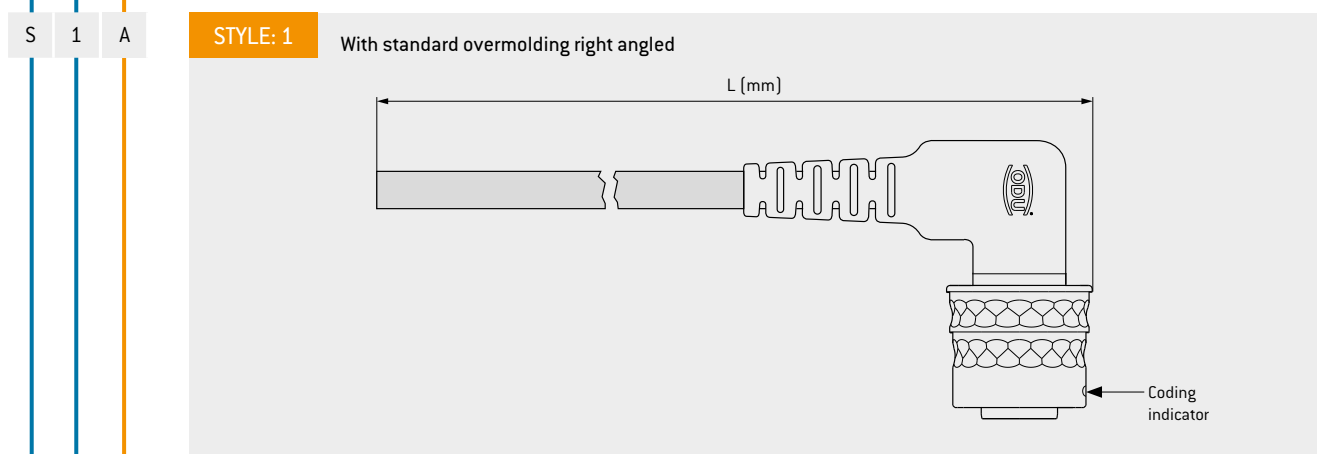
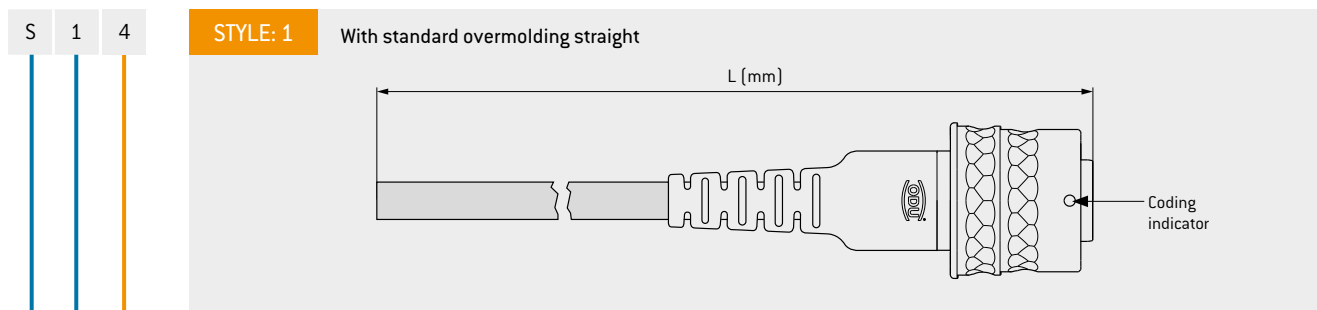

Shell size	Number of contacts	Contact	Multi conductor cable PUR shielded	Outer Cable Ø in mm	Wire-Ø in mm	AWG
9	8	Socket	ZX	5.60 ± 0.25	0.95 ± 0.10	26
9	8	Pin	ZZ	5.60 ± 0.25	0.95 ± 0.10	26
9	10	Socket	ZP	7.00 ± 0.25	1.30 ± 0.15	22
9	10	Pin	ZR	7.00 ± 0.25	1.30 ± 0.15	22
12	5	Socket	ZT	5.95 ± 0.20	1.50 ± 0.10	20
12	5	Pin	ZV	5.95 ± 0.20	1.50 ± 0.10	20
12	18	Socket	ZL	8.15 ± 0.25	1.30 ± 0.15	22
12	18	Pin	ZN	8.15 ± 0.25	1.30 ± 0.15	22

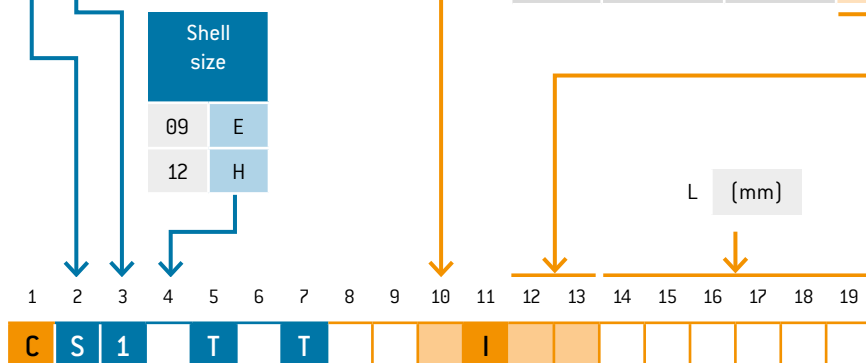

For support and customer specific solutions: sales@odu.de

BREAK-AWAY PLUG

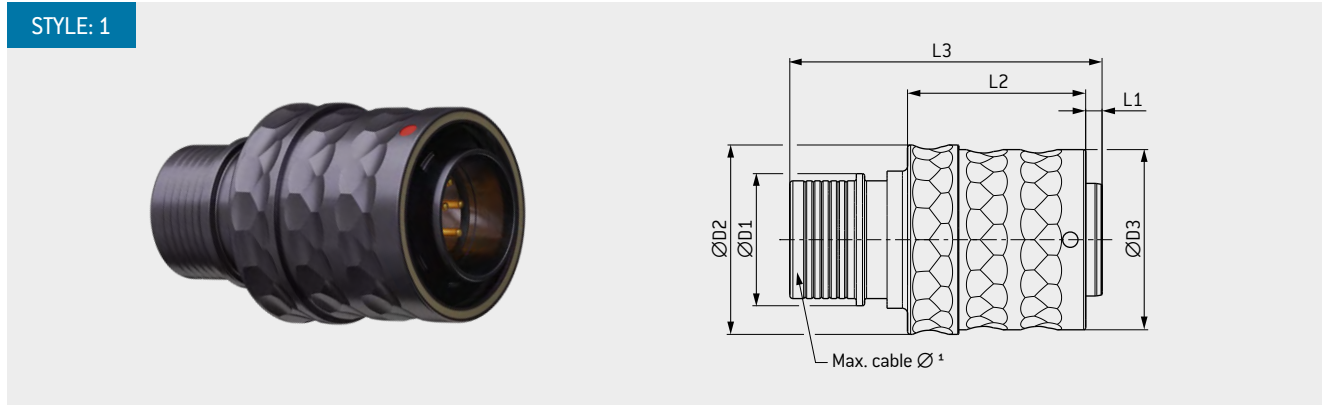

Shell size	L1 mm	L2 mm	L3 mm	D1 mm	D2 mm	D3 mm	Max. cable Ø in mm ¹
09	E	1.6	17.4	30.5	12.9	18.5	7.6
12	H	4.5	23.0	37.0	18.6	23.3	14.6

TECHNICAL DATA

- Technical data see page 74
- Contact configuration see page 50
- For assembly instructions please refer to our website: odu-connectors.com/downloads

- Accessories for cable termination (e.g. crimp sleeve or band it) must be ordered separately

¹ Only for variants with ODU Overmolding

² Water resistance 20 m / 120 min. The protection is only assured when crimp sleeve is potted during cable assembly according to ODU AMC® Series T assembly instructions. Operating temperature for 20 m solution from -65 °C up to +85 °C.

DELIVERY CONDITION

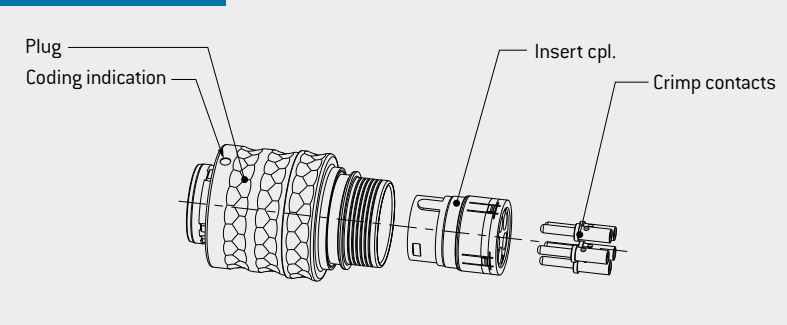

	Performance specifications – Plug in combination with		
	Receptacle style K see page 42	Receptacle style 6 / B see page 40 / 48	In-line receptacle see page 38
Vibration	Sine 20 g	Sine 20 g	Sine 20 g
Shock	100 g	100 g	100 g
Mating cycles	500	500	500
Operating High	+175 °C	+175 °C	+175 °C
Operating Low	-65 °C	-65 °C	-65 °C
Water Immersion ²	20 m / 120 min mated condition	20 m / 120 min mated condition	20 m / 120 min mated condition
Humidity	25 up to 65 °C / 90 – 98 % RH / 240 h	25 up to 65 °C / 90 – 98 % RH / 240 h	25 up to 65 °C / 90 – 98 % RH / 240 h
Salt Spray	96 h	96 h	96 h

Values in table refer to the connector only.

1 2 3 4 5 6 7 8 9 10 11 12 13 14 15 16 17 18 19

A	1	T		A	T	0	-						N	-	0	0	0	0
---	---	---	--	---	---	---	---	--	--	--	--	--	---	---	---	---	---	---

For support and customer specific solutions: sales@odu.de

CABLE ASSEMBLY – BREAK-AWAY PLUG

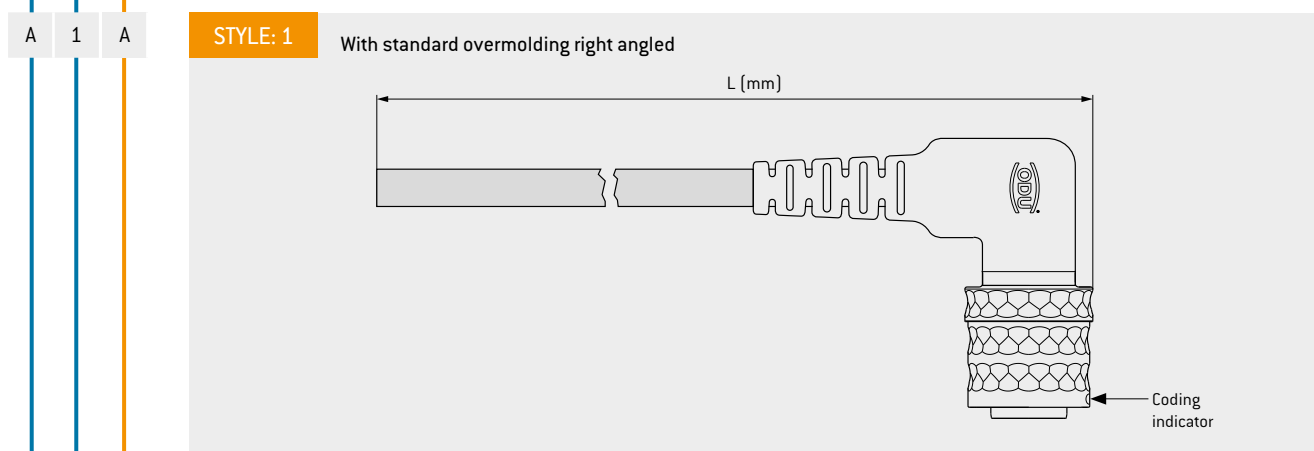
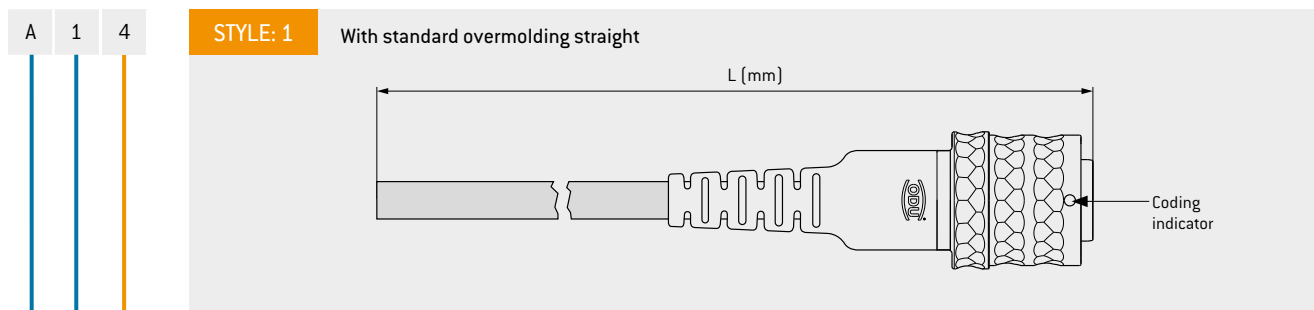

Shell size	Number of contacts	Contact	Multi conductor cable PUR shielded	Outer Cable Ø in mm	Wire-Ø in mm	AWG
9	8	Socket	ZX	5.60 ± 0.25	0.95 ± 0.10	26
9	8	Pin	ZZ	5.60 ± 0.25	0.95 ± 0.10	26
9	10	Socket	ZP	7.00 ± 0.25	1.30 ± 0.15	22
9	10	Pin	ZR	7.00 ± 0.25	1.30 ± 0.15	22
12	5	Socket	ZT	5.95 ± 0.20	1.50 ± 0.10	20
12	5	Pin	ZV	5.95 ± 0.20	1.50 ± 0.10	20
12	18	Socket	ZL	8.15 ± 0.25	1.30 ± 0.15	22
12	18	Pin	ZN	8.15 ± 0.25	1.30 ± 0.15	22

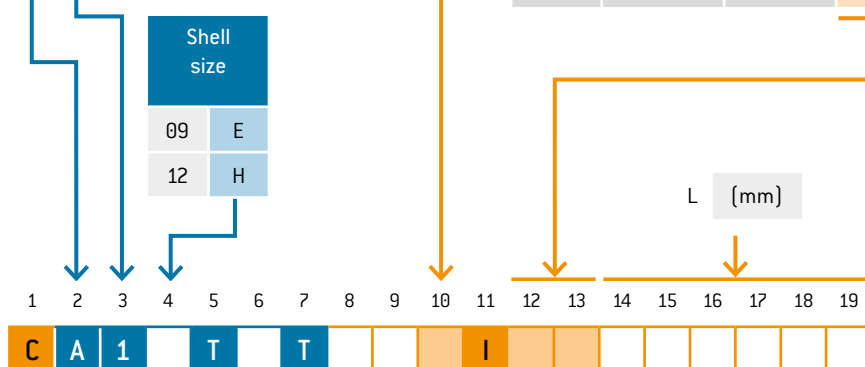

For support and customer specific solutions: sales@odu.de

THREADED PLUG

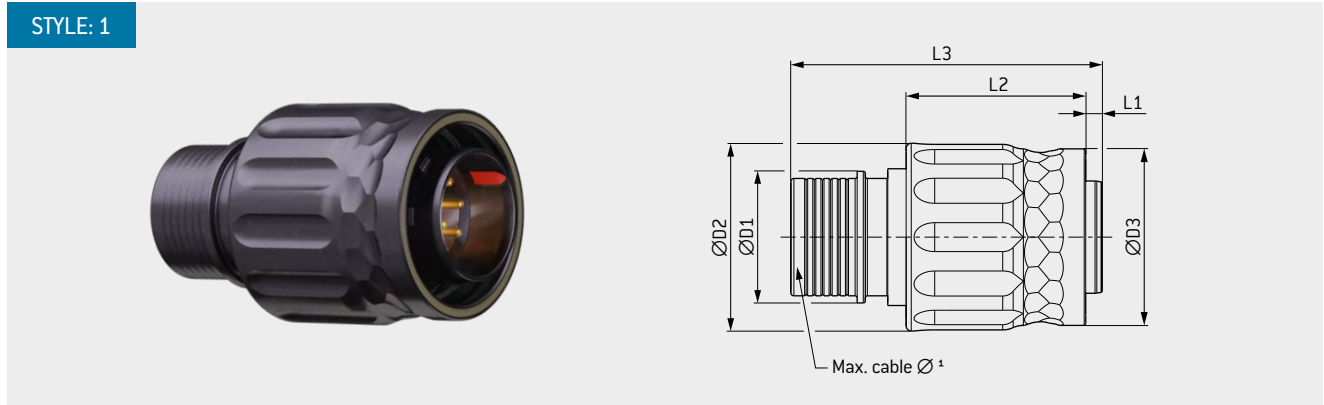

Shell size	L1 mm	L2 mm	L3 mm	D1 mm	D2 mm	D3 mm	Max. cable Ø in mm ¹
09	E	1.6	17.6	30.5	12.9	18.4	7.6
12	H	4.5	21.2	37.0	18.6	24.9	14.6

TECHNICAL DATA

- Technical data see page 74
- Contact configuration see page 50
- For assembly instructions please refer to our website: odu-connectors.com/downloads

- Accessories for cable termination (e.g. crimp sleeve or band it) must be ordered separately
- ¹ Only for variants with ODU Overmolding
- ² Water resistance 20 m / 120 min. The protection is only assured when crimp sleeve is potted during cable assembly according to ODU AMC® Series T assembly instructions. Operating temperature for 20 m solution from -65 °C up to +85 °C.

DELIVERY CONDITION

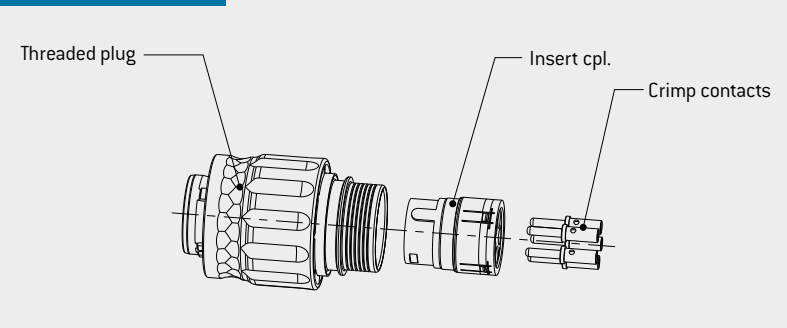

	Performance specifications – Plug in combination with		
	Receptacle style K see page 42	Receptacle style 6 / B see page 40 / 48	In-line receptacle see page 38
Vibration	Sine 30g, random 37.8 g	Sine 30g, random 37.8 g	Sine 30 g, random 37.8 g
Shock	300 g	300 g	300 g
Mating cycles	500	500	500
Operating High	+175 °C	+175 °C	+175 °C
Operating Low	-65 °C	-65 °C	-65 °C
Water Immersion ²	20 m / 120 min mated condition	20 m / 120 min mated condition	20 m / 120 min mated condition
Humidity	25 up to 65 °C / 90 – 98 % RH / 240 h	25 up to 65 °C / 90 – 98 % RH / 240 h	25 up to 65 °C / 90 – 98 % RH / 240 h
Salt Spray	96 h	96 h	96 h

Values in table refer to the connector only.

1 2 3 4 5 6 7 8 9 10 11 12 13 14 15 16 17 18 19

C 1 T A T Ø - N - Ø Ø Ø Ø

For support and customer specific solutions: sales@odu.de

CABLE ASSEMBLY – THREADED PLUG

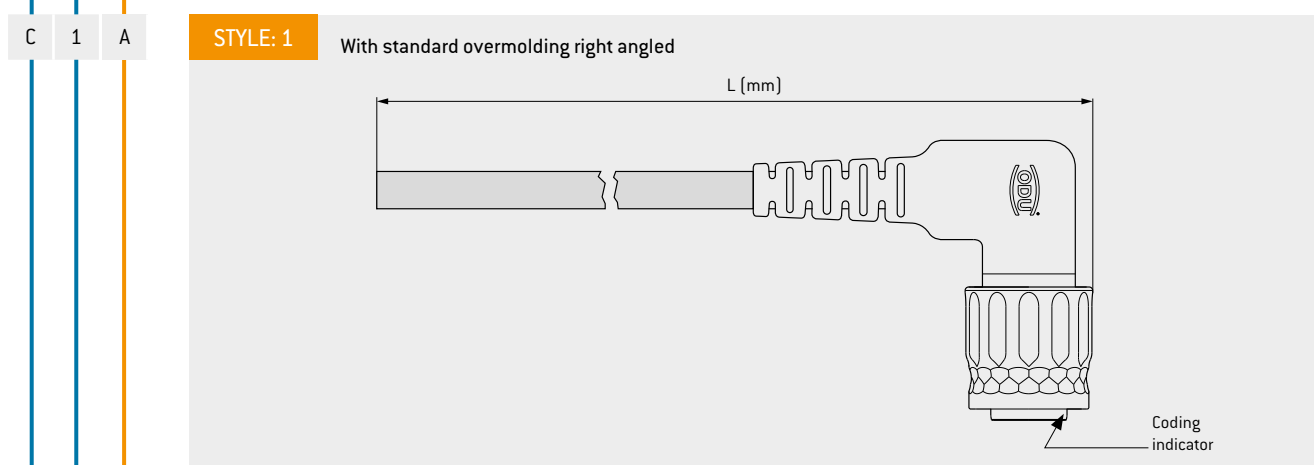
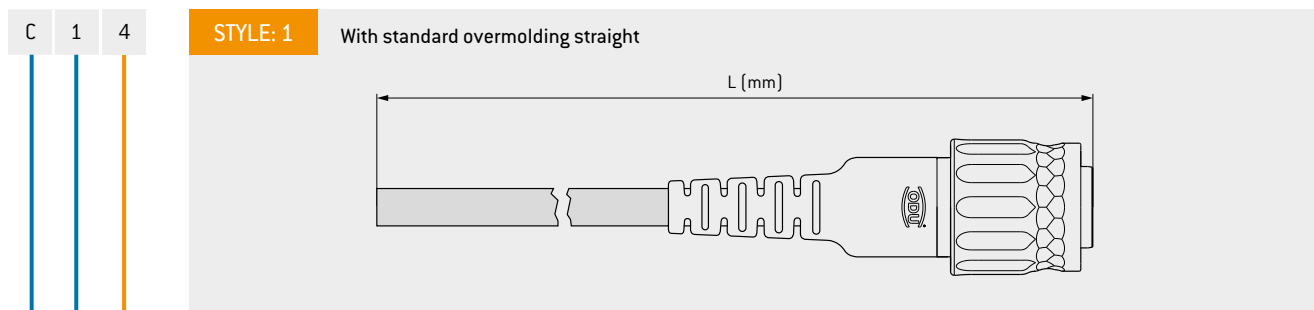

Shell size	Number of contacts	Contact	Multi conductor cable PUR shielded	Outer Cable Ø in mm	Wire-Ø in mm	AWG
9	8	Socket	ZX	5.60 ± 0.25	0.95 ± 0.10	26
9	8	Pin	ZZ	5.60 ± 0.25	0.95 ± 0.10	26
9	10	Socket	ZP	7.00 ± 0.25	1.30 ± 0.15	22
9	10	Pin	ZR	7.00 ± 0.25	1.30 ± 0.15	22
12	5	Socket	ZT	5.95 ± 0.20	1.50 ± 0.10	20
12	5	Pin	ZV	5.95 ± 0.20	1.50 ± 0.10	20
12	18	Socket	ZL	8.15 ± 0.25	1.30 ± 0.15	22
12	18	Pin	ZN	8.15 ± 0.25	1.30 ± 0.15	22

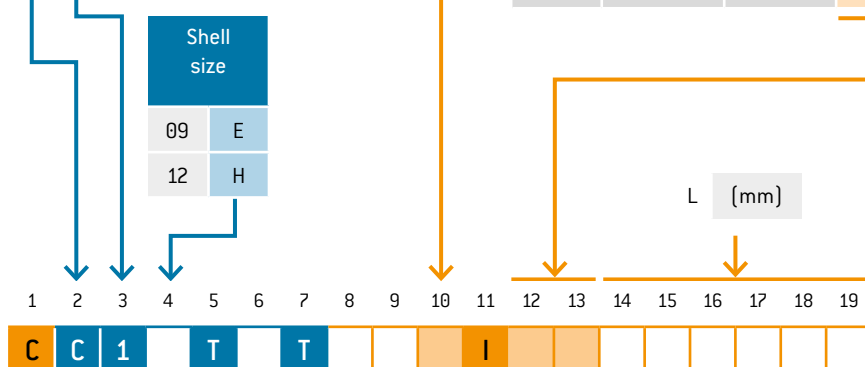

For support and customer specific solutions: sales@odu.de

IN-LINE RECEPTACLE

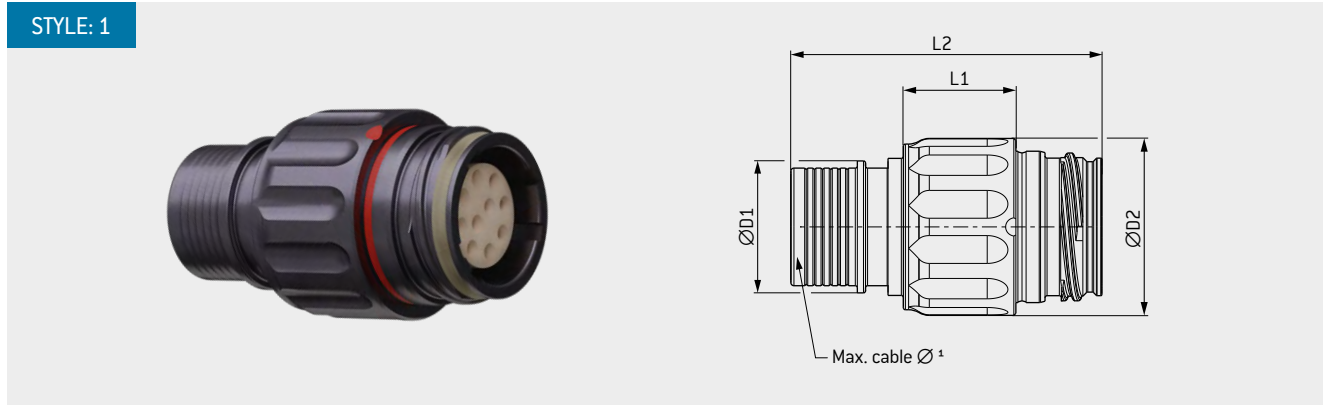

Shell size		L1 mm	L2 mm	D1 mm	D2 mm	Max. cable Ø in mm ¹
09	E	11.0	30.4	10.5	17.3	7.6
12	H	11.8	35.0	18.6	23.3	14.6

TECHNICAL DATA

- Technical data see page [74](#)
- Contact configuration see page [50](#)
- For assembly instructions please refer to our website: odu-connectors.com/downloads

- Accessories for cable termination (e.g. crimp sleeve or band it) must be ordered separately
- Nut driver for slotted nut see page [68](#)

¹ Only for variants with ODU Over-molding
² Water resistance 20 m / 120 min. The protection is only assured when crimp sleeve is potted during cable assembly according to ODU AMC® Series T assembly instructions. Operating temperature for 20 m solution from -65 °C up to +85 °C.

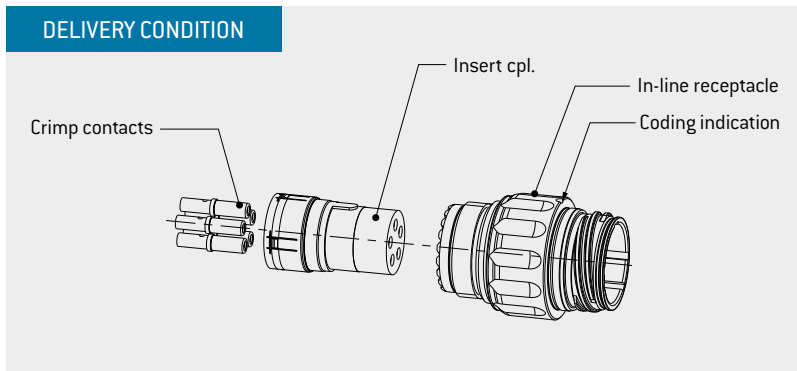

	Performance specifications – Plug in combination with		
	Push-pull plug see page 32	Break-away plug see page 34	Threaded plug see page 36
Vibration	Sine 30 g	Sine 20 g	Sine 30 g, random 37.8 g
Shock	300 g	100 g	300 g
Mating cycles	500	500	500
Operating High	+175 °C	+175 °C	+175 °C
Operating Low	-65 °C	-65 °C	-65 °C
Water Immersion	20 m / 120 min mated condition	20 m / 120 min mated condition	20 m / 120 min mated condition
Humidity	25 up to 65 °C / 90 – 98 % RH / 240 h	25 up to 65 °C / 90 – 98 % RH / 240 h	25 up to 65 °C / 90 – 98 % RH / 240 h
Salt Spray	96 h	96 h	96 h

Values in table refer to the connector only.

1 2 3 4 5 6 7 8 9 10 11 12 13 14 15 16 17 18 19

K 1 T A T 0 - N - 0 0 0 0

For support and customer specific solutions: sales@odu.de

CABLE ASSEMBLY – IN-LINE RECEPTACLE

K 1 4

STYLE: 1 With standard overmolding straight

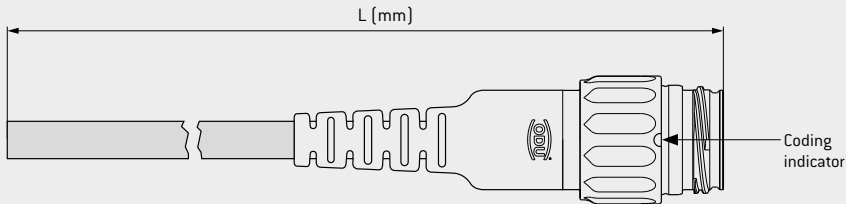

K 1 A

STYLE: 1 With standard overmolding right angled

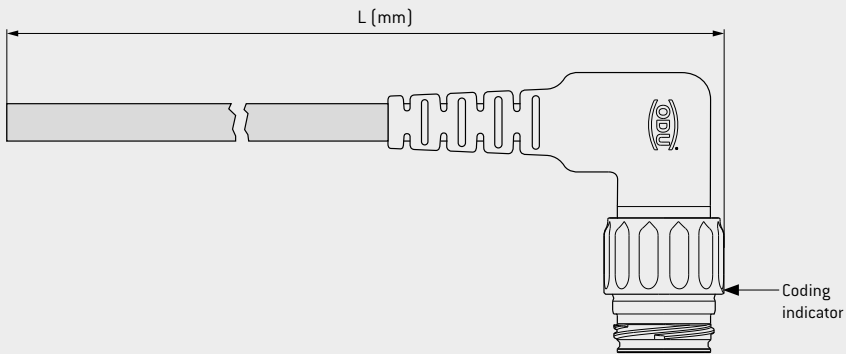

Shell size	Number of contacts	Contact	Multi conductor cable PUR shielded	Outer Cable Ø in mm	Wire-Ø in mm	AWG
9	8	Socket	ZX	5.60 ± 0.25	0.95 ± 0.10	26
9	8	Pin	ZZ	5.60 ± 0.25	0.95 ± 0.10	26
9	10	Socket	ZP	7.00 ± 0.25	1.30 ± 0.15	22
9	10	Pin	ZR	7.00 ± 0.25	1.30 ± 0.15	22
12	5	Socket	ZT	5.95 ± 0.20	1.50 ± 0.10	20
12	5	Pin	ZV	5.95 ± 0.20	1.50 ± 0.10	20
12	18	Socket	ZL	8.15 ± 0.25	1.30 ± 0.15	22
12	18	Pin	ZN	8.15 ± 0.25	1.30 ± 0.15	22

Shell size	
09	E
12	H

1 2 3 4 5 6 7 8 9 10 11 12 13 14 15 16 17 18 19

C K 1 T T I

For support and customer specific solutions: sales@odu.de

SERIES T

PANEL MOUNT RECEPTACLE

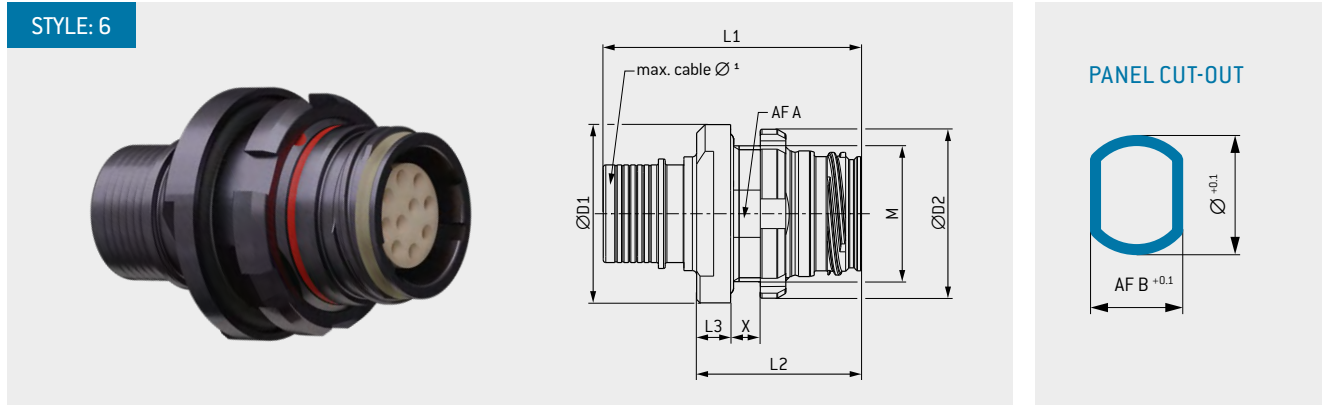

Shell size	L1 mm	L2 mm	L3 mm	X max.	D1 mm	D2 mm	M	AFA mm	Max. cable Ø in mm ¹	Panel cut out	
										AF B in mm	Ø in mm
09 E	30.4	19.4	4	3.5	21.0	19.9	M16 x 0.75	15.0	7.6	15.1	16.1
12 H	35	22.5	4.5	3.5	26.0	24.9	M21 x 1	19.5	14.6	19.6	21.1

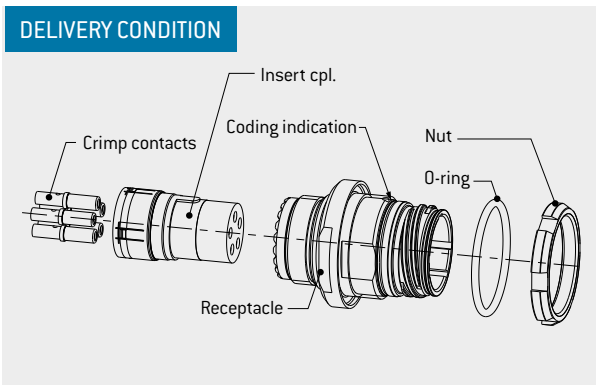

TECHNICAL DATA

- Technical data see page 74
 - Contact configuration see page 50
 - For assembly instructions please refer to our website: odu-connectors.com/downloads
 - Accessories for cable termination (e.g. crimp sleeve or band it) must be ordered separately
 - Nut driver for slotted nut see page 68
- ¹ Only for variants with ODU Over-molding
² Water resistance 20 m / 120 min. The protection is only assured when crimp sleeve is potted during cable assembly according to ODU AMC® Series T assembly instructions. Operating temperature for 20 m solution from -65 °C up to +85 °C.

	Performance specifications – Plug in combination with		
	Push-pull plug see page 32	Break-away plug see page 34	Threaded plug see page 36
Vibration	Sine 30 g	Sine 20 g	Sine 30 g, random 37.8 g
Shock	300 g	100 g	300 g
Mating cycles	500	500	500
Operating High	+175 °C	+175 °C	+175 °C
Operating Low	-65 °C	-65 °C	-65 °C
Water Immersion ²	20 m / 120 min mated condition	20 m / 120 min mated condition	20 m / 120 min mated condition
Humidity	25 up to 65 °C / 90 – 98 % RH / 240 h	25 up to 65 °C / 90 – 98 % RH / 240 h	25 up to 65 °C / 90 – 98 % RH / 240 h
Salt Spray	96 h	96 h	96 h

Values in table refer to the connector only.

1 2 3 4 5 6 7 8 9 10 11 12 13 14 15 16 17 18 19
G 6 T A T 0 - N - 0 0 0 0

For support and customer specific solutions: sales@odu.de

CABLE ASSEMBLY – PANEL MOUNT RECEPTACLE

G 6 4

STYLE: 6 With standard overmolding straight

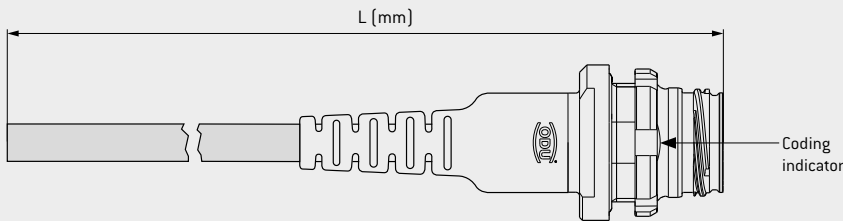

G 6 A

STYLE: 6 With standard overmolding right angled

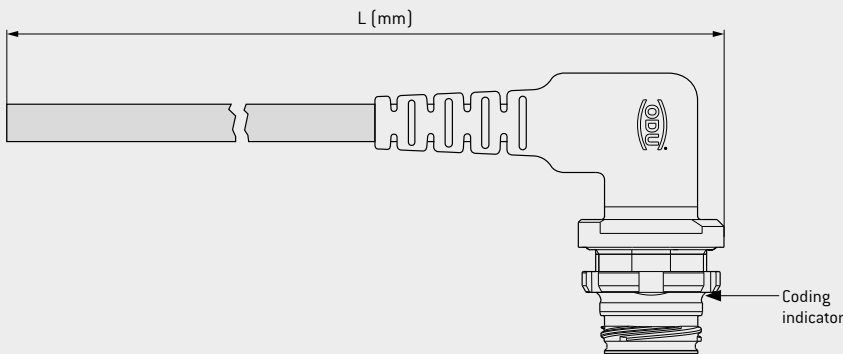

Shell size	Number of contacts	Contact	Multi conductor cable PUR shielded	Outer Cable Ø in mm	Wire-Ø in mm	AWG
9	8	Socket	ZX	5.60 ± 0.25	0.95 ± 0.10	26
9	8	Pin	ZZ	5.60 ± 0.25	0.95 ± 0.10	26
9	10	Socket	ZP	7.00 ± 0.25	1.30 ± 0.15	22
9	10	Pin	ZR	7.00 ± 0.25	1.30 ± 0.15	22
12	5	Socket	ZT	5.95 ± 0.20	1.50 ± 0.10	20
12	5	Pin	ZV	5.95 ± 0.20	1.50 ± 0.10	20
12	18	Socket	ZL	8.15 ± 0.25	1.30 ± 0.15	22
12	18	Pin	ZN	8.15 ± 0.25	1.30 ± 0.15	22

Shell size	
09	E
12	H

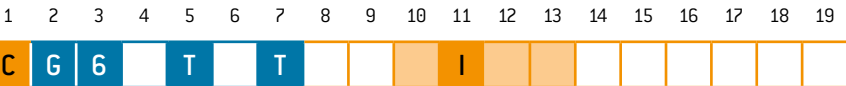

For support and customer specific solutions: sales@odu.de

SERIES T

PANEL MOUNT RECEPTACLE WITH PCB & SOLDER TERMINATION

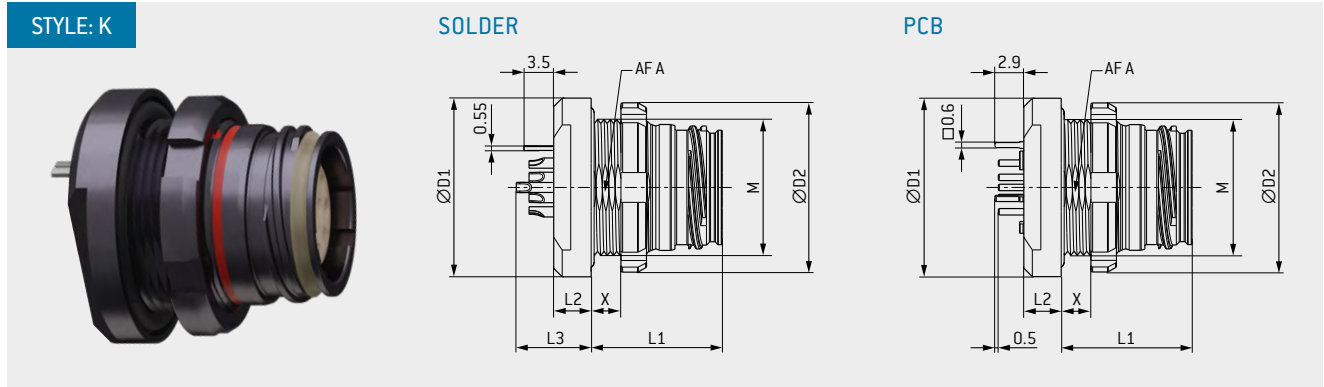

Shell size	L1 mm	L2 mm	L3 mm	x max.	D1 mm	D2 mm	M	AF A mm	Max. cable Ø in mm
09	E	15.4	4.4	7.3	3.5	21.0	M16 x 0.7	15.0	7.6
12	H	18.0	4.5	10.4	3.5	26.0	M21 x 1.0	19.5	14.6

Panel cut out	
AF B in mm	Ø in mm
15.1	16.1
19.6	21.1

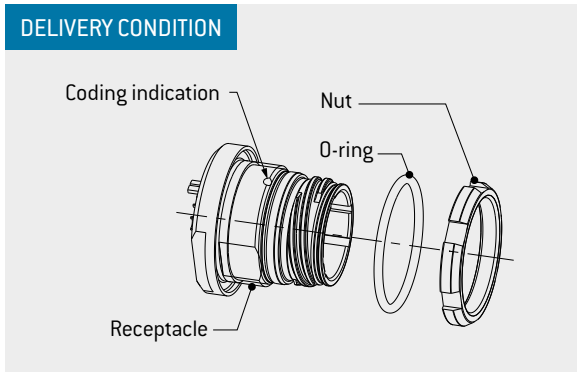

TECHNICAL DATA

- Technical data see page 74
 - Contact configuration see page 50
 - For assembly instructions please refer to our website: odu-connectors.com/downloads
 - Nut driver for slotted nut see page 68
- ¹ Water resistance 20 m / 120 min. The protection is only assured when crimp sleeve is potted during cable assembly according to ODU AMC® Series T assembly instructions. Operating temperature for 20 m solution from -65 °C up to +85 °C.

	Performance specifications – Plug in combination with		
	Push-pull plug see page 32	Break-away plug see page 34	Threaded plug see page 36
Vibration	Sine 30 g	Sine 20 g	Sine 30 g, random 37.8 g
Shock	300 g	100 g	300 g
Mating cycles	500	500	500
Operating High	+175 °C	+175 °C	+175 °C
Operating Low	-65 °C	-65 °C	-65 °C
Water Immersion ¹	1 m 120 min	1 m 120 min	1 m 120 min
Humidity	25 up to 65 °C / 90 – 98 % RH / 240 h	25 up to 65 °C / 90 – 98 % RH / 240 h	25 up to 65 °C / 90 – 98 % RH / 240 h
Salt Spray	96 h	96 h	96 h

Values in table refer to the connector only.

1 2 3 4 5 6 7 8 9 10 11 12 13 14 15 16 17 18 19

G K T A T O - N - 0 0 0 0

For support and customer specific solutions: sales@odu.de

PANEL MOUNT RECEPTACLE WITH SINGLE WIRES

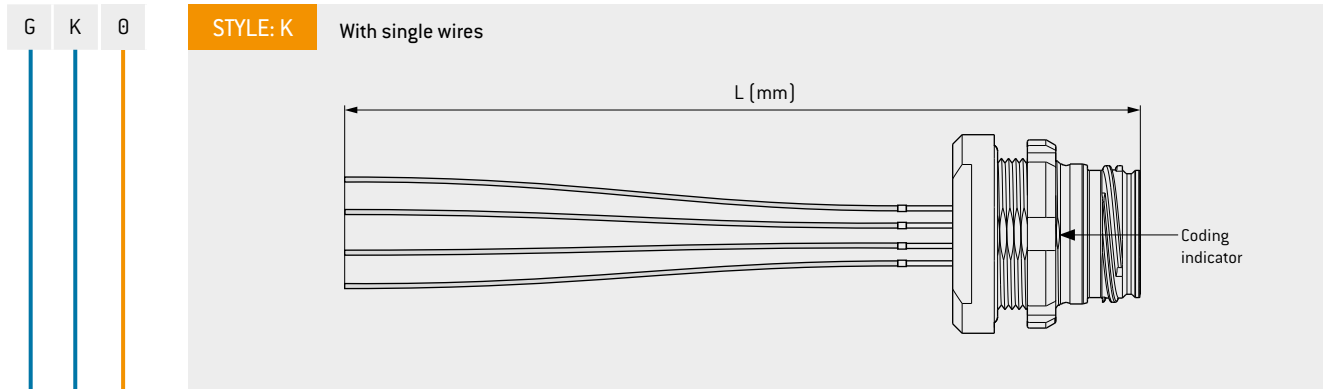

Shell size	Number of contacts	Contact	Single wires	Wire-Ø in mm	AWG
9	8	Socket	ZY	1.30 ± 0.05	22
9	8	Pin	ZW	1.30 ± 0.05	22
9	10	Socket	ZU	1.30 ± 0.05	22
9	10	Pin	ZS	1.30 ± 0.05	22
12	5	Socket	ZQ	2.50 ± 0.10	16
12	5	Pin	ZO	2.50 ± 0.10	16
12	18	Socket	ZM	1.30 ± 0.05	22
12	18	Pin	ZK	1.30 ± 0.05	22

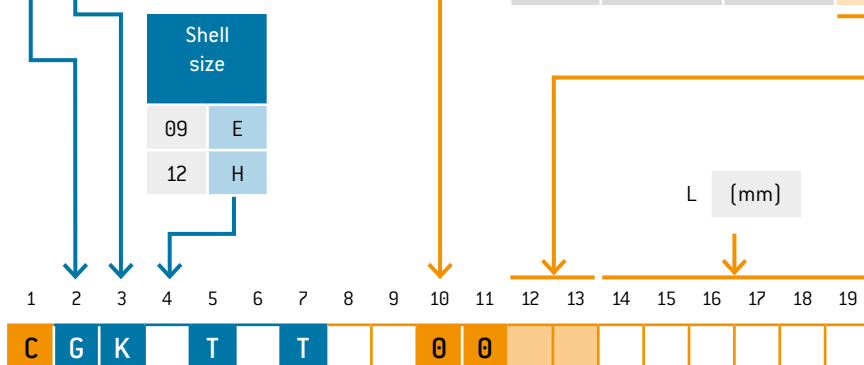

For support and customer specific solutions: sales@odu.de

PUSH-PULL PLUG WITH BACKSHELL TERMINATION

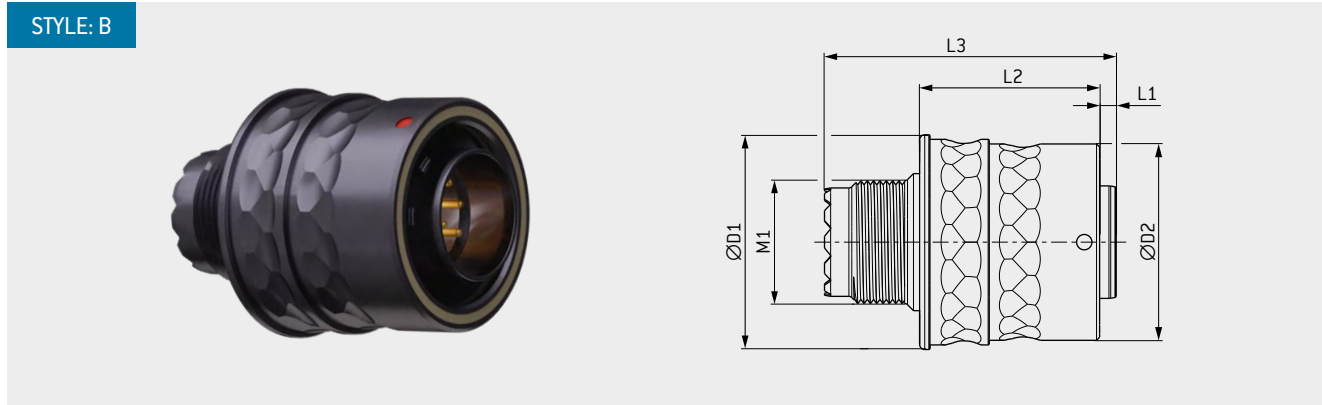

Shell size		L1 mm	L2 mm	L3 mm	D1 mm	D2 mm	M1 ¹
09	E	1.6	17.6	28.5	21.0	19.2	M12 x 1
12	H	4.5	21.4	35.0	26.0	24.2	M18 x 1

TECHNICAL DATA

- Technical data see page 74
- Contact configuration see page 50
- For assembly instructions please refer to our website: odu-connectors.com/downloads

- Accessories for cable termination (e.g. backshell or band-it) must be ordered separately
- ¹ Accessory thread according to MIL-DTL-38999 Series III, for shell size see page 56

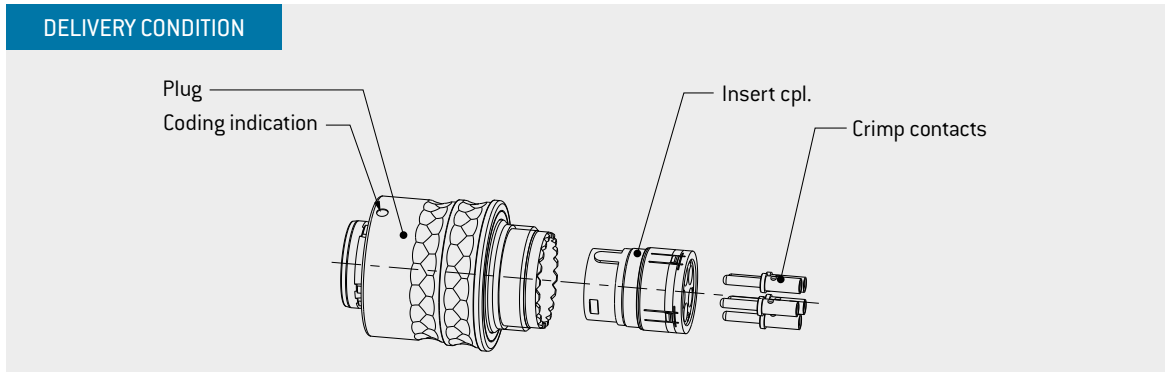

	Performance specifications – Plug in combination with		
	Receptacle style K see page 42	Receptacle style 6 / B see page 40 / 48	In-line receptacle see page 38
Vibration	Sine 30 g	Sine 30 g	Sine 30 g
Shock	300 g	300 g	300 g
Mating cycles	500	500	500
Operating high	+175 °C	+175 °C	+175 °C
Operating low	-65 °C	-65 °C	-65 °C
Water immersion	1 m 120 min	1 m 120 min	1 m 120 min
Humidity	25 up to 65 °C / 90 – 98 % RH / 240 h	25 up to 65 °C / 90 – 98 % RH / 240 h	25 up to 65 °C / 90 – 98 % RH / 240 h
Salt spray	96 h	96 h	96 h

Values in table refer to the connector only.

1 2 3 4 5 6 7 8 9 10 11 12 13 14 15 16 17 18 19

S B T A T O - N - 0 0 0 0

For support and customer specific solutions: sales@odu.de

BREAK-AWAY PLUG WITH BACKSHELL TERMINATION

STYLE: B

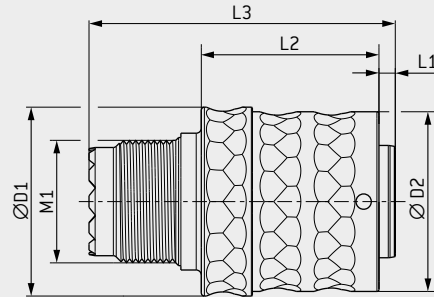

Shell size		L1 mm	L2 mm	L3 mm	D1 mm	D2 mm	M1 ¹
09	E	1.6	17.4	30.0	18.5	17.6	12 x 1
12	H	4.5	23.0	35.0	24.2	23.3	18 x 1

TECHNICAL DATA

- Technical data see page 74
- Contact configuration see page 50
- For assembly instructions please refer to our website: odu-connectors.com/downloads

- Accessories for cable termination (e.g. backshell or band-it) must be ordered separately
- ¹ Accessory thread according to MIL-DTL-38999 Series III, for shell size see page 56

DELIVERY CONDITION

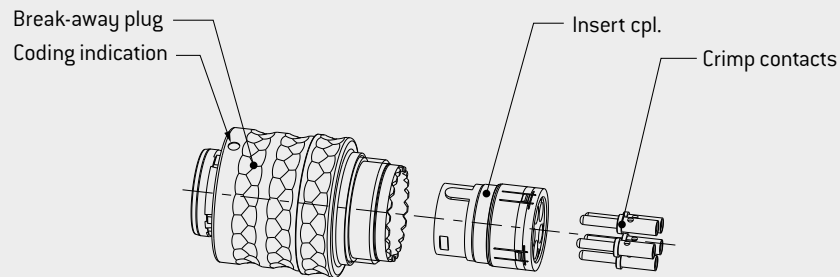

	Performance specifications – Plug in combination with		
	Receptacle style K see page 42	Receptacle style 6 see page 40	In-line receptacle see page 38
Vibration	Sine 20 g	Sine 20 g	Sine 20 g
Shock	100 g	100 g	100 g
Mating cycles	500	500	500
Operating high	+175 °C	+175 °C	+175 °C
Operating low	-65 °C	-65 °C	-65 °C
Water immersion	1m 120 min	1m 120 min	1m 120 min
Humidity	25 up to 65 °C / 90–98 % RH / 240 h	25 up to 65 °C / 90–98 % RH / 240 h	25 up to 65 °C / 90–98 % RH / 240 h
Salt spray	96h	96h	96h

Values in table refer to the connector only.

1 2 3 4 5 6 7 8 9 10 11 12 13 14 15 16 17 18 19

A B T A T 0 - N - 0 0 0 0

For support and customer specific solutions: sales@odu.de

THREADED PLUG WITH BACKSHELL TERMINATION

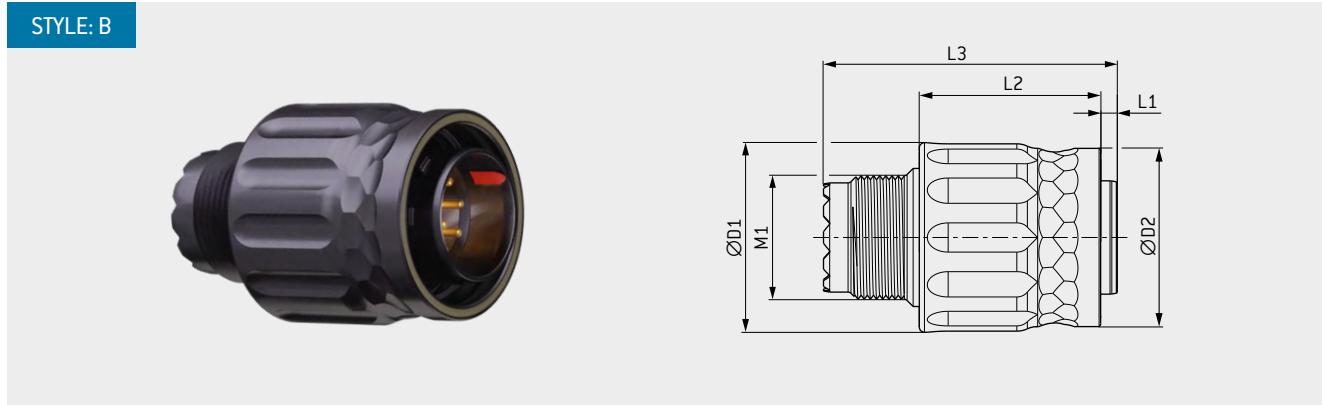

Shell size		L1 mm	L2 mm	L3 mm	D1 mm	D2 mm	M1 ¹
09	E	1.6	17.6	28.5	18.4	17.3	12 x 1
12	H	4.5	21.2	35.0	24.9	23.3	18 x 1

TECHNICAL DATA

- Technical data see page [74](#)
- Contact configuration see page [50](#)
- For assembly instructions please refer to our website: odu-connectors.com/downloads

- Accessories for cable termination (e.g. backshell or band-it) must be ordered separately
- ¹ Accessory thread according to MIL-DTL-38999 Series III, for shell size see page [56](#)

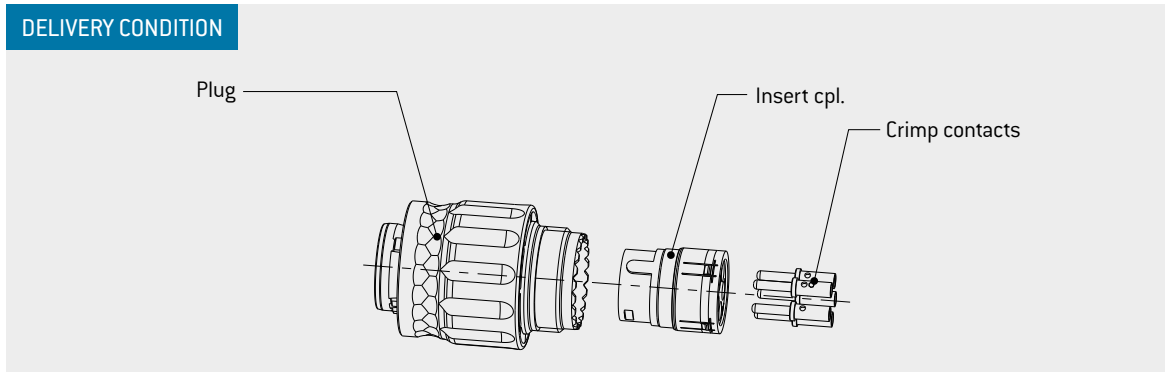

	Performance specifications – Plug in combination with		
	Receptacle style K see page 42	Receptacle style 6 / B see page 40 / 48	In-line receptacle see page 38
Vibration	Sine 30 g, random 37.8 g	Sine 30 g, random 37.8 g	Sine 30 g, random 37.8 g
Shock	300 g	300 g	300 g
Mating cycles	500	500	500
Operating high	+175 °C	+175 °C	+175 °C
Operating low	-65 °C	-65 °C	-65 °C
Water immersion	1 m 120 min	1 m 120 min	1 m 120 min
Humidity	25 up to 65 °C / 90 – 98 % RH / 240 h	25 up to 65 °C / 90 – 98 % RH / 240 h	25 up to 65 °C / 90 – 98 % RH / 240 h
Salt spray	96 h	96 h	96 h

Values in table refer to the connector only.

1 2 3 4 5 6 7 8 9 10 11 12 13 14 15 16 17 18 19

C B T A T Ø - N - Ø Ø Ø Ø

For support and customer specific solutions: sales@odu.de

IN-LINE RECEPTACLE WITH BACKSHELL TERMINATION

STYLE: B

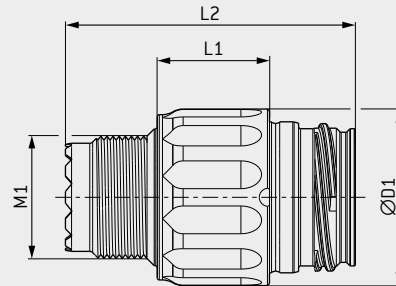

Shell size		L1 mm	L2 mm	D1 mm	M1 ¹
09	E	11.0	28.4	17.3	12 x 1
12	H	11.8	33.0	18.6	18 x 1

TECHNICAL DATA

- Technical data see page [74](#)
- Contact configuration see page [50](#)
- For assembly instructions please refer to our website: odu-connectors.com/downloads

- Accessories for cable termination (e.g. backshell or band-it) must be ordered separately

¹ Accessory thread according to MIL-DTL-38999 Series III, for shell size see page [56](#)

DELIVERY CONDITION

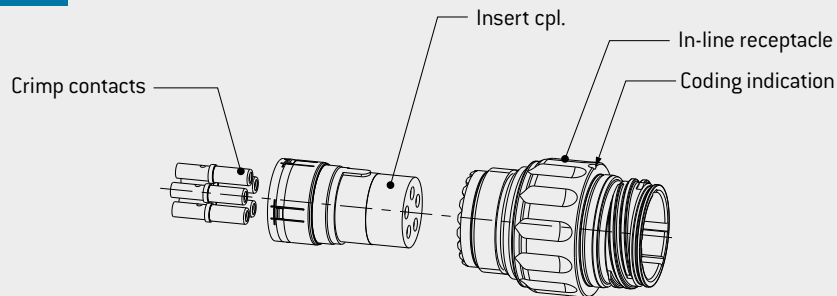

	Performance specifications – Plug in combination with		
	Push-pull plug see page 32	Break-away plug see page 34	Threaded plug see page 36
Vibration	Sine 30 g	Sine 20 g	Sine 30 g, random 37.8 g
Shock	300 g	100 g	300 g
Mating cycles	500	500	500
Operating high	+175 °C	+175 °C	+175 °C
Operating low	-65 °C	-65 °C	-65 °C
Water immersion	1 m 120 min	1 m 120 min	1 m 120 min
Humidity	25 up to 65 °C / 90 – 98 % RH / 240 h	25 up to 65 °C / 90 – 98 % RH / 240 h	25 up to 65 °C / 90 – 98 % RH / 240 h
Salt spray	96 h	96 h	96 h

Values in table refer to the connector only.

1 2 3 4 5 6 7 8 9 10 11 12 13 14 15 16 17 18 19

K B T A T 0 - N - 0 0 0 0

For support and customer specific solutions: sales@odu.de

PANEL MOUNT RECEPTACLE WITH BACKSHELL TERMINATION

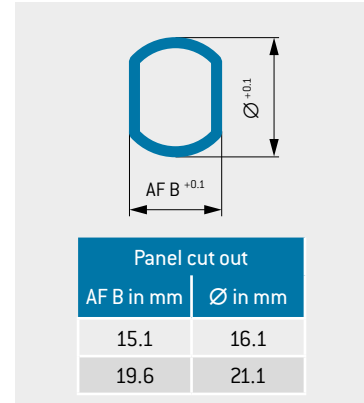
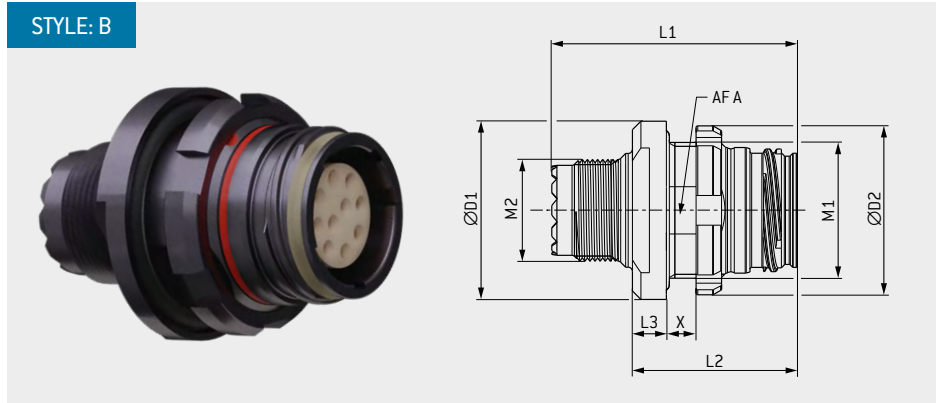

Shell size		L1 mm	L2 mm	L3 mm	x max.	D1 mm	D2 mm	M1	M2	AF A mm
09	E	28.9	19.4	4	3.5	21.0	19.9	16 x 0.75	12 x 1	15.0
12	H	33.0	22.5	4.5	3.5	26.0	24.9	21 x 1	18 x 1	19.5

TECHNICAL DATA

- Technical data see page 74
 - Contact configuration see page 50
 - For assembly instructions please refer to our website: odu-connectors.com/downloads
 - Accessories for cable termination (e.g. backshell or band-it) must be ordered separately
 - Nut driver for slotted nut see page 68
 - Accessory thread according to MIL-DTL-38999 Series III, for shell size see page 56
- ⁴ Water resistance 20 m / 120 min.
The protection is only assured when crimp sleeve is potted during cable assembly according to ODU AMC® Series T assembly instructions.
Operating temperature for 20 m solution from -65 °C up to +85 °C.

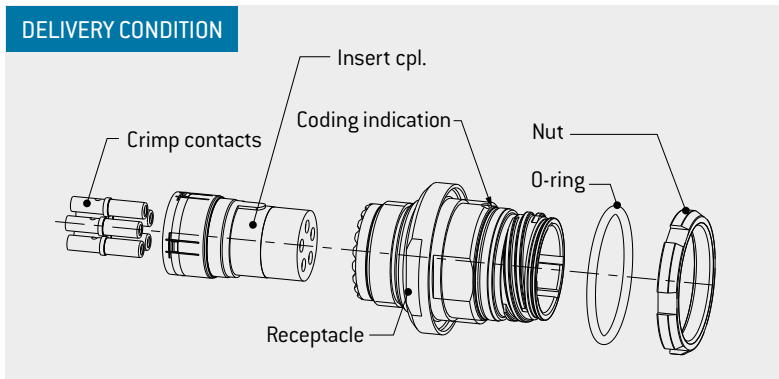

	Performance specifications – Plug in combination with		
	Push-pull plug see page 32	Break-away plug see page 34	Threaded plug see page 36
Vibration	Sine 30 g	Sine 20 g	Sine 30 g, random 37.8 g
Shock	300 g	100 g	300 g
Mating cycles	500	500	500
Operating high	+175 °C	+175 °C	+175 °C
Operating low	-65 °C	-65 °C	-65 °C
Water immersion ⁴	1 m 120 min	1 m 120 min	1 m 120 min
Humidity	25 up to 65 °C / 90 – 98 % RH / 240 h	25 up to 65 °C / 90 – 98 % RH / 240 h	25 up to 65 °C / 90 – 98 % RH / 240 h
Salt spray	96 h	96 h	96 h

Values in table refer to the connector only.

1 2 3 4 5 6 7 8 9 10 11 12 13 14 15 16 17 18 19

G B T A T O - N - 0 0 0 0

For support and customer specific solutions: sales@odu.de



ODU
ODU AMC
Advanced Military
Connectors

CONTACT INSERTS AND PCB LAYOUTS

Shell size 9

Number of contacts	Available connector styles				Contact type	Part number key				Contact size	Contact Ø mm	Single contact nominal current A	Test voltage ¹ Veff	Nominal voltage ² Vms	Termination cross section AWG								
																Termination							
08	GK	G6 / GB	K1 / KB	S1 / SB A1 / AB C1 / CB	Socket	Solder	D	0	8	W	#22 D	0.76	5	750	50	22 – 26							
						Crimp	D	0	8	S													
	GK	G6 / GB	K1 / KB	S1 / SB A1 / AB C1 / CB	Pin	Print	D	0	8	U													
						Solder	D	0	8	X													
	10	GK	G6 / GB	K1 / KB	S1 / SB A1 / AB C1 / CB	Socket	Crimp	D	0	8							P	#22 D	0.76	5	750	50	22 – 26
							Print	D	0	8							V						
GK		G6 / GB	K1 / KB	S1 / SB A1 / AB C1 / CB	Pin	Solder	0	1	0	W													
						Crimp	0	1	0	S													
GK		G6 / GB	K1 / KB	S1 / SB A1 / AB C1 / CB	Pin	Print	0	1	0	U													
						Solder	0	1	0	X													
GK	G6 / GB	K1 / KB	S1 / SB A1 / AB C1 / CB	Pin	Crimp	0	1	0	P														
GK	G6 / GB	K1 / KB	S1 / SB A1 / AB C1 / CB	Pin	Print	0	1	0	V														

Values in table refer to the connector only.

¹ Acc. to EIA-364-20F:2019-02, further information on voltage rating on page 80

² In case that other standards rule a specific use of the connector, the application specific safety criteria shall be considered first. In this context, lower voltage ratings may be valid.

³ ISO / IEC 11801:2017, further information on request

CONTACT INSERTS AND PCB LAYOUTS

Shell size 9

View on termination area		Data transmission protocols	PCB layout (view in mating direction)
Pin piece	Socket piece		
		<p>RJ45-plug Ethernet Type CAT 5 up to 1 Gbit³</p>	
		<p>—</p>	

CONTACT INSERTS AND PCB LAYOUTS

Shell size 12

Number of contacts	Available connector styles				Termination	Part number key				Contact size	Contact Ø mm	Single contact nominal current A	Test voltage ¹ Veff	Nominal voltage ² Vms	Termination cross section AWG			
																Termination		
05	GK	G6 / GB	K1 / KB	S1 / SB A1 / AB C1 / CB	Socket	Solder	0	0	5	W	#16	1.6	13	1.800	50	16 – 20		
					Socket	Crimp	0	0	5	S								
	GK	G6 / GB	K1 / KB	S1 / SB A1 / AB C1 / CB	Print	Solder	0	0	5	U								
	GK				Socket	Solder	0	0	5	X								
	G6 / GB				K1 / KB	S1 / SB A1 / AB C1 / CB	Pin	Crimp	0	0							5	P
							Pin	Print	0	0							5	V
18	GK	G6 / GB	K1 / KB	S1 / SB A1 / AB C1 / CB	Socket	Solder	M	1	8	W	14 x #22D	0.76	5	750	50	22 – 26		
					Socket	Crimp	M	1	8	S								
	GK	G6 / GB	K1 / KB	S1 / SB A1 / AB C1 / CB	Print	Solder	M	1	8	U								
	GK				Socket	Solder	M	1	8	X								
	G6 / GB				K1 / KB	S1 / SB A1 / AB C1 / CB	Pin	Crimp	M	1	8	P						
							Pin	Print	M	1	8	V						
	GK	G6 / GB	K1 / KB	S1 / SB A1 / AB C1 / CB	Socket	Solder	M	1	8	W	4 x #20MD	0.9	7.5	750	50	20 – 24		
	Socket				Crimp	M	1	8	S									

Values in table refer to the connector only.

¹ Acc. to EIA-364-20F:2019-02, further information on voltage rating on page 80

² In case that other standards rule a specific use of the connector, the application specific safety criteria shall be considered first. In this context, lower voltage ratings may be valid.

CONTACT INSERTS AND PCB LAYOUTS

Shell size 12

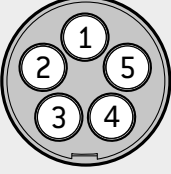
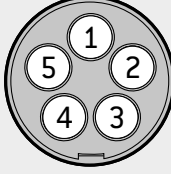
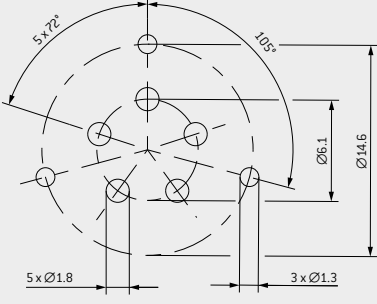
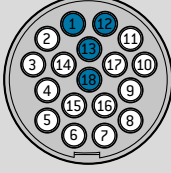
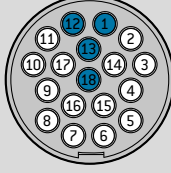
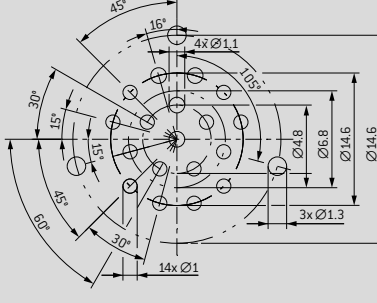
View on termination area		Data transmission protocols	PCB layout (view in mating direction)
Pin piece	Socket piece		
		-	
		-	

#22D
 #20MD

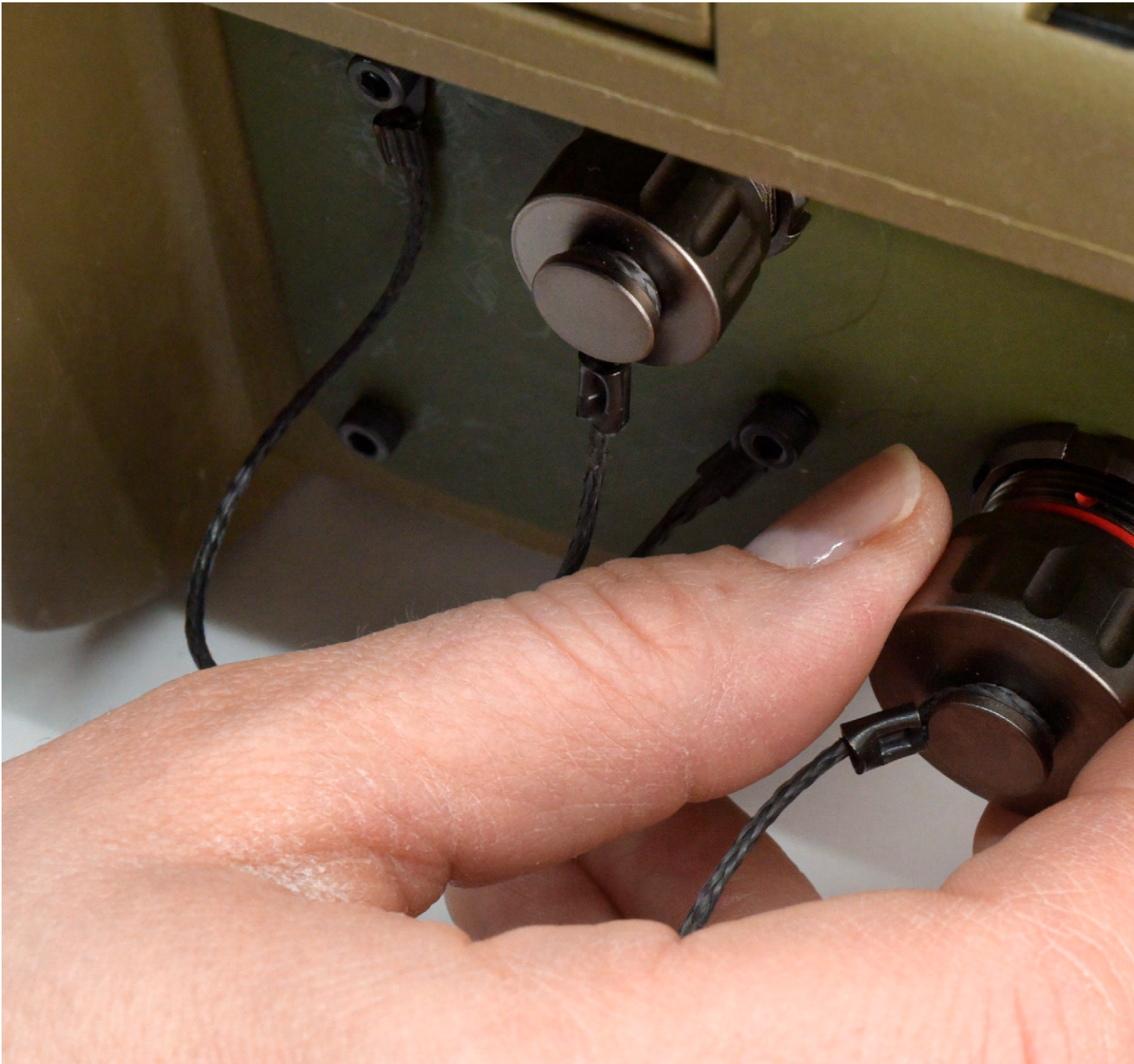

ODU AMC® SERIES T

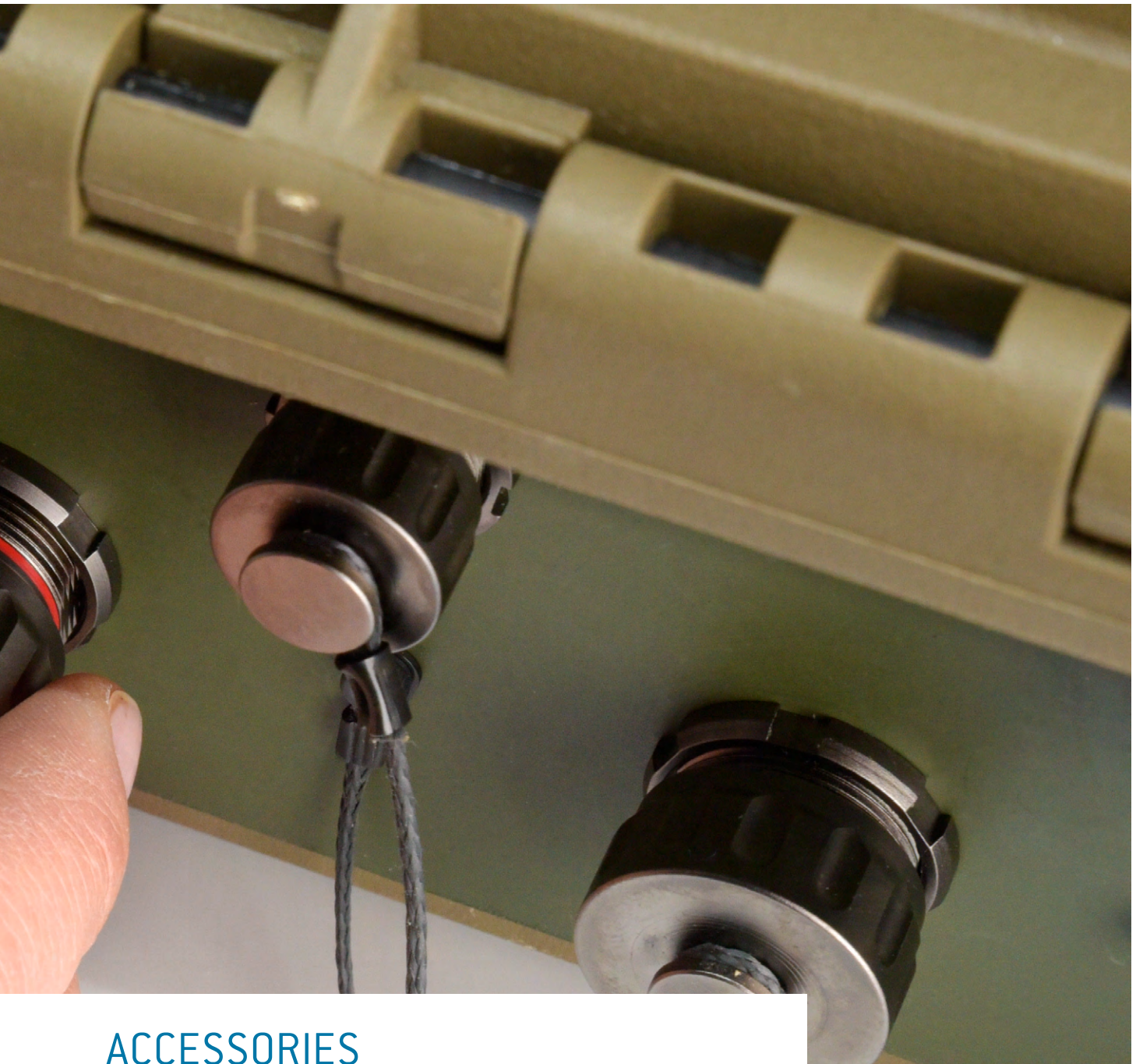

ACCESSORIES

MIL STD-contacts	56
Crimp sleeves	57
Backshells	58
Band-it	60
Heat-shrink tubes	60
Protection caps	61
Sealing plugs	63

MIL STD-CONTACTS

GENERAL INFORMATION

AS39029 crimp contacts are standard contacts for a wide variety of military circular connector applications. For platforms such as the ODU AMC® Series T, the AS39029 crimp contacts provide reliable power and signal transmission under heavy mechanical stress even in harsh environmental conditions.

The contacts are defined by the max. termination cross section:

Contact size #16 → AWG 16–20

Contact size #20 → AWG 20–24

...

ADVANTAGES

- Long proven and reliable components
- Interchangeable for repair and modification
- Field assembly possible
- Easy identification of contacts

MIL SPECIFICATION CRIMP CONTACTS

Size	AWG	Type	ODU Number	MIL-Part No.	BIN color		
#16	16–20	Socket	923.000.005.000.299	M39029/57-358	Orange	Green	Gray
		Pin	923.000.005.000.427	M39029/58-364	Orange	Blue	Yellow
#20	20–24	Socket	923.000.005.000.300	M39029/57-357	Orange	Green	Violet
		Pin	923.000.005.000.428	M39029/58-363	Orange	Blue	Orange
#22D	22–26	Socket	923.000.005.000.292	M39029/57-354	Orange	Green	Yellow
		Pin	923.000.005.000.429	M39029/58-360	Orange	Blue	Black

ODU SPECIFIC CRIMP CONTACTS

For smaller termination cross section and higher contact density without BIN color code.

Size	AWG	Type	ODU Number
#20MD	20–24	Socket	923.000.005.000.301
		Pin	185.967.000.306.000
#22MD	22–26	Socket	923.000.005.000.302
		Pin	185.A20.000.306.000
#26	26–30	Socket	923.000.005.000.303
		Pin	185.A21.000.306.000

CONTACT DESCRIPTION

BIN (Basic Identification Number):



MIL contacts have a BIN (Basic Identification Number) code consisting of three color bands around the crimp barrel. There are 10 colors, which designate a number.

0 BLACK	1 BROWN	2 RED	3 ORANGE	4 YELLOW
5 GREEN	6 BLUE	7 VIOLET	8 GRAY	9 WHITE

CRIMP SLEEVES

Accessories for cable termination are not included and have to be ordered separately.

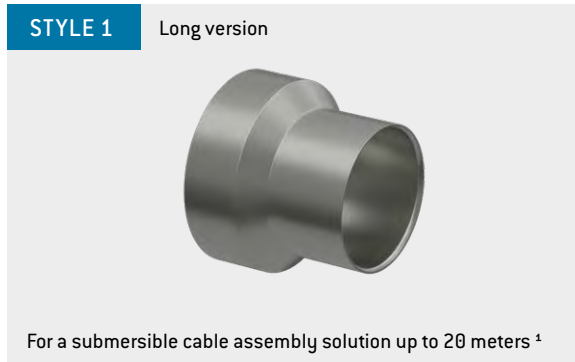

Material	CuTeP
Plating	Nickel

Crimp sleeve		
Shell size	ODU number	Style
9	7TE.440.101.304.000	1
	7TE.440.101.304.001	2
12	7TH.440.101.304.000	1
	7TH.440.101.304.001	2

Immersion Capability:

Depending on the used crimp sleeve style and used overmolding types, different immersion capabilities can be achieved.

Style	Overmolding straight	Overmolding 90°
1	20 m ¹	1 m ²
2	1 m	1 m

¹ Immersion capability depends on potting material in accordance with ODU Assembly process. See page [79](#).

² Customer specific solution possible.

BACKSHELLS

Accessories for cable termination are not included and have to be ordered separately.

SUITABLE FOR CB / SB / AB / GB / KB

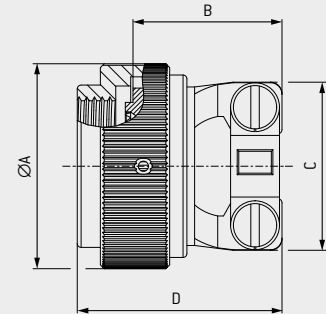
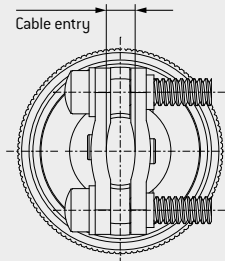

Shell size		Part number	MIL-Part No.	Ø in mm	Dimensions in mm				Cable entry	
Connector	Backshell				A	B	C	D	min.	max.
9	9	921.000.006.000.290	M85049/38S9N	19.1	23.1	21.6	27.9	2.5	5.9	
12	13	921.000.006.000.296	M85049/38S13N	25.4	25.7	27.9	30.8	4.8	8.3	

Material	Aluminium
Plating	Nickel

For further information see: [Assembly Instruction - Series T - Backshell termination \(D00016303\)](#)

SUITABLE FOR CB / SB / AB / GB / KB

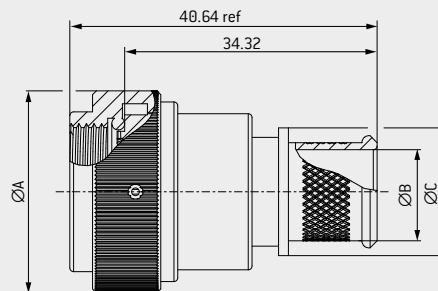

Shell size		Part number	MIL-Part No.	Ø in mm		
Connector	Backshell			A	B [+0.0 / -0.50]	C
9	9	921.000.006.000.292	M85049/88-9N03	21.82	6.60	14.22
12	13	921.000.006.000.298	M85049/88-13N03	25.04	8.13	16.00

Material	Aluminium
Plating	Nickel

For further information see: [Assembly Instruction - Series T - Backshell termination \(D00016303\)](#)

BACKSHELLS

Accessories for cable termination are not included and have to be ordered separately.

SUITABLE FOR CB / SB / AB / KB / GB

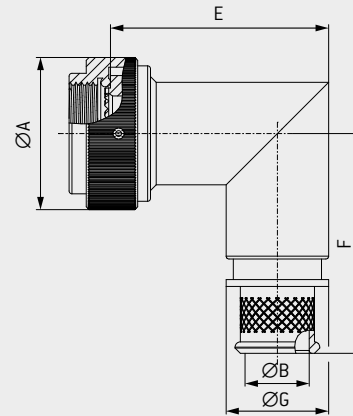

Shell size		Part number	MIL-Part No.	Ø in mm			Dimensions in mm	
Connector	Backshell			A	B [+0.0 / -0.50]	G	E	F
9	9	921.000.006.000.293	M85049/90-9N03	21.8	6.6	14.2	34.9	36
12	13	921.000.006.000.299	M85049/90-13N03	29.4	11.4	19.0	39.7	39.5

Material	Aluminium
Plating	Nickel

For further information see: [Assembly Instruction - Series T - Backshell termination \[D00016303\]](#)

SUITABLE FOR CB / SB / AB / GB / KB

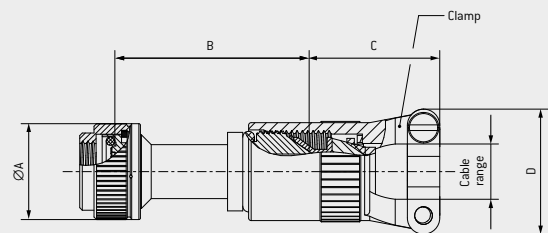
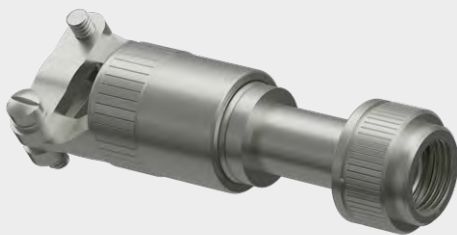

Shell size		Part number	MIL-Part No.	Cable range	Ø in mm		Dimensions in mm	
Connector	Backshell				A	B	C	D
9	9	921.000.006.000.294	M85049/189N02	3.18 mm – 6.35 mm	19.1	38.9	31.8	20.3
		921.000.006.000.402	M85049/1813N02	3.18 mm – 6.35 mm	25.4	38.9	31.8	25.4
12	13	921.000.006.000.403	M85049/1813N03	6.35 mm – 9.53 mm	25.4	38.9	31.8	25.4
		921.000.006.000.404	M85049/1813N04	9.53 mm – 12.70 mm	25.4	38.9	31.8	25.4

Material	Aluminium
Plating	Nickel

For further information see: [Assembly Instruction - Series T - Backshell termination \[D00016303\]](#)

BAND-IT

Accessories for cable termination are not included and have to be ordered separately.

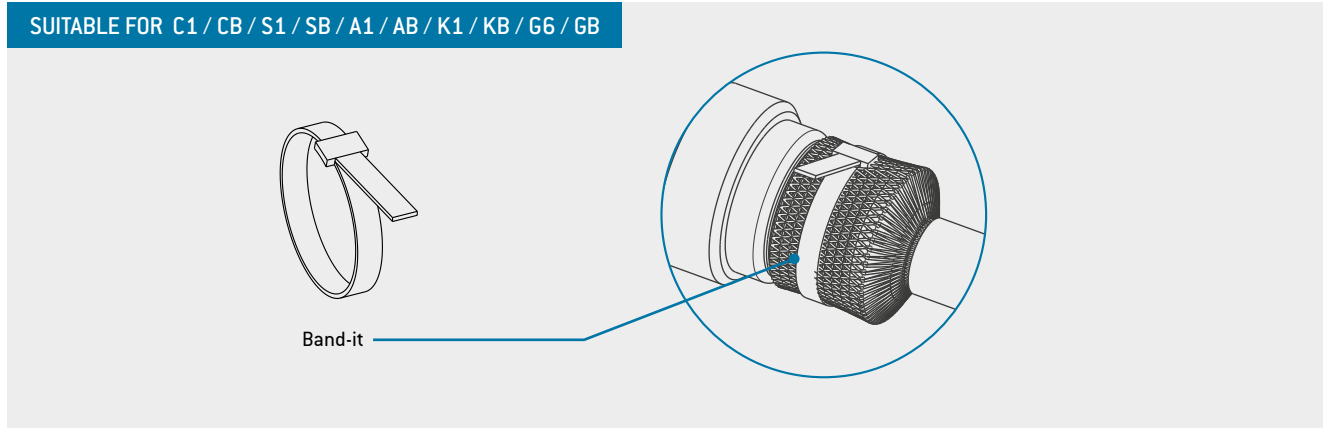

Shell size	Part number	Material
All	921.000.004.000.248	Stainless-steel

HEAT-SHRINK TUBES

Heat shrinkable tubes are used to insulate cables and wires and provide additional protection against abrasion and environmental influences, especially in the connection area of the connector.

Material	Polyester-elastomer
Temperature range	Up to 150 °C



Shell size	ODU Number	Hellermann	TE Connectivity
All	921.000.010.008.084	401-52880	202D121-3-60



Shell size	ODU Number	Hellermann
All	921.000.010.008.087	411-52480

PROTECTION CAPS

Part	Material	Surface
Cap	Aluminium	Tin-nickel over electroless nickel
Crimp ferrule	Brass	Black zinc-nickel over nickel
Lanyard	Black aramid	–
Cable lug	Copper	Black zinc-nickel

FOR RECEPTACLES GK / G6 / GB / K1 / KB

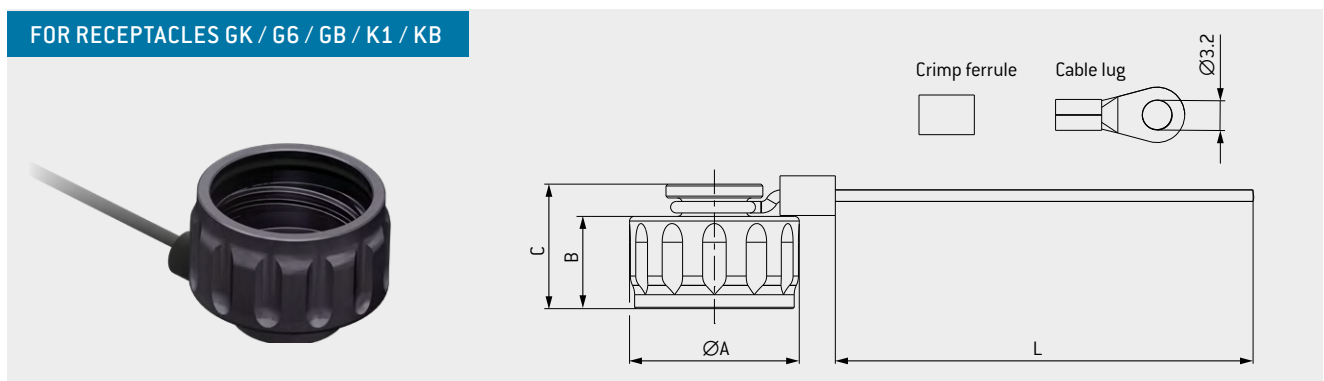

Shell size	Part number	Dimensions in mm			
		Ø A	B	C	L
9	7TE.197.001.661.000	18.4	13.5	10	200
12	7TH.197.001.661.000	23.3	15.5	12	200

FOR PLUGS S1 / SB / A1 / AB

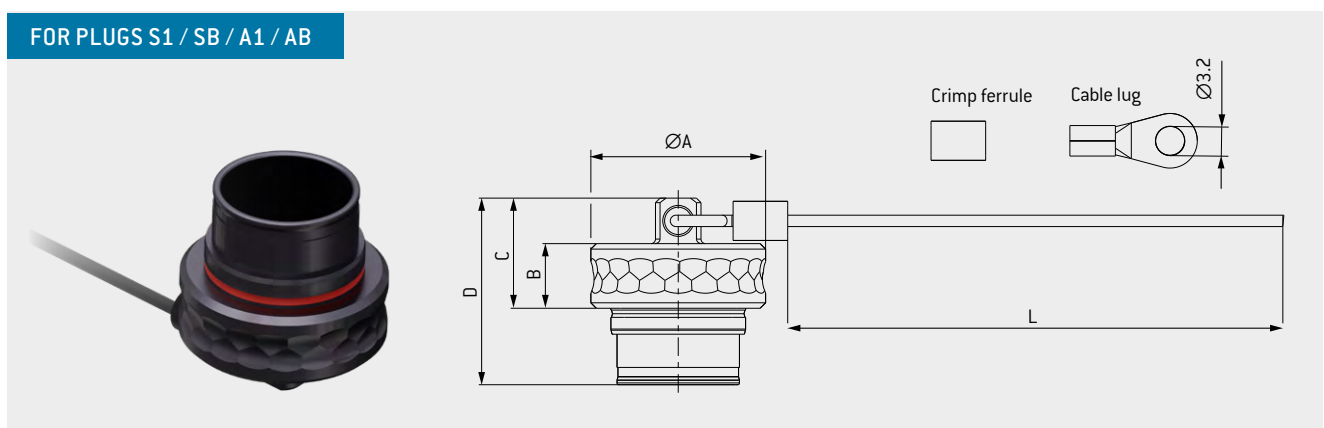

Shell size	Part number	Dimensions in mm				
		Ø A	B	C	D	L
9	7TE.297.001.661.000	19.4	14.4	19.2	20.5	200
12	7TH.297.001.661.000	22.6	17.6	24.2	25.0	200

PROTECTION CAPS

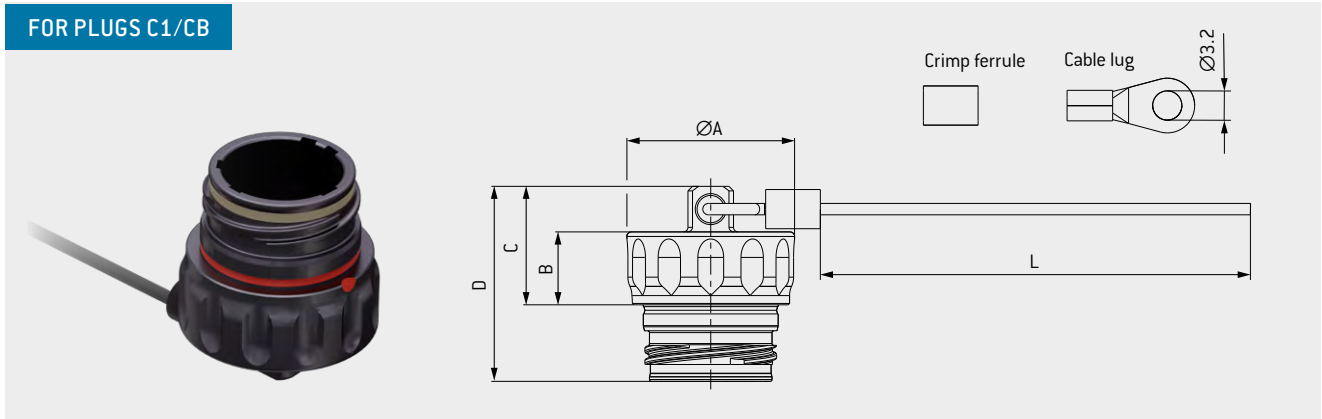

Shell size	Part number	Coding	Dimensions in mm				
			$\varnothing A$	B	C	D	L
9	7TE.597.001.661.00A	A	18.4	8.0	13.0	21.4	200
	7TE.597.001.661.00B	B					
	7TE.597.001.661.00C	C					
	7TE.597.001.661.00D	D					
12	7TH.597.001.661.00A	A	24.9	12.0	17.0	27.7	200
	7TH.597.001.661.00B	B					
	7TH.597.001.661.00C	C					
	7TH.597.001.661.00D	D					

SEALING PLUGS

The sealing plugs are used to close open or unused contact positions in series T connectors. The appropriate sealing plug can be identified by the contact size.

Material

Polyphenylsulfone (PPSU)

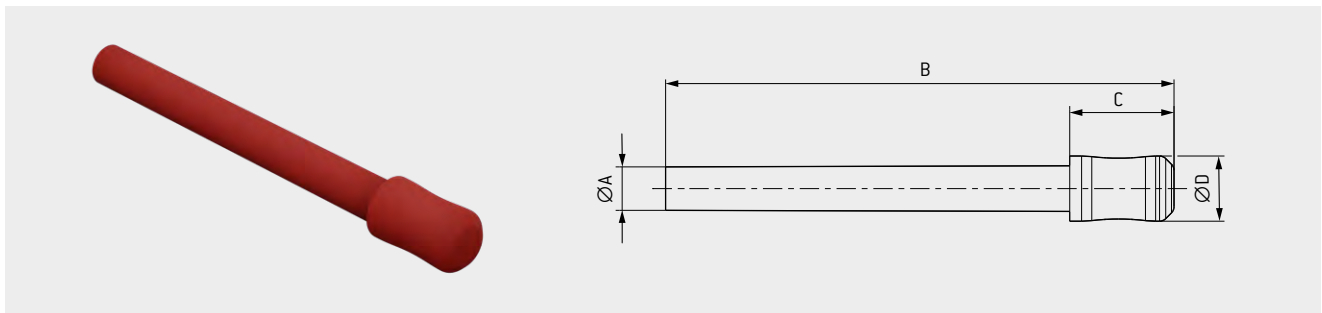

Size	Part number	MIL-Part No.	Color	Dimensions in mm			
				Ø A	B	C	Ø D
#16	021.315.951.937.000	MS27488-16-2	Green	1.8	21.7	2.3	3.2
#20	021.315.901.937.000	MS27488-20-2	Red	1.25	21.7	2.3	2.24
#20MD	021.315.949.937.000	–	Orange	1.1	21.7	2.5	1.6
#22D	021.315.942.937.000	MS27488-22-2	Black	1.0	11.7	2.4	1.5
#22MD	021.315.948.937.000	–	Green	0.82	11.7	4.1	1.3
#26	021.315.941.937.000	–	Red	0.7	11.7	4.2	1.1

Make sure that all cavities without function are equipped with unconnected contacts.
Install the sealing plug with head towards bottom of the crimp barrel.



ODU AMC® SERIES T



TOOLS

Tools for shielded termination	66
Contact crimp tools	66
Insertion and removal tools	67
Contact retention tools	67
Insert retention tools	68
Nutdriver for slotted nut	68
Complete your connector system	69
Order information for possible cable termination types	71

TOOLS FOR SHIELD TERMINATION



ODU Number	Name	Shell size
080.000.058.000.000	Band-it tool	universal
080.000.026.000.000	Housing cable crimp tool	universal
080.000.026.7TE.001	Crimp die	09
080.000.026.7TH.001	Crimp die	12

CONTACT CRIMP TOOLS

The 8-point crimping tool is used to crimp turned contacts on to a conductor. The special features of the handcrimping tool are a user-friendly display, ergonomic design and an optimum force transmission for comfortable working.



ODU Number	MIL-Part No.	Name	Contact size
080.000.073.000.000	M22520/1-01	Contact crimp tool	#16 / #20
080.000.073.101.000	M22520/1-04	Positioner	#16 / #20

For further information see: [ODU Crimp instruction 080.000.073.000.000](#)

ODU Number	MIL-Part No.	Name	Contact size
080.000.072.000.000	M22520/2-01	Contact crimp tool	#20MD #22D #22MD #26
080.000.072.106.000	-	Positioner pins / sockets	#22MD
080.000.072.104.000	-	Positioner sockets	#26
080.000.072.103.000	-	Positioner pins	#26
080.000.072.102.000	M22520/7-06	Positioner sockets	#20MD #22D
		Positioner pins	#20MD
080.000.072.101.000	M22520/7-07	Positioner pins	#22D



For further information see: [ODU Crimp instruction 080.000.072.000.000](#)

INSERTION AND REMOVAL TOOLS

ODU provides insertion & removal tools for all listed contacts. The use of the correct insertion tool ensures the correct seating of the contact in the connector. Using the correct removal tool ensures that the contact can be removed without causing damage. In addition to the plastic tools, which are mainly intended for use in a field assembly situation, ODU also offers MIL-Standard metal tweezers as a more durable option.



Size	ODU Number	MIL-Part No.	Color code insertion side	Color code removal side	Min. wire Ø	Max. wire Ø
#16	085.613.100.020.000	M81969/14-03	Blue	White	1.65	2.77
#20	085.613.100.040.000	M81969/14-10	Red	Orange	1.02	2.11
#22D	085.613.100.060.000	M81969/14-01	Green	White	0.76	1.27

Size	Type	ODU Number	MIL-Part No.	Min. wire Ø	Max. wire Ø
#16	insertion	085.613.100.070.000	M81969/8-07	1.65	2.77
	removal	085.613.100.070.001	M81969/8-08		
#20	insertion	085.613.100.050.000	M81969/8-05	1.02	2.11
	removal	085.613.100.050.001	M81969/8-06		
#22D	insertion	085.613.100.030.000	M81969/8-01	0.76	1.27
	removal	085.613.100.060.000	M81969/14-01		



Size	ODU Number	Color code insertion side	Color code removal side
#20MD	085.613.100.090.000	Purple	White
#22MD	085.613.100.100.000	Orange	White
#26	085.613.100.110.000	Black	White



CONTACT RETENTION TOOL

ODU Number	Contact size
7TH.098.004.000.000	#20 – #28
7TH.098.004.000.001	#12 – #16

ODU Retention tools are recommended for use when checking the connectors for proper seating of the contacts or the insert. Due to the simple handling, the test can be carried out in a matter of seconds. By pressing the tool against the mating face, the retention of pins and sockets and inserts is tested. Through a visualization on the tool the result can be easily identified.



Art. Nr	Type	Contact size	Color 1	Color 2	Color 3
7TH.098.004.K02.000	Pin	#16	Yellow	Red	Green
	Socket		Black	Red	Green
7TH.098.004.K07.000	Pin	#20/#20MD	Yellow	Yellow	Yellow
	Socket		Black	Yellow	Yellow
7TH.098.004.K09.000	Pin	#22D/#22MD	Yellow	Blue	Black
	Socket		Black	Blue	Black
7TH.098.004.K11.000	Pin	#26	Yellow	Green	Blue
	Socket		Black	Green	Blue

INSERT RETENTION TOOL

ODU Number (tool)	Shell size
7TH.098.003.000.000	universal

ODU Number (inserts)	Shell size
7TH.098.003.E00.000	09
7TH.098.003.H00.000	12



ODU Number	Shell size	Connector type	Contact type	Color 1	Color 2	Color 3
7TH.098.003.E00.000	09	Plug	Socket	Black	Green	Red
		Plug	Pin	Black	Green	Yellow
		Receptacle	Socket	Black	Blue	Red
		Receptacle	Pin	Black	Blue	Yellow
7TH.098.003.H00.000	12	Plug	Socket	Red	Green	Red
		Plug	Pin	Red	Green	Yellow
		Receptacle	Socket	Red	Blue	Red
		Receptacle	Pin	Red	Blue	Yellow

NUT DRIVER FOR SLOTTED NUT

ODU Number	Name	Shell size
7TE.098.001.000.000	Nut driver	09
7TH.098.001.000.000	Nut driver	12



ASSOCIATED DOCUMENTS:

- D00016300 – [Crimp contact specification](#)
- D00016301 – [Product specification](#)
- D00016302 – [Accessories](#)
- D00016303 – [Assembly instruction crimp termination](#)
- D00016304 – [Assembly instruction backshell termination](#)

COMPLETE YOUR CONNECTOR SYSTEM

Needed accessories for cable termination (e.g. crimp sleeve or band-it) must be ordered separately.

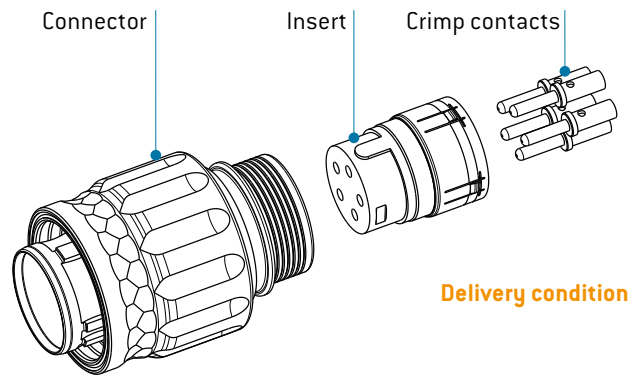

CRIMP VERSION

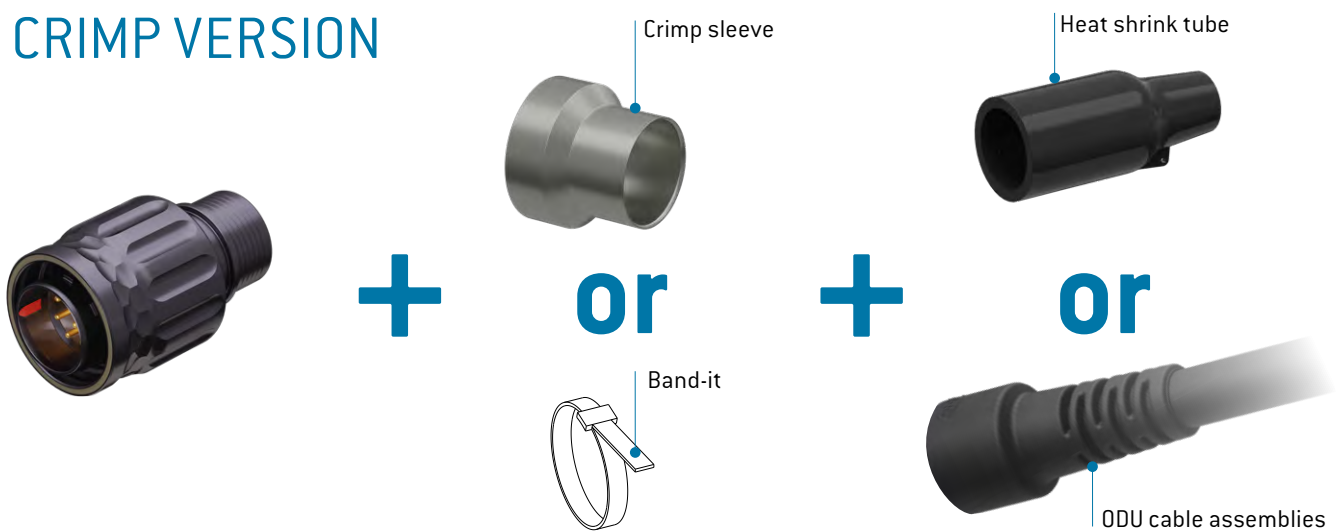

BACKSHELL VERSION

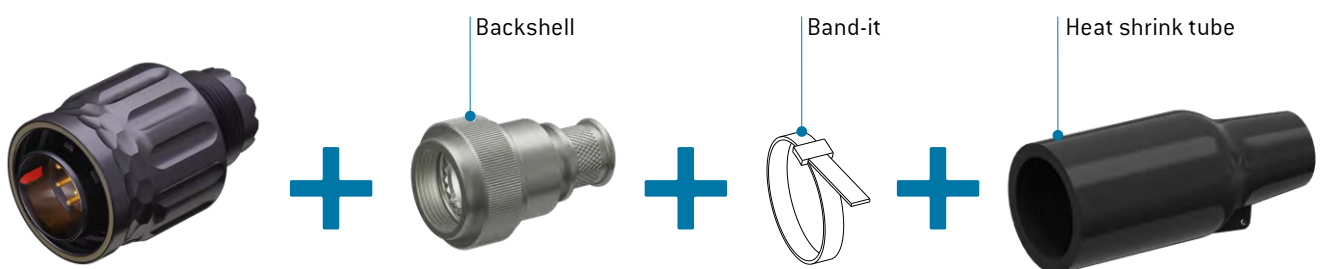

For people who like to take things into their own hands, we offer all the necessary assembly tools. See page [65](#)

The illustrated variants are only examples and may vary depending on the application or termination system being used

CUSTOMIZE THE CONNECTOR TO YOUR NEEDS:

ADDITIONAL PROTECTION



Also, do not forget that ODU also offers you factory-made overmolded cable assemblies in your preferred length!



The illustrated variants are only examples and may vary depending on the application or termination system being used

ORDER INFORMATION FOR POSSIBLE CABLE TERMINATION TYPES

Connector type	Page	Housing termination type		Overmolding possible	Additional or alternative	
		Crimp sleeve ¹	Backshell		Band-it ^{1,2}	Heatshrink ³
S1 	p. 32	✓		✓	✓	✓
A1 	p. 34	✓		✓	✓	✓
C1 	p. 36	✓		✓	✓	✓
G6 	p. 40	✓		✓	✓	✓
K1 	p. 38	✓		✓	✓	✓
SB 	p. 44		✓		✓	✓
AB 	p. 45		✓		✓	✓
CB 	p. 46		✓		✓	✓
GB 	p. 48		✓		✓	✓
KB 	p. 47		✓		✓	✓

Accessories for cable termination are not included and have to be ordered separately.

¹ Band-it can be used instead of a Crimp sleeve for cable screen termination

² A Band-It may be required for the cable shield connection depending on the used backshell.

³ Heat shrink tubes are used instead of overmolding as additional protection of crimp termination solutions.



G6TBAT0-E010SN-0000
 Material-ID: 50297129
 Mechanical coding: B
 Color coding: red

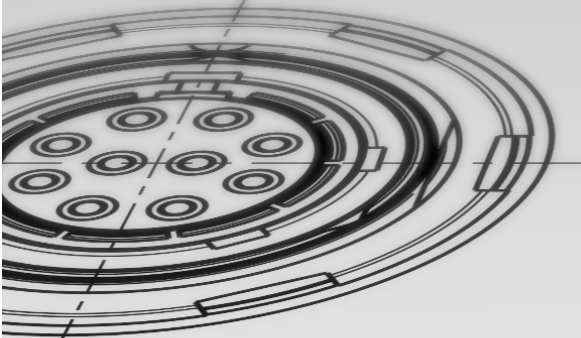

0-E010SN-0000
 50297131
 ding: C
 blue

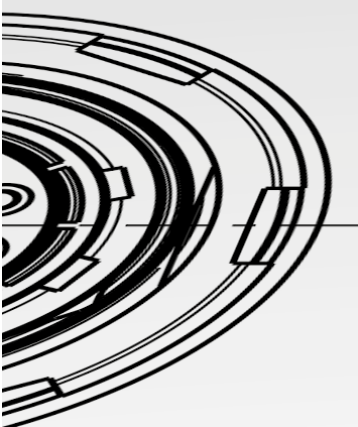

0000

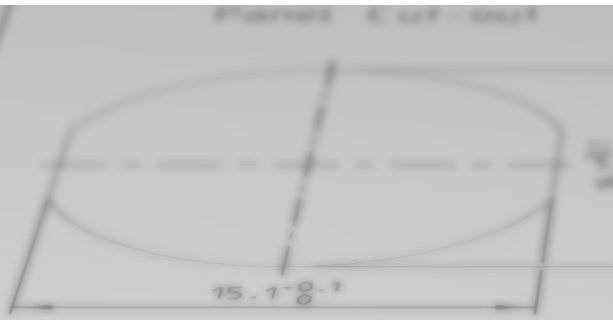

Only insert
 View in direction A
 6:1

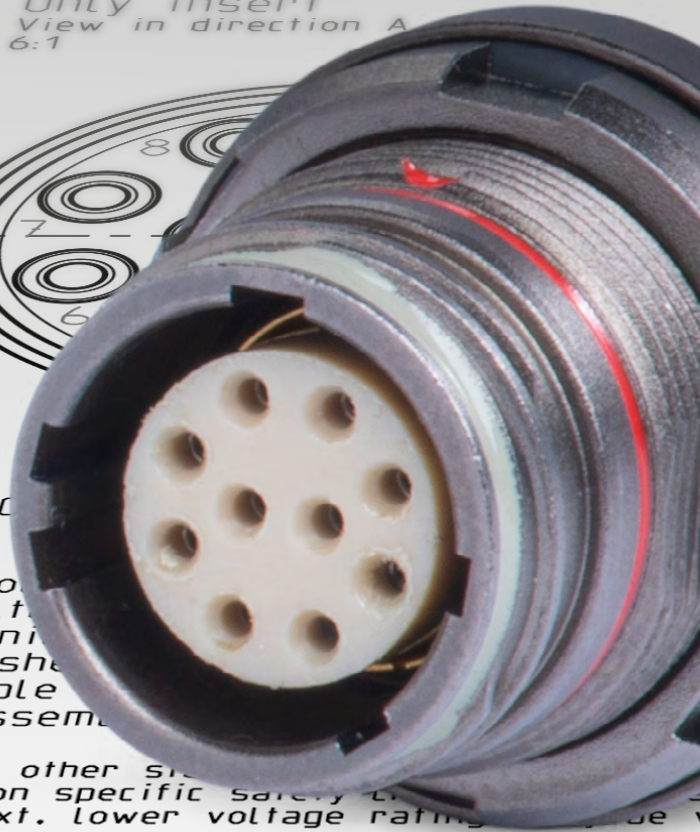

Technic

- Current
- Rated voltage
- Test voltage
- For technical
- see datasheet
- For useable
- For an assembly

- 1) In case that other specifications apply, the application specific safety data must be used. In this context, lower voltage ratings may apply.
- 2) For further contact information and crimping information see datasheet D00016300

All datasheets available at www.odu.de

Bei den hier dargestellten DDU-Steckverbindern

ODU AMC® SERIES T

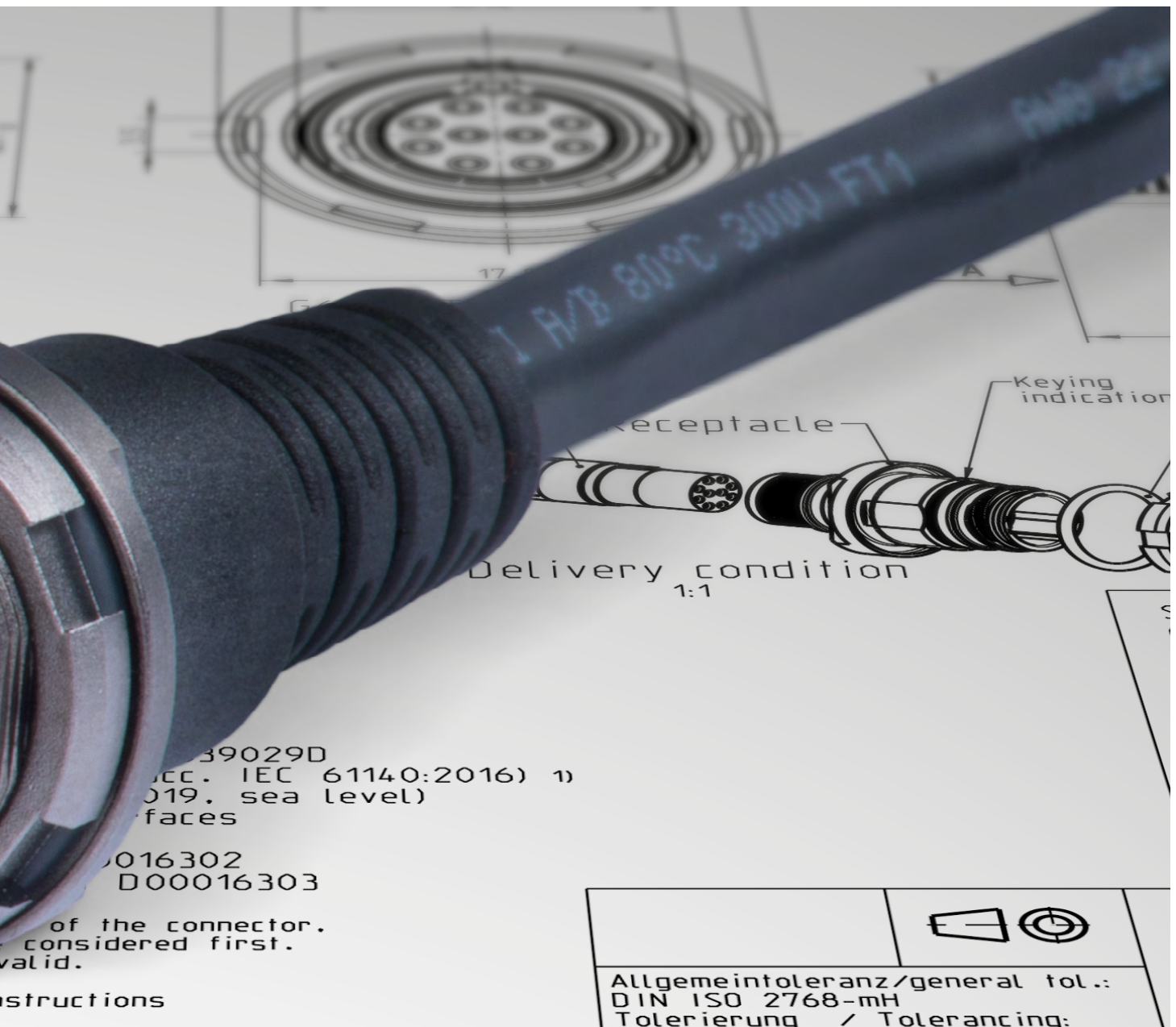

TECHNICAL INFORMATION

Technical data – ODU AMC® Series T	74
International protection classes	78
Protections of ODU AMC® Series T	79
Explanations and details of safety requirements	80
Conversions / AWG	81
International color code / IC-code	82
Current load of contacts	83
Technical terms	85

Allgemeintoleranz/general tol.: DIN ISO 2768-mH Tolerierung / Tolerancing:	

Approved

TECHNICAL DATA – ODU AMC® SERIES T

ENVIRONMENTAL AND TESTING

Description	Requirement	Procedure
Water resistance	IPX8 / 20 m 120 min ¹ IPX9K	ISO 20653:2013-02 / MIL-STD-810G: 2008 512.5 ISO 20653:2013-02
Dust or fine sand	Uncoupling and recoupling torque shall not exceed the values specified by more than 25 percent. IP6KX (settling dust)	MIL-STD-202-110 ISO 20653:2013-02
Temperature cycling	-65 °C up to +175 °C No blistering, peeling or separation of plating or other damage detrimental to the operation of the connector	EIA-364-32G, method A, test duration A, test condition V
Salt spray	96 h salt mist Unmated connectors shall show no lifting of plating or exposure of basis material.	EIA-364-26C:2014-03, test condition A
Altitude low temperature	50,000 feet simulated altitude at -65 °C The specimens shall meet the requirements of dielectric withstanding voltage and insulation resistance.	EIA-364-105B:2015-01
Ice resistance	Uncoupling and recoupling torque shall not exceed the values specified by more than 25 percent.	MIL-DTL-38999M, para. 4.5.40

¹ The protection is only assured when crimp sleeve is potted during cable assembly according to ODU AMC® Series T assembly instructions. Operating temperature for 20 m solution from -65 °C up to +85 °C. Open face 1 m / 120 min.



**OPTIMIZED
FOR HARSH
ENVIRONMENTS**



ELECTRICAL DATA

Description	Requirement			Procedure
Insulation resistance at ambient temperature	The insulation resistance between any pair of contacts and between any contact and the shell shall be greater than 5.000 MΩ			EIA-364-21E
Insulation resistance at elevated temperature	The insulation resistance between any pair of contacts and between any contact and the shell shall be greater than 1.000 MΩ at +175 °C			EIA-364-21E
Dielectric withstanding voltage at sea level	Contact Size		DWV	EIA-364-20E AC rms 50Hz
	#16		1.800 V	
	#20		1.000 V	
	#20MD		1.000 V	
	#22D		750 V	
	#22MD		750 V	
	#26		500 V	
Dielectric withstanding voltage 50.000 feet altitude	Contact Size		DWV	EEIA-364-20E AC rms 50Hz
	#16		1.000 V	
	#20		600 V	
	#20MD		600 V	
	#22D		400 V	
	#22MD		400 V	
	#26		300 V	
Contact resistance, voltage drop	Wire size	Test current	Max. voltage drop	EIA-364-06C:2006-03
	16	13 A	49 mV	
	20	7.5 A	55 mV	
	22	5 A	73 mV	
	24	3 A	45 mV	
	26	2 A	52 mV	
	28	1.5 A	54 mV	
Low level contact resistance	Wire size		Contact resistance	EIA-364-23C:2006-06
	16		5 m0hm	
	20		9 m0hm	
	22		15 m0hm	
	24		15 m0hm	
	26		15 m0hm	
	28		15 m0hm	
Current carrying capacity	Contact Size		Contact Size	IEC 60512-5-2:2002
	#16		13 A	
	#20		7.5 A	
	#20MD		7.5 A	
	#22D		5 A	
	#22MD		5 A	
	#26		2 A	
Shell-to-shell conductivity; inital ¹	Voltage drop 2.5 mV			EIA-364-83A:2017-11
Magnetic permeability	The relative permeability of the wired, assembled, and fully mated connector assembly is less than 2.0 μ.			EIA-364-54A:1999-05

Specifications only valid for connectors without cable assemblies.

¹ Specified values are tested with ODU AMC® Series T Connectors shell size 12.

TECHNICAL DATA – ODU AMC® SERIES T

MECHANICAL DATA

Description	Requirement	Procedure														
Coupling and uncoupling torque	max. engagement and disengagement (acc. MIL-DTL-38999): ShellSize09 => 0.9 Nm ShellSize12 => 1.8 Nm min. disengagement (acc. MIL-DTL-38999): ShellSize09 => 0.2 Nm ShellSize12 => 0.2 Nm	EIA-364-114:2010-10														
Mating cycles	500 cycles No mechanical or electrical defects detrimental to the operation of the connector after the specified number of cycles of mating and unmating	MIL-DTL-38999M, para. 4.5.8														
Insert retention	111N Insert shall retain in their proper location. No evidence of cracking, breaking, separation from the shell or loosening parts	EIA-364-35C:2012-04														
Electrical engagement	Mated connectors shall provide a minimum of 0.050 inch (1.27 mm) electrical engagement	MIL-DTL-38999M, para. 4.5.15														
Contact retention	<table border="1"> <thead> <tr> <th>Contact Size</th> <th>Min. Newton</th> </tr> </thead> <tbody> <tr> <td>#16</td> <td>111 N</td> </tr> <tr> <td>#20</td> <td>67 N</td> </tr> <tr> <td>#20MD</td> <td>67 N</td> </tr> <tr> <td>#22D</td> <td>44 N</td> </tr> <tr> <td>#22MD</td> <td>44 N</td> </tr> <tr> <td>#26</td> <td>20 N</td> </tr> </tbody> </table>	Contact Size	Min. Newton	#16	111 N	#20	67 N	#20MD	67 N	#22D	44 N	#22MD	44 N	#26	20 N	EIA-364-105B:2015-01
Contact Size	Min. Newton															
#16	111 N															
#20	67 N															
#20MD	67 N															
#22D	44 N															
#22MD	44 N															
#26	20 N															
Random vibration ¹	37.8 g ² s, longitudinal and perpendicular direction, 8 h each No discontinuity of greater than 1 microseconds, no cracking, breaking or loosening of parts, plug shall not become disengaged from receptacle.	EIA-364-28F:2011-02 , test condition V, Letter I														
Sine Vibration ¹	30 g, 4 h in each of three direction for a total of 12 h No discontinuity of greater than 1 microseconds, no cracking, breaking or loosening of parts, plug shall not become disengaged from receptacle.	MIL-STD-202H Method 204, test condition G amplitude: 0.06 inch frequency: 10 - 2000Hz														
Mechanical shock ¹	300g, 3 ms, half sine, 18 shocks No discontinuity of greater than 1 microseconds, no cracking, breaking or loosening of parts, plug shall not become disengaged from receptacle.	EIA-364-27C:2011-06, test condition D														

¹ Specified values are tested with ODU AMC® Series T Threaded plug.















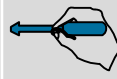

MATERIAL AND SURFACE TREATMENTS

	Requirement	Standard		Surface	Standard	Flammability
		EU	US			
Housing / Nut	AlMgSiSn1Bi	EN-AW 6023		Anthracite Tin-Nickel over nickel		
EMI-locking ring	CuBe2	CW102C (2.1248)	C17300	Gold over nickel		
Crimp sleeve	CuTeP	CW118C (2.1546)	C14500	Nickel		
Grounding ring	CuZn39Pb3	CW614N (2.0401)	C38500	Tin over Nickel		
Insulator	PEEK					UL94 (V0)
Pin contact ODU specific	CuZn38Pb2	CW608N (2.0371)	C37000	1.27 µm Gold over Nickel	MIL-G-45204D	
Pin contact MIL standard	CuZn35Pb2	CW601 (2.0331)	C34500	1.27 µm Gold over Nickel	ASTM B 488:2018, Type II, C	
Socket contact body	CuZn35Pb2	CW601 (2.0331)	C34500	Gold over Nickel	ASTM B 488:2018 , Type II	
Socket contact clip	CuBe2	CW101 (2.1247)	C17200	1.27 µm Gold over Nickel	ASTM B 488:2018, Type II, C	
Wave spring	Stainless steel	EN 10270-3 (1.4568)	S17700			
Ratchet ring	PEEK					UL94 (V0)
Grommet	FVMQ (floursilikon)					
Potting	Potting compound					UL94 (V0)
O-rings	FVMQ (floursilikon)					
Shrink boots	Polyester-elastomer					acc. to VG95343
Overmolding material	TPU					UL94 (HB)

RoHS compliant ✓

INTERNATIONAL PROTECTION CLASSES



ISO 20653:2013

Code letters (International Protection)		First code number (Degrees of protection against access to hazardous parts respectively against solid foreign objects)		Second code number (Degrees of protection against water)		
IP		6		5		
Code no.	Protection against access to hazardous parts / Protection against ingress of solid foreign objects			Code no.	Protection against harmful effects due to the ingress of water	
0	No protection		No protection against contact / No protection against solid foreign objects	0	No protection against water	No protection against water
1	Protection against contact with the back of hand (no protection against intentional contact)		Test probe with diameter 50 mm shall not penetrate completely and maintain sufficient distance from hazardous parts.	1	Protection against dripping water	 Vertical drips shall not have any harmful effects or impair performance.
2	Protection against finger contact		Jointed test finger with diameter 12.5 mm may penetrate completely, but shall maintain a sufficient distance from hazardous parts.	2	Protection against dripping water (tilted)	 Vertical drips shall not have any harmful effects or impair performance when the enclosure is tilted at any angle up to 15° on either side of the vertical
3	Protection against penetration of tools (e.g. screwdrivers)		Test probe with diameter 2.5 mm, may penetrate completely, but shall maintain a sufficient distance from hazardous parts.	3	Protection against spray water	 Water spray at an angle up to 60° on either side of the vertical shall have no harmful effects or impair performance
4	Protection against granular foreign objects		Test probe with diameter 1.0 mm, may penetrate completely, but shall maintain a sufficient distance from hazardous parts	4	Protection against splashing water	 Water which splashes against the enclosure from any direction shall not have any harmful effects or impair performance
				4K	Protection against splashing water with increased pressure	 Water which splashes against the enclosure from any direction with increased pressure shall not have any harmful effects or impair performance
5K	Protection against dust		Dust shall only penetrate in quantities which do not impair performance and safety.	5	Protection against high-velocity water	 Water which is directed against the enclosure from any direction as a jet shall not have any harmful effects or impair performance
				6	Protection against powerful water jet	 Water which is directed against the enclosure from any direction as a strong jet shall not have any harmful effects or impair performance
6K	Protection against ingress of dust		Dust shall not penetrate	6K	Protection against strong high-velocity water with increased pressure	 Water which is directed against the enclosure from any direction as a strong jet with increased pressure shall not have any harmful effects or impair performance
				7	Protection against the effects of temporary immersion in water	 Water shall not penetrate in a quantity causing harmful effects or impair performance if the enclosure is immersed in water temporarily under specified pressure and time conditions
				8	Protection against the effects of continuous immersion in water	 Water shall not penetrate in a quantity causing harmful effects if the enclosure is continuously immersed in water under conditions which shall be specified by the manufacturer
				9K	Protection against water during high-pressure/steam-jet cleaning	 Water which is directed against the enclosure from any direction shall not have any harmful effects or impair performance

PROTECTION OF ODU AMC® SERIES T

IP RATING ACC. TO. ISO 20653:2013-02 // IMMERSION ACC. TO. MIL-STD-810H:2019 512.5 // SAND AND DUST ACC. TO. MIL-STD-810H:2019 510.5

OPEN FACE	IP RATING	TYPE	MATED WITH PROTECTION CAP	IP RATING	TYPE		
	IP68 ¹	A1 / AB			IP68 ²	A1 / AB	
		S1 / SB				S1 / SB	
		K1 / KB				K1 / KB	
		G6 / GB				G6 / GB	
		GK				GK	

MATED	IP RATING	TYPE	
	IP6K8 ² (IP6K9K for overmolded version)	Plug with In-Line Receptacle	
	immersion sand and dust acc. to MIL-STD-202-110	Plug with Panel-Mount Receptacle	

¹Water resistance 1m / 120 min. Contact area is not IP protected.

²Water resistance 20 m / 120 min. The protection is only assured when crimp sleeve is potted during cable assembly according to ODU AMC® Series T assembly instructions. Operating temperature for 20 m solution from -65 °C up to +85 °C.

EXPLANATIONS AND DETAILS OF SAFETY REQUIREMENTS

OPERATING VOLTAGE (RATED VOLTAGE)

All shown connectors and cable assemblies are rated to a safety extra low voltage (SELV) of less than 50 V AC / 75 V DC, according to IEC 61140:2016 (VDE 0140-1:2016) Protection against electric shock – Common aspects for installation and equipment. In case other standards rule a specific use of the connectors and cable assemblies, the application specific safety criteria shall be considered first. In this context, lower voltage ratings may be valid.

If a higher operating voltage is needed, please refer to chapter “Voltage rating according EIA-364-20F:2019”.

VOLTAGE RATING ACCORDING

EIA-364-20F:2019-02

(TEST VOLTAGE / WITHSTANDING VOLTAGE)

WARNING:

Danger to life for operating voltages above 50 V AC / 120 V DC! The subsequently explained procedure according EIA-364-20F:2019 does not consider protection against electric shock. Suitable precautions (protective measures) such as touch protection, protective insulation, protective separation, protective earth conductor etc. must be implemented.

In case other standards rule a specific use of the connectivity solutions, the application specific safety criteria shall be considered first. This must be evaluated by the customer during the equipment engineering process.

For any advice on how the proper connectors and cable assemblies shall be chosen, please consult us and indicate the safety standard which your product has to meet.

EIA-364-20F:2019-02

„WITHSTANDING VOLTAGE – TEST PROCEDURE FOR ELECTRICAL CONNECTOR, SOCKETS AND COAXIAL CONTACTS”

The test voltage values in the catalog are determined according to EIA-364-20F:2019-02 method A, test condition I (sea level up to 2000 m) „Withstanding Voltage – Test Procedure for Electrical connectors, Sockets and Coaxial Contacts“.

The test voltage represents the physical limit of the connector and is usually set at 75% of the break-down voltage.

According to EIA-364-20F:2019-02 and former MIL-STD-1344 method 3001 it is specified to set the operating voltage (rated voltage) to 1/3 of the test voltage acc. to EIA-364-20F:2019-02.

Example:

Breakdown voltage	$1000 \text{ V AC} \times 0.75 =$
Test voltage	$750 \text{ V AC} \times 0.33 =$
operating voltage	$250 \text{ V AC}.$



CONVERSIONS / AWG (AMERICAN WIRE GAUGE)

Circular wire					
AWG	Diameter		Cross-section mm ²	Weight kg / km	Max. resistance Ω / km
	Inch	mm			
10 (1)	0.1019	2.590	5.26	46.77	3.45
10 (37/26)	0.1150	2.921	4.74	42.10	4.13
12 (1)	0.0808	2.050	3.31	29.41	5.45
12 (19/25)	0.0930	2.362	3.08	27.36	6.14
12 (37/28)	0.0910	2.311	2.97	26.45	6.36
14 (1)	0.0641	1.630	2.08	18.51	8.79
14 (19/27)	0.0730	1.854	1.94	17.23	9.94
14 (37/30)	0.0735	1.867	2.08	18.870	10.50
16 (1)	0.0508	1.290	1.31	11.625	13.94
16 (19/29)	0.0590	1.499	1.23	10.928	15.70
18 (1)	0.0403	1.020	0.823	7.316	22.18
18 (19/30)	0.0052	1.321	0.963	8.564	20.40
20 (1)	0.0320	0.813	0.519	4.613	35.10
20 (7/28)	0.0390	0.991	0.563	5.003	34.10
20 (19/32)	0.0420	1.067	0.616	5.473	32.00
22 (1)	0.0253	0.643	0.324	2.883	57.70
22 (7/30)	0.0288	0.732	0.324	2.965	54.80
22 (19/34)	0.0330	0.838	0.382	3.395	51.80
24 (1)	0.0201	0.511	0.205	1.820	91.20
24 (7/32)	0.0250	0.635	0.227	2.016	86.00
24 (19/36)	0.0270	0.686	0.241	2.145	83.30
26 (1)	0.0159	0.404	0.128	1.139	147.00
26 (7/34)	0.0200	0.508	0.141	1.251	140.00
26 (19/38)	0.0220	0.559	0.154	1.370	131.00
28 (1)	0.0126	0.320	0.0804	0.715	231.00
28 (7/36)	0.0160	0.406	0.0889	0.790	224.00
28 (19/40)	0.0170	0.432	0.0925	0.823	207.00
30 (1)	0.0100	0.254	0.0507	0.450	374.00
30 (7/38)	0.0130	0.330	0.0568	0.505	354.00
30 (19/42)	0.0123	0.312	0.0720	0.622	310.00
32 (1)	0.0080	0.203	0.0324	0.288	561.00
32 (7/40)	0.0110	0.279	0.0341	0.303	597.10
32 (19/44)	0.0100	0.254	0.0440	0.356	492.00
34 (1)	0.0063	0.160	0.0201	0.179	951.00
34 (7/42)	0.0070	0.180	0.0222	0.197	1,491.00
36 (1)	0.0050	0.127	0.0127	0.1126	1,519.00
36 (7/44)	0.0060	0.150	0.0142	0.1263	1,322.00

The American Wire Gauge (AWG) is based on the principle that the cross-section of the wire changes by 26 % from one gauge number to the next. The AWG numbers decrease as the wire diameter increases, while the AWG numbers increase as the wire diameter decreases. This only applies to solid wire.

However, stranded wire is predominately used in practice. This has the advantage of a longer service life under bending and vibration as well as greater flexibility in comparison with solid wire.

Stranded wires are made of multiple, smaller-gauge wires (higher AWG number). The stranded wire then receives the AWG numbers of a solid wire with the next closest cross-section to that of the stranded wire. In this case, the cross-section of the stranded wire refers to the sum of the copper cross-sections of the individual wires.

Accordingly, strands with the same AWG number but different numbers of wires differ in cross-section. For instance, an AWG 20 strands of 7 AWG 28 wires has a cross-section of 0.563 mm², while an AWG 20 strand of 19 AWG 32 wires has a cross-section of 0.616 mm².

Source: ASTM

INTERNATIONAL COLOR CODE / IC-CODE

For UL / CSA control cables

Core	Core color
1	Black
2	Brown
3	Red
4	Orange
5	Yellow
6	Green
7	Blue
8	Violet
9	Gray
10	White
11	White-Black
12	White-Brown
13	White-Red
14	White-Orange
15	White-Yellow
16	White-Green
17	White-Blue
18	White-Violet
19	White-Gray
20	Brown-Black
21	Brown-Red
22	Brown-Orange
23	Brown-Yellow
24	Brown-Green
25	Brown-Blue
26	Brown-Violet
27	Brown-Gray
28	Brown-White
29	Green-Black
30	Green-Brown

Core	Core color
31	Green-Red
32	Green-Orange
33	Green-Blue
34	Green-Violet
35	Green-Gray
36	Green-White
37	Yellow-Black
38	Yellow-Brown
39	Yellow-Red
40	Yellow-Orange
41	Yellow-Blue
42	Yellow-Violet
43	Yellow-Gray
44	Yellow-White
45	Gray-Black
46	Gray-Brown
47	Gray-Red
48	Gray-Orange
49	Gray-Yellow
50	Gray-Green
51	Gray-Blue
52	Gray-Violet
53	Gray-White
54	Orange-Black
55	Orange-Brown
56	Orange-Red
57	Orange-Yellow
58	Orange-Green
59	Orange-Blue
60	Orange-Violet

- The cores are counted starting in the outer layer and continuing through all layers in the same direction. The first color is the base color
- The 2nd and 3rd color is applied in the form of abrasion-resistant color rings. For 2 and 3-colored cores, the characters of the color code are lined up directly next to each other
- For cables with color repetition, the color code starts again with Black[1] from the 45th core onwards.
- For paired cores, always the two colors named in sequence are stranded.
- The color code is repeated from the 23rd and 45th pair onwards.

CURRENT LOAD OF CONTACTS

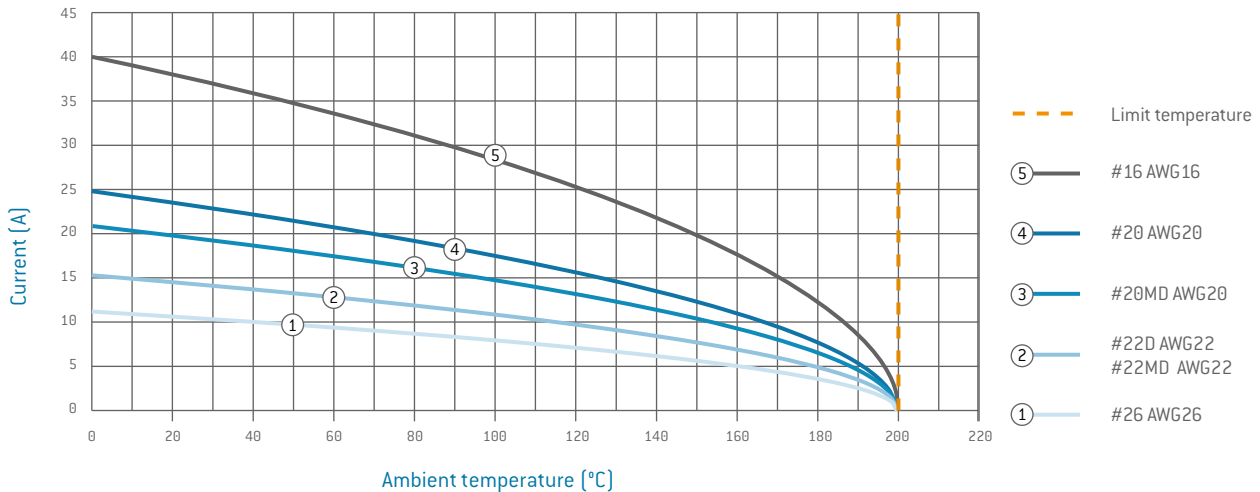

UPPER LIMIT TEMPERATURE OF SERIES T CONTACTS: +200 °C.

The wire cross-section shown in the legend was connected as test cable. In the case of multi-position connectors and cables, the heating is greater than it is with individual contacts. For that reason, it is calculated with a reduction factor. For connectors, the reduction factors for multi-core cables pursuant to DIN VDE 0298-4:2013-06 are applied. The reduction factor is factored in at 5 live wires and up.

DERATING CURVE

The corrected current-carrying capacity curve, derived from the base curve determined ($0.8 \times$ measured current). It factors in manufacturing tolerances as well as uncertainties in temperature measurement and measurement arrangement. See derating measurement method.

A current-carrying capacity curve metrologically determined according to the method described in IEC 60512-5-2:2002 (DIN EN 60512-5-2:2003-01) depending on the permissible limit temperature of the materials.

DERATING FACTOR

Number of loaded wires	Derating factor
5	0.75
7	0.65
10	0.55
14	0.5
19	0.45
24	0.4



TECHNICAL TERMS

AMBIENT TEMPERATURE

Temperature of the air or other medium in which a connector or a corresponding cable assembly is intended to be used.

AWG

American Wire Gauge (see page [81](#)).

BASE CURVE

See page [83](#).

CHEMICAL RESISTANCE

Chemical resistance is the ability of a material to protect itself against chemical attack or solvent reaction. In contrast to corrosion, there is no material removal, which is particularly typical for plastics and elastomers.

Adhesives, cleaning agents or other chemicals are often used on our products within the scope of general deployment and further handling. Contact with unsuitable chemicals may have an adverse effect on the mechanical and electrical properties of the insulation and housing materials. The connector specifications may no longer be sustainable. Please observe our handling suggestions and technical instructions as given in this catalog or corresponding assembly instructions.

CLEARANCE DISTANCE

The shortest distance by air between two conductive parts.

CODING (MECHANICAL)

Geometry detail that prevents interchangeability of otherwise identical connectors. This is useful when two or more identical connectors are attached to the same device.

CONNECTOR WITH BREAKING CAPACITY (COC)

Connector that may be mated or unmated during intended use, live or under load (according to IEC 61984:2008 (VDE 0627:2009-11)).

CONNECTOR WITHOUT BREAKING CAPACITY (COC)

Connector which is not deemed to be engaged or disengaged in normal use when live under load (according to IEC 61984:2008 (VDE 0627:2009-11)).

CONNECTORS

An element which enables electrical conductors to be connected and is intended to create and/or separate connections with a suitable counterpart (according to IEC 61984:2008 (VDE 0627:2009-11)). If not otherwise specified, these are connectors without breaking capacity (COC).

CONTACT RESISTANCE

The contact resistance is the contact resistance at the contact zone of an electrical contact pair. The contact resistance is significantly lower than the total resistance (refer to total resistance). The specifications are average values.

CORES

Electrical conductor, solid wire or multi-wire strand, with insulation as well as any conductive layers. Cables or leads may have one or more cores.

CREEPAGE DISTANCES

The shortest distance between two conductive parts along the surface of a solid insulation material. This factors in all elevations and recesses in the insulator, as long as defined minimum dimensions are on hand.

CRIMP BARREL

A terminal sleeve which can accommodate one or more conductors and be crimped by a crimping tool.

CRIMP CONNECTION (CRIMP TERMINATION)

The permanent, non-detachable and solder-free mounting of a contact to a conductor via deforming or shaping under pressure to make a good electrical and mechanical connection. Executed with crimping tool, press or automatic crimping machine (see page [66](#)).

CRIMPING AREA

The specified area of the crimp barrel in which the crimp termination is executed by means of deforming or shaping the barrel under pressure around the conductor.

DELIVERY FORM

Connectors can be delivered in assembled form or as individual parts.

TECHNICAL TERMS

DERATING CURVE

See page [83](#).

DERATING MEASUREMENT METHOD IN ACCORDANCE WITH IEC 60512-5-2:2002 (DIN EN 60512-5-2:2003-01)

According to VDE 0298-4:2013-06, with connectors and cables over 5 contacts, the heating is greater than it is with individual contacts. For that reason, the aforementioned standard is calculated with a derating factor.

INSERTION AND WITHDRAWAL FORCE

The force required to fully insert or withdraw pluggable elements without the influence of a coupling or locking device.

INSULATOR

Part of a connector that separates conductive parts with different potential, usually identical to the contact carrier.

MATING CYCLES

A mating cycle consists of one insertion and withdrawal action of both connector parts with each other. The given values are only valid under the following conditions: clean environment, adequate radial alignment, flawless counter contact pins.

NOMINAL VOLTAGE

The nominal voltage of the power source for which the connector is being used. The nominal voltage may not be higher than the rated voltage of the connector.

OPERATING TEMPERATURE

Permissible temperature range between the uppermost and lowermost limits. This includes contact heating through current-carrying capacity.

OPERATING VOLTAGE

The operating voltage is the voltage supply at the device. The operating voltage may not be higher than the rated voltage of the connector.

PCB TERMINATION

A conductive connection between the PCB and an element in through-hole assembly, THT (through-hole technology).

PRINTED CIRCUIT BOARD (PCB)

A PCB is a carrier for electronic components. It serves the purposes of mechanical mounting and electrical connection.

RATED CURRENT (NOMINAL CURRENT)

See from page [50](#).

RATED VOLTAGE

The rated voltage which the manufacturer specifies for a connector and which the operating and performance features relate to.

REDUCTION FACTOR

Based on VDE 0298-4:2013-06, connectors and cables with more than 5 contacts have a higher heating rate compared to individual contacts. For this reason, the aforementioned standard is calculated with a reduction.

SOLDER CONNECTION (SOLDER TERMINATION)

Termination technology in which a molten additional metal (solder) with a lower melting point than the base materials to be connected is used to attach two metallic materials to one another.

STRANDED WIRE

The stranded wire is an electrical conductor consisting of thin individual wires and is therefore easy to bend.

TERMINATION CROSS-SECTION

The specified cross-sections correspond to a "fine-wire" conductor structure (7/19 wire) according to AWG (ASTM B258-14) or to a "fine-wire" conductor structure pursuant to IEC 60228:2004 (VDE 0295:2005-09; Class 5), borderline conductor structures require a separate review.

TERMINATION TECHNOLOGIES

Methods for connecting the leads to the electro-mechanical element, such as solder-free connections pursuant to IEC 60352 (DIN EN 60352): crimp, screw connection etc. or soldering connection.

TEST VOLTAGE

The test voltage which a connector or a corresponding cable assembly can withstand under defined conditions without dielectric breakdown or flashover.

TECHNICAL TERMS

TIGHTNESS ISO 20653:2013-02 / MIL-STD-810G: 2008 512.5
ISO 20653:2013-02

See protection types on page [74](#).

TOTAL RESISTANCE

Total resistance value measured from terminal to terminal (e.g. without crimp resistance). The specifications are average values.

WIRE

Solid conductor

GENERAL NOTE

The connectors and cable assemblies listed in this catalog are generally designed as connectors without breaking capacity unless otherwise stated. The rated voltage specification given on the respective data sheet must be respected. Suitable precautionary measures must be taken to ensure that people do not come into contact with live conductors during installation and operation. All entries in this catalog were thoroughly reviewed before printing. ODU reserves the right to make changes based on the current status of knowledge without prior notice and without being obliged to provide replacement deliveries or refinements of older designs.

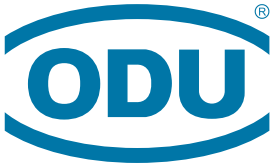

ODU GROUP WORLDWIDE

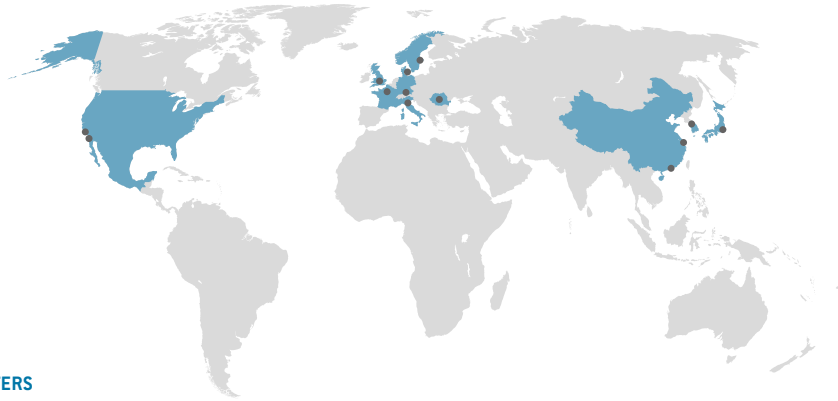

HEADQUARTERS

ODU GmbH & Co. KG

Pregelstraße 11, 84453 Mühldorf a. Inn, Germany

Phone: +49 8631 6156-0, Fax: +49 8631 6156-49, E-mail: sales@odu.de

SALES LOCATIONS

ODU (Shanghai)

International Trading Co., Ltd.

Phone: +86 21 58347828-0

E-mail: sales@odu.com.cn

www.odu.com.cn

ODU (HK) Trading Co., Ltd.

Phone: +852 3963-9588

E-mail: sales@odu.hk

www.odu-connectors.com

ODU Denmark ApS

Phone: +45 2233 5335

E-mail: sales@odu-denmark.dk

www.odu-connectors.com/da

ODU-France SARL

Phone: +33 1 3935-4690

E-mail: sales@odu.fr

www.odu-connectors.com/fr

ODU Italia S.R.L.

Phone: +39 331 2223929

E-mail: sales@odu-italia.it

www.odu-connectors.com/it

ODU Japan K.K.

Phone: +81 3 6441 3210

E-mail: sales@odu.co.jp

www.odu-connectors.com/ja

ODU Korea Inc.

Phone: +82 2 6964 7181

E-mail: sales@odu-korea.kr

www.odu-connectors.com/ko

ODU Romania Manufacturing SRL

Phone: +40 269 704638

E-mail: sales@odu-romania.ro

www.odu-connectors.com/ro

ODU Scandinavia AB

Phone: +46 176 18266

E-mail: sales@odu.se

www.odu-connectors.com/sv

ODU-UK Ltd.

Phone: +44 330 002 0640

E-mail: sales@odu-uk.co.uk

www.odu-connectors.com/uk

ODU-USA Inc.

Phone: +1 805 484-0540

E-mail: sales@odu-usa.com

www.odu-connectors.com/us

Further information and specialized representatives can be found at:

www.odu-connectors.com/contact

PRODUCTION AND LOGISTICS SITES

Germany Otto Dunkel GmbH

China ODU (Shanghai) Connectors Manufacturing Co., Ltd.

Mexico ODU Mexico Manufacturing S. de R.L. de C.V.

Romania ODU Romania Manufacturing SRL

USA ODU North American Logistics Inc.



Simply scan the QR code to download the entire publication.

All dimensions are in mm. Some figures are for illustrative purposes only. Subject to change without notice. Errors and omissions excepted. We reserve the right to change our products and their technical specifications at any time in the interest of technical improvement. This publication supersedes all prior publications.