

| PART NO    | ENGINEERING NO. | FINISHED LENGTH |
|------------|-----------------|-----------------|
| 1200680175 | 884A30A09M003   | 0.3M [1 FT]     |
| 1200680176 | 884A30A09M006   | 0.6M [2 FT]     |
| 1200680177 | 884A30A09M010   | 1M [3 FT 3 IN]  |

(A) PART NO. MATRIX  
**884A30A09M003**

FINISHED LENGTH:  
M005= 0.5 METER  
M010= 1 METER  
M100= 10 METER

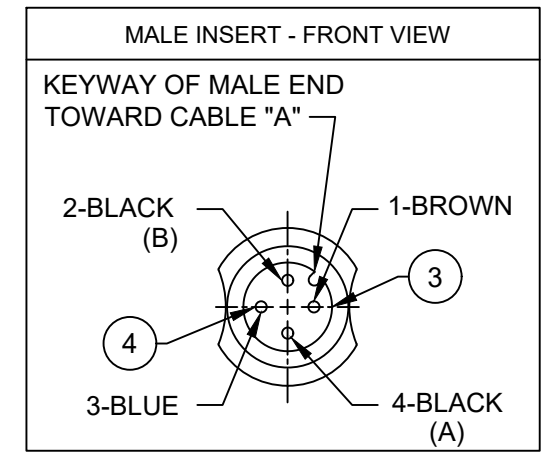

- NOTES:
- MATERIAL: AS NOTED
  - FINISH: AS NOTED
  - ELECTRICAL:  
VOLTAGE: 250V (A)  
CURRENT: 4A
  - TEMP RATING: -20°TO +105°C (A)
  - PROTECTION: IP67 (WHEN MATED)
  - COUPLING THREAD:  
FEMALE: M12 X 1 INTERNAL THD.  
MALE: M12 X 1 EXTERNAL THD.
  - UL RECOGNIZED FILE: E152210 (A)  
CSA CERTIFIED FILE: LR6837
  - ALL DIMENSIONS ARE FOR REFERENCE UNLESS TOLERANCED OR NOTED OTHERWISE

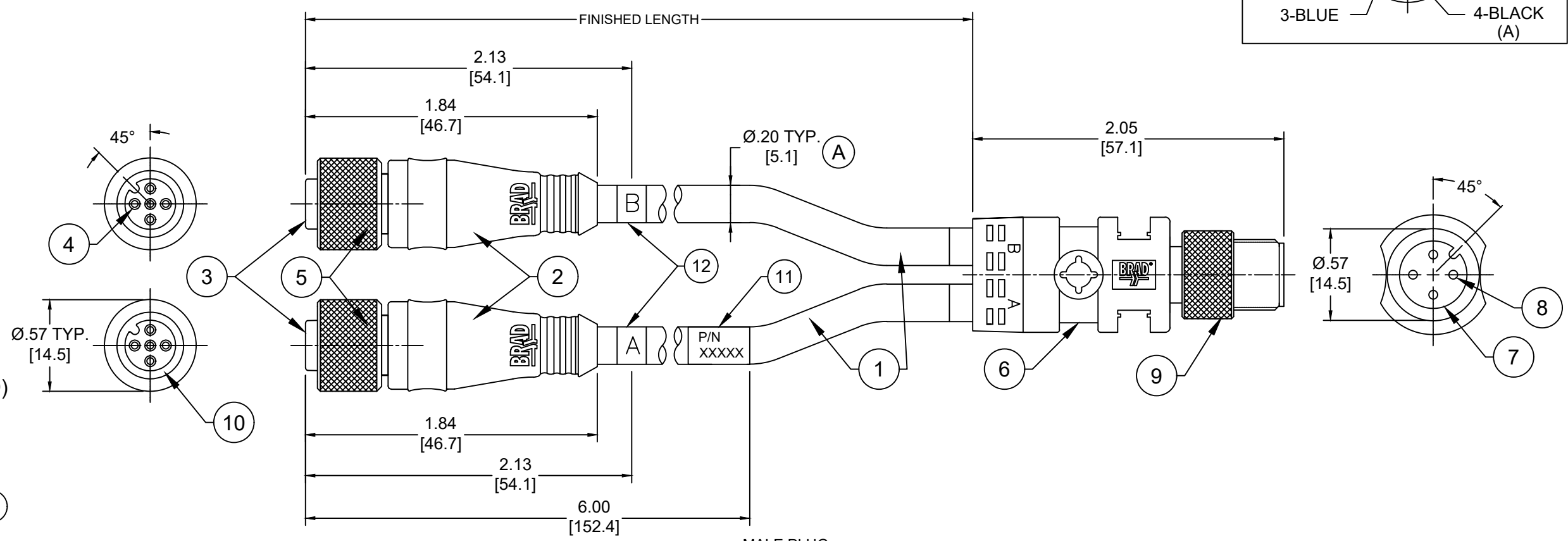

| ITEM | DESCRIPTION         | MATERIAL     | FINISH           |
|------|---------------------|--------------|------------------|
| 12   | ID LABEL            | VINYL        | BLACK/WHITE (A)  |
| 11   | WRAP LABEL          | VINYL        | BLACK/YELLOW (A) |
| 10   | O-RING              | VITON        | RED              |
| 9    | MALE COUPLING NUT   | BRASS        | NICKEL PLATED    |
| 8    | CONTACT PIN         | COPPER ALLOY | GOLD OVER NICKEL |
| 7    | MALE INSERT         | PUR          | BLACK            |
| 6    | MALE OVERMOLD       | PUR          | YELLOW (A)       |
| 5    | FEMALE COUPLING NUT | BRASS        | NICKEL PLATED    |
| 4    | CONTACT SOCKET      | COPPER ALLOY | GOLD OVER NICKEL |
| 3    | FEMALE INSERT       | PUR          | BLACK            |
| 2    | FEMALE OVERMOLD     | PUR          | YELLOW (A)       |
| 1    | CABLE #22-3         | PVC          | YELLOW           |

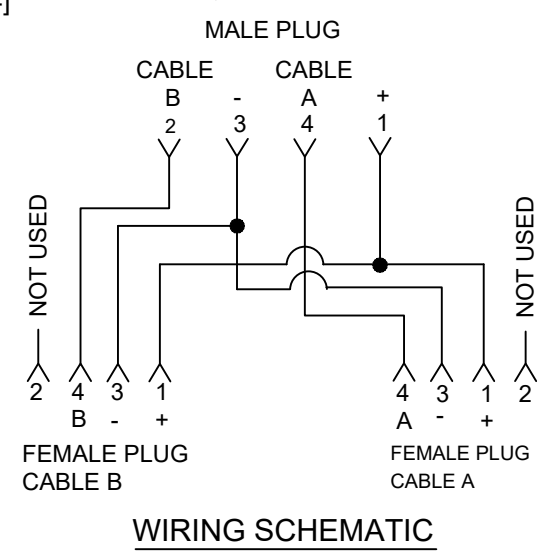

(A) CABLE LENGTH TOLERANCES

|                         |                         |
|-------------------------|-------------------------|
| <.3M [1FT]              | +19mm-0 [+ .75in-0]     |
| .3 - .9M [1 - 3FT]      | +44.5mm-0 [+1.75in-0]   |
| .9 - 1.8M [3 - 6FT]     | +55.6mm-0 [+2.19in-0]   |
| 1.8 - 3.7M [6 - 12FT]   | +88.9mm-0 [+3.50in-0]   |
| 3.7 - 7.3M [12 - 24FT]  | +165.1mm-0 [+6.50in-0]  |
| 7.3-14.6M [24 - 48FT]   | +317.5mm-0 [+12.50in-0] |
| 14.6 - 30.5M [48-100FT] | +622.3mm-0 [+24.50in-0] |
| OVER 30M [100FT]        | +2% OF FINISHED LENGTH  |

|  |   |                         |  |                           |                            |
|--|---|-------------------------|--|---------------------------|----------------------------|
| FUNCTIONAL SYMBOLS<br>FA=0<br>FE=0<br>FP=0 | THIS DRAWING CONTAINS INFORMATION THAT IS PROPRIETARY TO MOLEX ELECTRONIC TECHNOLOGIES, LLC AND SHOULD NOT BE USED WITHOUT WRITTEN PERMISSION | SCALE<br>INCH/MM<br>NTS | CURRENT REV DESC: ITEM 2 & 6 WAS TPU & 11 WAS MYLAR. ADDED ITEM-12, UL, CSA, CABLE DIA, TOL CHART & PN MATRIX. UPDATED TEMP RATING AND VOLTAGE WAS 30VDC |                           |                            |
|  | GENERAL TOLERANCES (UNLESS SPECIFIED)   | EC NO: 669893           | DRWN: ABENJAMINLW 2021/03/23   |                           |                            |
| DIVISIONAL SYMBOLS                         | 4 PLACES ±--- ±---  | mm INCH                 | 3 PLACES ±--- ±---   | 2021/07/12                | PRODUCT CUSTOMER DRAWING   |
|  | 3 PLACES ±--- ±---  |                         | 2 PLACES ±--- ±---   | 2021/07/14                |                            |
|  | 1 PLACE ±--- ±---   |                         | 0 PLACES ±--- ±---   | INITIAL REVISION:         | DOCUMENT NUMBER            |
|  | ANGULAR TOL ± --- °   |                         | DRAFT WHERE APPLICABLE MUST REMAIN WITHIN DIMENSIONS   | DRWN: BBRAUCH 2010/02/08  | SD-120068-024              |
|  |   |                         | THIRD ANGLE PROJECTION   | APPR: NSTAUDIG 2010/02/15 | DOC TYPE DOC PART REVISION |
|  |   |                         | DRAWING A3-SIZE  | SERIES 120068             | PSD 001 A                  |
|  |   |                         | MATERIAL NUMBER  | CUSTOMER                  | SHEET NUMBER               |
|  |   |                         | SEE CHART  | GENERAL MARKET            | 1 OF 1                     |