

Revision Level			Revision Record	Changed	Date	Approved	Date
Drawing	State	Part					
03.1	Design Release	-	SEE ECN# 014537	TAT	7/23/18	EJH	7/23/18

REFERENCE:

PERFORMANCE REQUIREMENTS AT DRY AS MOLDED:

1. FIR TREE PUSH IN FORCE: 45 NEWTONS (10 LBS) MAX IN THE APPLICABLE NOMINAL HOLE SIZE AND A PLATE THICKNESS OF 1.8mm.
2. FIR TREE PULL OUT FORCE: 110 NEWTONS (25 LBS) MIN IN THE APPLICABLE NOMINAL HOLE SIZE AND A PLATE THICKNESS OF 1.8mm.
3. SHEET METAL THICKNESS RANGE: 0.60mm - 5.5mm
4. APPLICABLE HOLE SIZE:
A. 6.5mm +0.5/-0.4
5. FITS USCAR MATING HOLE EWCAP-007 (NOT A TEST SPEC)

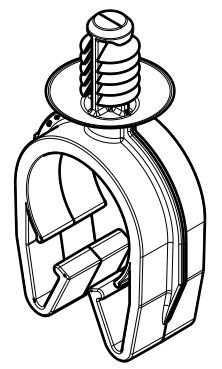
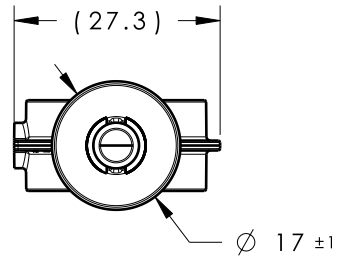

ISOMETRIC VIEW

NOTES:



1. MAXIMUM PERCENT REGRIND PERMISSIBLE: 25%
2. MAX ALLOWABLE MISMATCH TO BE 0.25mm.
3. MAX ALLOWABLE FLASH TO BE 0.1mm.

*PATENT PENDING 29/582,271



CAVITY ID NUMBER, 'TCA' AND PART DIAMETER TO BE LOCATED ON THIS SURFACE

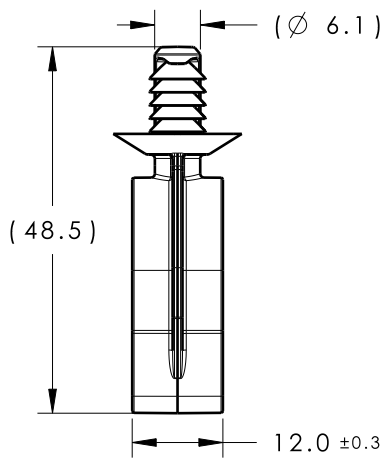
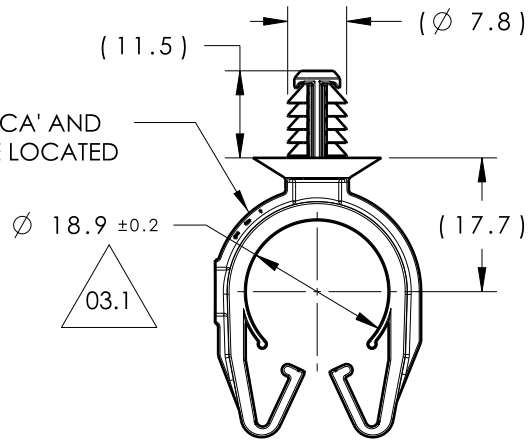

GLOBAL PART DESCRIPTION		
MOC19FT6.5-PA66HIRHSUV-BK		

DIAMETER RANGE		
HARNESS	HOSE	HARD PIPE/TUBE
17.0MM-20.0MM	17.0MM-20.0MM	19.0MM-21.8MM



*RECOMMENDED SIZES MAY DIFFER DEPENDING ON THE APPLICATION, PRODUCT REQUIREMENTS AND MATERIALS USED

Material PA66HIRHSUV COLOR: BLACK 	Units millimeters Tolerance defined on each dimension	The copyright of this drawing is reserved by HellermannTyton. It is issued on condition that it is not reproduced, copied or disclosed to a third party, either wholly or in part, without the consent of HellermannTyton.	Drawn	CRB	08/09/16	Article/Type-No	MOC19FT6.5	Scale	1:1
			Approved	EJH	09/30/16	Title	19MM (3/4") MOC WITH 6.5MM FIR TREE	Project Number	16-0322
			 North America Email: corp@htamericas.com Web: www.hellermann.tyton.com			Drawing-No	16-0322-009-CSU	PRODUCTION : Phase	Format
Sheet	1/1								