

# TMC6300 Datasheet

**Highly Efficient Low Voltage, Zero Standby Current Driver for 3-Phase BLDC/PMSM Motors up to 2A peak, Triple Half-Bridge with separate HS and LS control signals.**

+

+

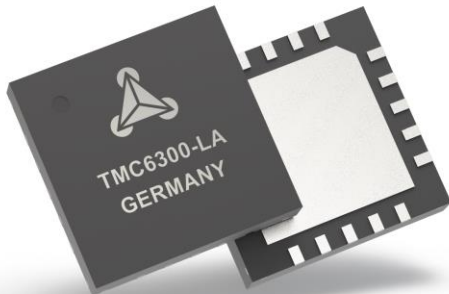

+

+

## APPLICATIONS

- IOT & Handheld devices
- Battery operated motors
- Printers, POS
- Toys
- Office and home automation
- CCTV, Security
- HVAC
- Mobile medical devices

## FEATURES AND BENEFITS

**Voltage Range** 2V (1.8V) ... 11V DC:

**Battery Operation** min. 2 AA / NiMh cells, or 1-2 Li-Ion cells

**3-Phase** motors up to 2A (peak)

**Direct Bridge** control for BLDC or PMSM sine-commutation

**Standby** <50nA typ. current draw

**Low RDSon** LS 170mΩ & HS 170mΩ (typ.)

**Full Protection & Diagnostic** output

**Tiny** of QFN 3\*3 with 20 pins

## DESCRIPTION

Working from a single Li-Ion cell or dual AA batteries the TMC6300 is optimally suited for battery operated equipment. Operate a BLDC motor with block or sine-commutation using 6-line control from a CPU. Integrated power-MOSFETs handle motor current up to 2A. Protection and diagnostic features support robust and reliable operation. Its integrated charge-pump for best-in-class RDSon and ultra-low standby current ensure best efficiency even at low supply voltage and longest battery life.

## BLOCK DIAGRAM

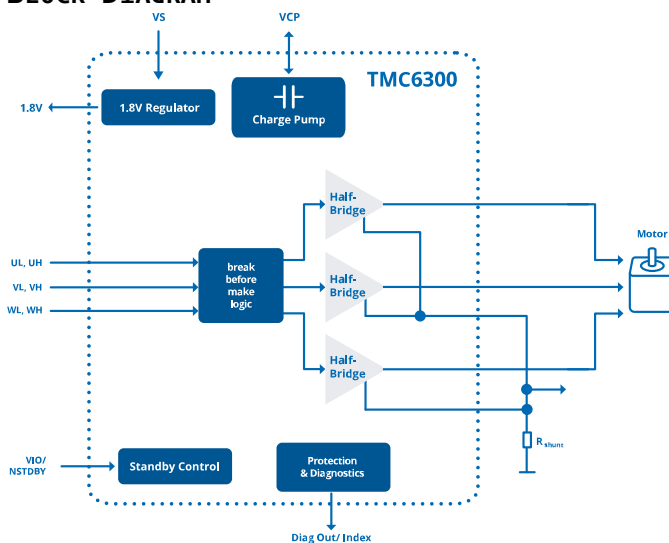

## APPLICATION EXAMPLES: SIMPLE SOLUTIONS – HIGHLY EFFECTIVE

The TMC6300 scores with power density, integrated power MOSFETs and high efficiency. It covers a wide spectrum of applications from battery systems to embedded applications with up to 2A motor current per coil. Extensive support enables rapid design cycles and fast time-to-market with competitive products.

### BLDC MOTOR DRIVER

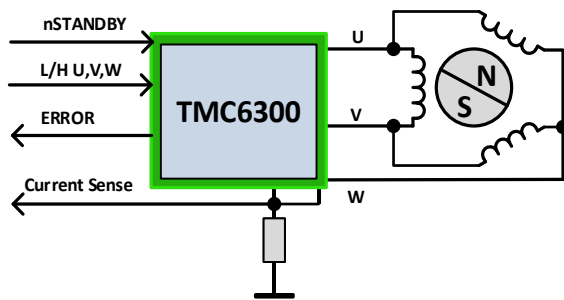

A CPU operates the driver via individual high-side and low-side control signals. Current feedback is possible via a single foot-point shunt.

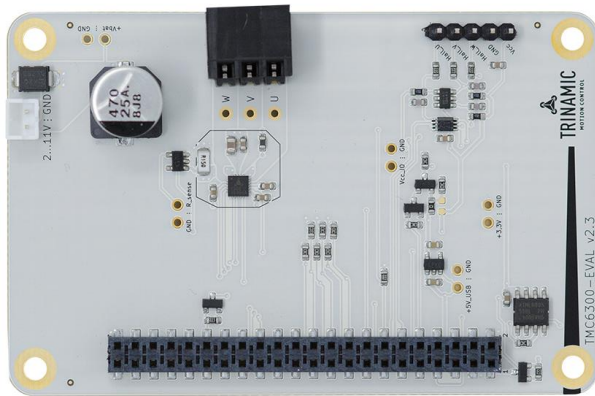

The TMC6300-EVAL is part of TRINAMIC's universal evaluation board system, which provides a convenient handling of the hardware as well as a user-friendly software tool for evaluation. The TMC6300 evaluation board system consists of three parts: Landungsbrücke (base board), Eselsbrücke (connector board with test points), and TMC6300-EVAL.

### ORDER CODES

Order code	PN	Description	Size [mm <sup>2</sup> ]
TMC6300-LA	00-0190	Low voltage BLDC motor driver	3 x 3
TMC6300-LA-T	00-0190-T	-T denotes tape on reel packing of devices	
TMC6300-BOB	40-0185	Break out board with TMC6300	20 x 25
TMC6300-EVAL	40-0184	Evaluation board for TMC6300	85 x 55
ESELSBRÜCKE	40-0098	Connector board fitting to Landungsbrücke	61 x 38
LANDUNGSBRÜCKE	40-0167	Baseboard for TMC6300-EVAL and further evaluation boards	85 x 55
TMC6300-EVAL-KIT	41-0037	TMC6300-EVAL with Landungsbrücke & Eselsbrücke	

# Table of Contents

<b>1</b>	<b>PRINCIPLES OF OPERATION</b>	<b>4</b>	7.1	OPERATIONAL RANGE	12
<b>2</b>	<b>PIN ASSIGNMENT</b>	<b>5</b>	7.2	DC AND TIMING CHARACTERISTICS	13
2.1	PACKAGE OUTLINE	5	7.3	THERMAL CHARACTERISTICS	15
2.2	SIGNAL DESCRIPTIONS	5	<b>8</b>	<b>LAYOUT CONSIDERATIONS</b>	<b>16</b>
<b>3</b>	<b>SAMPLE CIRCUITS</b>	<b>6</b>	8.1	EXPOSED DIE PAD	16
3.1	STANDARD APPLICATION CIRCUIT	6	8.2	WIRING GND	16
3.2	HIGHLY EFFICIENT DRIVER	7	8.3	SUPPLY FILTERING	16
3.3	LOW POWER STANDBY	8	8.4	LAYOUT EXAMPLE	17
3.4	VERY LOW I/O VOLTAGE OPERATION	8	<b>9</b>	<b>PACKAGE MECHANICAL DATA</b>	<b>18</b>
<b>4</b>	<b>SELECTING SENSE RESISTORS</b>	<b>9</b>	9.1	DIMENSIONAL DRAWINGS QFN20	18
<b>5</b>	<b>PROTECTION AND DIAGNOSTICS</b>	<b>10</b>	9.2	PACKAGE CODES	19
5.1	OVERTEMPERATURE PROTECTION	10	<b>10</b>	<b>DESIGNED FOR SUSTAINABILITY</b>	<b>20</b>
5.2	SHORT PROTECTION	10	<b>11</b>	<b>TABLE OF FIGURES</b>	<b>20</b>
5.3	DIAGNOSTIC OUTPUT	11	<b>12</b>	<b>REVISION HISTORY</b>	<b>21</b>
<b>6</b>	<b>ABSOLUTE MAXIMUM RATINGS</b>	<b>12</b>	<b>13</b>	<b>REFERENCES</b>	<b>21</b>
<b>7</b>	<b>ELECTRICAL CHARACTERISTICS</b>	<b>12</b>			

# 1 Principles of Operation

The TMC6300 low voltage motor driver is intended for battery-operated, space- and standby-power-critical driver applications. It is optimized for BLDC motor control, as well as control of other magnetic actuators. Each MOSFET of each half-bridge can be individually switched on and off. Internal break-before-make-(BBM)-logic ensures that no cross-conduction occurs. With sufficient supply capacitors, dual AA batteries can be drained down to typically 2.0V (voltage must not drop below 1.8V).

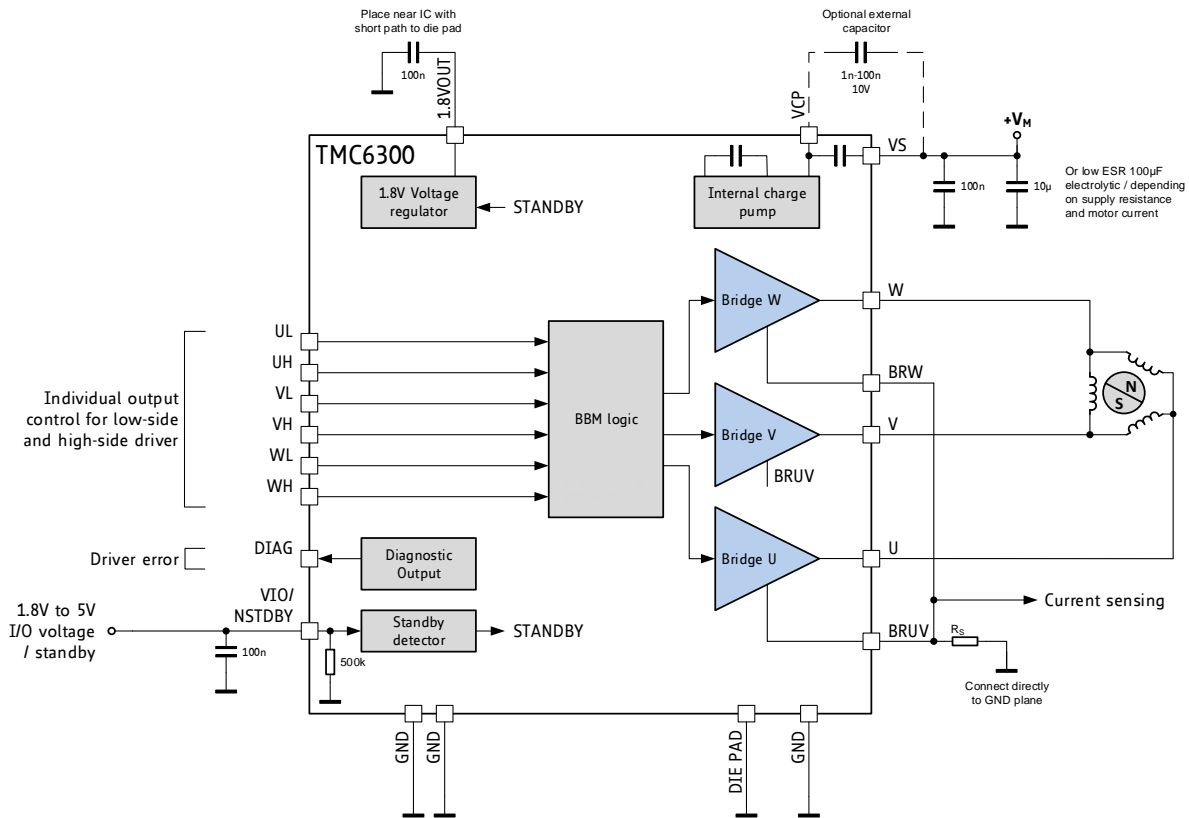

Figure 1.1 TMC6300 basic application block diagram for 3-Phase motors

## 2 Pin Assignment

The TMC6300 comes in a tiny package in order to fit miniaturized devices.

### 2.1 Package Outline

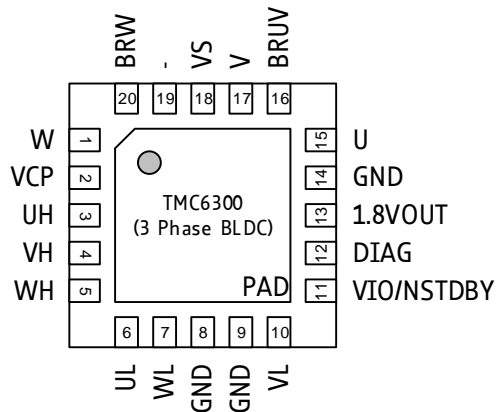

Figure 2.1 TMC6300 Pinning Top View Stepper Driver – QFN20, 3x3mm<sup>2</sup>, 0.4mm pitch

### 2.2 Signal Descriptions

Pin	Number	Type	Function
W	1		Bridge W output
VCP	2		Charge pump voltage. Optionally tie to VS using 1nF to 100nF capacitor. May be left unconnected.
UH	3	DI	Bridge U high-side control (1=high-side on)
VH	4	DI	Bridge V high-side control (1=high-side on)
WH	5	DI	Bridge W high-side control (1=high-side on)
UL	6	DI	Bridge U low-side control (1=low-side on)
WL	7	DI	Bridge W low-side control (1=low-side on)
GND	8	DI	tie to GND
GND	9	DI	tie to GND
VL	10	DI	Bridge V low-side control (1=low-side on)
VIO/NSTDBY	11		1.8V to 5V IO supply voltage for all digital pins. IC goes to standby mode and resets, when this pin is pulled to GND.
DIAG	12	DO	Diagnostic output. High level upon driver error. Reset by VIO cycle.
1.8VOUT	13		Output of internal 1.8V regulator. Attach 100nF ceramic capacitor to GND near to pin for best performance. Provide the shortest possible loop to the GND pad.
GND	14		GND. Connect to GND plane near pin.
U	15		Bridge U output
BRUV	16		Foot point of bridges U and V. Connect to GND directly, or via a sense resistor.
V	17		Bridge V output
VS	18		Bridge supply voltage. Provide filtering capacity >10μF near pin with shortest possible loop to GND pad.
-	19		Leave this pin open
BRW	20		Foot point of bridge W. Connect to GND directly, or via a sense resistor.
Exposed die pad	-		Connect the exposed die pad to a GND plane. Provide as many as possible vias for heat transfer to GND plane.

## 3 Sample Circuits

The sample circuits show the connection of external components in different operation and supply modes. The connection of the microcontroller is left out for clarity.

### 3.1 Standard Application Circuit

The 3-phase driver offers three half-bridges with individual enable signals for low-side and high-side. It allows driving a PMSM- or a BLDC-motors. In case a current measurement is desired, a common foot point shunt resistor can be added. Keep voltage drop in this resistor to maximum 400mV for normal operation. Take care to keep power supply ripple due to chopper operation at a few 100mV, max., especially when low voltage operation is desired. Use a ceramic, or low ESR capacitors for filtering the power supply. The capacitors need to cope with the current ripple caused by chopper operation. A minimum capacity of 100 $\mu$ F electrolytic, or 10 $\mu$ F ceramic capacitor near the driver is recommended to keep ripple low. Actual demand will depend on the internal power supply resistance and the desired motor current. VCC\_IO can be supplied from a separate supply, e.g. a 3.3V regulator, or be driven by a microcontroller port pin. If more than two bridges are switched on at the same time (within 1 $\mu$ s), a capacitor on pin VCP is recommended. The diagnostic output signals any overcurrent or overtemperature condition. The motor driver automatically restarts after power-up, or after cycling VIO\_NSTDBY pin.

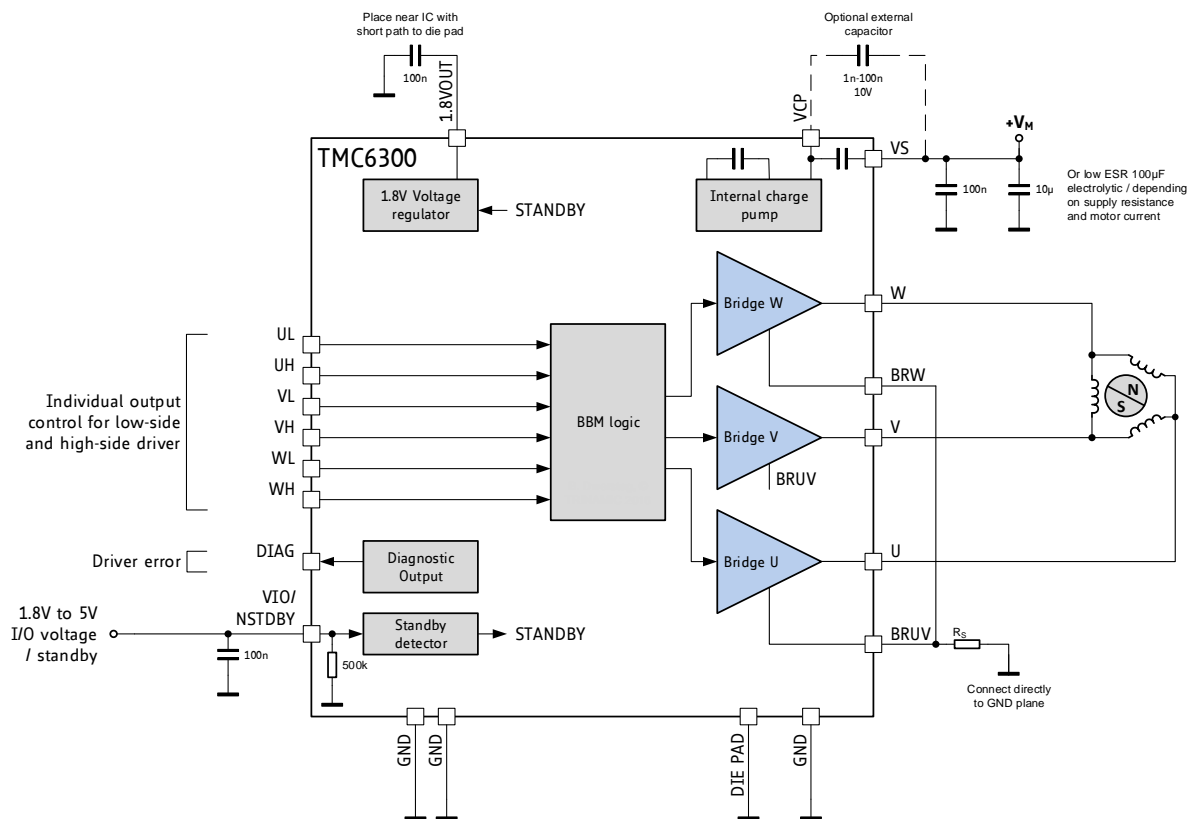
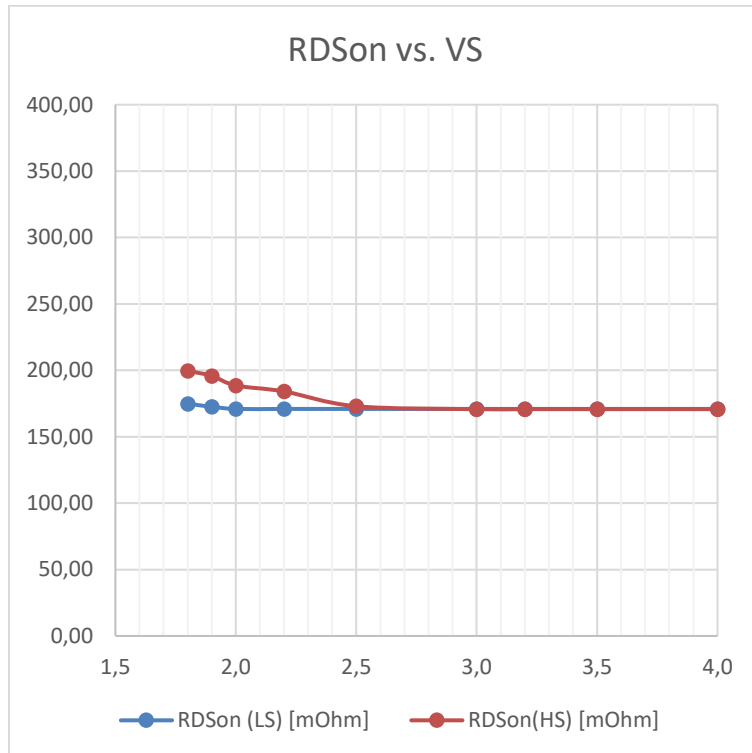

Figure 3.1 3-Phase Motor Driver

## 3.2 Highly Efficient Driver

The TMC6300 integrates a highly efficient power stage, offering low  $R_{DSon}$  even at low supply voltages, due to its internal charge pump. This enables high motor current drive capability and low power dissipation for battery powered applications.



**Figure 3.2 RDSon Variation over Supply Voltage**

When operating at a high motor current, the driver power dissipation due to MOSFET switch on-resistance significantly heats up the driver. This power dissipation will significantly heat up the PCB cooling infrastructure, if operated at an increased duty cycle. This in turn leads to a further increase of driver temperature. An increase of temperature by about 100°C increases MOSFET resistance by roughly 50%. This is a typical behavior of MOSFET switches. Therefore, under high duty cycle, high load conditions, thermal characteristics have to be carefully taken into account, especially when increased environment temperatures are to be supported. Refer the thermal characteristics and the layout hints for more information. As a thumb rule, thermal properties of the PCB design become critical for the tiny QFN 3mm x 3mm package at or above 1.4A motor current for increased periods of time. For currents above 1.4A, a 4-layer PCB layout with 5 via contact of the die attach pad to the GND plane is required. Keep in mind that resistive power dissipation raises with the square of the motor current. On the other hand, this means that a small reduction of motor current significantly saves heat dissipation and energy.

Pay special attention to good thermal properties of your PCB layout, when going for 1.4A current or more.

### 3.3 Low Power Standby

Battery powered applications, and mains powered applications conforming to energy saving rules, often require a standby operation, where the power-supply remains on, but current draw goes down to a low value. Control TMC6300 standby operation by the VIO\_NSTDBY pin:

Switch off the I/O voltage by pulling this pin to GND. At the same time make sure, that no digital input pin is at a high level. An input level above VIO\_NSTDBY would hinder pulling down VIO\_NSTDBY, due to the ESD protection diodes in each digital I/O pin. These diodes clamp each input to a level between GND and the IO supply voltage VIO\_NSTDBY. Prior to going to standby, stop the motor and go to a low coil current condition, or switch off the motor driver completely.

### 3.4 Very Low I/O Voltage Operation

In cases, where an I/O voltage of 1.8V (or even lower, due to tolerance) is to be used, the VIO undervoltage threshold level might be too high, to safely release the TMC6300 from reset state. A simple way to avoid the need for an additional I/O voltage regulator (e.g. 2V type), is to use the internal 1.8V regulator to self-supply the TMC6300 VIO pin. In order to allow power-up, the voltage on pin at VIO/NSTDBY has to be forced to min. 1.4V. In order to go back to low power standby, pull it down to less than 0.6V. A PNP transistor gives a low resistive switch to supply VIO.

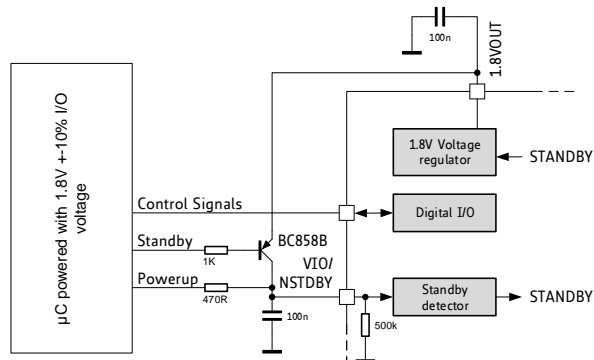

Figure 3.3 Additional Circuit for I/O voltage <1.80V



## 4 Selecting Sense Resistors

A sense resistor allows current measurement of the motor using an external ADC, in order to control or limit motor torque. Additionally, the sense resistor will help to make low-side switch overcurrent protection in the IC more sensitive, because the overcurrent protection measures the sum of the voltage drop over the sense resistor and the internal MOSFET  $R_{DS(on)}$ .

Select the sense resistor to get the best possible measurement range for the desired peak motor current. The following table shows examples for the sense resistor selection based on the desired (peak) motor coil current. The sense resistors are selected in a way, that the voltage drop stays at 200-300mV, which is well below the maximum recommended voltage of 400mV.

CHOICE OF $R_{SENSE}$ AND RESULTING MAX. MOTOR CURRENT	
$R_{SENSE}$ [ $\Omega$ ]	maximum motor coil current [A]
1.50	0.2
1.00	0.3
0.75	0.4
0.50	0.6
330m	0.8
270m	1.0
220m	1.2
150m	1.6
120m	2.0
100m	2.0 (limited by driver max. ratings)

Sense resistors should be carefully selected. The full motor current flows through the sense resistors. Due to chopper operation the sense resistors see pulsed current from the MOSFET bridges. Therefore, a low-inductance type such as film or composition resistors is required to prevent voltage spikes causing ringing on the sense voltage inputs leading to unstable measurement results. Also, a low-inductance, low-resistance PCB layout is essential. A massive ground plane is best. Please also refer to layout considerations in chapter 8.

### *Attention*

A compact layout with massive ground plane is best to avoid parasitic resistance effects.

## 5 Protection and Diagnostics

The TMC6300 drivers supply a complete set of protection capabilities, like short to GND protection, short to VS protection and undervoltage detection.

### 5.1 Overtemperature Protection

The driver integrates a two-level temperature sensor (pre-warning and thermal shutdown) for protection of the IC against excess heat. Heat is mainly generated by the motor driver stages. Most critical situations, where the driver MOSFETs could be overheated, are avoided by the short to GND protection. The thermal shutdown is just an emergency measure and temperature rising to the shutdown level should be prevented by design.

TEMPERATURE THRESHOLDS	
Temperature Level	Comment
150°C	This value is relatively safe to switch off the driver stage before the IC can be destroyed by overheating. On a large PCB, the power MOSFETs reach roughly 150°C peak temperature when the temperature detector is triggered with this setting.
120°C	Temperature level for release of overtemperature shutdown. This avoids high-frequency cycling of the overtemperature shutdown.

#### Attention

Overtemperature protection cannot in all cases avoid thermal destruction of the IC. In case the rated motor current is exceeded, excess heat generation can quickly heat up the driver before the overtemperature sensor can react. This is due to a delay in heat conduction over the IC die.

After triggering the overtemperature sensor (*ot* flag), the driver remains switched off until the system temperature falls below the pre-warning level (*otpw*) to avoid continuous heating to the shutdown level.

### 5.2 Short Protection

The TMC6300 power stages are protected against a short circuit condition by an additional measurement of the current flowing through each of the power stage MOSFETs. This is important, as most short circuit conditions result from a motor cable insulation defect, e.g. when touching the conducting parts connected to the system ground. The short detection is protected against spurious triggering, e.g. by ESD discharges, by retrying three times before switching off the motor. The sensitivity of the low side short protection can be increased by adding a sense resistor.

Once a short condition is safely detected, all driver bridges become switched off, and the DIAG output becomes set. In order to restart the motor, disable and re-enable the driver. Note, that short protection cannot protect the system and the power stages for all possible short events, as a short event is rather undefined and a complex network of external components may be involved. Therefore, short circuits should basically be avoided.

#### Attention

Short protection is an emergency measure and not designed for regular use, nor can it protect the IC and motor from destruction in all cases. The short current limit typically exceeds the absolute maximum values of the driver MOSFETs and thus is not a repetitive value. As a short circuit is a rather undefined event, which may be coupled to high inductive voltage spikes, protection cannot be guaranteed in all cases.

### 5.3 Diagnostic Output

The diagnostic output DIAG provides important status information. An active DIAG output shows that the driver cannot work normally. Figure 5.1 shows the signals controlling the output.

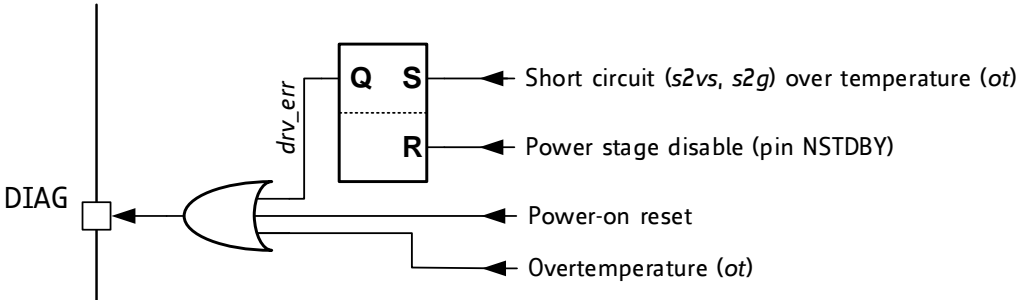

Figure 5.1 DIAG output

## 6 Absolute Maximum Ratings

The maximum ratings may not be exceeded under any circumstances. Operating the circuit at or near more than one maximum rating at a time for extended periods shall be avoided by application design.

Parameter	Symbol	Min	Max	Unit
Supply voltage operating with inductive load *)	$V_{VS}$	-0.5	11.2	V
Supply and bridge voltage max. *)	$V_{VMAX}$		13.2	V
I/O supply voltage	$V_{VIO}$	-0.5	5.5	V
digital supply voltage	$V_{1V8OUT}$	-0.5	1.95	V
Logic input voltage	$V_I$	-0.5	$V_{VIO}+0.5$	V
MODE input voltage (Do not exceed both, VCC_IO and 5VOUT by more than 10%, as this enables a test mode)	$V_{VREF}$	-0.5	6	V
Maximum current to / from digital pins and analog low voltage I/Os	$I_{IO}$		+/-10	mA
1.8V regulator output current (internal plus external load)	$I_{SVOUT}$		20	mA
Maximum mean or DC current per bridge MOS at $T_J < 110^\circ\text{C}$	$I_{OxDC}$		1.0	A
Power bridge repetitive output current	$I_{Ox}$		2.0	A
Maximum VS current	$I_{VS}$		2.8	A
Maximum BRx current	$I_{Ox}$		2.0	A
Junction temperature	$T_J$	-50	150	$^\circ\text{C}$
Storage temperature	$T_{STG}$	-55	150	$^\circ\text{C}$
ESD-Protection for handling (Human body model, HBM)	$V_{ESD}$		1.5	kV

\*) Stray inductivity of GND and VS connections will lead to ringing of the supply voltage when driving an inductive load. This ringing results from the fast switching slopes of the driver outputs in combination with reverse recovery of the body diodes of the output driver MOSFETs. Even small trace inductivities as well as stray inductivity of sense resistors can easily generate a few volts of ringing leading to temporary voltage overshoot. This should be considered when working near the maximum voltage.

## 7 Electrical Characteristics

### 7.1 Operational Range

Parameter	Conditions	Symbol	Min	Max	Unit
Junction temperature		$T_J$	-40	125	$^\circ\text{C}$
Supply voltage		$V_{VS}$	2	11	V
Supply & IO voltage battery empty limit		$V_{VS}$	1.8		V
I/O supply voltage		$V_{VIO}$	2	5.25	V
RMS current per output for continuous operation (value for design guideline)	$V_{VS} < 2.1\text{V}$	$I_{RMS}$	0.1	0.8	A
	$V_{VS} \geq 2.1\text{V}$			1.0	
	$V_{VS} \geq 2.2\text{V}$			1.2	
RMS motor coil current (chopper operation)	$V_{VS} \geq 2.5\text{V}$ $T_J < 110^\circ\text{C}$	$I_{RMS}$		1.4	A
Max. output current duty cycle limited	$T_J < 100^\circ\text{C}$	$I_{Ox}$		2.0	A
Sum of output current (VS supply pin current)		$I_{VS}$		2.4	A

## 7.2 DC and Timing Characteristics

DC characteristics contain the spread of values guaranteed within the specified supply voltage range unless otherwise specified. Typical values represent the average value of all parts measured at +25°C. Temperature variation also causes stray to some values. A device with typical values will not leave Min/Max range within the full temperature range.

Power supply current		DC-Characteristics				
		$V_{VS} = 8.0V, V_{VIO}=3.3V$				
Parameter	Symbol	Conditions	Min	Typ	Max	Unit
Total supply current, operating, $I_{VS}$	$I_{VS}$	35kHz chopper, no load		7	12	mA
IO supply current operating	$I_{VIO}$	no load on outputs, inputs at $V_{IO}$ or GND		60	200	$\mu A$
Total supply current, low-power standby, $I_{VS}$	$I_{VS}$	$V_{VCC\_IO} < 0.2V$		0.03	1	$\mu A$

Motor driver section		DC- and Timing-Characteristics				
		$V_{VS} = 8.0V, V_{VIO}=3.3V$				
Parameter	Symbol	Conditions	Min	Typ	Max	Unit
RDS <sub>ON</sub> lowside MOSFET	$R_{ONL}$	measure at 100mA, 25°C, $V_{VS} \geq 3.2V$ *)		0.17	0.25	$\Omega$
RDS <sub>ON</sub> highside MOSFET	$R_{ONH}$	measure at 100mA, 25°C, $V_{VS} \geq 3.2V$ *)		0.17	0.25	$\Omega$
slope, rising	$t_{SLPRISE}$	value for reference		20		ns
slope, falling	$t_{SLPFALL}$	value for reference		7		ns
Current sourcing, driver off	$I_{Oidle}$	$O_{XX}$ pulled to GND	6	13	30	$\mu A$
Recommended / max. VS power-up slope to >5V	$VS_{RAMP}$	Hint: Normally satisfied due to ext. capacitor on VS.		<0.33 rcd.	1	V/ $\mu S$

Charge pump		DC-Characteristics				
Parameter	Symbol	Conditions	Min	Typ	Max	Unit
Charge pump output voltage (mean)	$V_{VCP}-V_{VS}$	$V_{VS} \geq 3.5V$	4.2	5.1	5.7	V

Linear regulator		DC-Characteristics				
		$V_{VS} = 8.0V, V_{VIO}=3.3V$				
Parameter	Symbol	Conditions	Min	Typ	Max	Unit
Output voltage	$V_{5VOUT}$	$I_{1V8OUT} = 0mA$ $T_J = 25^\circ C$	1.65	1.8	1.95	V

Switching Delay		Timing-Characteristics				
Parameter	Symbol	Conditions	Min	Typ	Max	Unit
Change on digital input to output switching	$t_{DLY}$	The inputs are sampled with an internal 12MHz (9-15MHz) clock.		250	500	ns
Matching of delay time between two signals	$t_{DLYMATCH}$			80		ns

Detector levels		DC-Characteristics				
		$V_{VS} = 8.0V, V_{VIO}=3.3V$				
Parameter	Symbol	Conditions	Min	Typ	Max	Unit
$V_{VS}$ undervoltage threshold for RESET	$V_{UV\_VS}$	$V_{VS}$ rising		1.8	2	V
		$V_{VS}$ falling	1.8	1.6		V
$V_{VIO}$ undervoltage threshold for RESET	$V_{UV\_VIO}$	$V_{VIO}$ rising			1.8	V
		$V_{VIO}$ falling	1.7			
$V_{VIO}$ low power standby input voltage	$V_{UV\_VIOHYST}$				0.4	V
Worst case power-up delay time		$V_{VS} = 2.0V, V_{VIO}=1.8V$			500	$\mu s$
Short to GND detector threshold ( $V_{VS} - V_{Ox}$ )	$V_{OS2G}$	$V_{VS} \geq 3.5V$ required for operation	0.5	0.8		V
Short to VS detector threshold ( $V_{Ox}$ )	$V_{OS2G}$		1.0	1.2	1.6	V
Short detector delay (high side / low side switch on to short detected)	$t_{S2G}$			1		$\mu s$
Overtemperature prewarning 120°C	$t_{OTPW}$	Temperature rising	100	120	140	°C
Overtemperature shutdown 150°C	$t_{OT150}$	Temperature rising	135	150	170	°C

Digital pins		DC-Characteristics				
Parameter	Symbol	Conditions	Min	Typ	Max	Unit
Input voltage low level	$V_{INLO}$		-0.3		$0.3 V_{VIO}$	V
Input voltage high level	$V_{INHI}$		$0.7 V_{VIO}$		$V_{VIO}+0.3$	V
Input Schmitt trigger hysteresis	$V_{INHYST}$	$V_{VIO}=3.3V$		$0.12 V_{VIO}$		V
Output voltage low level	$V_{OUTLO}$	$I_{OUTLO} = 2mA, V_{VIO}=3.3V$			0.2	V
Output voltage high level	$V_{OUTH}$	$I_{OUTH} = -2mA, V_{VIO}=3.3V$	$V_{VIO}-0.2$			V
Input leakage current	$I_{LEAK}$		-1		1	$\mu A$
Digital pin capacitance	C	*)		3.5		pF

\*) These parameters are not measured in series test, guaranteed by design

### 7.3 Thermal Characteristics

The following table shall give an idea on the thermal resistance of the package. The thermal resistance for a four-layer board will provide a good idea on a typical application. Actual thermal characteristics will depend on the PCB layout, PCB type and PCB size. The thermal resistance will benefit from thicker CU (inner) layers for spreading heat horizontally within the PCB. Also, air flow will reduce thermal resistance.

A thermal resistance of 40K/W for a typical board means, that the package is capable of continuously dissipating 1W at an ambient temperature of 85°C with the die temperature staying below/at 125°C. Note, that a thermally optimized layout is required.

Parameter	Symbol	Conditions	Typ	Unit
Typical power dissipation	$P_D$	2A current from one half-bridge output to a second output, 35kHz chopper, 11V, 60°C peak surface of package	1	W
Typical power dissipation	$P_D$	0.7A current in block commutation, 35kHz chopper, 11V, 45°C peak surface of package	0.5	W
Thermal resistance junction to ambient on a multilayer board	$R_{TMJA}$	Dual signal and two internal power plane board (2s2p) as defined in JEDEC EIA JESD51-5 and JESD51-7 (FR4, 35µm CU, 70mm x 133mm, d=1.5mm)	40	K/W
Thermal resistance junction to case	$R_{TJC}$	Junction to heat slug of package	7	K/W

**Table 7.1 Thermal characteristics**

## 8 Layout Considerations

### 8.1 Exposed Die Pad

The TMC6300 uses its die attach pad to dissipate heat from the drivers and the linear regulator to the board. For best electrical and thermal performance, use a reasonable amount of solid, thermally conducting vias between the die attach pad and the ground plane. The printed circuit board should have a solid ground plane spreading heat into the board and providing for a stable GND reference.

### 8.2 Wiring GND

All signals of the TMC6300 are referenced to their respective GND. Directly connect all GND pins under the device to a common ground area (GND and die attach pad). The GND plane right below the die attach pad should be treated as a virtual star point. For thermal reasons, the PCB top layer shall be connected to a large PCB GND plane spreading heat within the PCB.

#### *Attention*

Especially the sense resistors are susceptible to GND differences and GND ripple voltage. Optimally place the resistor close to the IC, with one or more vias to the GND plane.

### 8.3 Supply Filtering

The 1.8VOUT output voltage ceramic filtering capacitor (100nF recommended) should be placed as close as possible to the 1.8VOUT pin, with its GND return going directly to the die pad or the nearest GND pin. This ground connection shall not be shared with other loads or additional vias to the GND plane. Use as short and as thick connections as possible.

The motor supply pins VS should be decoupled with a ceramic, or a ceramic plus an electrolytic capacitor (47 $\mu$ F or larger is recommended, depending on the motor coil current). Place the capacitors close to the device.

Take into account that the switching motor coil outputs have a high dV/dt. Thus, capacitive stray into high resistive signals can occur, if the motor traces are near other traces over longer distances.



## 8.4 Layout Example

### Schematic

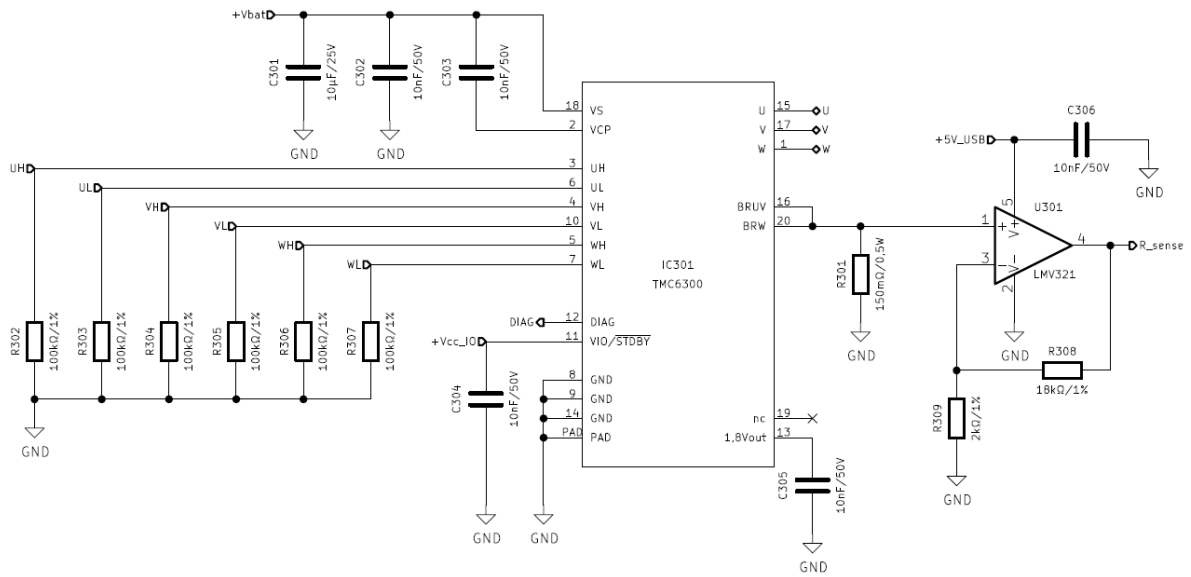

### Placement (Excerpt)

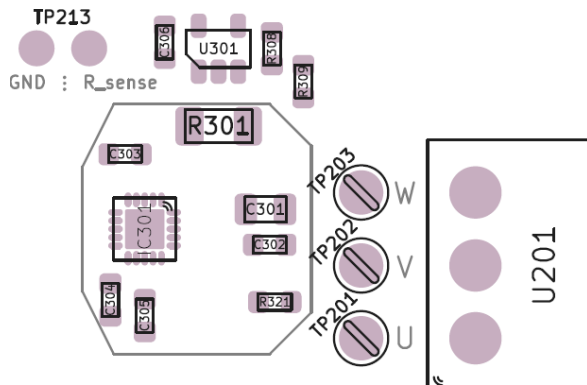

### Top Layout (Excerpt, showing die pad vias)

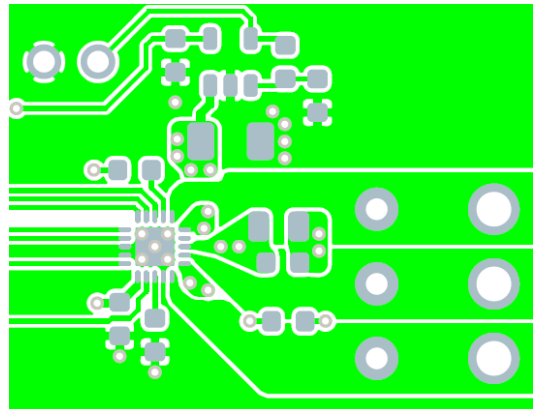

The complete schematics and layout data for all evaluation boards are available on the TRINAMIC website.

## 9 Package Mechanical Data

### 9.1 Dimensional Drawings QFN20

Attention: Drawings not to scale.

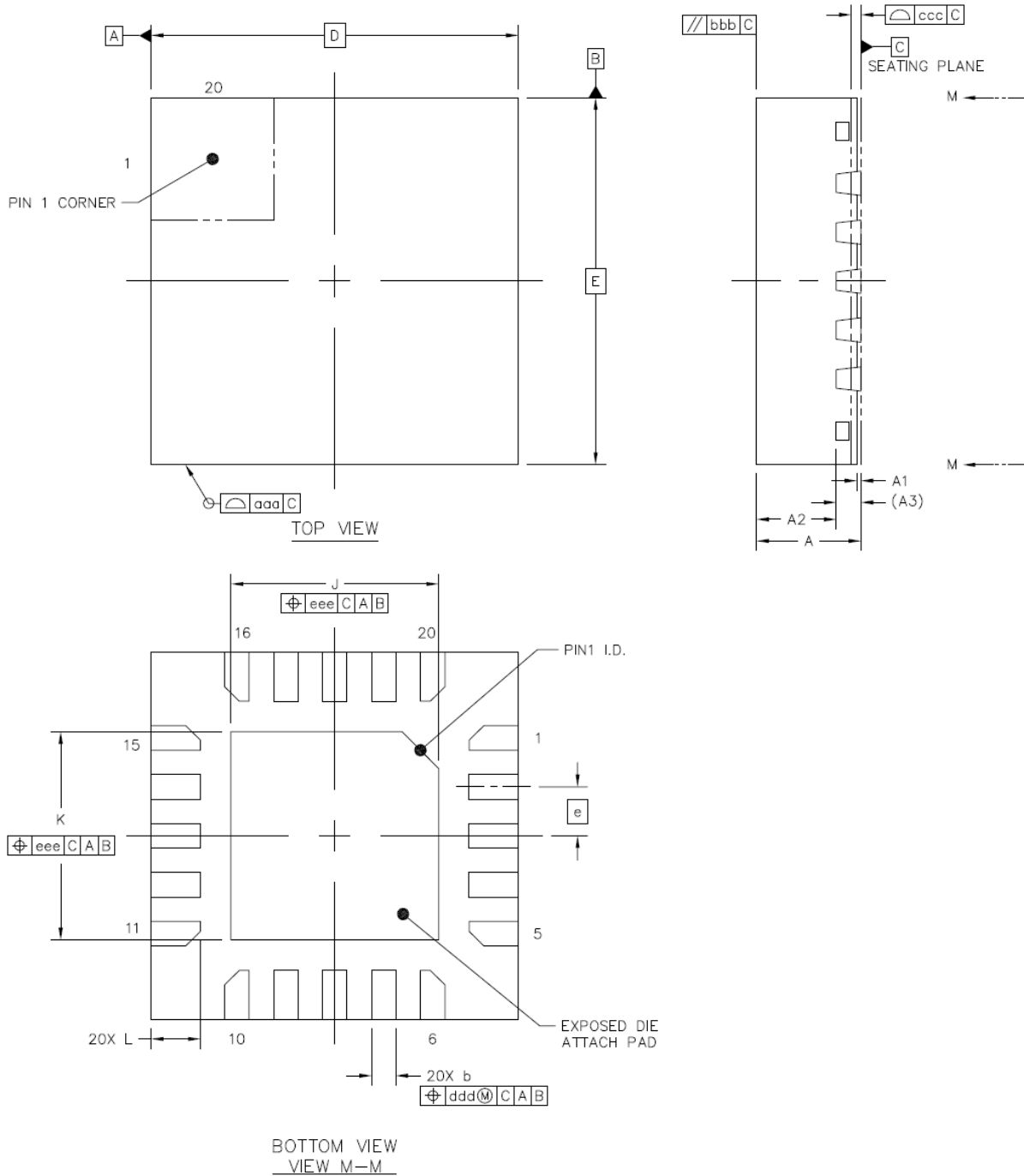

Figure 9.1 Dimensional drawings QFN20

Parameter	[mm]	Ref	Min	Nom	Max
total thickness		A	0.8	0.85	0.9
stand off		A1	0	0.035	0.05
mold thickness		A2		0.65	0.67
lead frame thickness		A3		0.203	
Lead width		b	0.15	0.2	0.25
body size X		D		3.0	
body size Y		E		3.0	
lead pitch		e		0.4	
exposed die pad size X		J	1.6	1.7	1.8
exposed die pad size Y		K	1.6	1.7	1.8
lead length		L	0.35	0.4	0.45
package edge tolerance		aaa			0.1
mold flatness		bbb			0.1
coplanarity		ccc			0.08
lead offset		ddd			0.1
exposed pad offset		eee			0.1

## 9.2 Package Codes

Type	Package	Temperature range	Code & marking
TMC6300-LA	QFN20 (RoHS)	-40°C ... +125°C	(TMC logo) 6300

## 10 Designed for Sustainability

Sustainable growth is one of the most important and urgent challenges today. We at Trinamic try to contribute by designing highly efficient IC products, to minimize energy consumption, ensure best customer experience and long-term satisfaction by smooth and silent run, while minimizing the demand for external resources, e.g. for power supply, cooling infrastructure, reduced motor size and magnet material by intelligent control interfaces and advanced algorithms.

Please help and design efficient and durable products made for a sustainable world.

## 11 Table of Figures

FIGURE 1.1 TMC6300 BASIC APPLICATION BLOCK DIAGRAM FOR 3-PHASE MOTORS.....	4
FIGURE 2.1 TMC6300 PINNING TOP VIEW STEPPER DRIVER – QFN20, 3X3MM <sup>2</sup> , 0.4MM PITCH.....	5
FIGURE 3.1 3-PHASE MOTOR DRIVER .....	6
FIGURE 3.2 R <sub>DS(on)</sub> VARIATION OVER SUPPLY VOLTAGE.....	7
FIGURE 3.3 ADDITIONAL CIRCUIT FOR I/O VOLTAGE <1.80V .....	8
FIGURE 5.1 DIAG OUTPUT.....	11
FIGURE 9.1 DIMENSIONAL DRAWINGS QFN20.....	18

## 12 Revision History

Version	Date	Author	Description
V1.00	2019-Aug-02	BD <small>BD= Bernhard Dwersteg</small>	Minor changes
V1.01	2019-Nov-06	BD	Minor wording, added chapter on sustainability, added chapter on low I/O voltage operation
V1.02	2020-Apr-02	BD	Added new TMC6300-EVAL
V1.03	2020-May-19	BD	Updated Logo
V1.04	2020-Jun-02	BD	Complemented operational range, added information on limitations of short protection

Table 12.1 Document Revisions

## 13 References

[TMC6300-EVAL] TMC6300 Evaluation board: Manuals, software and PCB data available on [www.trinamic.com](http://www.trinamic.com)