

THIS DRAWING IS UNPUBLISHED  
RELEASED FOR PUBLICATION  
COPYRIGHT 20 BY - ALL RIGHTS RESERVED.

REVISIONS					
P	LTR	DESCRIPTION	DATE	DWN	APVD
B	4	REVISED PER ECO-11-005030	11MAR2011	RK	HMR
C		REVISED PER ECO-13-019231	09DEC2013	DR	RB

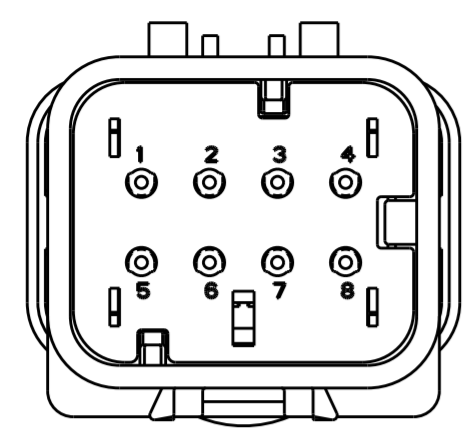

776538-2  
SCALE 2:1

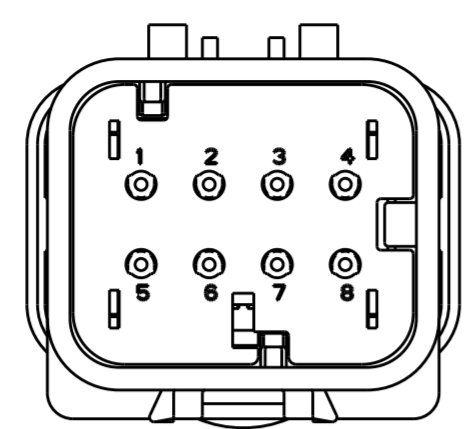

776538-3  
SCALE 2:1

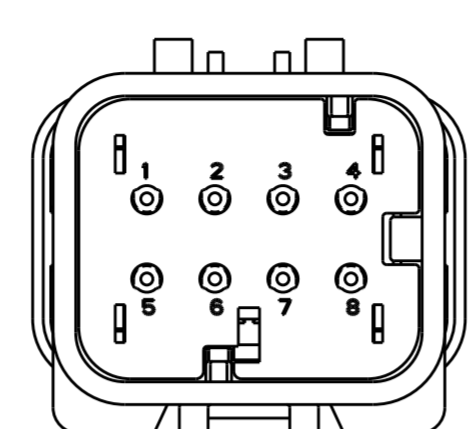

776538-4  
SCALE 2:1

- ① MATERIAL: 15% GLASS FILLED THERMOPLASTIC  
COLOR: BLACK
  - ② MATERIAL: 15% GLASS FILLED THERMOPLASTIC  
COLOR: (SEE TABLE)
  - ③ MATERIAL: SILICONE  
COLOR: RUST
4. RECOMMENDED WIRE DIAMETER RANGE IS 1.30 TO 2.54mm

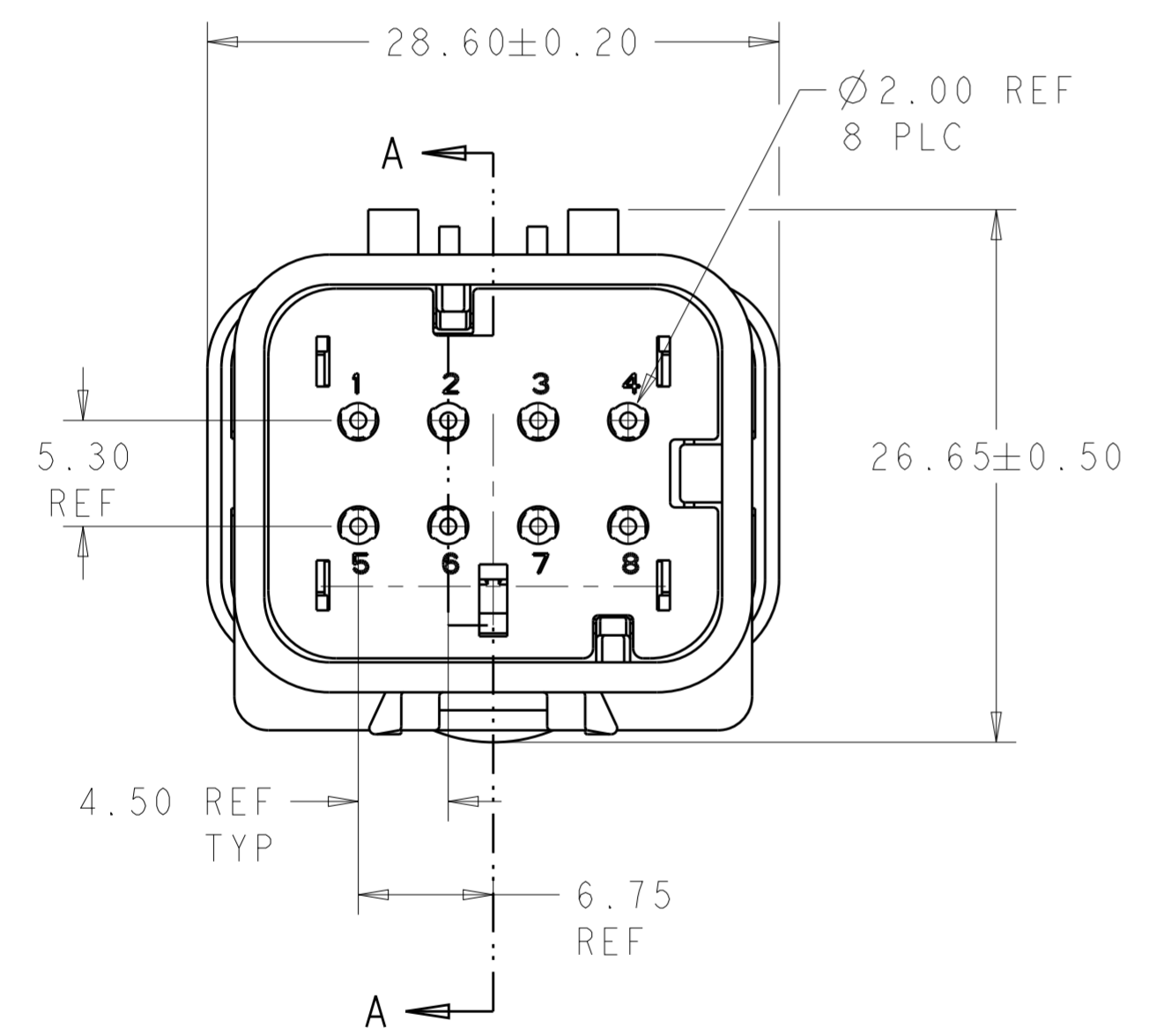

776538-1 SHOWN

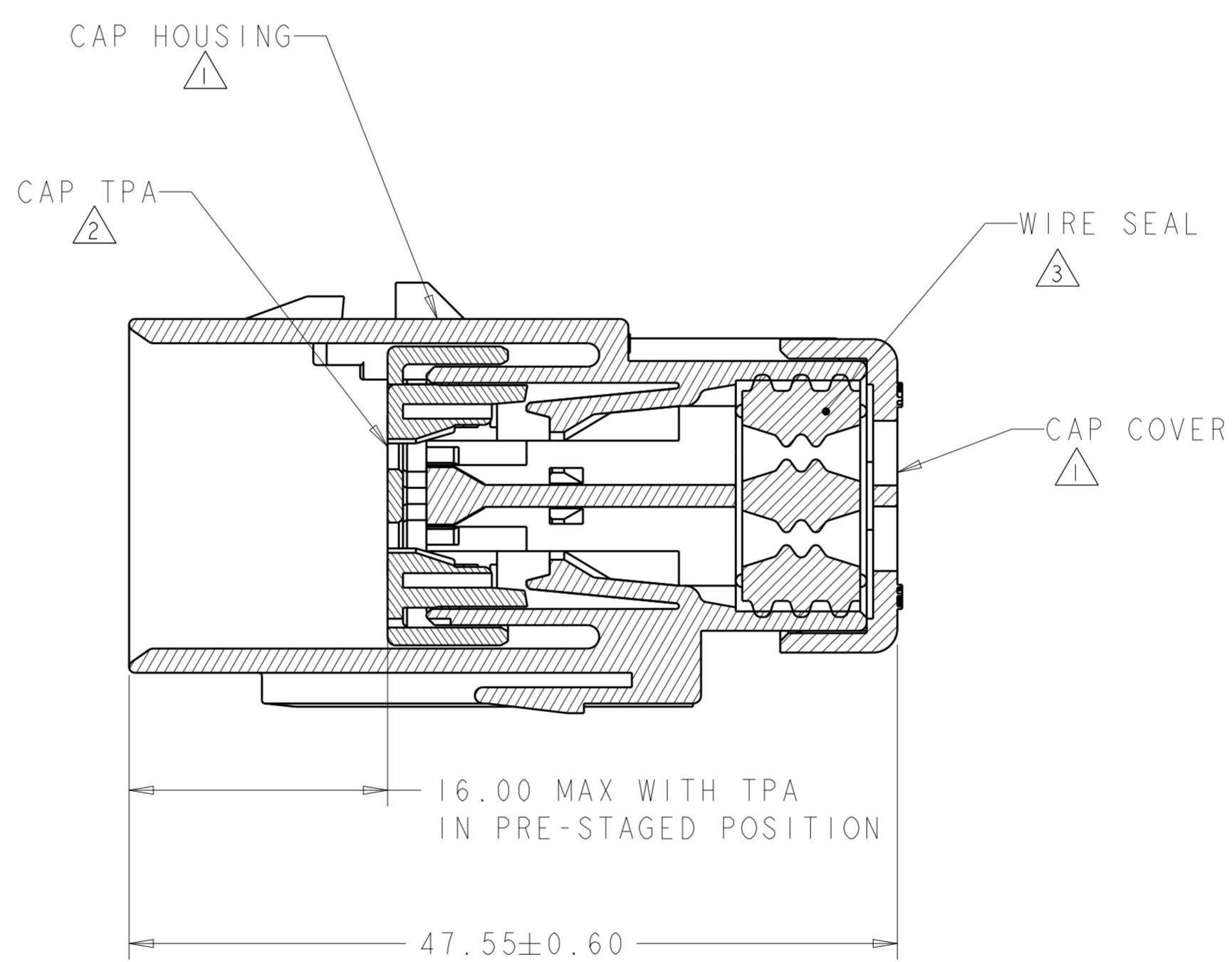

SECTION A-A

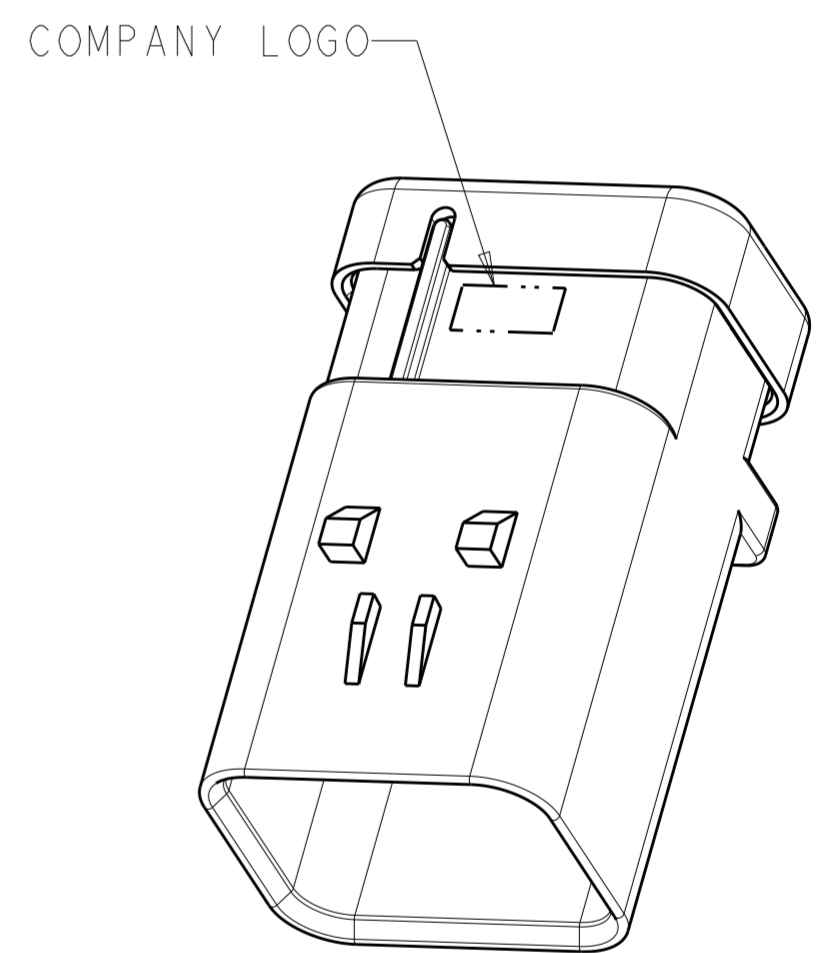

SCALE 2:1

GREEN	776538-4
YELLOW	776538-3
GRAY	776538-2
RED	776538-1
TPA COLOR	PART NUMBER

THIS DRAWING IS A CONTROLLED DOCUMENT.		DWN Y. PETERSON 17DEC02	TE Connectivity	
DIMENSIONS: mm		CHK R. GREINER 17DEC02		
TOLERANCES UNLESS OTHERWISE SPECIFIED:		APVD R. GREINER 17DEC02		
0 PLC ± 1 PLC ± 2 PLC ± 3 PLC ± 4 PLC ± ANGLES ± FINISH -		PRODUCT SPEC 108-2184 APPLICATION SPEC 114-13065 WEIGHT 17.5 Customer Drawing		
NAME			CAP ASSEMBLY, 8 POSITION, 2 ROW, AMPSEAL 16 CONNECTOR REDUCED DIA WIRE SEAL	
SIZE			CAGE CODE	DRAWING NO
A200779			C-776538	RESTRICTED TO
SCALE 2:1			SHEET 1 OF 1	REV C