



molex®

Battery Powered Crimping Tool

Operation Manual

Order No. 63816-1000 (115V)

Order No. 63816-1050 (230V)

- Description
- Operation
- Maintenance



Table of Contents













Contents





Battery Powered Crimping Tool.....	1
Order No. 63816-1000 (115V).....	1
Order No. 63816-1050 (230V).....	1
Table of Contents	2
Section 1	6
General Description	6
1.1. Features.....	7
1.2. Principal Mechanical Parts of the 63816-1000 Battery Powered Tool.....	7
1.3. Technical Specifications	8
1.4. Delivery Check.....	8
Section 2	9
Set-Up and Adjustments	9
2.1 Set-Up.....	10
2.2 Operation.....	11
2.3 Preventive Instructions	12
Section 3	13
General Terminal Specifications and Crimping Operation	13
3.1 Scope.....	14
3.2 Crimping Terminals.....	14
Section 4	15
Preventive Maintenance	15
4.1 Periodic Cleaning.....	16
4.2 Battery and Battery Charger	17
4.3 Disposal.....	18
4.4 Warranty	18
Section 5	19
5.1 Parts List and Assembly Drawings	20
5.2 Troubleshooting.....	21

Safety Warnings and Information

	<p>Read and understand all of the instructions and safety information in this manual before operating or servicing this tool.</p> <p><u>Keep this manual available when using this tool.</u> Replacement manuals are available for download at no charge at www.molex.com.</p>
---	--

SAFETY ALERT SYMBOL	
<p>This symbol is used to call your attention to hazards or unsafe practices which could result in an injury or property damage. The signal word, defined below, indicates the severity of the hazard. The message after the signal word provides information for preventing or avoiding the hazard.</p>	
 DANGER	<p>DANGER: Indicates an imminently hazardous situation which, if not avoided, could result in death Or serious injury.</p>
 WARNING	<p>WARNING: Indicates a potentially hazardous situation which, if not avoided, could result in death or serious injury.</p>
 CAUTION	<p>CAUTION: Indicates a potentially hazardous situation which, if not avoided, may result in minor or moderate injury. CAUTION may also be used to alert against unsafe practices associated with events that could lead to personal injury.</p>

	<p> WARNING</p> <p>Always wear proper eye protection when Operating or servicing this tool.</p> <p>Failure to wear eye protection could result in serious eye injury from flying debris or hydraulic oil.</p>		<p> WARNING</p> <p>Always wear proper ear protection when Operating or servicing this tool.</p>
	<p> WARNING</p> <p>Inspect tool and dies before use. Replace any worn or damaged parts. A damaged or improperly assembled tool can break and strike someone nearby.</p> <p>Failure to observe this warning could result in severe injury or death.</p>		<p> WARNING</p> <p>Electric shock hazard:</p> <p>This tool is not insulated. When using this unit Near energized electrical lines, use proper Personal protective equipment. Failure to observe this warning could result in severe injury or death</p>
	<p> WARNING</p> <p>Never operate, service, install, or adjust this tool without proper instruction and without first reading and understanding the instructions in this manual and all applicable manuals.</p>		<p> WARNING</p> <p>Pinch points: Keep hands away from the crimping head When crimping. Failure to observe this warning could result in severe injury or death.</p>

	<p>WARNING</p> <p>Do not use solvents or flammable liquids to clean the crimping tool.</p> <p>Solvents or flammable liquids could ignite and cause serious injury or property damage.</p>		<p>WARNING</p> <p>An incomplete crimp can cause a fire.</p> <ul style="list-style-type: none"> Use proper die, connector, and cable combinations. Improper combinations can result in an incomplete crimp. The relief valve will sound to indicate a completed crimp. If you do not hear the sound of the relief, valve the crimp is not complete. <p>Failure to observe these warnings could result in severe injury or death.</p>
	<p>WARNING</p> <p>Do not use compressed air to clean this tool. The forces created by compressed air can force debris into the tool.</p> <p>Failure to observe these precautions may result in injury or property damage.</p>		<p>WARNING</p> <p>Do not dispose of the battery in a fire. It will vent fumes and may explode.</p> <p>Failure to observe this warning could result in severe injury from harmful fumes or burns from flying debris</p>
<p>CAUTION</p> <ul style="list-style-type: none"> Do not operate the tool without the dies. Damage to the ram or crimping head can result. Do not operate with the crimping head open. Damage to the ram or seals can result. This tool is not designed for continuous use. After 100 crimping cycles, allow the crimping tool to cool down for 15 minutes. Do not place the tool in a vise. The crimping tool is designed for hand-held operation only. This tool may be used in damp or wet environments; however, we recommend air-drying the tool before use if it becomes soaked. Use this tool for the manufacturer's intended purpose only. <p>Failure to observe these precautions may result in injury or property damage</p>			
<p>CAUTION</p> <ul style="list-style-type: none"> Do not allow anything to contact the battery's terminals. Do not immerse the battery in liquid. Liquid may create a short circuit and damage the battery. If the battery is immersed, contact your service center for proper handling. Do not place the battery into a pocket, tool pouch, or tool box with conductive objects. Conductive objects may create a short circuit and damage the battery. Do not place a battery on moist ground or grass. Moisture may create a short circuit and damage the battery. <p>Failure to observe these precautions may result in injury or property damage.</p>			
<p>CAUTION</p> <ul style="list-style-type: none"> Do not store the battery at more than 60 °C (140 °F). Damage to the battery can result. Do not use another manufacturer's charger. Other manufacturers' chargers may overcharge and damage the battery. Do not attempt to open the battery. It contains no user-serviceable parts. Failure to observe these precautions may result in injury or property damage. 			
<p>CAUTION</p> <p>Never perform any service or maintenance other than as described in this manual.</p> <p>Never modify, alter or misuse the equipment</p> <p>Molex crimp specifications are valid only when used with Molex terminals, applicators and tooling.</p> <p>Failure to observe this precaution may result in injury and property damage.</p>			

Tooling Technical Assistance

Molex offers tooling technical assistance for customers who may need some guidance for tooling adjustments. This support can be obtained by calling either of the two numbers listed below and asking for the Molex Tooling Group.

Call Toll Free 1-800-786-6539 (US) 1-630-969-4550 (Global).

This assistance is limited to the operation and set-up of a customer's Molex tool. Questions with regard to Molex connector products or how to identify the proper tooling and/ or tooling documentation should be directed to your local Molex personnel or Customer Service Representative.

When calling for service on this tool, a copy of the Tooling Manual and Specific Application Tooling Specification (ATS) Sheet should be present and a person that is familiar with this tool should be present. Be sure the following information is supplied:

1. Customer name
2. Customer address
3. Person to contact such as (name, title, e-mail, and telephone number)
4. Power tool order number (Lease number also if applicable)
5. Serial number (Lease number also if applicable)
6. Molex Connector product order number
7. Urgency of request
8. Nature of problem

Molex Application Tooling Group

2200 Wellington Court
Lisle, IL 60532, USA
Tel: +1 (630) 969-4550
Fax: +1 (630) 505-0049

Visit our Web site at <http://www.molex.com>

Section 1

General Description

- 1.1 Features
- 1.2 Principal Mechanical Parts of the 63816-1000 Battery Powered Tool
- 1.3 Technical Specifications
- 1.4 Delivery Check

Description

The Molex Battery Powered Tool is designed to crimp large terminals with the use of interchangeable crimp heads and die kits. This tool has a trigger actuated retraction system which returns the crimping dies to the starting position after the maximum force is reached. It is equipped with a special brake that will stop the forward motion of the crimping dies when the trigger is released. The crimping head can be rotated 360° for better access in difficult working situations.

1.1. Features

- Crimps a wide range of products with interchangeable modular crimp heads or adapters and tool kits, which reduce the overall cost and provide production flexibility.
- Power crimp heads and dies are easily and quickly interchanged to reduce production down time.
- Complete portable system that allows the tool to be moved and stored easily.

1.2. Principal Mechanical Parts of the 63816-1000 Battery Powered Tool.

The Battery charger is not shown.



Figure 1-1

Item	Description	Function
1	Operating Switch	Release of the crimping process
2	Label	Type description, manufacturer information and technical data
3	Battery Release	Release Button for the battery
4	Battery	Battery Li-Ion
5	Return Lever	For opening of the die sets after the crimping process is done
6	Locking Bolts	For locking and releasing the adapter
7	Adjusting Unit Adapter	Adjusting unit for the cutting head and adapters with die sets
The serial number can be found on the housing near the battery connection		

1.3. Technical Specifications

Dimensions (without crimp heads and with battery)

Length	254mm (10.00")
Width	212.85mm (8.38")
Depth	79.25mm (3.12")
Weight with battery	3.6 kg (7.9 lbs.)

Production Rate

250 cycles per hour maximum, depending on operator skill and tool kit installed.

Battery

Voltage	14.4 V DC
Capacity	1.5 Ah Li-Ion
Charging Time	15 minutes
Crimps/battery-charge	150 at a medium force

Operating Parameters

Maximum Force	130 kN (14.6 ton-force)
Cycle Time	7 seconds
Stroke Length	18.00mm (.709")

1.4. Delivery Check

Carefully remove the Battery Powered Tool from its shipping container and determine that the following items are included in the package.

For the 63816-1000 (115V):

63816-1000	Battery Crimping Tool	1
63816-1002	Battery (2)	2
63816-1010	Charging unit	1
Carrying Case		1
TM-638161000	Operation Manual	1

For the 63816-1050 (230V):

63816-1050	Battery Crimping Tool	1
63816-1002	Battery (2)	2
63816-1010	Charging unit	1
Carrying Case		1
TM-638161000	Operation Manual	1

Section 2

Set-Up and Adjustments

- 2.1. Set-up
- 2.2. Operation
- 2.3. Preventive Instructions

2.1 Set-Up

Installing the Crimp Head



WARNING: Remove the battery from the crimping tool before installing and removing the crimp head.



CAUTION: Do not try to remove the crimp head if it is closed or under pre-load.

1. Select the appropriate power crimp head with the proper tooling kit inserted for the application needed (The crimp head and tooling kits are sold separately).
2. Switch off the battery powered crimping tool and remove the battery.

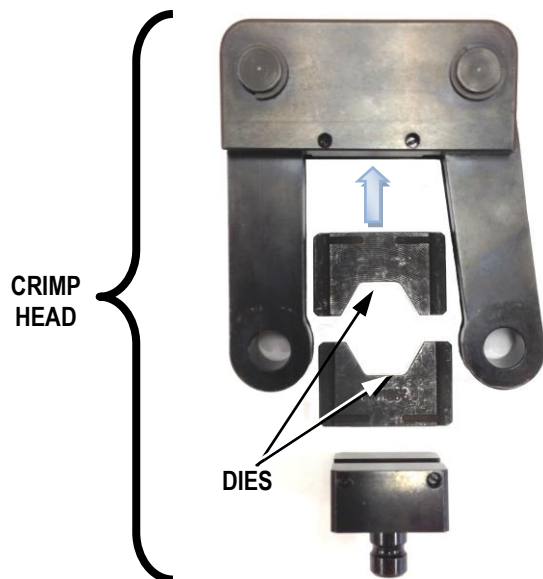

Figure2-1

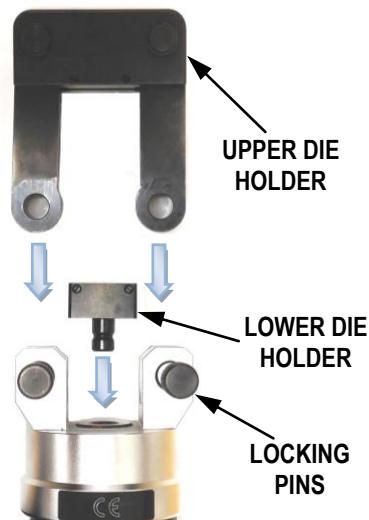

Figure 2-2

3. Install the desired crimping dies into the upper and lower crimp head components. See Figure 2.1.
4. Slide out the locking pins on the Power Crimping Tool to allow for installation of the crimp head. Then, snap the lower die holder into the mounting hole on the top of the crimping tool (dies not shown).
5. Attach the upper portion of the crimp head to the Power Crimping Tool and slide the pins back through the mating holes in the crimp head to secure it to the Power Crimping Tool. See Figure 2-2
6. Check the crimp head to insure that the locking pins are fully inserted.



WARNING: Electric shock hazard:

This tool is not insulated. When using this unit near energized electrical lines, use proper personal protective equipment.

Failure to observe this warning could result in severe injury or death



WARNING: Wear eye protection when operating or servicing this tool.

Failure to wear eye protection could result in serious eye injury from flying debris or hydraulic oil.

Install the Battery

1. Insert the battery by aligning the grey latches on the top of the battery with the arrows on the mating end of the crimping tool and then pushing upward.
2. To lock the battery in place, slide it back until the latch locks it in place.
3. When removing the battery, push the grey battery lock button while sliding the battery in the forward direction.

2.2 Operation

1. Insert the terminal into the crimp profile. See Figure 2-3.
2. Press the operating switch until the lower crimp die set drives upward and holds the terminal in position. Be careful not to crimp the terminal before loading the wire. See Figure 2-4.



Figure 2-3

3. Insert the correct stripped wire into the terminal. See Figure 2-5.
4. Press the operating switch until the crimp is completely closed (The tool will make a clicking sound when the crimping is complete).
5. Push the return lever button (see Item 5 in Figure 1) to bring the stroke back to the starting position.
6. Take the crimped terminal out of the profile. See Figure 2-6.

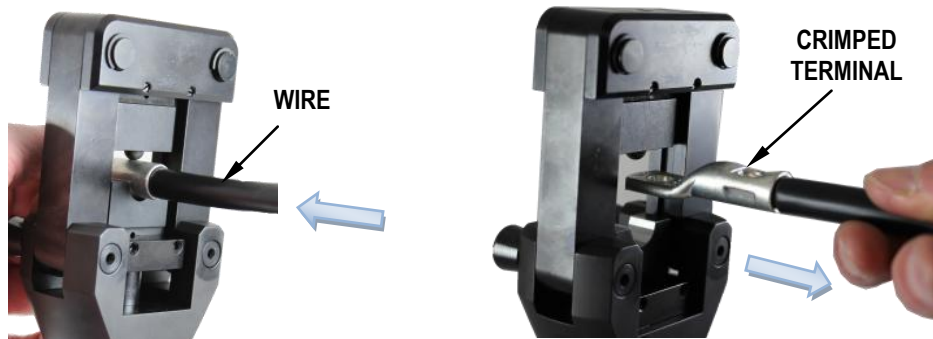

Figure 2-5

Figure 2-6

7. The crimping operation can be interrupted at any time during the cycle by releasing the trigger.
8. The crimping cycle is complete when the dies are completely closed and the maximum crimping force is reached.



Note: In case of an error or emergency, the ram can be retracted before the crimping cycle is complete. To do this, push the return lever button.



Warning: An incomplete crimp can cause a fire.

- Use proper die, connector, and cable combinations. Improper combinations can result in an incomplete crimp.
- The crimping tool will make a clicking sound to indicate a completed crimp. If you do not hear the clicking sound, the crimp is not complete. Failure to observe these warnings could result in severe injury or death.

2.3 Preventive Instructions



WARNING: Do not dispose of the battery in a fire. It will vent fumes and may explode. Failure to observe this warning could result in severe injury from harmful fumes or burns from flying debris



WARNING: Inspect tool and dies before use. Replace any worn or damaged parts. A damaged or improperly assembled tool can break and strike someone nearby. Failure to observe this warning could result in severe injury or death.

CAUTION:

- Do not operate the tool without the dies. Damage to the ram or crimping head can result.
- Do not operate with the crimping head open. Damage to the ram or seals can result.
- This tool is not designed for continuous use. After 100 crimping cycles, allow the crimping tool to cool down for 15 minutes.
- Do not place the tool in a vise. The crimping tool is designed for hand-held operation only.
- This tool may be used in damp or wet environments; however, we recommend air-drying the tool before use if it becomes soaked.
- Use this tool for the manufacturer's intended purpose only.

Failure to observe these precautions may result in injury or property damage.

CAUTION:

- Do not allow anything to contact the battery's terminals.
- Do not immerse the battery in liquid. Liquid may create a short circuit and damage the battery.
- If the battery is immersed, contact your service center for proper handling.
- Do not place the battery into a pocket, tool pouch, or tool box with conductive objects.
- Conductive objects may create a short circuit and damage the battery.
- Do not place a battery on moist ground or grass. Moisture may create a short circuit and damage the battery.

Failure to observe these precautions may result in injury or property damage.

Avoid dropping this tool. Extreme shock may damage the internal mechanism and result in malfunction of the tool.

Section 3

General Terminal Specifications and Crimping Operation

3.1. **Scope**

3.2. **Crimping terminals**

3.1 Scope

This tool is designed to crimp various Molex terminals and splices using our offering of crimping heads.

Testing

Mechanical

The tensile test, or pull test, is a means of evaluating the mechanical properties of the crimped connections. The following charts show the UL specifications for various wire sizes. The tensile strength is shown in pound-force, which indicates the minimum acceptable force to break or separate the terminal from the conductor.

Wire Size (AWG)	Tooling Color Code	*UL – 486A	**UL – 486C	***MIL-T-7928
22		8	8	
20		13	10	
18		20	10	
16		30	15	
14		50	25	
12		70	35	
10		80	40	
8	Red	90	45	225
6	Blue	100	50	300
4	Yellow	140	-	400
2	Red	180	-	550
1	Blue	200	-	650
1/0	Blue	250	-	700
2/0	Yellow	300	-	750
3/0	Red	350	-	825
4/0	Blue	450	-	875

*UL – 486A – Terminals (Copper Conductors Only)

**UL – 486C – Butt Slices and Parallel Slices (Over 6 AWG use 486A values)

***MIL-T-7928 - Military Approved Terminals only as listed

3.2 Crimping Terminals

Specifications and Instructions for crimping are included with the individual Modular Crimp Heads. These documents are called the Application Tooling Specification (ATS) Sheets.

These come with complete Module Crimp Heads. If another copy is needed search on the www.Molex.com for the hand tool order number desired. In the section **Specification & Other Documents** click on the **Application Tooling Specification (PDF) (ATS-EN)**.

Section 4

Preventive Maintenance

- 4.1 Periodic Cleaning
- 4.2 Battery and Battery Charger
- 4.3 Disposal
- 4.4 Warranty

4.1 Periodic Cleaning

Always clean tool after use and keep moving parts clear of dirt and debris.

This tool is basically maintenance free, only the bolt joints at the crimping head have to be oiled regularly.

Before use:

1. Inspect dies for wear or damage such as cracks, gouges, or chips.
2. Inspect the tool for damage or leaks. If damage is detected, return the tool to a Molex representative for inspection.

After use:

1. Wipe all tool surfaces clean with a damp cloth and mild detergent. Excessive dirt and grit can contribute to the premature wear of the tool's internal mechanical parts. If this tool becomes dirty with excessive debris it may jam and become damaged during operation.
2. Fully retract the ram. Place the tool in the carrying case. Store in a cool, dry place.
3. Charge the battery.



WARNING: Do not use compressed air to clean this tool. The forces created by compressed air can force debris into the tool. Failure to observe these precautions may result in injury or property damage.



WARNING: Do not use solvents or flammable liquids to clean the crimping tool. Solvents or flammable liquids could ignite and cause serious injury or property damage.

Monthly:

Thoroughly clean all surfaces.

A routine should be established to keep the tool as free from dirt as possible.

An example of a maintenance chart is shown below. Copy and use this chart to track the maintenance of this crimping tool or use this as a template to create your own schedule or use your company's standard chart, if applicable.

Preventive Maintenance Chart

CHECK SHEET MONTH _____ YEAR _____

Week	Daily Use	Days of the Week							Solution
		MON	TUE	WED	THU	FRI	SAT	SUN	
1									
2									
3									
4									
Cleaning	Daily								After use
Lubrication	(2) bolts in crimping head								Use SAE 10W
Hydraulic oil									

Schedule should be adjusted up or down depending on usage. Molex recommends that a log of preventive maintenance be kept with the tool.

4.2 Battery and Battery Charger



WARNING: Do not dispose of the battery in a fire. It will vent fumes and may explode.
Failure to observe this warning could result in severe injury from harmful fumes or burns from flying debris



CAUTION:

- Do not store the battery at more than 60 °C (140 °F). Damage to the battery can result.
 - Do not use another manufacturer's charger. Other manufacturers' chargers may overcharge and damage the battery.
 - Do not attempt to open the battery. It contains no user-serviceable parts.
- Failure to observe these precautions may result in injury or property damage.



CAUTION:



- Do not allow anything to contact the battery's terminals.
- Do not immerse the battery in liquid. Liquid may create a short circuit and damage the battery.
- If the battery is immersed, contact your service center for proper handling.
- Do not place the battery into a pocket, tool pouch, or tool box with conductive objects.
- Conductive objects may create a short circuit and damage the battery.
- Do not place a battery on moist ground or grass. Moisture may create a short circuit and damage the battery.

Failure to observe these precautions may result in injury or property damage.

The 63816-1000 Crimping Tool is supplied with two batteries and a battery charger. New batteries must be charged before use.

The charging unit is run with a nominal voltage of 115V or 230V (for Europe) and a frequency of 50-60Hz.

Battery Charger indicator lights:

 Constant Glowing	 Flashing Glow	Meaning
Green		Battery is charging. Status of charging < 80 %
	Green (Slowly)	Battery is charging: Status of charging: = 80 %
	Green (Quickly)	Battery is completely charged.
		The battery charger has no power. Please check the connection with the power.
	Yellow	The battery pack is warm
Yellow		The battery pack is too hot. Charging will begin when the temperature of the battery pack drops



CAUTIONS:

1. Charging the battery at low temperatures under 5°C (41°F) is not possible. The battery temperature must be warmed up before starting the battery cycle again.
2. Do not expose the charging unit to rain or snow.
3. Do not charge the battery in or around explosive materials or gases.
4. Do not use any other (dry or car) battery with the charging unit or the crimping tool.
5. Do not use the cord as a handle to carry the battery unit.
6. Do not pull the cord out of a wall socket with force.
7. Do not pull out the plug of the charging unit until after the battery has been charged.
8. Do not insert foreign objects into the charging unit.
9. Do not disassemble the charging unit.
10. Do not place the battery in your pocket or a tool box, if there are conductive materials such as coins, keys, tools or other metallic parts, they may cause injury or property damage.

4.3 Disposal

When this tool is no longer operating properly the different components of this tool will need to be disposed of separately.

1. The battery must be disposed of according to the Rechargeable Battery Recycling Corporation (RBRC) in the USA, or other applicable guidelines in other countries.
2. The remaining parts of this tool must be disposed of according to the domestic environmental standards or the Environmental Protection Agency (EPA) in the USA, or other applicable guidelines in other countries.
3. Because of possible environmental damage, we recommend disposal of the tool by a professional company.



Do not dispose of this tool in your residential or commercial waste, as it would be hazardous to the environment.

4.4 Warranty

All tools are warranted to be free of manufacturing defects for a period of 30 days. Should such a defect occur, we will repair or exchange the tool free of charge. This repair or exchange will not be applicable to altered, misused, or damaged tools. This tool is designed for hand use only. Any clamping, fixturing, or use of handle extensions voids this warranty. After one year Molex recommends the crimping tool be returned to a Molex representative for inspection. Only the heads of the crimping tool are permitted to be changed by the operator.



**Do not damage the seals of this tool.
If seals are damaged the warranty is void.**



CAUTION: Molex crimp specifications are valid only when used with Molex terminals and tooling.

Section 5

Parts List, Assembly Drawings, and Troubleshooting

- 5.1. Parts List and Assembly Drawing
- 5.2. Troubleshooting

5.1 Parts List and Assembly Drawings

Item	Order No	Description	Quantity
1	63816-1000 or 63816-1050	Battery Powered Tool (110 V) or Battery Powered Tool (220 V)	1
2	63816-1002	Battery Unit	2
3	63816-1010 or 63816-1060	Battery Charger (110 V) or (220 V) Not Shown	1





Figure 5-1

Note:

The following Modular Crimp Heads, Adapters and Cutting Head are sold separately and are not included with the 63816-1000 Battery Powered Tool.

The chart below shows applications for the Battery Powered Tool. See Figure 5-2 to 5-5.

Applications for the Battery Powered Tool				
Crimp Head Order No. (Sold separately)		Tool Order no.	Tool Description	
Figure 5-2	DIN style	63816-1100	63816-1000	Battery Powered Crimping Tool 130 kN
Figure 5-3	U-Die	63816-1200		
Figure 5-4	Cutting Tool	63816-1400		

Power Crimp and Cutting Heads (Dies not included with Crimp Heads)	
63816-1100 DIN style Crimp Head	63816-1200 U-Die Crimp Head
 <p>Figure 5-2</p>	 <p>Figure 5-3</p>
63816-1400 Cutting Tool Head	
 <p>Figure 5-4</p>	

5.2 Troubleshooting

 **Make sure the battery is charged before troubleshooting this tool.**

Symptom	Cause	Solution
Tool is inoperative	▪ Dirt, contaminants, etc., in ram area of tool.	Clean the tool.
	▪ Battery unit contacts corroded.	Clean contacts with pencil eraser or contact cleaner.
	▪ Battery unit contacts damaged.	Reform the contacts.
	▪ Tool parts worn or damaged.	Contact a Molex representative.
Dies stop during operation	▪ Battery charge is low.	Charge or replace battery unit.

Visit our Web site at <http://www.molex.com>