

PRODUCT CHANGE NOTIFICATION

#PCN-DC-HEPS-13

Business Unit	Product Line Code	Type of Change	Action	Date of issue
DC	AAA	Mechanical	Notify Distributors and Field	6/20/2013

The following Phoenix Contact products have been modified. Existing specifications will be met or exceeded. Please review and acknowledge this document and inform your personnel as needed.

Description of Change:

The strain relief tab attached to the plug will have a slightly smaller attachment area to aid in the manufacturing process. Research has indicated that the smaller size assists in the adhering the strain relief tab to the connector body without any change to the strain relief tabs functionality. No features of the plug and strain relief tab have been affected by this change. Depending on current stock levels, both versions of the new and old strain relief tabs will be supplied during the conversion phase.

Warranty Information:

N/A

Stock Status

Can existing stock still be used? Y

Is mixture of stock acceptable? N

Transaction Dates:

Date modification goes into effect from Germany: 6/12/2013

Expected first shipment (from Phoenix Contact) of the modified product(s): 1/1/2014

Previous Product

New Product

PRODUCT CHANGE NOTIFICATION

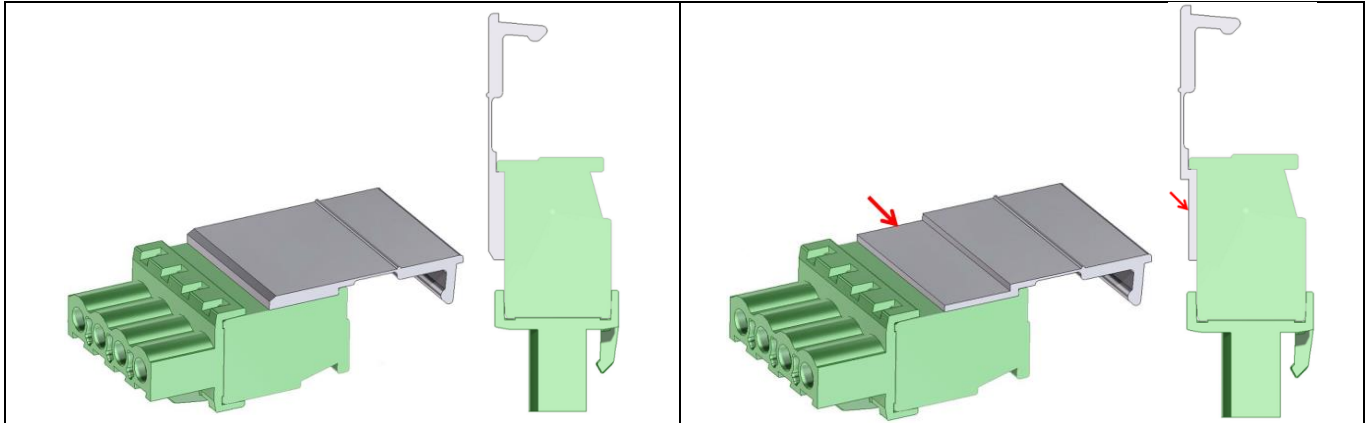

Should you have any issues with the timeline or content of this change, please contact Phoenix Contact using the contact information below. Customers should acknowledge receipt of the PCN within 30 days of delivery of the PCN; provided, however that the failure to acknowledge receipt does not affect the product change or the effective date thereof.

Contact Info:

ANDREW BOGACZYK
(800)888-7388x3075
abogaczyk@phoenixcon.com

Thank you,

James Dunbar, Product Marketing Manager

PRODUCT CHANGE NOTIFICATION

Part#	Type Description
1700130	MVSTBW 2,5/ 3-STEHLUB
1700143	MVSTBW 2,5/ 2-STEHLKMGY LUB
1754047	MVSTBR 2,5/ 3-STEHLBK
1784299	MVSTBW 2,5/ 4-STEHL
5605917	MVSTBW 2,5/ 2-STEHLGY7035LUBBD
1799921	MVSTBR 2,5/ 4-STEHLBK
1804602	MVSTBR 2,5/ 6-STEHLBK
1804615	MVSTBW 2,5/ 3-STEHL OG
1997882	MVSTBR 2,5/ 3-STFEH5,08BKBD+S-
1799918	MVSTBR 2,5/ 2-STEHLBK